

Medical Grade Silicon Capacitor MGSC 0505 47nF BV30



Rev. 2.01

General description

The 47nF Medical Grade Silicon Capacitor targets filtering and decoupling in medical high reliability applications with significant space constraints.

Products have been tested specifically for medical applications and manufacturing is done in our Murata IATF 16949 certified facility.

A final specific electrical test is performed on 100% of our Medical grade capacitors.

47nF MGS Capacitor is using our PICS3-HV process which allows it to operate under 16V at 150°C

Key features

- Temperature stability (up to 150°C)
- Very low profile (100µm)
- Negligible capacitance loss through ageing
- Small size 1.32x1.32mm +/-20µm (0505)
- Low leakage current
- High reliability
- Compatible with high temperature cycling during manufacturing operations (exceeding 300°C)
- Compatible with embedded process. Please refer to the specific Application Note "Embedded Silicon Capacitor"

Key applications

- Any demanding applications, such as industrial medical, implantable medical and healthcare
- Increase battery longevity
- Supply decoupling / filtering of active device



Functional diagram

The next figure provides implementation set-up diagram.

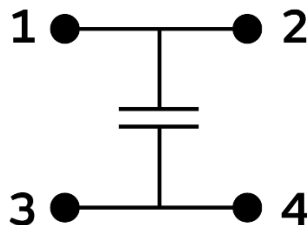

Figure 1 Block Diagram

Electrical performances

Symbol	Parameter	Conditions	Min.	Typ.	Max.	Unit
C	Capacitance value	@25°C	-	47	-	nF
$\Delta C_P^{(1)}$	Capacitance tolerance	@25°C	-15	-	+15	%
T _{OP}	Operating temperature		-55		+150	°C
T _{STG} ⁽²⁾	Storage temperature		10	-	+35	°C
ΔC_T	Capacitance temperature variation	-55°C to 150°C		76		ppm/K
RV _{DC} ⁽³⁾	Rated voltage		-	10	16 ⁽⁴⁾	V _{DC}
ΔC_{RVDC}	Capacitance voltage variation	From 0V to 10V @25°C	-	-	-0.02	%/V _{DC}
IR	Insulation resistor	@25°C, 16V, 120s	-	37	-	GΩ
ESR ⁽⁵⁾	Equivalent Serial Resistor	@+25°C, DC probe measurement LCR meter	-	0.1	-	Ω
ESD	HBM stress ⁽⁶⁾	(100pF/1.5kOhms) max +/-8kV Level H3B	8	-	-	kV

Table 1 - 47nF MGS capacitor performances

⁽¹⁾: other tolerance available upon request

⁽²⁾: without packaging. Please refer to the application note "MIS storage and shelf-life conditions"

⁽³⁾: Lifetime is voltage and temperature dependent, please refer to application note 'Lifetime of 3D capacitors'

⁽⁴⁾: 10 years of intrinsic lifetime prediction at 100°C continuous operation

⁽⁵⁾: Estimate

⁽⁶⁾: please refer to application note 'ESD Challenge in 3D Murata Integrated Passive technology'



Pinning definition

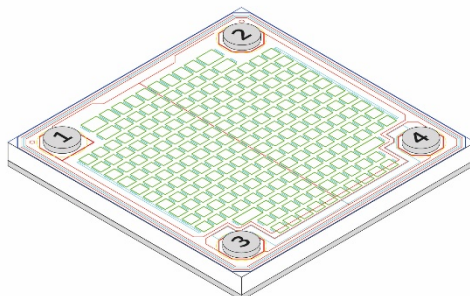

Figure 2 Pinning definition

pin #	Symbol	Coordinates X / Y
1	Signal	-480 / 480
2	Signal	480 / 480
3	Signal	-480 / -480
4	Signal	480 / -480

Table 2 - Pinning description. Reference (0,0) located at the center of the die.

Parts should be glued with non-conductive paste. If conductive glue is used on the backside of the silicon capacitor, it's strongly recommended to avoid connecting the backside to electrical signal. If backside is connected to electrical signal, this signal will absolutely be the same as pads 3-4.

Ordering Information

Regardless of packaging, Murata Integrated Passive Devices delivers products with AQL level II (0.65).

Part number (15NC)	Package		
	Packaging	Finishing	Description
935181732547-T3A	T&R**	Al*	0505 -47nF – BV30 – T&R 1000pcs, Al pads

Table 3 - Packaging and ordering information

(*)AlSiCu
 (**) missing capacitors can reach 0.5%

Pad Metallization

Silicon dies are not sensitive to humidity, please refer to application note 'Products Storage Conditions and Shelf Life'.



Wirebondable component with 2 pads on each terminal.

Pad finishing in Aluminum (3µm thickness), other finishing available on request such as copper, nickel or gold
Metallization = Aluminum

Material regulation

This product is RoHS compliant at the time of publication. For further information about regulation compliancy, please ask your sales representative.

Package outline

This MGS Capacitor is delivered as a naked die, with 150 µm opening for contacts.

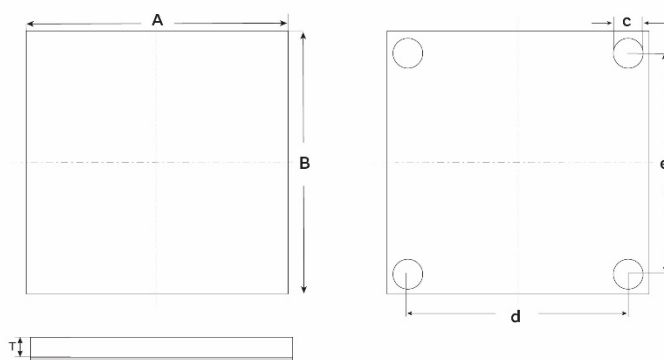

Figure 3 - Package outline drawing

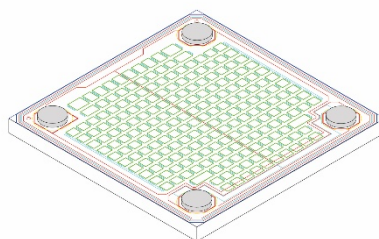

Figure 4 - Package isometric view

A (mm)	B (mm)	T (mm)	c (mm)	d (mm)	e (mm)
1.32 +/- 20µm	1.32 +/- 20µm	0.1 +/- 15µm	0.15	0.96	0.96

Table 4 - Dimensions and tolerances

Assembly

The attachment techniques recommended by Murata on the customer's substrates are fully detailed in specific documents available on our website. To assure the correct use and proper functioning of Murata capacitors **please download the assembly instructions on <https://www.murata.com/en-us/products/capacitor/siliconcapacitors> and read them carefully.**



Figure 5 Scan this QR Code to access the Murata Silicon Capacitor web page

Packaging format

Please refer to application note 'Products Storage Conditions and Shelf Life'.

Tape and Reel:

Dies are flipped in the tape cavity (bump down) with die ID located near the driving holes of the tape.

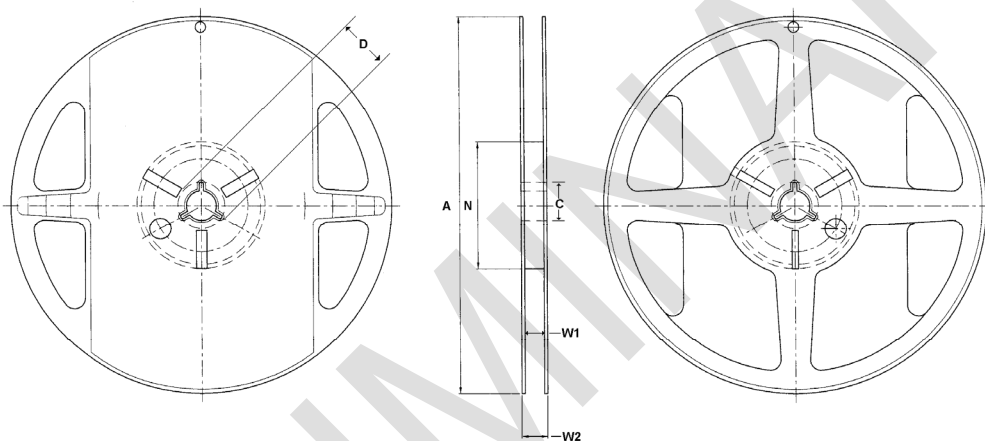

Figure 5 - Reel drawing

Tape Width	Diameter A	C	D	Hub N	W1	W2
8	178 (7 inches)	13.5	20.2	60	9	11.5

Table 5 – Reel dimensions (mm)

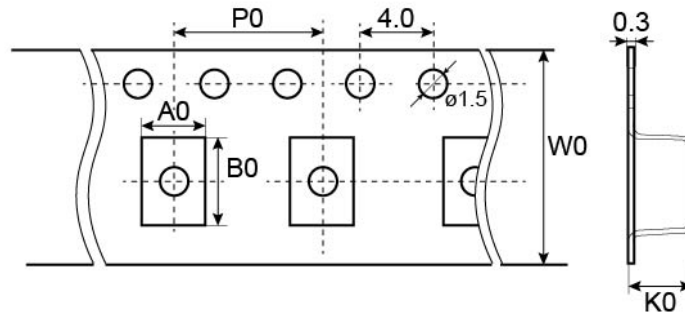

Figure 6 - Tape drawing

Cavity dimensions			Carrier tape width W0	Carrier tape pitch P0	Quantity per reel
Ao	Bo	Ko			
1.48	1.58	0.31	8	4	1000

Table 6 - Tape dimensions (mm)



Definitions

Data sheet status

Objective specification: This data sheet contains target or goal specifications for product development.

Preliminary specification: This data sheet contains preliminary data; supplementary data may be published later.

Product specification: This data sheet contains final product specifications.

Limiting values

Stress above one or more of the limiting values may cause permanent damage to the device. These are stress ratings only and operation of the device at these or any other conditions above those given in the Electrical performances sections of this specification is not implied. Exposure to limiting values for extended periods may affect device reliability.

Application information

Where application information is given, it is advisory and does not form part of the specification.

Revision history

Revision	Date	Description	Author
0.1	6/07/2020	Objective specifications	S. Leruez
2.01	24/11/2020	Template update – Status update	C. Guezennec

Disclaimer / Life support applications

These products are not designed for use in life support appliances, devices, or systems where malfunction of these products can reasonably be expected to result in personal injury. Murata customers using or selling these products for use in such applications do so at their own risk and agree to fully indemnify Murata for any damages resulting from such improper use or sale.

Reproduction in whole or in part is prohibited without the prior written consent of the copyright owner. The information presented in this document does not form part of any quotation or contract, is believed to be accurate and reliable and may be changed without notice. No liability will be accepted by the publisher for any consequence of its use. Publication thereof does not convey nor imply any license under patent or other industrial or intellectual property rights.

Murata Integrated Passive Solutions S.A. makes no representation that the use of its products in the circuits described herein, or the use of other technical information contained herein, will not infringe upon existing or future patent rights. The descriptions contained herein do not imply the granting of licenses to make, use, or sell equipment constructed in accordance therewith. Specifications are subject to change without notice.



www.murata.com

mis@murata.com