

# DATA SHEET

**CURRENT SENSOR - LOW TCR**

AUTOMOTIVE GRADE

PA series

5%, 1%, 0.5%

sizes 0100/0201/0402/0603/0805/1206/2010

RoHS compliant & Halogen free



**SCOPE**

This specification describes PA0100 to 2010 series current sensor - low TCR with metal substrate.

**APPLICATIONS**

- Smart Phone
- Batteries
- Computer
- Telecom / Datacom
- Industrial / Power supply
- Car electronics

**FEATURES**

- AEC-Q200 qualified
- Halogen-free Epoxy
- Total lead free without RoHS exemption
- RoHS compliant
- Reduce environmentally hazardous wastes
- High component and equipment reliability
- Non-forbidden materials used in products/production
- Low resistances applied to current sensing
- Moisture sensitivity level: MSL 1

**ORDERING INFORMATION - GLOBAL PART NUMBER**

Global part numbers are identified by the series, size, tolerance, packing type, temperature coefficient, taping reel and resistance value.

**GLOBAL PART NUMBER**

**PA XXXX X X X XX XXXX X**  
 (1) (2) (3) (4) (5) (6) (7)

**(1) SIZE**

0100/0201/0402/0603/0805/1206/2010

**(2) TOLERANCE**

D = ±0.5%  
 F = ±1%  
 J = ±5%

**(3) PACKAGING TYPE**

R = Paper taping reel (PA0100~PA1206)  
 K = Embossed taping reel (PA2010)

**(4) TEMPERATURE COEFFICIENT OF RESISTANCE**

E = ± 50ppm/°C  
 M = ± 75ppm/°C  
 F = ± 100ppm/°C  
 L = ± 150ppm/°C  
 G = ± 200ppm/°C  
 I = ± 300ppm/°C

**(5) TAPING REEL**

07 / 7W / 7T / 47 / 57 / 87 inch dia. Reel and specific rated power  
 Detailed power rating are shown in the Table 2.

**(6) RESISTANCE VALUE**

1 mΩ to 20 mΩ

**(7) DEFAULT CODE**

Letter L / Z is the system default code for ordering only. <sup>(Note)</sup>  
 L is for 0100/0201/0402/0603/0805  
 Z is for only 1206/2010

Resistance rule of global part number	
Resistance code rule	Example
0RXXX	0R001 = 1 mΩ
(1 to 20 mΩ)	0R02 = 20 mΩ

**ORDERING EXAMPLE**

The ordering code for a PA0805  
 0.125W chip resistor,TC50 value 0.01Ω  
 (10mR) with ±1% tolerance, supplied in  
 7-inch tape reel with 5Kpcs quantify is:  
**PA0805FRE070R01L.**

**NOTE**

1. All our RChip products are RoHS compliant. "LFP" of the internal 2D reel label mentions "Lead-Free Process"

**MARKING**

PA0100/0201/0402/0603/0805/1206/2010



**CONSTRUCTION**

The resistors are constructed using outstanding TCR level materials, which make Yageo PA resistors excellent for current sensing application in battery charger circuit & DC-DC converter.

The advanced resistive materials are adopted to get the precisely required resistance.

Finally, the three materials of external terminations (Cu / Ni / matte Tin) are added, as shown in Fig. 2.

**Outlines**

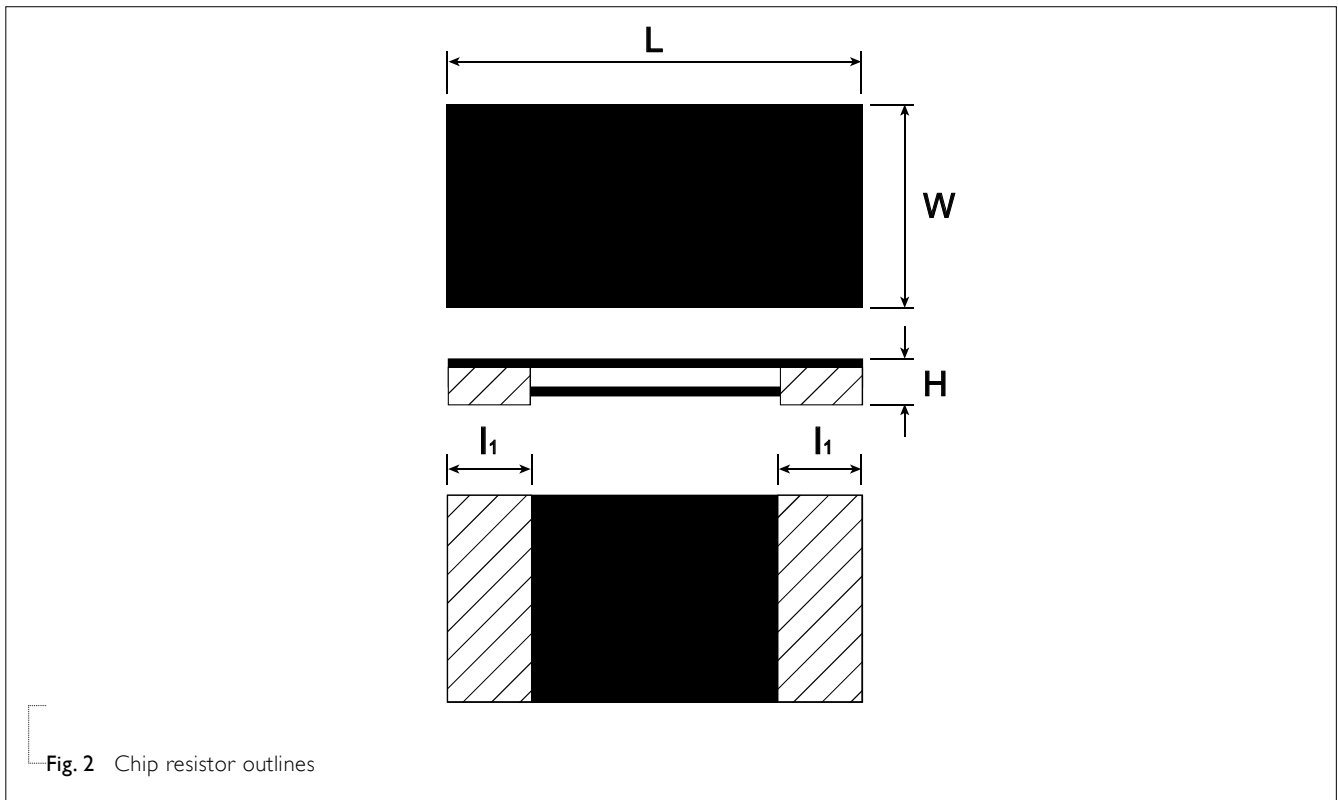

Fig. 2 Chip resistor outlines

## DIMENSION

Table 1 For outlines, please refer to Fig. 2

TYPE	RESISTANCE RANGE	L (mm)	W (mm)	H (mm)	ll (mm)
PA0100	$10\text{m}\Omega \leq R \leq 20\text{m}\Omega$	$0.40 \pm 0.03$	$0.20 \pm 0.03$	Max. 0.15	$0.10 \pm 0.03$
PA0201	$5\text{m}\Omega \leq R \leq 20\text{m}\Omega$	$0.60 \pm 0.03$	$0.31 \pm 0.04$	Max. 0.30	$0.15 \pm 0.06$
PA0402	$2\text{m}\Omega \leq R \leq 20\text{m}\Omega$	$1.00 \pm 0.10$	$0.55 \pm 0.10$	Max. 0.40	$0.25 \pm 0.10$
PA0603	1 m $\Omega$	$1.60 \pm 0.20$	$0.80 \pm 0.20$	$0.55 \pm 0.15$	$0.38 \pm 0.12$
	2m $\Omega$	$1.60 \pm 0.20$	$0.80 \pm 0.20$	$0.45 \pm 0.15$	$0.38 \pm 0.12$
	$2.5\text{m}\Omega \leq R \leq 20\text{m}\Omega$	$1.60 \pm 0.20$	$0.80 \pm 0.20$	$0.30 \pm 0.15$	$0.38 \pm 0.12$
PA0805	1m $\Omega$	$2.03 \pm 0.20$	$1.27 \pm 0.20$	$0.55 \pm 0.15$	$0.60 \pm 0.15$
	1.5/ 2m $\Omega$	$2.03 \pm 0.20$	$1.27 \pm 0.20$	$0.45 \pm 0.15$	$0.50 \pm 0.15$
	$2.5\text{m}\Omega \leq R \leq 20\text{m}\Omega$	$2.03 \pm 0.20$	$1.27 \pm 0.20$	$0.30 \pm 0.15$	$0.35 \pm 0.20$
PA1206	1m $\Omega$	$3.20 \pm 0.25$	$1.60 \pm 0.25$	$0.65 \pm 0.25$	$0.51 \pm 0.25$
	2m $\Omega$	$3.20 \pm 0.25$	$1.60 \pm 0.25$	$0.55 \pm 0.25$	$0.60 \pm 0.25$
	2.5/ 3m $\Omega$	$3.20 \pm 0.25$	$1.60 \pm 0.25$	$0.40 \pm 0.25$	$0.80 \pm 0.30$
	$4\text{m}\Omega \leq R \leq 20\text{m}\Omega$	$3.20 \pm 0.25$	$1.60 \pm 0.25$	$0.40 \pm 0.25$	$0.60 \pm 0.30$
PA2010	$1\text{m}\Omega \leq R \leq 3\text{m}\Omega$	$5.08 \pm 0.25$	$2.54 \pm 0.25$	$0.50 \pm 0.25$	$1.40 \pm 0.25$
	$4\text{m}\Omega \leq R \leq 20\text{m}\Omega$	$5.08 \pm 0.25$	$2.54 \pm 0.25$	$0.40 \pm 0.25$	$0.70 \pm 0.25$

## Note:

- For relevant physical dimensions, please refer to construction outlines.
- Please contact with sales offices, distributors and representatives in your region before ordering.

## ELECTRICAL CHARACTERISTICS

Table 2 POWER RATING<sup>(4)</sup> @ 70°C

SIZE	POWER RATING <sup>(4)</sup> @ 70°C						TOLERANCE <sup>(2)</sup>	RESISTANCE RANGE	TEMPERATURE COEFFICIENT OF RESISTANCE <sup>(3)</sup>	
	07	7W	7T	47	57	87				
0100	1/32W	1/16W	--	--	--	--	$\pm 1\%(F)$ $\pm 5\%(J)$	$10\text{m}\Omega \leq R \leq 20\text{m}\Omega$	$\pm 300 \text{ ppm}/^\circ\text{C}(I)$	
0201	1/20W	1/10W	3/20W	1/4W	--	--	$\pm 0.5\%(D)$	20m $\Omega$	$\pm 150 \text{ ppm}/^\circ\text{C}(L)$	
							$\pm 1\%(F)$ $\pm 5\%(J)$	$5\text{m}\Omega \leq R \leq 20\text{m}\Omega$		
0402	1/16W	1/8W	1/6W	1/4W	1/3W	--	$\pm 0.5\%(D)$	$15\text{m}\Omega \leq R \leq 20\text{m}\Omega$	$\pm 150 \text{ ppm}/^\circ\text{C}(L)$	
							$\pm 1\%(F)$ $\pm 5\%(J)$	$2\text{m}\Omega \leq R \leq 20\text{m}\Omega$		
0603	1/10W	1/5W	1/3W	2/5W	1/2W	--	$\pm 0.5\%(D)$	$10\text{m}\Omega \leq R \leq 20\text{m}\Omega$	1m $\Omega$	
							$\pm 1\%(F)$ $\pm 5\%(J)$	$1\text{m}\Omega \leq R \leq 20\text{m}\Omega$	2/2.5m $\Omega$	$\pm 200 \text{ ppm}/^\circ\text{C}(G)$ $\pm 150 \text{ ppm}/^\circ\text{C}(L)$
								$3\text{m}\Omega \leq R \leq 20\text{m}\Omega$	$\pm 50 \text{ ppm}/^\circ\text{C}(E), \pm 75 \text{ ppm}/^\circ\text{C}(M)$	
0805	1/8W	1/4W	--	1/2W	--	1W	$\pm 0.5\%(D)$	$10\text{m}\Omega \leq R \leq 20\text{m}\Omega$	1/1.5m $\Omega$	
							$\pm 1\%(F)$ $\pm 5\%(J)$	$1\text{m}\Omega \leq R \leq 20\text{m}\Omega$	$2\text{m}\Omega \leq R \leq 20\text{m}\Omega$	$\pm 150 \text{ ppm}/^\circ\text{C}(L)$ $\pm 50 \text{ ppm}/^\circ\text{C}(E)$
1206	1/4W	1/2W	--	1W	--	--	$\pm 0.5\%(D)$	$5\text{m}\Omega \leq R \leq 20\text{m}\Omega$	1/2m $\Omega$	
							$\pm 1\%(F)$ $\pm 5\%(J)$	$1\text{m}\Omega \leq R \leq 20\text{m}\Omega$	$3\text{m}\Omega \leq R \leq 20\text{m}\Omega$	$\pm 100 \text{ ppm}/^\circ\text{C}(F)$ $\pm 50 \text{ ppm}/^\circ\text{C}(E)$
2010	1/2W	1W	3/2W	2W	--	--	$\pm 0.5\%(D)$	$5\text{m}\Omega \leq R \leq 20\text{m}\Omega$ (2W : $5\text{m}\Omega \leq R \leq 10\text{m}\Omega$ )	$\pm 50 \text{ ppm}/^\circ\text{C}(E)$	
							$\pm 1\%(F)$ $\pm 5\%(J)$	$1\text{m}\Omega \leq R \leq 20\text{m}\Omega$		
								$1\text{m}\Omega \leq R \leq 10\text{m}\Omega$ (2W : $1\text{m}\Omega \leq R \leq 10\text{m}\Omega$ )		

Note: 1. Please contact with sales offices, distributors and representatives in your region before ordering.

- Global part number (code7)
- Global part number (code9)
- Global part number (code10-11)

**FUNCTIONAL DESCRIPTION**

**OPERATING TEMPERATURE RANGE**

PA0100 to PA0402 Range: -55°C to +125°C

PA0603/ 0805 Range: -55°C to +155°C

PA1206/ 2010 Range: -55°C to +170°C

**POWER RATING**

Standard rated power at 70°C: For detail power value, please refer to Table 2.

**RATED VOLTAGE**

The DC or AC (rms) continuous working voltage corresponding to the rated power is determined by the following formula:

$$V = \sqrt{(P \times R)}$$

Where

V = Continuous rated DC or AC (rms) working voltage (V)

P = Rated power (W)

R = Resistance value ( $\Omega$ )

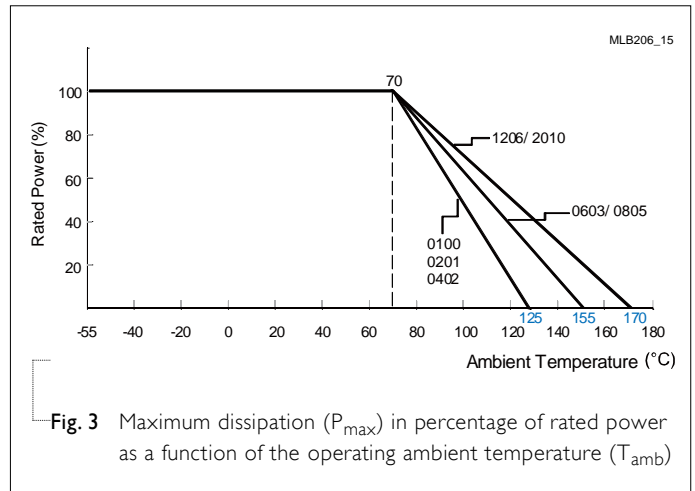

**PACKING STYLE AND PACKAGING QUANTITY**

Table 3 Packing style and packaging quantity

PACKING STYLE	REEL DIMENSION	PA0100	PA0201	PA0402	PA0603	PA0805	PA1206	PA2010
Paper Taping Reel (R)	7" (178 mm)	20,000	10,000	10,000	5,000	5,000	4,000	-
Embossed Taping Reel (K)	7" (178 mm)	-	-	-	-	-	-	4,000

**PAPER TAPE**

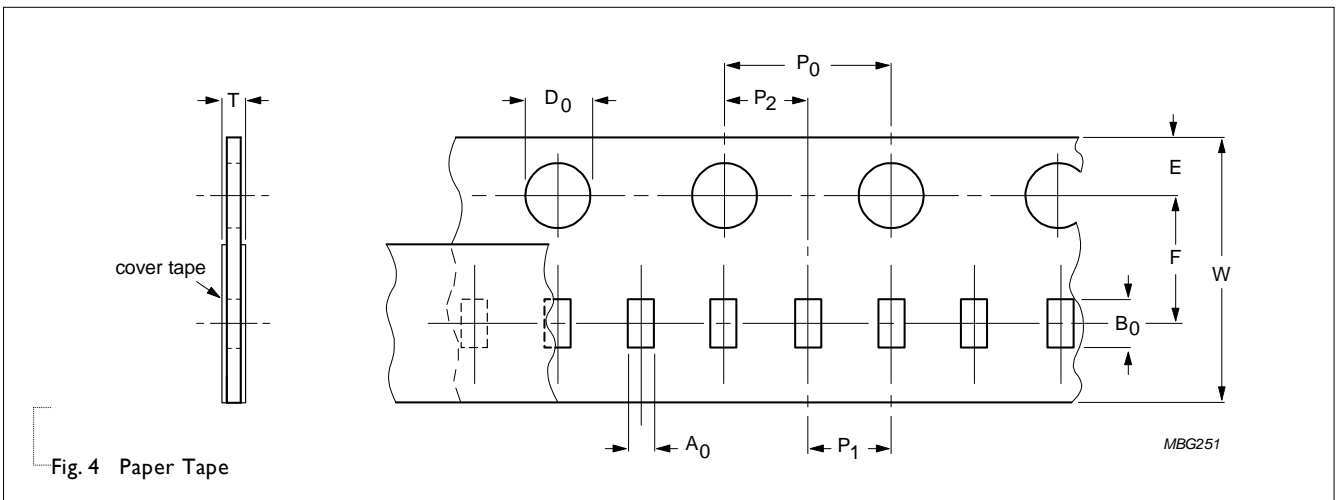

**EMBOSSED TAPE**

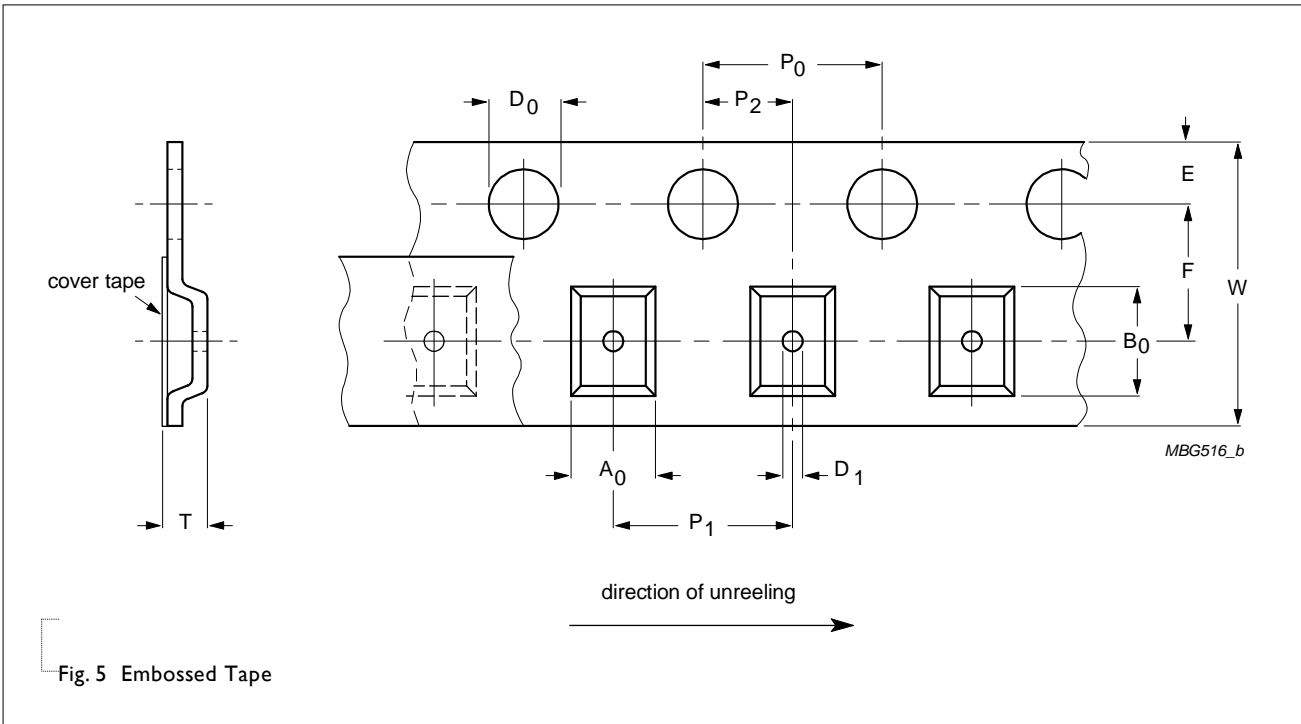

Fig. 5 Embossed Tape

Table 4 Dimensions of paper tape for relevant chip resistors size

SIZE	SYMBOL										Unit: mm
	A <sub>0</sub>	B <sub>0</sub>	W	E	F	P <sub>0</sub>	P <sub>1</sub>	P <sub>2</sub>	ΦD <sub>0</sub>	T	
PA0100	0.24±0.03	0.45±0.03	8.00±0.20	1.75±0.10	3.50±0.05	4.00±0.05	2.00±0.10	2.00±0.05	1.50±0.10	0.31±0.10	
PA0201	0.39±0.10	0.70±0.10	8.00±0.30	1.75±0.10	3.50±0.10	4.00±0.10	2.00±0.10	2.00±0.10	1.55±0.05	0.43±0.10	
PA0402	0.59±0.10	1.10±0.10	8.00±0.30	1.75±0.10	3.50±0.10	4.00±0.10	2.00±0.10	2.00±0.10	1.55±0.05	0.53±0.10	
PA0603	1.08±0.10	1.90±0.10	8.00±0.30	1.75±0.10	3.50±0.10	4.00±0.10	4.00±0.10	2.00±0.10	1.55±0.05	0.60±0.10	
PA0805	1.60±0.10	2.35±0.10	8.00±0.30	1.75±0.10	3.50±0.10	4.00±0.10	4.00±0.10	2.00±0.10	1.55±0.05	0.60±0.10 <sup>(1)</sup>	
	1.60±0.10	2.35±0.10	8.00±0.30	1.75±0.10	3.50±0.10	4.00±0.10	4.00±0.10	2.00±0.10	1.55±0.05	0.53±0.10 <sup>(2)</sup>	
PA1206	1.90±0.10	3.50±0.10	8.00±0.30	1.75±0.10	3.50±0.10	4.00±0.10	4.00±0.10	2.00±0.10	1.55±0.05	0.85±0.15	

Note: 1.  $1\text{m}\Omega \leq R \leq 2\text{m}\Omega$  ( $T = 0.60 \pm 0.10\text{mm}$ )  
 2.  $2.5\text{m}\Omega \leq R \leq 20\text{m}\Omega$  ( $T = 0.53 \pm 0.10\text{mm}$ )

Table 5 Dimensions of embossed tape for relevant chip resistors size

SIZE	SYMBOL										Unit: mm
	A <sub>0</sub>	B <sub>0</sub>	W	E	F	P <sub>0</sub>	P <sub>1</sub>	P <sub>2</sub>	ΦD <sub>0</sub>	T	
PA2010	3.40±0.15	6.70±0.15	12.0±0.30	1.75±0.10	5.50±0.10	4.00±0.10	4.00±0.10	2.00±0.10	1.55±0.10	0.85±0.15	

**REEL SPECIFICATION**

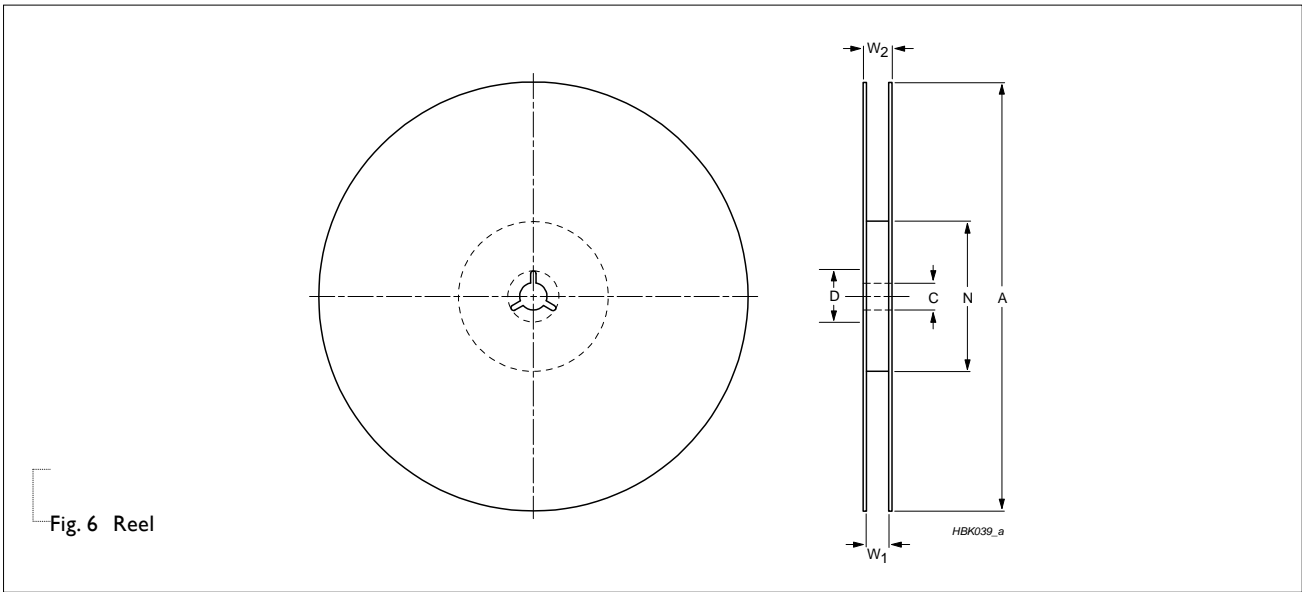

**Table 6** Dimensions of reel specification for relevant chip resistors size

SIZE	QUANTITY PER REEL	REEL SIZE		SYMBOL				
		8mm TAPE WIDE	12mm TAPE WIDE	A	N	C	D	W <sub>1</sub>
PA0100	20,000	7" (Φ178mm)	-	180.0+0/-3.0	60.0+1/-0	13.00±0.2	21.0±0.8	9.0±0.3
PA0201	10,000	7" (Φ178mm)	-	178.0±1.0	60.0+1/-0	13.50±0.5	21.0±0.8	9.0±0.5
PA0402	10,000	7" (Φ178mm)	-	178.0±1.0	60.0+1/-0	13.50±0.5	21.0±0.8	9.0±0.5
PA0603	5,000	7" (Φ178mm)	-	178.0±1.0	60.0+1/-0	13.50±0.5	21.0±0.8	9.0±0.5
PA0805	5,000	7" (Φ178mm)	-	178.0±1.0	60.0+1/-0	13.50±0.5	21.0±0.8	9.0±0.5
PA1206	4,000	7" (Φ178mm)	-	178.0±1.0	60.0+1/-0	13.50±0.5	21.0±0.8	9.0±0.5
PA2010	4,000	-	7" (Φ178mm)	178.0±1.0	60.0+1/-0	13.50±0.5	21.0±0.8	13.6±0.5

**LEADER/TRAILER TAPE SPECIFICATION**

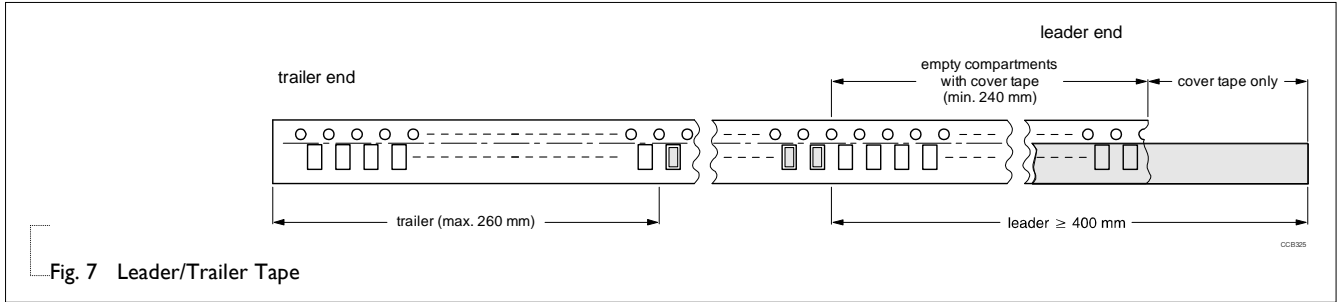

Fig. 7 Leader/Trailer Tape

**FOOTPRINT AND SOLDERING PROFILES**

For recommended soldering profiles, please refer to data sheet “Chip resistors mounting”.

**FOOTPRINT**

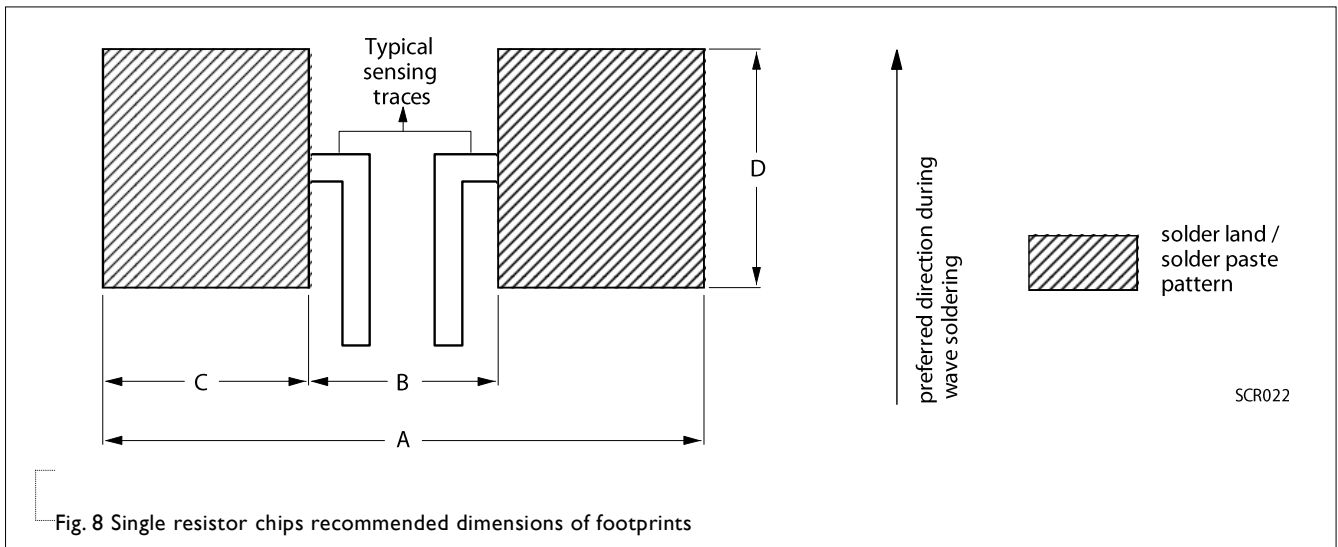

Fig. 8 Single resistor chips recommended dimensions of footprints

Table 7 Footprint dimensions

TYPE	RESISTANCE RANGE	A	B	C	D	Unit: mm
PA0100	$10m\Omega \leq R \leq 20m\Omega$	0.5~0.8	0.16~0.2	0.17~0.3	0.2~0.4	
PA0201	$5m\Omega \leq R \leq 20m\Omega$	1.00	0.30	0.35	0.40	
PA0402	$2m\Omega \leq R \leq 20m\Omega$	2.00	0.40	0.80	0.60	
PA0603	$1m\Omega$	2.20	0.50	0.70	0.90	
	$1m\Omega < R \leq 20m\Omega$	2.20	0.80	0.70	0.90	
PA0805	$1m\Omega$	4.10	0.50	1.80	1.44	
	$1.5m\Omega \leq R \leq 20m\Omega$	4.60	1.00	1.80	1.44	
PA1206	$1m\Omega / 2m\Omega$	4.20	1.00	1.60	1.84	
	$2.5m\Omega / 3m\Omega$	4.80	1.00	1.90	1.84	
	$4m\Omega \leq R \leq 20m\Omega$	4.80	1.20	1.80	1.84	
PA2010	$1m\Omega \leq R \leq 3m\Omega$	6.00	1.40	2.30	3.00	
	$4m\Omega \leq R \leq 20m\Omega$	6.00	3.50	1.25	3.00	



## TESTS AND REQUIREMENTS

Table 8 Test condition, procedure and requirements

TEST	TEST METHOD	PROCEDURE	REQUIREMENT
Short time overload	IEC60115-1 4.13	5 times of rated power for 5 seconds at room temperature	0100 : $\pm(2.0\%+0.0005\Omega)$ Others : $\pm(1.0\%+0.0005\Omega)$ No visible damage
High Temperature Exposure/ Endurance at Upper Category Temperature	MIL-STD-202G-Method 108	1,000 hours at maximum operating temperature depending on specification, unpowered No direct impingement of forced air to the parts Tolerances: 0100/0201/0402: $125\pm 3^{\circ}\text{C}$ 0603/0805: $155\pm 3^{\circ}\text{C}$ 1206/2010: $170\pm 3^{\circ}\text{C}$	0100 : $\pm(3.0\%+0.0005\Omega)$ Others : $\pm(1.0\%+0.0005\Omega)$
Temperature Cycling	JESD22-A104	1,000 cycles, $-55/+125^{\circ}\text{C}$ for 1 cycle per hour	$\pm(1.0\%+0.0005\Omega)$
Moisture Resistance	MIL-STD-202G-Method 106	Each temperature / humidity cycle is defined at 8 hours (method 106F), 3 cycles / 24 hours for 10d with $25^{\circ}\text{C} / 65^{\circ}\text{C}$ 95% R.H, without steps 7a & 7b, unpowered	0100 : $\pm(3.0\%+0.0005\Omega)$ Others : $\pm(0.5\%+0.0005\Omega)$
Biased Humidity	MIL-STD-202 Method 103	1,000 hours; $85^{\circ}\text{C} / 85\%$ RH 10% of operating power	0100 : $\pm(3.0\%+0.0005\Omega)$ Others : $\pm(1.0\%+0.0005\Omega)$
Operational Life/ Endurance	MIL-STD-202G-Method 108 IEC 60115-1 4.25.1	1,000 hours at $125\pm 3^{\circ}\text{C}$ , de-rated power applied for 1.5 hours on, 0.5 hour off, still-air required 1,000 hours at $70\pm 2^{\circ}\text{C}$ applied rated power 1.5 hours on, 0.5 hour off, still air required	0100 : $\pm(3.0\%+0.0005\Omega)$ others $\pm(1.0\%+0.0005\Omega)$
Resistance to Solvents	MIL-STD-202 Method 215	Immerse in isopropyl alcohol for 5 min with ultrasonic at room temperature	No visible damage
Mechanical Shock	MIL-STD-202 Method 213	Three shocks in each direction shall be applied along the three mutually perpendicular axes of the test specimen. Peak value: 100 g's Duration: 6 ms Velocity change: 12.3 ft/s Waveform: Half sine	0100 : $\pm(1.0\%+0.0005\Omega)$ Others : $\pm(0.5\%+0.0005\Omega)$
Vibration	MIL-STD-202 Method 204	5 g's for 20 min., 12 cycles each of 3 orientations Test from 10-2000 Hz.	0100 : $\pm(1.0\%+0.0005\Omega)$ Others : $\pm(0.5\%+0.0005\Omega)$
Resistance to Soldering Heat	MIL-STD-202G-method 210	Condition B, no pre-heat of samples Leadfree solder, $260^{\circ}\text{C}$ , 10 seconds immersion time Procedure 2 for SMD: devices fluxed and cleaned with isopropanol	0100 : $\pm(1.0\%+0.0005\Omega)$ Others : $\pm(0.5\%+0.0005\Omega)$ No visible damage

TEST	TEST METHOD	PROCEDURE	REQUIREMENT
Thermal Shock	MIL-STD-202 Method 107	-55/+125°C, Number of cycles is 300. Maximum transfer time is 20 seconds. Dwell time is 15 minutes. Air -Air	±(1.0%+0.0005Ω) No visible damage
Electrostatic Discharge	AEC-Q200-002	Human Body Model, 1 pos + 1 neg. 0805/ 1206/ 2010 : 2KV 0402/ 0603 : 1KV 0100/ 0201: 500V	±(1.0%+0.0005Ω) No visible damage
Solderability - Wetting	J-STD-002	0201 to 2010 : (a) Method B, aging 4 hours at 155°C dry heat, dipping at 235±3°C for 5±0.5 seconds. (b) Method B, steam aging 8 hours, dipping at 215±3°C for 5±0.5 seconds. (c) Method D, steam aging 8 hours, dipping at 260±3 °C for 30±0.5 seconds.  0100 : 1st step: Method B, aging 4 hours at 155°C dry heat. 2nd step: Lead-free solder bath at 245±3°C, dipping at 245±3°C for 3±0.5 seconds	Well tinned (>95% covered) No visible damage
Flammability	UL94	Try to inflame a specimen by a needle flame	No ignition of specimen;V-0
Board Flex / Bending	AEC-Q200-005	Chips mounted on a 90mm glass epoxy resin PCB (FR4), Bending for 0100: 5mm 0201: 3mm 0402 and above: 2mm Holding time: Min.60 seconds	±(1.0%+0.0005Ω)
Terminal Strength (SMD)	AEC-Q200-006	Applied 0100: 0.98N 0201: 3N 0402: 5N 0603/ 0805/ 1206/ 2010: 17.7N for 60±1 seconds.	±(1.0%+0.0005Ω) No visible damage
Flame Retardance	AEC-Q200-001	Apply voltage to increase the surface temp to 350°C	No flame, no explosion
Temperature Coefficient of Resistance (T.C.R.)	IEC 60115-1 4.8	At +25/+125°C Formula: $T.C.R = \frac{R_2 - R_1}{R_1(t_2 - t_1)} \times 10^6 \text{ (ppm/°C)}$ Where t1 =+25°C or specified room temperature t2 =+125°C test temperature R1 =resistance at reference temperature in ohms R2=resistance at test temperature in ohms	Refer to table 2

REVISION HISTORY

REVISION	DATE	CHANGE NOTIFICATION	DESCRIPTION
Version 1	Jun. 10, 2021	-	- Add size of PA0100 and tol. $\pm 0.5\%$ for 0201/0402/0603/2010
Version 0	May 07, 2020	-	- New datasheet for automotive grade current sensor – PA0201/0402/0603/0805/1206/2010 series.