

# DATA SHEET

## GAS DISCHARGE TUBES TELEPHONE INTERFACE

3R-8 series

RoHS compliant & free



Product specification— March 16, 2021 V.1



## Gas Discharge Tube (GDT) Data Sheet

### Features

- Provide ultra-fast response to surge voltage from slow-rising surge of 100V/s to rapid-rising surge of 1KV/μs
- Stable breakdown voltage
- High insulation resistance
- Low capacitance (≤2pF)
- High holdover voltage
- Large absorbing transient current capability
- Micro-Gap Design
- Size: 8.0mm\*10.0mm
- Storage and operating temperature: -40°C ~ +85°C
- Meets MSL level 1, per J-STD-020
- Safety certification: UL



### Applications

- Repeaters, Modems
- Telephone Interface, Line cards
- Data communication equipment
- Line test equipment

### Part Number Code

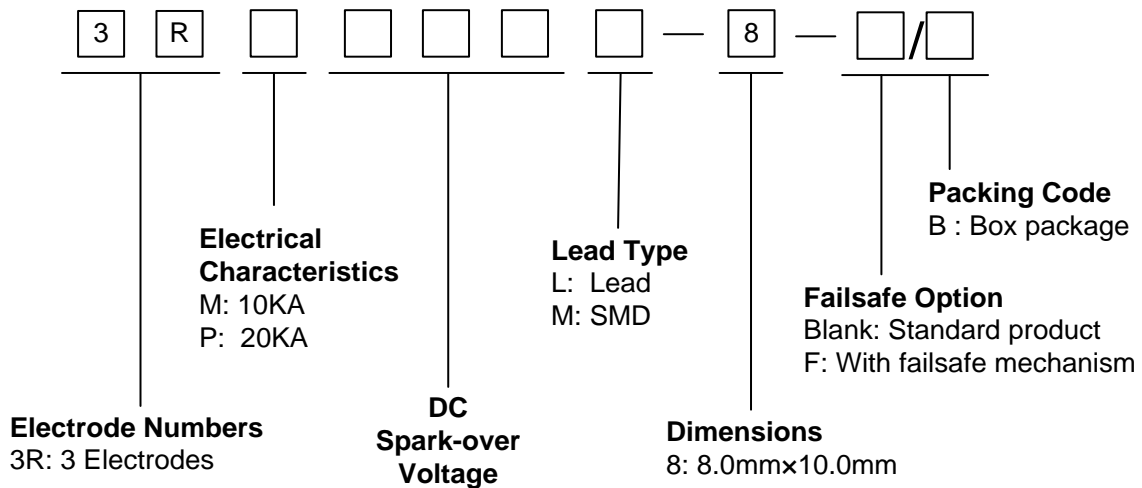

### Ordering Code for different package in 3RMxxxL-8 and 3RPxxxL-8 series

Box package: Add suffix “/B” at the end of the part number, such as 3RM075L-8/B or 3RP075L-8/B

### Marking

- B** : BrightKing Logo
- 3RM090-8 : Device Marking Code
- XXXX : Internal Control Code

**Dimensions**

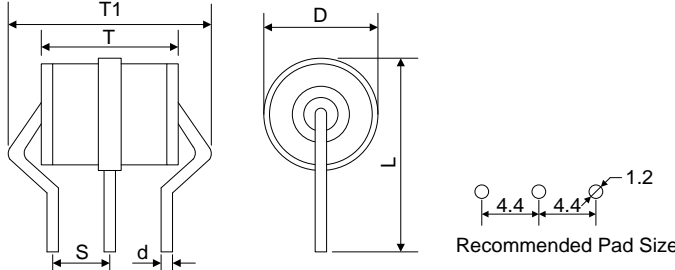
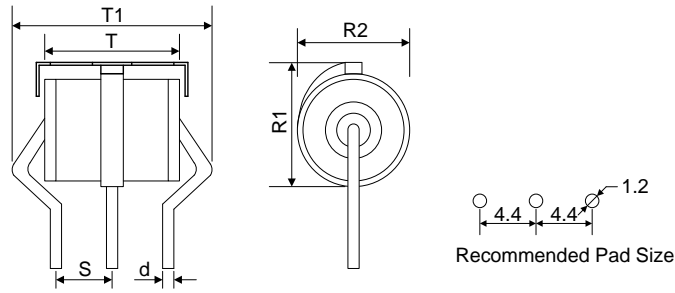
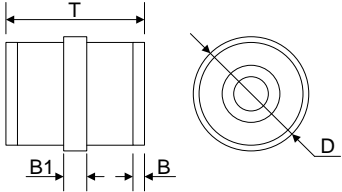
L Type		Symbol	Dimension (mm)	
			Spec.	Tolerance
		D	8.0	+0.2, -0.8
		T	10.0	±0.5
		T1	12.0	±0.5
		L	15.0	±0.5
L-F Type		S	4.4	±0.4
		d	1.0	±0.1
		R1	9.8	±0.4
		R2	8.1	±0.3
M Type		D	8.0	+0.2, -0.8
		T	10.0	±0.5
		B	0.5	±0.1
		B1	1.5	±0.2
		Notes: This type is not suitable for PCB soldering.		

**Electrical Characteristics**

Part Number		DC Spark-over Voltage	Maximum Impulse Spark-over Voltage	Nominal Impulse Discharge Current	Alternating Discharge Current	Impulse Life	Minimum Insulation Resistance		Maximum Capacitance	Device Marking Code
		100V/s	1000V/μs	8/20μs 10times	50Hz, 1sec	10/1000μs 100A	Test Voltage	(GΩ)	1MHz	
		(V)	(V)	(KA)	(A)	(times)	DC(V)		(pF)	
3RM075L-8	3RM075M-8	75±20%	700	10	10	300	25	1.0	2.0	3RM075-8
3RM090L-8	3RM090M-8	90±20%	700	10	10	300	50	1.0	2.0	3RM090-8
3RM150L-8	3RM150M-8	150±20%	700	10	10	300	100	1.0	2.0	3RM150-8
3RM200L-8	3RM200M-8	200±20%	700	10	10	300	100	1.0	2.0	3RM200-8
3RM230L-8	3RM230M-8	230±20%	700	10	10	300	100	1.0	2.0	3RM230-8
3RM350L-8	3RM350M-8	350±20%	850	10	10	300	100	1.0	2.0	3RM350-8
3RM400L-8	3RM400M-8	400±20%	850	10	10	300	100	1.0	2.0	3RM400-8
3RM470L-8	3RM470M-8	470±20%	950	10	10	300	250	1.0	2.0	3RM470-8
3RM600L-8	3RM600M-8	600±20%	1300	10	10	300	250	1.0	2.0	3RM600-8

**Electrical Characteristics**

Part Number		DC Spark-over Voltage	Maximum Impulse Spark-over Voltage	Nominal Impulse Discharge Current	Alternating Discharge Current	Impulse Life	Minimum Insulation Resistance		Maximum Capacitance	Device Marking Code
		100V/s	1000V/ $\mu$ s	8/20 $\mu$ s 10times	50Hz,1sec	10/1000 $\mu$ s 100A	Test Voltage	(G $\Omega$ )	1MHz	
		(V)	(V)	(KA)	(A)	(times)	DC(V)		(pF)	
3RP075L-8	3RP075M-8	75 $\pm$ 20%	700	20	20	300	25	1.0	2.0	3RP075-8
3RP090L-8	3RP090M-8	90 $\pm$ 20%	700	20	20	300	50	1.0	2.0	3RP090-8
3RP150L-8	3RP150M-8	150 $\pm$ 20%	700	20	20	300	100	1.0	2.0	3RP150-8
3RP200L-8	3RP200M-8	200 $\pm$ 20%	700	20	20	300	100	1.0	2.0	3RP200-8
3RP230L-8	3RP230M-8	230 $\pm$ 20%	700	20	20	300	100	1.0	2.0	3RP230-8
3RP350L-8	3RP350M-8	350 $\pm$ 20%	850	20	20	300	100	1.0	2.0	3RP350-8
3RP400L-8	3RP400M-8	400 $\pm$ 20%	850	20	20	300	100	1.0	2.0	3RP400-8
3RP470L-8	3RP470M-8	470 $\pm$ 20%	950	20	20	300	250	1.0	2.0	3RP470-8
3RP600L-8	3RP600M-8	600 $\pm$ 20%	1300	20	20	300	250	1.0	2.0	3RP600-8

**Electrical Ratings**

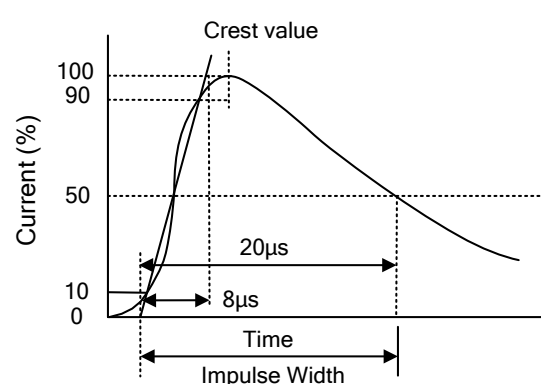
Items	Test Condition/Description	Requirement
DC Spark-over Voltage	The voltage is measured with voltage ramp $dv/dt=100V/s$ . Test is between each side electrode and center electrode.	To meet the specified value
Maximum Impulse Spark-over Voltage	The maximum impulse spark-over voltage is measured with voltage ramp $dv/dt=1000V/\mu s$ . Test is between each side electrode and center electrode.	
Impulse Discharge Current	Maximum surge current that can be applied through center electrode with 8/20 $\mu s$ waveform, for 10 times with 3min interval time, which will be equally divided between each side electrode to center electrode.  	
Alternating Discharge Current	Rated RMS value of AC current at 50Hz, 1 sec. for 10 times with interval time 3 min. Test is between each side electrode and center electrode.	
Insulation Resistance	The resistance of gas tube shall be measured between each side electrodes and center electrode.	
Capacitance	The capacitance of gas tube shall be measured between each side electrodes and center electrode. Test frequency: 1MHz	

**Recommended Soldering Conditions**

**Wave Soldering**

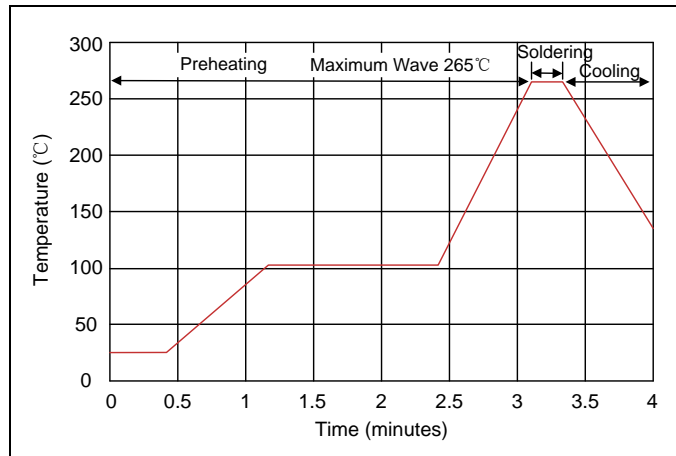

Item	Conditions
Peak Temperature	265°C
Dipping Time	10 seconds
Soldering	1 time

**Reflow Soldering**

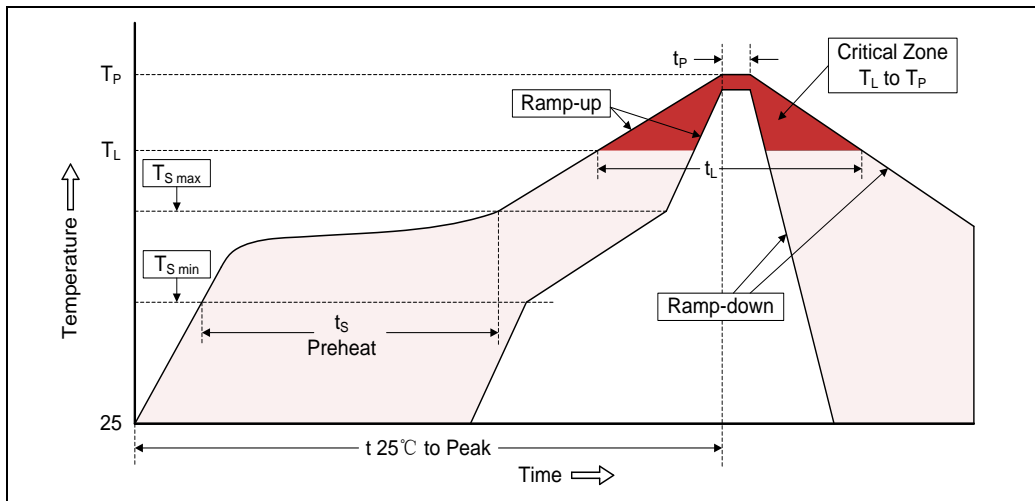

Profile Feature	Pb-Free Assembly
Average ramp-up rate ( $T_L$ to $T_P$ )	3°C/second max.
Preheat -Temperature Min ( $T_{S\ min}$ ) -Temperature Max ( $T_{S\ max}$ ) -Time (min to max) ( $t_s$ )	150°C 200°C 60-180 seconds
$T_{S\ max}$ to $T_L$ -Ramp-up Rate	3°C/second max.
Time maintained above: -Temperature ( $T_L$ ) -Time ( $t_L$ )	217°C 60-150 seconds
Peak Temperature ( $T_P$ )	260°C
Time within 5°C of actual Peak Temperature ( $t_p$ )	20-40 seconds
Ramp-down Rate	6°C/second max.
Time 25°C to Peak Temperature	8 minutes max.

**Packaging**

Axial Packing (Box)

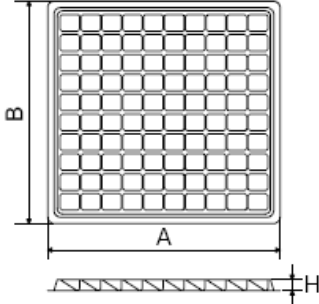
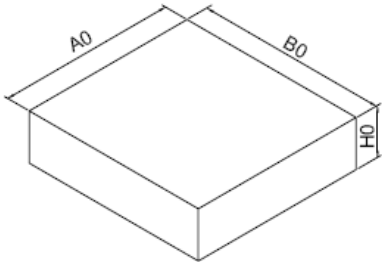
Skin packing 	Dimension (mm)	
	Symbol	Spec. / Tolerance
	A	217.0 ±2.0
	B	207.0 ±2.0
	H	10.3 ±0.5
Quantity: 100pcs		
Inner box 	A0	225.0 ±2.0
	B0	210.0 ±2.0
	H0	60.0 ±2.0
	Quantity: 500pcs	

SMD Packing (Tape & Reel)

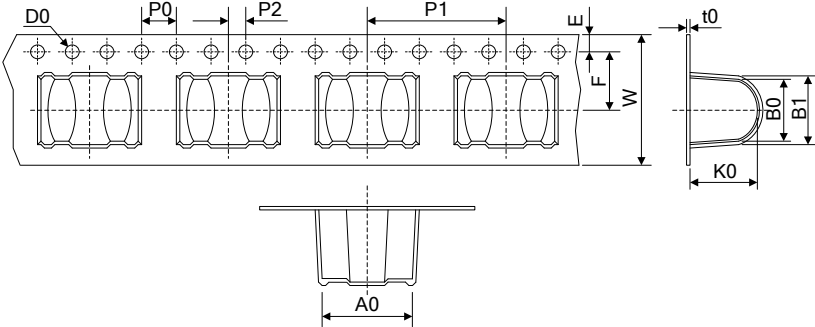
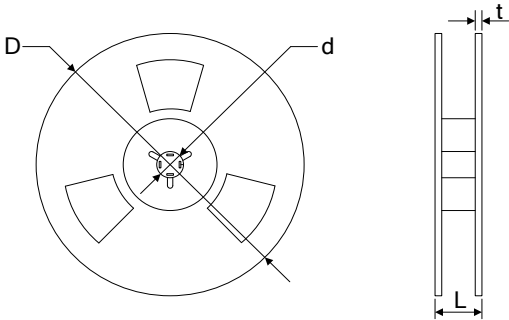
Tape 	Dimension (mm)	
	Symbol	Spec. / Tolerance
	W	16.00 ±0.20
	P0	4.00 ±0.10
	P1	16.00 ±0.10
	P2	2.00 ±0.10
	D0	1.55 ±0.05
	E	1.75 ±0.10
	F	7.50 ±0.10
	A0	11.60 ±0.10
	K0	8.90 ±0.10
	B0	8.60 ±0.10
	B1	10.00 ±0.10
	t0	0.50 ±0.05
Reel 	D	330.00 ±2.00
	d	13.00 ±0.50
	L	20.00 ±2.00
	t	2.00 ±0.20
	Quantity: 300pcs	