



承 认 书

APPROVAL SHEET

客户名称

CUSTOMER : _____

产品名称

柔性端头多层片式陶瓷电容器

PART NAME: _____ **MLCC WITH FLEX ITERM**

规格

SPECIFICATION: _____ **0603~2225 TYPE**

版本

VERSION: _____

日期

DATE OF ISSUE: _____

制 造 MANUFACTURER			客 户 CUSTOMER		
拟制 DESIGN	审核 CHECK	批准 APPROVAL	检验 INSPECTOR	审核 CHECK	批准 APPROVAL



柔性端头多层片式陶瓷电容器 MLCC WITH FLEX ITEM

一、特性

- ※ 具有高强度的抗弯曲性能，下弯可达到 3mm。
- ※ 可增加温度周期变化次数，最多 3000 次。
- ※ 采用柔性端头体系。
- ※ 可减少线路板因弯曲导致的失效故障。

● 应用范围

- ※ 应用于高弯曲的线路板。
- ※ 应用于温度变化的线路。
- ※ 应用于汽车推进系统。

一、FEATURE

- ※ High mechanical performance able to withstand, 3mm bend test.
- ※ Increased temperature cycling performance, 3000 cycles and beyond.
- ※ Flexible termination system.
- ※ Reduction in circuit board flex failures.

● APPLICATIONS

- ※ High Flexure Stress Circuit Boards.
- ※ Variable Temperature Applications.
- ※ Automotive Applications.

二、结构及尺寸 STRUCTURE AND DIMENSIONS

※ 尺寸 DIMENSIONS

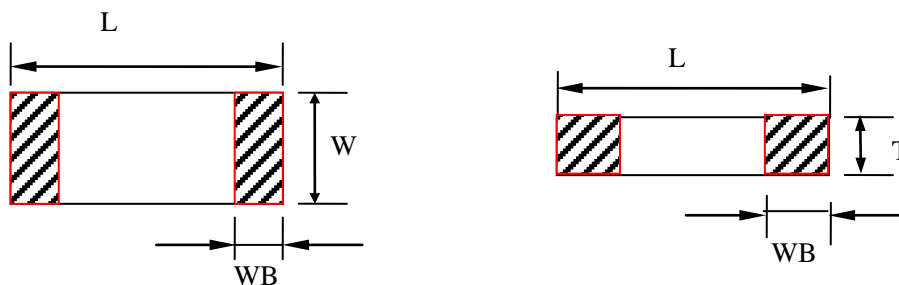



型号 Type		尺寸 Dimensions (mm)				特别说明 Special Instructions
英制表示 British expression	公制表示 Metric expression	L	W	T	WB	
0603	1608	1.60±0.10	0.80±0.10	0.80±0.10	0.30±0.10	All
0805	2012	2.00±0.20	1.25±0.20	0.80±0.20	0.50±0.20	C < 1uF
		2.00±0.20	1.25±0.20	1.25±0.20	0.50±0.20	1uF ≤ C ≤ 4.7uF
1206	3216	3.20±0.30	1.60±0.30	0.80±0.20	0.60±0.30	C ≤ 1uF
		3.20±0.30	1.60±0.30	1.00±0.20	0.60±0.30	1uF < C ≤ 2.2uF
		3.20±0.30	1.60±0.30	1.25±0.20	0.60±0.30	2.2uF < C < 4.7uF
		3.20±0.30	1.60±0.30	1.60±0.30	0.60±0.30	C ≥ 4.7uF
1210	3225	3.20±0.30	2.50±0.30	≤ 2.80	0.60±0.30	All
1808	4520	4.50±0.40	2.00±0.20	≤ 2.20	0.60±0.30	All
1812	4532	4.50±0.40	3.20±0.30	≤ 3.50	0.60±0.30	All
2220	5750	5.70±0.40	5.00±0.40	≤ 3.50	0.60±0.30	All
2225	5763	5.70±0.50	6.30±0.50	≤ 6.20	0.60±0.30	All
3012	7632	7.60±0.50	3.20±0.30	≤ 8.10	0.60±0.30	All

备注：1、产品具体厚度“T”查阅本承认书中“容量范围及其电压”。

2、可根据客户的特殊要求设计符合客户需求的产品。

Note: 1、The specific thickness of the product can read "capacity range and voltage" in this approval sheet.

2、We can design according to customer special requirements

※ 结构 STRUCTURE

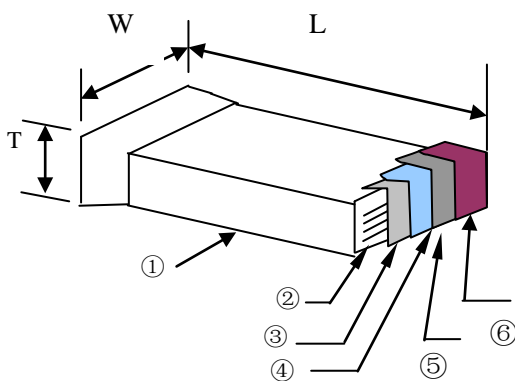

序号 NO	名称 Name	序号 NO	名称 Name
①	陶瓷介质 Ceramic dielectric	④	导电性树脂 Conductive Resin
②	内电极 Inner electrode	⑤	镍层 Nickel Layer
③	外电极 Substrate electrode	⑥	锡层 Tin Layer

三、型号规格表示方法 HOW TO ORDER

0805 B 222 K 500 A T
 ① ② ③ ④ ⑤ ⑥ ⑦



※说明 NOTES:

①尺寸 DIMENSIONS

单位 (unit): inch/ mm

尺寸规格 Size Code	0603	0805	1206	1210	1808	1812	2220	2225
长×宽 (L×W) inch	0.06×0.03	0.08×0.05	0.12×0.06	0.12×0.10	0.18×0.08	0.18×0.12	0.22×0.20	0.22×0.25
长×宽 (L×W) mm	1.60×0.80	2.00×1.25	3.20×1.60	3.20×2.50	4.50×2.00	4.50×3.20	5.70×5.00	5.70×6.30

② 介质种类 DIELECTRIC STYLE

介质种类(Dielectric Code)	CG	B
介质材料 (Dielectric)	COG 或 NPO	X7R

③ 标称容量 NOMINAL CAPACITANCE

位(unit): pF

表示方式 (Express Method)	实际值 (Actual Value)	注: 头两位数字为有效数字, 第三位数字为 0 的个数; R 为小数点。 Note: the first two digits are significant; third digit denotes number of zeros; R=decimal point.
102	10×10^2	
222	22×10^2	

④ 容量误差 CAPACITANCE TOLERANCE

代码 (Code)	J	K	M
误差 (Tolerance)	± 5.0%	± 10.0%	± 20%

⑤ 额定工作电压 Rated Voltage

单位(unit): V

表示方式 (Express Method)	实际值 (Actual Value)	注: 头两位数字为有效数字, 第三位数字为 0 的个数; R 为小数点。 Note: the first two digits are significant; third digit denotes number of zeros; R=decimal point.
500	50V	

⑥ 端头材料 TERMINAL MATERIAL STYLES

端头类别 (Termination Styles)	表示方式 (Express Method)
柔性端头多层片式陶瓷电容器 MLCC with (FLEXITERM Solderable Termination)	A

⑦ 包装方式 PACKAGE STYLES

B	T
散包装 (Bulk Bag)	编带包装 (Taping Package)



四、常规容量范围及其电压 Capacitance Range and Operating Voltage

单位/unit: pF

尺寸规格 Size Code	额定电压 Rated Voltage	容量范围 Capacitance	
		C0G(NPO) (PF)	X7R (PF)
0603	50V	0.1~4,700 【0.8】	100~470,000 【0.8】
	25V	0.1~4,700 【0.8】	100~1,000,000 【0.8】
	16V/10V/6.3V	0.1~4,700 【0.8】	100~2,200,000 【0.8】
0805	50V	0.1~4,700 【0.7】 5,600~8,200 【0.8】 10,000 【1.25】	100~470,000 【0.8】 560,000~1,000,000 【1.25】
	25V	10,000 【1.25】	560,000~2,200,000 【1.25】
	16V/10V/6.3V	10,000 【1.25】	560,000~4,700,000 【1.25】
1206	50V	0.5~8,200 【0.7】 10,000~12,000 【1.6】	100~1,800,000 【0.8】 2,000,000~3,300,000 【1.25】 3,900,000~4,700,000 【1.6】
	25V	10,000~33,000 【1.6】	100~1,800,000 【0.8】 2,000,000~3,300,000 【1.25】 3,900,000~4,700,000 【1.6】
	16V/10V/6.3V	10,000~33,000 【1.6】	100~1,800,000 【0.8】 2,000,000~3,300,000 【1.25】 3,900,000~10,000,000 【1.6】
1210	50V	10~8,200 【1.25】	220~470,000 【1.25】 560,000~1,000,000 【1.6】
	25V	10~10,000 【1.25】	220~470,000 【1.25】 560,000~2,200,000 【1.6】
	16V/10V/6.3V	10~10,000 【1.25】	220~470,000 【1.25】 560,000~3,300,000 【1.6】



常规容量范围及其电压 Capacitance Range and Operating Voltage

单位/unit: pF

尺寸规格 Size Code	额定电压 Rated Voltage	容量范围 Capacitance	
		C0G(NPO) (PF)	X7R (PF)
1808	50V	10~6,800 【1.6】	220~1,000,000 【1.6】
	25V/16V	10~10,000 【1.6】	220~2,200,000 【1.6】
	10V/6.3V	10~10,000 【1.6】	220~4,700,000 【1.6】
1812	50V	10~12,000 【1.25】	470~1,000,000 【1.6】 1,200,000~2,200,000 【2.5】
	25V/16V	10~15,000 【1.25】	470~1,000,000 【1.6】 1,200,000~6,800,000 【2.5】
	10V/6.3V	10~15,000 【1.25】	——
2220	6.3V/10V/16V	10~47,000 【1.6】	470~10,000,000 【1.6】
2225	25V	10~47,000 【1.6】	470~4,700,000 【1.6】
	50V	10~33,000 【1.6】	470~3,300,000 【1.6】

备注：1、【】中表示对应容量的产品厚度，单位：mm

2、可根据客户的特殊要求设计符合客户需求的产品

Note: 1、【】 Corresponds to the capacity of the thickness of the product, unit: mm

2、We can design according to the customer requirements.



五、中高压容量范围及其电压 Capacitance Range and Operating Voltage

单位/unit: pF

尺寸规格 Size Code	额定电压 Rated Voltage	容量范围 Capacitance	
		COG(NPO) (PF)	X7R (PF)
0603	100V	0.5~820 【0.8】	150~22,000 【0.8】
	200V/250V	0.5~470 【0.8】	150~10,000 【0.8】
0805	100V	0.5~1,500 【0.8】	150~47,000 【0.8】 56,000~100,000 【1.25】
	200V/250V	0.1~1,000 【0.8】 1,200~1,500 【1.25】	150~18,000 【0.8】 20,000~22,000 【1.25】
	500V/630V	0.1~330 【0.8】 470~560 【1.25】	150~6,800 【0.8】 8,200~10,000 【1.25】
	1000V	0.1~100 【1.25】	-----
1206	100V	0.5~3,300 【0.8】	150~56,000 【0.8】 68,000~330,000 【1.25】
	200V	0.1~1,800 【0.8】 2,000~2,700 【1.25】	150~27,000 【0.8】 33,000~120,000 【1.25】
	250V	0.1~1,800 【0.8】 2,000~2,700 【1.25】	150~27,000 【0.8】 33,000~100,000 【1.25】
	500V/630V	0.1~10 【0.8】 11~470 【1】 560~1,500 【1.25】	150~2,700 【0.8】 3,300~33,000 【1.25】
	1000V	0.1~120 【1】 150~1,000 【1.25】	150~1,000 【0.8】 150~10,000 【1.25】
	2000V	0.1~39 【1】 47~68 【1.25】 82~270 【1.6】	150~2,700 【1.25】



中高压容量范围及其电压 **Capacitance Range and Operating Voltage**

单位/unit: pF

尺寸规格 Size Code	额定电压 Rated Voltage	容量范围 Capacitance	
		COG(NPO) (PF)	X7R (PF)
1210	100V	1.0~4,700 【1.25】	150~220,000 【1.25】 330,000~1,000,000 【1.6】
	200V/250V	1.0~3,300 【1.25】	150~220,000 【1.25】
	500V/630V	1.0~1,200 【1.25】 1,500~2,200 【1.6】	150~56,000 【1.25】
	1000V	1.0~680 【1.25】 820 【1.6】	150~3,900 【1.25】 4,700~22,000 【1.6】
	2000V	1.0~270 【1.25】 300~470 【1.6】	150~2,700 【1.25】 3,300~6,800 【1.6】
1808	100V	2.0~4,700 【1.6】	150~1,000,000 【1.6】
	200V/250V	2.0~3,300 【1.6】	150~220,000 【1.6】
	500V/630V	2.0~1,800 【1.6】	150~100,000 【1.6】
	1000V	2.0~820 【1.6】	150~22,000 【1.6】
	2000V	2.0~470 【1.6】	150~10,000 【1.6】
	3000V	2.0~330 【1.6】	150~3,300 【1.6】
	4000V	2.0~33 【1.6】	150~2,200 【1.6】
	5000V	2.0~27 【1.6】	-----



中高压容量范围及其电压 Capacitance Range and Operating Voltage

单位/unit: pF

尺寸规格 Size Code	额定电压 Rated Voltage	容量范围 Capacitance	
		COG(NPO) (PF)	X7R (PF)
1812	100V	3.0~10,000 【1.25】	150~560,000 【1.6】 680,000~1,000,000 【2】
	200V	3.0~5,600 【1.25】	150~220,000 【1.6】 330,000~560,000 【2】 680,000~1,000,000 【2.5】
	250V	3.0~5,600 【1.25】	150~220,000 【1.6】 330,000~560,000 【2】 680,000~820,000 【2.5】
	500V/630V	3.0~1,000 【1.25】 1,200~3,900 【1.6】	150~100,000 【1.6】 120,000~220,000 【2】
	1000V	3.0~1,200 【1.6】	150~47,000 【1.6】
	2000V	3.0~680 【1.6】	150~12,000 【1.6】
	3000V	3.0~470 【1.6】	150~4,700 【1.6】
	4000V	3.0~220 【1.6】	150~3,300 【1.6】
	5000V	3.0~56 【1.6】	-----
2220 2225	100V	5.0~27,000 【1.6】	150~2,200,000 【1.6】
	200V~250V	5.0~12,000 【1.6】	150~1,000,000 【1.6】
	500V~630V	5.0~6,800 【1.6】	150~470,000 【1.6】
	1000V	5.0~2,200 【1.6】	150~33,000 【1.6】 39,000~56,000 【2】
	2000V	5.0~1,000 【1.6】	150~6,800 【1.6】 22,000~33,000 【2】
	3000V	5.0~680 【1.6】	150~12,000 【1.6】
	4000V	5.0~560 【1.6】	150~6,800 【1.6】
	5000V	5.0~100 【1.6】	-----

备注: 1、【】中表示对应容量的产品厚度, 单位: mm

2、可根据客户的特殊要求设计符合客户需求的产品

Note: 1、【】 Corresponds to the capacity of the thickness of the product, unit: mm

2、We can design according to the customer requirements.



六、可靠性测试 Reliability Test

项目 Item	技术规格 Technical Specification		测试方法 Test Method and Remarks		
容量 Capacitance	I类 Class I	应符合指定的误差级别 Should be within the specified tolerance.	标称容量 Capacitance	测试频率 Measuring Frequency	测试电压 Measuring Voltage
			≤1000pF	1MHz±10%	1.0±0.2Vrms
			>1000 pF	1KHz±10%	
	II类 Class II	应符合指定的误差级别 Should be within the specified tolerance.	测试温度: 25°C±3°C Test Temperature: 25°C±3°C C≤10μF: 测试频率: 1KHz±10% 测试电压: 1.0±0.2Vrms Test Frequency: 1KHz±10% Test Voltage: 1.0±0.2Vrms C>10μF: 测试频率: 120±24 Hz 测试电压: 0.5±0.1Vrms Test Frequency: 120±24 Hz Test Voltage: 0.5±0.1Vrms		
损耗角正切 (DF, tan δ) Dissipation Factor	I类 Class I	DF	标称容量 Capacitance	测试频率 Measuring Frequency	测试电压 Measuring Voltage
		≤0.56%	Cr<5 pF	1MHz±10%	1.0±0.2Vrms
		$11.5[(150/Cr)+7] \times 10^{-4}$	5pF≤Cr<50 pF	1MHz±10%	
		≤0.15%	50pF≤Cr≤1000 pF	1MHz±10%	
		≤0.15%	>1000 pF	1KHz±10%	



项目 Item	技术规格 Technical Specification						测试方法 Test Method and Remarks	
损耗角正切 (DF, tan δ) Dissipation Factor	II类 Class II	X7R	≥50V	25V	16V	10V	63V	C ≤ 10μF 测试频率: 1KHz ± 10% 测试电压: 1.0 ± 0.2Vrms Test Frequency: 1KHz ± 10% Test Voltage: 1.0 ± 0.2Vrms C > 10μF 测试频率: 120 ± 24 Hz 测试电压: 0.5 ± 0.1Vrms Test Frequency: 120 ± 24Hz Test Voltage: 0.5 ± 0.1Vrms
			≤2.5% (C < 0.47μF) ≤5.0% (C ≥ 0.47μF)	≤3.5% (C < 0.47μF) ≤10.0% (C ≥ 0.47μF)	≤3.5% (C < 0.47μF) ≤10.0% (C ≥ 0.47μF)	≤5.0% (C < 0.15μF) ≤10.0% (C ≥ 0.15μF)	≤5.0% (C < 0.15μF) ≤10.0% (C ≥ 0.15μF)	
绝缘电阻 (IR) Insulation Resistance	I类 Class I	C ≤ 10 nF, Ri ≥ 50000M Ω		C > 10 nF, Ri • Cr ≥ 500S		测试电压: 额定电压 (最高 500V) 测试时间: 60 ± 5 秒 测试湿度: ≤75% 测试温度: 25°C ± 3°C 测试充放电电流: ≤50mA Measuring Voltage: Rated Voltage (Max 500V) Duration: 60 ± 5s Test Humidity: ≤75% Test Temperature: 25°C ± 3°C Test Current: ≤50mA		
	II类 Class II	X7R	C ≤ 25 nF, Ri ≥ 10000M Ω		C > 25 nF, Ri • Cr > 100S			
介质耐电强度 (DWV) Dielectric Withstanding Voltage	不应有介质被击穿或损伤 No breakdown or damage.			测量电压: Ur < 100V: I类: 300%额定电压 II类: 250%额定电压 100V ≤ Ur < 500V: 200%额定电压 500V ≤ Ur ≤ 1000V: 150%额定电压 Ur > 1000V: 120%额定电压 时间: 1~5 秒 充/放电电流: 不应超过 50mA Measuring Voltage: Ur < 100V: Class I :300% Rated voltage Class II :250% Rated voltage 100V ≤ Ur < 500V: 200% Rated voltage 500V ≤ Ur ≤ 1000V: 150% Rated voltage Ur > 1000V: 120% Rated voltage Duration: 1~5s Charge/ Discharge Current: 50mA max.				



项目 Item	技术规格 Technical Specification		测试方法 Test Method and Remarks
可焊性 Solderability	上锡率应大于 95% 外观: 无可见损伤. At least 95% of the terminal electrode is covered by new solder. Visual Appearance: No visible damage.		将电容在 80~120°C 的温度下预热 10~30 秒. Preheating conditions: 80 to 120°C; 10~30s.
			有铅焊料: (Sn/Pb: 63/37) 浸锡温度: 235±5°C 浸锡时间: 2±0.5s Solder Temperature: 235±5°C Duration: 2±0.5s
耐焊接热 Resistance to Soldering Heat	项目 Item	NPO 至 SL NPO to SL	X7R
	ΔCC	≤ ± 0.5% 或 ± 0.5PF, 取较大值 ≤ ± 0.5% or ± 0.5PF, whichever is larger	-5~+10%
	DF	同初始标准 Same to initial value.	
	IR	同初始标准 Same to initial value.	
	外观: 无可见损伤 上锡率: ≥95% Appearance: No visible damage. At least 95% of the terminal electrode is covered by new solder.		将电容在 100~200°C 的温度下预热 10±2 分钟. 浸锡温度: 265±5°C 浸锡时间: 10±1s 然后取出溶剂清洗干净, 在 10 倍以上的显微镜底下观察. 放置时间: 24±2 小时 放置条件: 室温 Preheating conditions: 100 to 200°C; 10±2min. Solder Temperature: 265±5°C Duration: 10±1s Clean the capacitor with solvent and examine it with a 10X(min.) microscope. Recovery Time: 24±2h Recovery condition: Room temperature
端头结合强度 Termination Adhesion	外观无可见损伤 No visible damage.		施加的力: 5N 时间: 10±1S Applied Force: 5N Duration: 10±1S

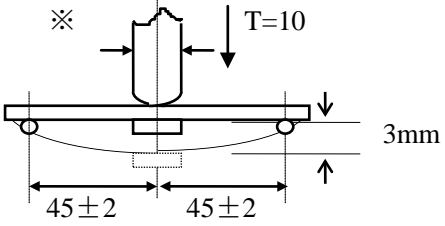

项目 Item	技术规格 Technical Specification	测试方法 Test Method and Remarks																														
抗弯曲强度 Resistance to Flexure of Substrate (Bending Strength)	外观：无可见损伤。 Appearance: No visible damage. <table border="1" data-bbox="288 831 778 1093"> <tr> <td>$\Delta C/C$</td> <td>$\leq \pm 10\%$</td> </tr> </table>	$\Delta C/C$	$\leq \pm 10\%$	试验基板：Al ₂ O ₃ 或 PCB 弯曲深度：3mm 施压速度：0.5mm/sec. 单位：mm 应在弯曲状态下进行测量。  Test Board: Al ₂ O ₃ or PCB Warp: 3mm Speed: 0.5mm/sec. Unit: mm The measurement should be made with the board in the bending position.																												
$\Delta C/C$	$\leq \pm 10\%$																															
温度循环 Temperature Cycle	$\Delta C/C$: I 类： $\leq \pm 1\%$ 或 $\pm 1pF$ ， 取两者中最大者 II 类： B: $\leq \pm 10\%$ Class I : $\leq \pm 1\%$ or $\pm 1pF$, whichever is larger. Class II : B: $\leq \pm 10\%$	预处理* (2 类)：上限类别温度，1 小时 恢复：24 ± 1h 初始测量 循环次数：5 次，一个循环分以下 4 步： <table border="1" data-bbox="802 1240 1382 1516"> <thead> <tr> <th>阶段</th> <th>温度 (°C)</th> <th>时间 (分钟)</th> </tr> </thead> <tbody> <tr> <td>第 1 步</td> <td>下限温度 (-55)</td> <td>30</td> </tr> <tr> <td>第 2 步</td> <td>常温 (+20)</td> <td>2~3</td> </tr> <tr> <td>第 3 步</td> <td>上限温度 (125)</td> <td>30</td> </tr> <tr> <td>第 4 步</td> <td>常温 (+20)</td> <td>2~3</td> </tr> </tbody> </table> 试验后放置 (恢复) 时间：24 ± 2h Preheating conditions: up-category temperature, 1h Recovery time: 24 ± 1h Initial Measurement Cycling Times: 5 times, 1 cycle, 4 steps: <table border="1" data-bbox="802 1704 1445 2029"> <thead> <tr> <th>Step</th> <th>Temperature (°C)</th> <th>Time (min.)</th> </tr> </thead> <tbody> <tr> <td>1</td> <td>Low- category temp. (-55)</td> <td>30</td> </tr> <tr> <td>2</td> <td>Normal temp. (+20)</td> <td>2~3</td> </tr> <tr> <td>3</td> <td>Up- category temp. (125)</td> <td>30</td> </tr> <tr> <td>4</td> <td>Normal temp. (+20)</td> <td>2~3</td> </tr> </tbody> </table> Recovery time after test: 24 ± 2h	阶段	温度 (°C)	时间 (分钟)	第 1 步	下限温度 (-55)	30	第 2 步	常温 (+20)	2~3	第 3 步	上限温度 (125)	30	第 4 步	常温 (+20)	2~3	Step	Temperature (°C)	Time (min.)	1	Low- category temp. (-55)	30	2	Normal temp. (+20)	2~3	3	Up- category temp. (125)	30	4	Normal temp. (+20)	2~3
阶段	温度 (°C)	时间 (分钟)																														
第 1 步	下限温度 (-55)	30																														
第 2 步	常温 (+20)	2~3																														
第 3 步	上限温度 (125)	30																														
第 4 步	常温 (+20)	2~3																														
Step	Temperature (°C)	Time (min.)																														
1	Low- category temp. (-55)	30																														
2	Normal temp. (+20)	2~3																														
3	Up- category temp. (125)	30																														
4	Normal temp. (+20)	2~3																														



项目 Item	技术规格 Technical Specification		测试方法 Test Method and Remarks
潮湿试验 Moisture Resistance	$\Delta C/C$	I 类: $\leq \pm 2\%$ 或 $\pm 1pF$, 取两者之中较大者 II 类: B: $\leq \pm 10\%$ Class I : $\leq \pm 2\%$ or $\pm 1pF$, whichever is larger. Class II : B: $\leq \pm 10\%$	温度: $40 \pm 2^\circ C$ 湿度: 90~95%RH 时间: 500 小时 放置条件: 室温 放置时间: 24 小时(I 类); 48 小时(II 类) Temperature: $40 \pm 2^\circ C$ Humidity: 90~95%RH Duration: 500h Recovery conditions: Room temperature Recovery Time: 24h (Class1) or 48h (Class2)
	DF	≤ 2 倍初始标准 Not more than twice of initial value.	
	IR	I 类: $R_i \geq 2500M\Omega$ 或 $R_i \cdot C_R \geq 25S$ 取 两者之中较小者. Class I : $R_i \geq 2500M\Omega$ 或 $R_i \cdot C_R \geq 25S$ whichever is smaller.	
		II 类: $R_i \geq 1000M\Omega$ 或 $R_i \cdot C_R \geq 25S$ 取 两者之中较小者. Class II : $R_i \geq 1000M\Omega$ 或 $R_i \cdot C_R \geq 25S$ whichever is smaller.	
外观: 无损伤 Appearance: No visible damage.			
寿命试验 Life Test	$\Delta C/C$	I 类: $\leq \pm 2\%$ 或 $\pm 1pF$ 取两者之中较大者 II 类: B: $\leq \pm 20\%$ Class I : $\leq \pm 2\%$ or $\pm 1pF$, whichever is larger. Class II : B: $\leq \pm 20\%$	低压产品 ($\leq 100V$) 电压: 1.5 倍额定工作电压 时间: 1000 小时 温度: $125^\circ C$ 充电电流: 不应超过 50mA 放置条件: 室温 放置时间: 24 小时 (I 类), 或 48 小时 (II 类), Low-Voltage ($\leq 100V$) Applied Voltage: $1.5 \times$ Rated Voltage Duration: 1000h Temperature: $125^\circ C$ Charge/ Discharge Current: 50mA max. Recovery Conditions: Room Temperature Recovery Time: 24h (Class 1), or 48h (Class2)
	DF	≤ 2 倍初始标准 Not more than twice of initial value.	
	IR	I 类: $R_i \geq 4000M\Omega$ 或 $R_i \cdot C_R \geq 40S$ 取 两者之中较小者. Class I : $R_i \geq 4000M\Omega$ 或 $R_i \cdot C_R \geq 40S$ whichever is smaller.	
		II 类: $R_i \geq 2000M\Omega$ 或 $R_i \cdot C_R \geq 50S$ 取 两者之中较小者. Class II : $R_i \geq 2000M\Omega$ 或 $R_i \cdot C_R \geq 50S$ whichever is smaller.	
外观: 无损伤 Visual Appearance: No visible damage.			



项目 Item	技术规格 Technical Specification		测试方法 Test Method and Remarks
中高压产品 寿命试验 Middle &high voltage Life Test	$\Delta C/C$	I 类: $\leq \pm 2\%$ 或 $\pm 1\text{pF}$ 取两者之中较大者 II 类: B: $\leq \pm 20\%$ Class I : $\leq \pm 2\%$ or $\pm 1\text{pF}$, whichever is larger. Class II : B: $\leq \pm 20\%$	中高压产品: $100\text{V} \leq \text{额定电压} < 500\text{V}$: 2 倍工作电压 $500\text{V} \leq \text{额定电压} \leq 1000\text{V}$: 1.5 倍工作电压 额定电压 $> 1000\text{V}$: 1.2 倍工作电压 时间: 1000 小时 充电电流: 不应超过 50mA
	DF	≤ 2 倍初始标准 Not more than twice of initial value.	温度: 125°C (NPO X7R); 85°C (X5R、Y5V) 放置条件: 室温
	IR	I 类: $R_i \geq 4000\text{M}\Omega$ 或 $R_i \cdot C_R \geq 40\text{S}$ 取两者之中较小者. Class I : $R_i \geq 4000\text{M}\Omega$ 或 $R_i \cdot C_R \geq 40\text{S}$ whichever is smaller.	放置时间: 24 小时 (I 类), 或 48 小时 (II类), Applied Voltage: $100\text{V} \leq \text{Rated Voltage} < 500\text{V}$: 2 Multiple $500\text{V} \leq \text{Rated Voltage} \leq 1000\text{V}$: 1.5 Multiple $> 1000\text{V}$ Rated Voltage: 1.2 Multiple Duration: 1000h Charge/ Discharge Current: 50mA max. Temperature: 125°C (NPO X7R); 85°C (X5R、Y5V)
		II 类: $R_i \geq 2000\text{M}\Omega$ 或 $R_i \cdot C_R \geq 50\text{S}$ 取两者之中较小者. Class II : $R_i \geq 2000\text{M}\Omega$ 或 $R_i \cdot C_R \geq 50\text{S}$ whichever is smaller.	
外观: 无损伤 Visual Appearance: No visible damage.		Recovery Conditions: Room Temperature Recovery Time: 24h (Class 1), or 48h (Class2)	

注解:

专门预处理* (仅对 2 类电容器):

将电容器放在上限类别温度或按详细规范中可能规定的更高温度下经 1h 后, 接着在试验的标准大气条件下恢复 $24 \pm 1\text{h}$ 。

Note: Pretreatment (only for class2 capacitor)

Pretreatment (only for class2 capacitor) is a method to treat the capacitor before measurement. First, place the capacitor in the up-category temperature or other specified higher temperature environment for 1hour. Then recovery the capacitor at standard pressure conditions for $24 \pm 1\text{hours}$ 。

※以最新版本的内容为准



七、包装 PACKAGE

●纸带卷盘结构 PAPER TAPING

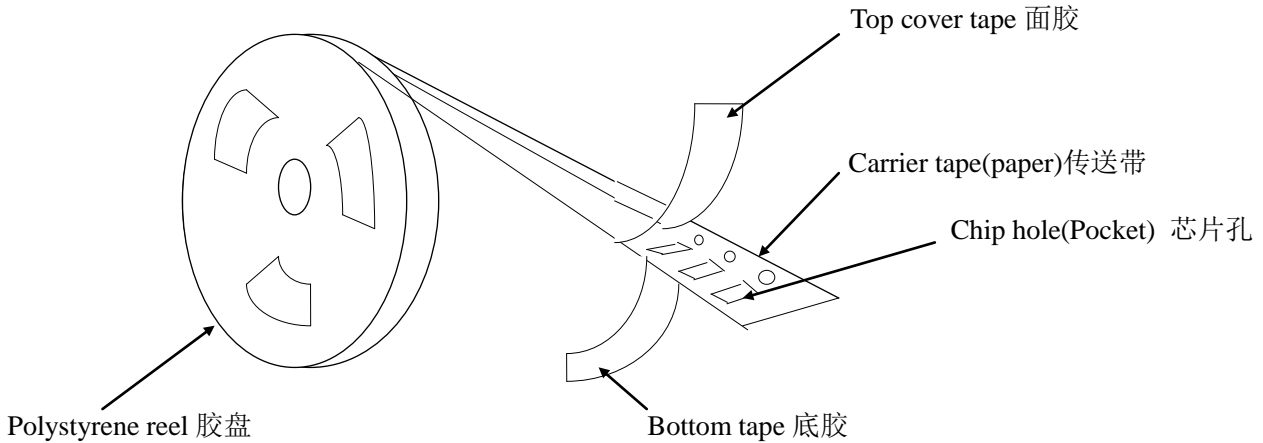

※适合‘0603, 0805, 1206’常规尺寸产品的纸带尺寸
Dimensions of paper taping for 0603, 0805, 1206 types.

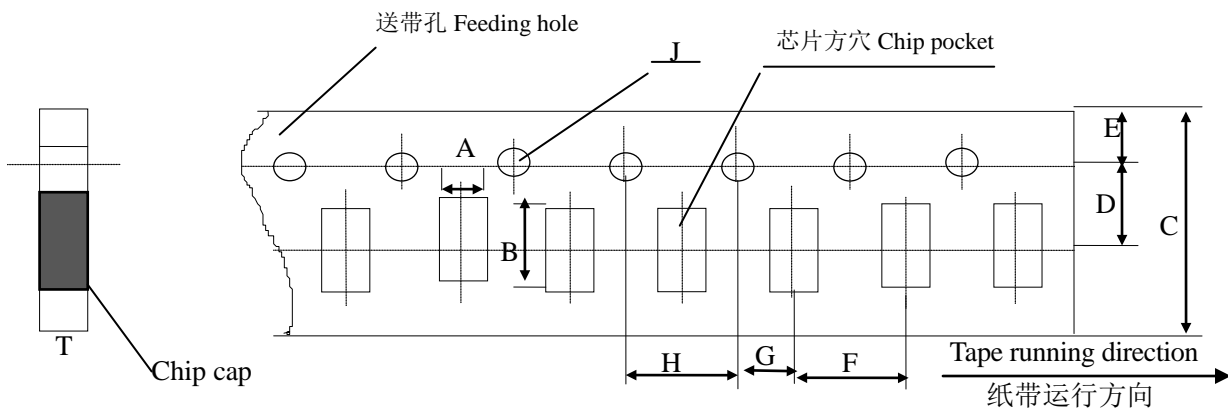

代号 Code 纸带规格 paper size	A	B	C	D*	E	F	G*	H	J	T
0603	1.10 ±0.10	1.90 ±0.10	8.00 ±0.10	3.50 ±0.05	1.75 ±0.10	4.00 ±0.10	2.00 ±0.10	4.00 ±0.10	1.50 -0/+0.10	1.10 Max
0805	1.45 ±0.15	2.30 ±0.15	8.00 ±0.15	3.50 ±0.05	1.75 ±0.10	4.00 ±0.10	2.00 ±0.10	4.00 ±0.10	1.50 -0/+0.10	1.10 Max
1206	1.80 ±0.20	3.40 ±0.20	8.00 ±0.20	3.50 ±0.05	1.75 ±0.10	4.00 ±0.10	2.00 ±0.10	4.00 ±0.10	1.50 -0/+0.10	1.10 Max

注意：*表示此处对尺寸的要求非常精确。

Note: The place with “*” means where needs exactly dimensions.



※塑胶带尺寸结构(适合‘0805~1812’型产品)

Dimensions of embossed tapping for 0805~1812 type

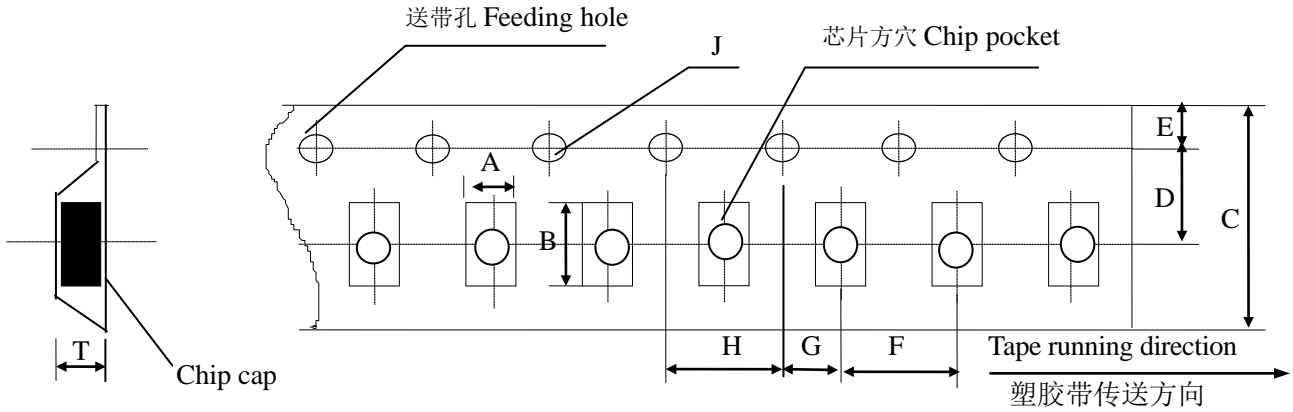

代号 Code	A	B	C	D*	E	F	G*	H	J	T
0805	1.55 ± 0.20	2.35 ± 0.20	8.00 ± 0.20	3.50 ± 0.05	1.75 ± 0.10	4.00 ± 0.10	2.00 ± 0.10	4.00 ± 0.10	1.50 -0/+0.10	1.50 Max
1206	1.95 ± 0.20	3.60 ± 0.20	8.00 ± 0.20	3.50 ± 0.05	1.75 ± 0.10	4.00 ± 0.10	2.00 ± 0.10	4.00 ± 0.1	1.50 -0/+0.10	1.85 Max
1210	2.70 ± 0.10	3.42 ± 0.10	8.00 ± 0.10	3.50 ± 0.05	1.75 ± 0.10	4.00 ± 0.10	2.00 ± 0.05	4.00 ± 0.10	1.55 -0/+0.10	3.2 Max
1808	2.20 ± 0.10	4.95 ± 0.10	12.00 ± 0.10	5.50 ± 0.05	1.75 ± 0.10	4.00 ± 0.10	2.00 ± 0.05	4.00 ± 0.10	1.50 -0/+0.10	3.0 Max
1812	3.66 ± 0.10	4.95 ± 0.10	12.00 ± 0.10	5.50 ± 0.05	1.75 ± 0.10	8.00 ± 0.10	2.00 ± 0.05	4.00 ± 0.10	1.55 -0/+0.10	4.0 Max

备注：*表示此处对尺寸的要求非常精确。

Note: The place with "*" means where needs exactly dimensions.

●传送带的前后结构 Structure of leader part and end part of the carrier paper

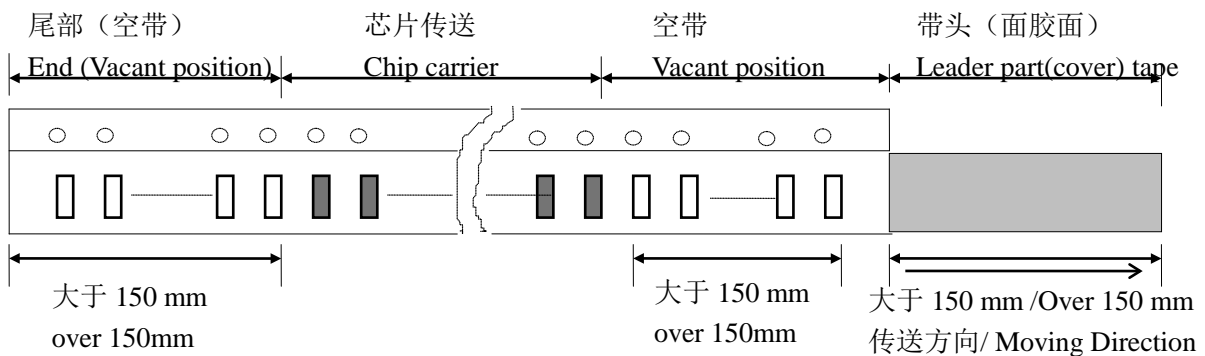



● 卷盘尺寸 Reel Dimensions (unit: mm)

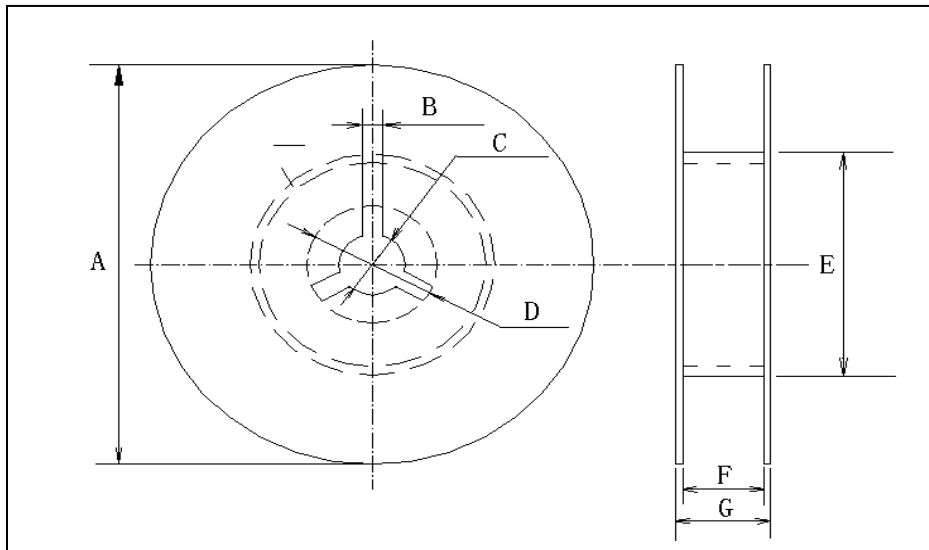

※尺寸代码 (CODE)

卷盘型号	A	B	C	D	E	F	G
7' REEL	$\phi 178 \pm 2.0$	3.0	$\phi 13 \pm 0.5$	$\phi 21 \pm 0.8$	$\phi 50$ 或更大 $\phi 50$ or more	100 ± 1.5	12max
13' REEL	$\phi 330 \pm 2.0$	3.0	$\phi 13 \pm 0.5$	$\phi 21 \pm 0.8$	$\phi 50$ 或更大 $\phi 50$ or more	100 ± 1.5	12max

● 关于卷带的说明 Taping specification

※面胶剥离强度 Top tape peeling strength

(a) 纸带 Paper Taping

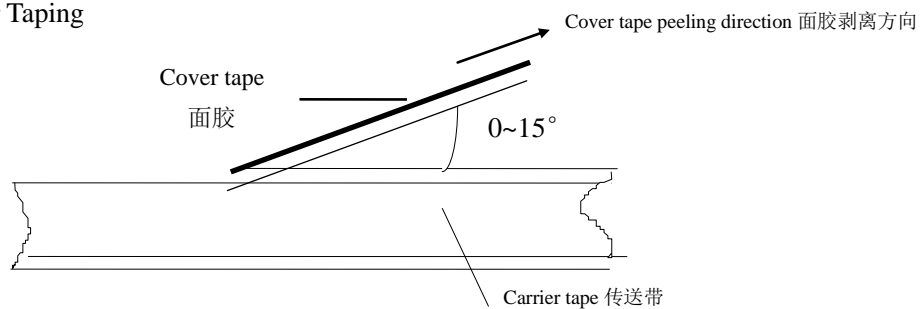

(b) 塑料胶盘 Embossed Taping

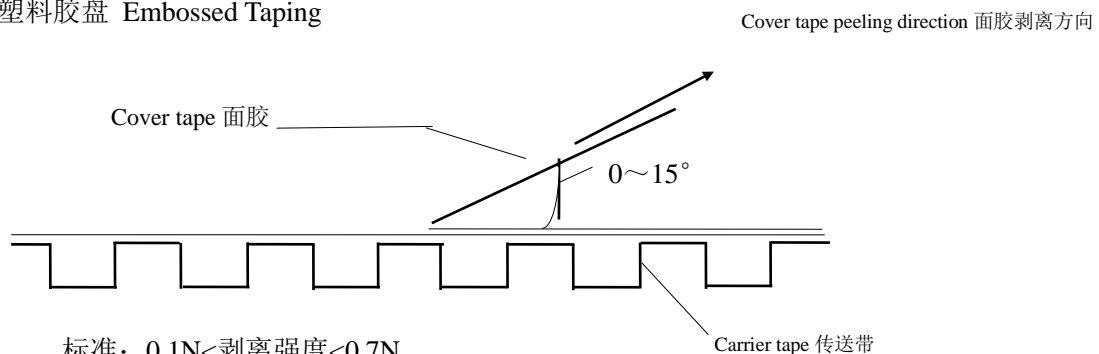

标准: $0.1N < \text{剥离强度} < 0.7N$

Standard: $0.1N < \text{peeling strength} < 0.7N$

在剥离时, 纸带不能有纸碎, 也不能粘在底、面胶上。

No paper dirty remains on the scotch when peeling, and sticks to top and bottom tape.



※塑料盒散包装 Bulk Case Package

单位 (unit) :mm

Symbol	A	B	T	C	D	E
Dimension	6.80±0.10	8.80±1.00	12.00±0.10	15.00+0.10/-0	2.00+0/-0.10	4.70±0.10
Symbol	F	W	G	H	L	I
Dimension	31.50+0.20/-0	36.00+0/-0.20	19.00±0.35	7.00±0.35	110.00±0.70	5.00±0.35

※ 包装数量 Packing Quantity

尺寸 (SIZE)	包装形式和数量 (PACKAGE STYLE & QUANTITY) unit: pcs			
	纸带卷盘 (PT)	胶带卷盘 (ET)	塑料盒散装 (BC)	一般散装 (BP)
0603	4000	-----	15000	5000
0805	4000	3000	10000	5000
1206	4000	T≤1.35mm 3000 T>1.35mm 2000	5000	5000
1210	-----	T≤1.80mm 2000 T>1.80mm 1000	-----	2000
1410	-----	2000	-----	-----
1808	-----	2000	-----	2000
1812	-----	T≤1.85mm 1000 T>1.85mm 500	-----	2000
1825、2220、 2025、2225、 3035	-----	500	-----	500

注意：包装的形式和数量可根据客户的要求来定。

Note: We can choose packing style and quantity can be according to the customer's requirement.



●外包装 Outer packing

小包装 The first package

Quantity: 10 reels

数量: 10 卷

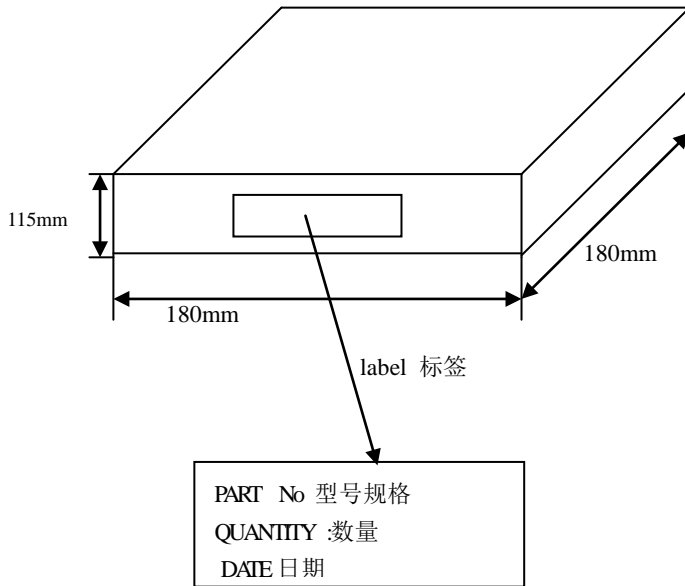

大包装 The second package

Quantity: 6 cases

数量: 6 盒

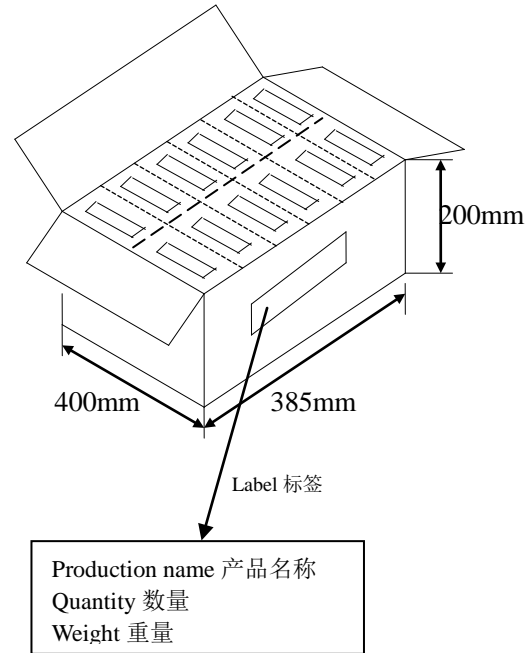

十、储存方法 Storage Methods

确保芯片可焊性良好的贮存期限为 6 个月(在包装好已交付的情况下)。

The guaranteed period for solderability is 6 months (Under deliver package condition).

储存条件/Storage conditions:

储存温度/Temperature 5~40℃

储存相对湿度/Relative Humidity 20~70%

十一、使用前的注意事项 Precautions For Use

多层片式瓷介电容器(MLCC)在短路或开路的电路中都有可能失效,在超出本承诺书或相关说明书中所述使用频率的恶劣工作环境,或外界机械力超压作用下,电容芯片都有可能着火、燃烧甚至爆炸,所以在使用的時候,首先应考虑按本承诺书的有关说明来进行,如有不明之处,请联系我们技术部、品管部或生产部。

The Multi-layer Ceramic Capacitors (MLCC) may fail in a short circuit modern in an open circuit mode when subjected to severe conditions of electrical environment and / or mechanical stress beyond the specified "rating" and specified "conditions" in the specification, which will result in burn out, flaming or glowing in the worst case. Following "precautions for "safety" and Application Notes shall be taken in your major consideration. If you have a question about the precautions for handling, please contact our engineering section or factory.

1. 焊接的条件与相关图表 Soldering Profile

为避免因温度的突然变化而引起的芯片开裂或局部爆炸的现象发生,请按有关温度曲线图表来进行。(请参考附页中的图表)

To avoid the crack problem by sudden temperature change, follow the temperature profile in the adjacent graph (refer to the graph in the enclosure page).



2. 手工焊接 Manual Soldering

手工焊接很容易因为芯片局部受热不均而引起瓷体微裂或局部爆炸的现象,在焊接时,如果操作者不小心,会使烙铁头直接同电容芯片的瓷体部分接触,这样很容易使电容芯片因热冲击而受损或出现其他意外.因此,使用电烙铁手工焊接时应仔细操作,并对电烙铁的尖端的选择和尖端温度控制应多加小心.

Manual soldering can pose a great risk of creating thermal cracks in capacitors. The hot soldering iron tip comes into direct contact with the end terminations, and operator's careless may cause the tip of the soldering iron to come into direct contact with the ceramic body of the capacitor. Therefore the soldering iron must be handled carefully, and pay much attention to the selection of the soldering iron tip and temperature contact of the tip.

3. 适量的焊料 Optimum Solder Amount for Reflow Soldering

焊料过多
Too much solder

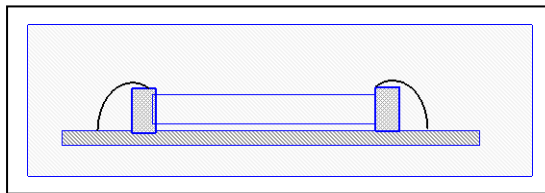

这样会因端头压力过大而可能引起芯片受损
Cracks tend to occur due to large stress.

焊料太少
Not enough solder

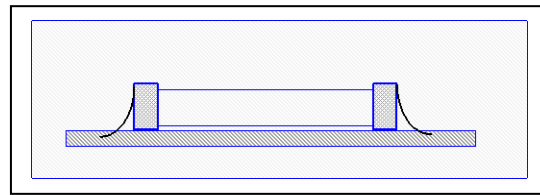

固定力量不足,可能会引起电容芯片与线路接触不良
Weak holding force may cause bad connection between the capacitor and PCB.

4. 推荐焊料用量 Recommended Soldering amounts

4.1 回流焊接的最佳焊料用量

The optimal solder fillet amounts for re-flow soldering

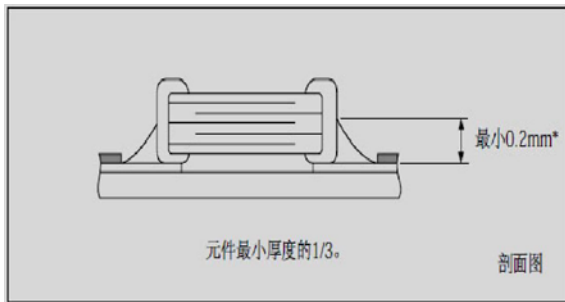

4.2 波峰焊接的最佳焊料用量

The optimal solder fillet amounts for wave soldering

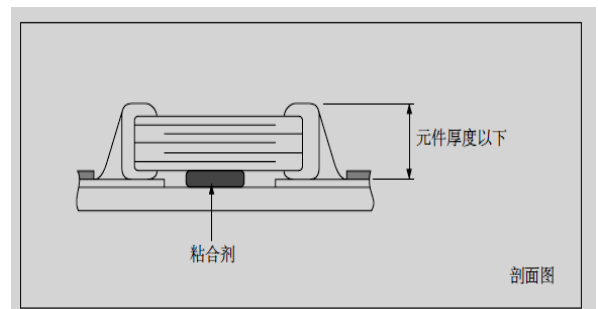

4.3 使用烙铁返修时的最佳焊料量

The optimal solder fillet amounts for reworking by using soldering iron

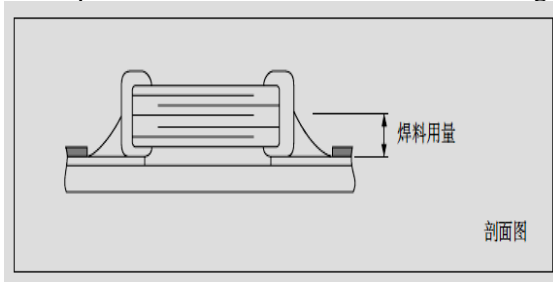



十二、推荐焊接方式 Recommended Soldering Method

规格尺寸 Size	温度特性 Temperature Characteristics	额定电压 Rated Voltage	容量范围 Capacitance	焊接方式 Soldering Method
0603	NPO	/	/	R/W
	X7R	/	$C \geq 1\mu\text{f}$	R
			$C < 1\mu\text{f}$	R/W
0805	NPO	/	/	R/W
	X7R	/	$C \geq 4.7\mu\text{f}$	R
			$C < 4.7\mu\text{f}$	R/W
1206	NPO	/	/	R/W
	X7R	/	$C \geq 10\mu\text{f}$	R
			$C < 10\mu\text{f}$	R/W
≥ 1210	NPO	/	/	R
	X7R	/	/	R

焊接方式 Soldering method: R—回流焊 Reflow Solering

W—波峰焊 Wave Soldering

十三、推荐焊接温度曲线图 The temperature profile for soldering

回流焊接 (Re-flow soldering)

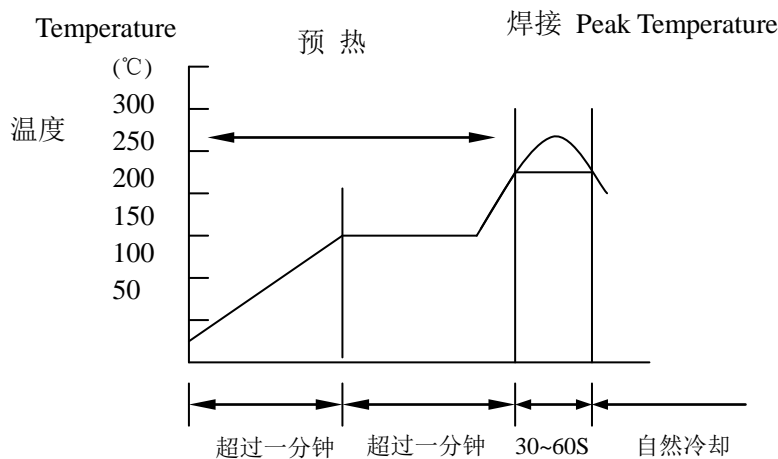

	Pb-Sn 焊接 Pb-Sn soldering	无铅焊接 Lead-free soldering
尖峰温度 Peak temperature	230°C~250°C	240°C~260°C

在预热时, 请将焊接温度与芯片表面温度之间的温差维持在 $T \leq 150^\circ\text{C}$ 。

While in preheating, please keep the temperature difference between soldering temperature and surface temperature of chips as: $T \leq 150^\circ\text{C}$.



波峰焊接 (Wave soldering)

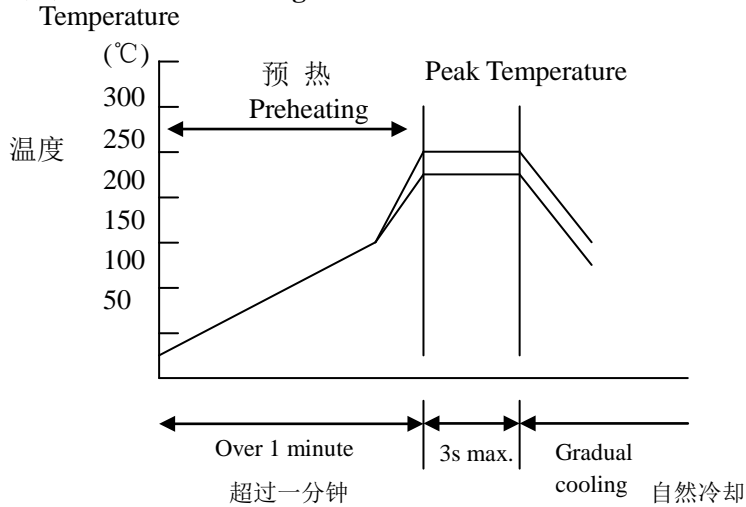

	Pb-Sn 焊接 Pb-Sn soldering	无铅焊接 Lead-free soldering
尖峰温度 Peak temperature	230°C ~ 260°C	240°C ~ 270°C

在预热时, 请将焊接温度与芯片表面温度之间的温差维持在 $T \leq 150^\circ\text{C}$ 。

While in preheating, please keep the temperature difference between soldering temperature and surface temperature of chips as: $T \leq 150^\circ\text{C}$.

手工焊接 (Hand soldering)

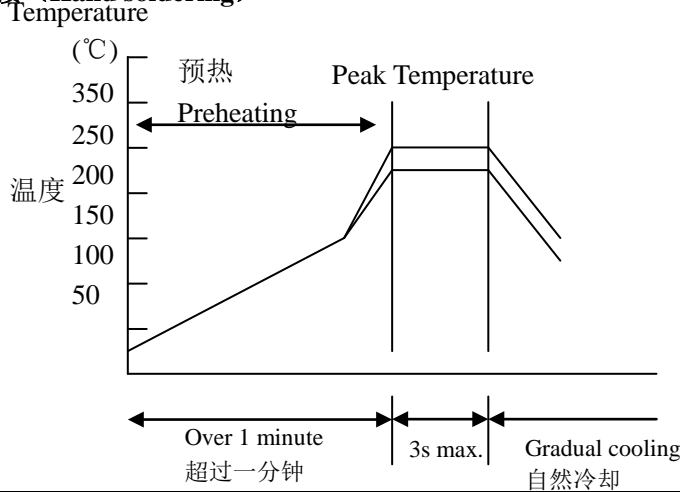

条件 Conditions:

预热 Preheating	烙铁头温度 Temperature of soldering iron head	烙铁功率 Power of soldering iron	烙铁头直径 Diameter of soldering iron head	焊接时间 Soldering time	锡膏量 Solder paste amount	限制条件 Restricted conditions
$\Delta \leq 130^\circ\text{C}$	最高 350°C Highest temperature: 350°C	最大 20W 20W at the highest	建议 1mm 1mm recommended	最长 3s 3s at the longest	$\leq 1/2$ 芯片厚度 $\leq 1/2$ chip thickness	请勿使用烙铁头直接接触陶瓷元件 Please avoid the direct contact between soldering iron head and ceramic components

