

APPROVAL SHEET

MULTILAYER CHIP VARISTOR

For ESD Protection

VH0603 Green Material Series
– RoHS Compliance

*Contents in this sheet are subject to change without prior notice.

DESCRIPTION

Walsin Multilayer Chip Varistor is a family of Transient Voltage Surge Suppression products. Today, electronic circuits are becoming smaller and more sensitive to external interference. Walsin Multilayer Chip Varistor is designed to protect components from destruction of transients and ESD (Electronic Static Discharge). The wide operating voltage and energy range make Walsin Multilayer Chip Varistor suitable for numerous applications on I/O protection, Vcc protection, Keyboard protection, LCD protection, Sensor protection...etc. The Walsin Chip Varistor is manufactured by Multilayer fabrication technology providing excellent voltage clamping ability and is supplied in leadless, surface mount form, compatible with modern reflow and wave soldering procedures.

FEATURES

1. Multilayer fabrication technology
2. -40°C to 125°C operating temperature Range
3. Operating voltage range $V_{M(DC)}$ at $5\text{V} \sim 24\text{V}$
4. Able to withstand ESD test of IEC-61000-4-2
5. Bi-directional clamping characteristic

APPLICATIONS

1. Protection of cellular phones, PDA, High Speed Data Line...etc.
2. ESD Protection for components sensitive to IEC 61000-4-2, Provides Circuit Board Transient Voltage Protection for Transistors.
3. Protection of Video & Audio Ports.

DIMENSIONS

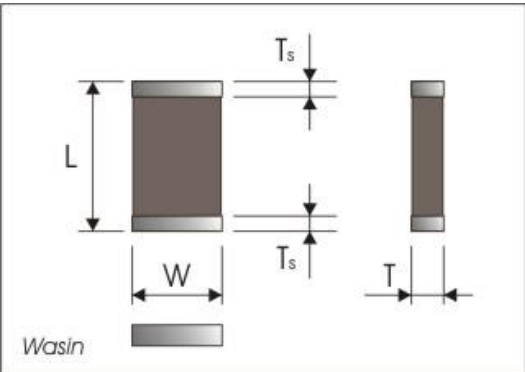
Figure	Symbol	VHZ0603 Series
 <p>The figure shows a top view and a side view of a rectangular chip varistor. The top view labels the length as 'L', the width as 'W', and the thickness as 'T'. The side view labels the thickness of the terminal electrode as 'Ts'. A small 'Walsin' logo is present in the bottom left corner of the drawing area.</p>	L	$1.60 \pm 0.15 \text{ mm}$
	W	$0.80 \pm 0.15 \text{ mm}$
	T	$0.90 \pm 0.15 \text{ mm}$
	Ts	$0.30 \pm 0.20 \text{ mm}$

*Terminal electrode : Ni / Sn electrode

DEVICE RATING AND SPECIFICATIONS

General Vairstor

Part Number	MAXIMUM RATINGS		SPECIFICATIONS			
	Max. Continuous Working Voltage	Max. Clamping Voltage at Specified Current (8/20 μ s)	Nominal Voltage At 1mA (DC) Current		Typical Capacitance @1MHz	
	$V_{M(DC)}$	V_c	$V_{N(DC)Min.}$	$V_{N(DC)Max.}$	C	
	(V)	(V)	(V)	(V)	(pF)	%
VH0603M050CGT100N	5.5	40 at 1A	11	21	10	$\pm 30\%$
VH0603M050CGT330N	5.5	38 at 1A	11	21	33	$\pm 30\%$
VH0603M050CGT470N	5.5	37 at 1A	9	19	47	$\pm 30\%$
VH0603M050CGT101N	5.5	36 at 1A	9	19	100	$\pm 30\%$
VH0603M050CGT331N	5.5	32 at 1A	8	18	330	$\pm 30\%$
VH0603M050CGT102N	5.5	30 at 1A	8	18	1000	$\pm 30\%$
VH0603M120CGT220N	12	46 at 1A	15	25	22	$\pm 30\%$
VH0603M120CGT151N	12	44 at 1A	15	25	150	$\pm 30\%$
VH0603M120CGT331N	12	42 at 1A	15	25	330	$\pm 30\%$

TANDARD TESTING CONDITION

Unless otherwise specified

- Temperature : 15 ~ 35°C
- Humidity : 25%RH ~ 85%RH
- Atmospheric pressure : 86kPa ~ 106kPa

Environment Reliability Test

Characteristic	Test method and description			
High Temperature Storage	The specimen shall be subjected to $125 \pm 2^{\circ}\text{C}$ for 1000 ± 12 hours in a thermostatic bath without load and then stored at room temperature and normal humidity for 1 to 2 hours. The change of varistor voltage shall be within 10 %			
Temperature Cycle	The temperature cycle of specified temperature shall be repeated five times and then stored at room temperature and normal humidity for one or two hours. The change of varistor voltage shall be within 10% and mechanical damage shall be examined.	Step	Temperature	Period
		1	$-40 \pm 3^{\circ}\text{C}$	30Min \pm 3
		2	Room Temperature	1 hour
		3	$125 \pm 3^{\circ}\text{C}$	30Min \pm 3
4	Room Temperature	1 hour		
High Temperature Load	After being continuously applied the maximum allowable voltage at $85 \pm 2^{\circ}\text{C}$ for 1000 ± 2 hours, the specimen shall be stored at room temperature and normal humidity for one or two hours, the change of varistor voltage shall be within 10% .			
Damp Heat Load/ Humidity Load	The specimen should be subjected to $40 \pm 2^{\circ}\text{C}$, 90 to 95 % RH environment, and the maximum allowable voltage applied for 1000 hours, then stored at room temperature and normal humidity for one or two hours. The change of varistor voltage shall be within 10%			
Low Temperature Storage	The specimen should be subjected to $-40 \pm 2^{\circ}\text{C}$, without load for 500 hours and then stored at room temperature for one or two hours. The change of varistor voltage shall be within 10 %			

SOLDERING CONDITION

1. The IP reflow and temperature of Soldering for Pb free

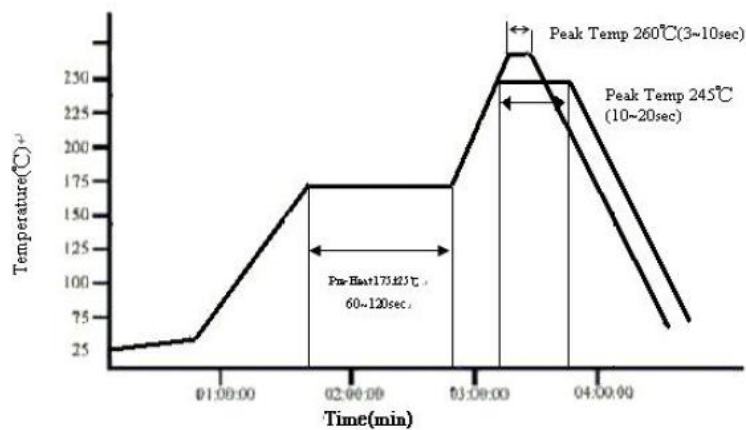

IR reflow Pb Free Process suggestion profile

- (1) The solder recommend is Sn96.5/Ag 3.5 of 120 to 150 μm
- (2) Ramp-up rate (217 $^{\circ}\text{C}$ to Peak) + 3 $^{\circ}\text{C}/\text{second}$ max
- (3) Temp. maintain at 175 \pm 25 $^{\circ}\text{C}$ 180 seconds max
- (4) Temp. maintain above 217 $^{\circ}\text{C}$ 60-150 seconds
- (5) Peak temperature range 245 $^{\circ}\text{C}$ +20 $^{\circ}\text{C}/$ -10 $^{\circ}\text{C}$ time within 5 $^{\circ}\text{C}$ of actually peak temperature (tp) 10~20 seconds
- (6) Ramp down rate +6 $^{\circ}\text{C}/\text{second}$ max

※Perform adequate test in advance as the reflow temperature profile will vary according to the conditions of the manufacturing process, and the specification of the reflow furnace.

2. Resistance to soldering heat-High Temperature Resistance:260°C,10sec-3times.

3. Hand Soldering

In hand soldering of the Varistors. Large temperature gradient between preheated the Varistors and the tip of soldering iron may cause electrical failures and mechanical damages such as crackings or breakings of the devices. The soldering shall be carefully controlled and carried out so that the temperature gradient is kept minimum with following recommended conditions for hand soldering.

3-1 Recommended Soldering Condition 1

(1) Solder :

0.12~0.18mm Thread solder (Sn96.5:Ag3.5) with soldering flux in the core.
Rosin-based and non-activated flux is recommended.

(2) Preheating

The Varistors shall be preheated so that Temperature Gradient between the devices and the tip of soldering iron is 150°C or below.

(3) Soldering Iron

Rated Power of 20w max with 3mm soldering tip in diameter.
Temperature of soldering iron tip 380°C max,3-5sec (The required amount of solder shall be melted in advance on the soldering tip.)

(4) Cooling

After soldering. The Varistors shall be cooled gradually at room ambient temperature.

3-2 Recommended Soldering Condition 2 (Without preheating)

(1) Solder iron tip shall not directly touch to ceramic dielectrics.

(2) Solder iron tip shall be fully preheated before soldering while soldering iron tip to the external electrode of Varistors.

4. Post Soldering Cleaning

4-1 Residues of corrosive soldering fluxes on the PC board after cleaning may greatly have influences on the electrical characteristic and the reliability (such as humidity resistance)of the Varistors which have been mounted on the board. It shall be confirmed that the characteristic and the reliability of the devices are not affected by the applied cleaning conditions.

4-2 When an ultrasonic cleaning is applied to the mounted Varistors on PC Boards. Following conditions are recommended for preventing failures or damages of the devices due to the large vibration energy and the resonance caused by the ultrasonic waves

(1)Frequency 29MHz max

(2)Radiated Power 20w/lithr max

(3)Period 5minuets max

ORDERING CODE

General Vairstor

VH	0603	M	050	C	G	T	100	
Type Code	Chip Size	Style	Rated Voltage	Capacitance Tolerance	Termination	Packing	Capacitance Code (pF)	Internal Code
V: Walsin Varistor H: High Speed or RF	0603	M: Multilayer A: Array	050 = 5.5V 120 = 12V 240 = 24V	C: Capacitance control code for ESD protection varistor	G: Green Material	T: Reeled B: Bulk	Two significant digits followed by number of zeros 5R0 = 5pF (when C< 10pF) 100 = 10 x 10 ⁰ = 15pF 220 = 22 x 10 ⁰ = 22pF 330 = 33 x 10 ⁰ = 33pF 101 = 10 x 10 ¹ = 100pF	Blank: None N: New item

PACKAGING

Paper Tape specifications (unit :mm) and Packaging quantity

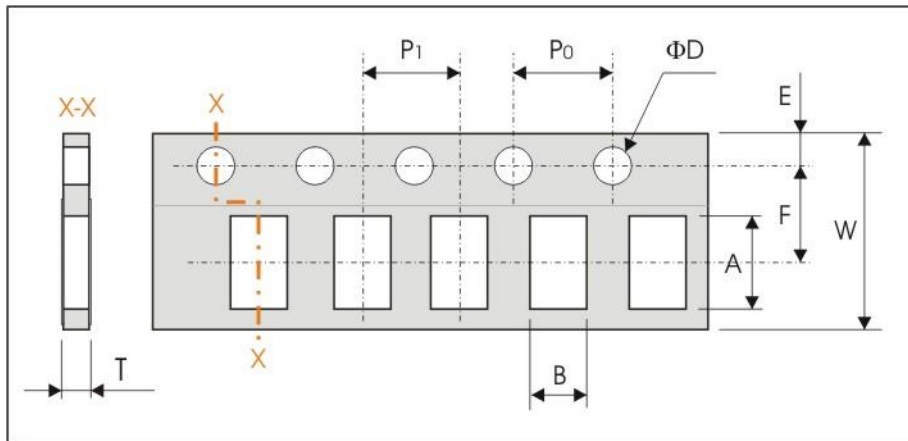

Label	A	B	E	F	ΦD
VZ0603 Series	1.90 ± 0.05	1.10 ± 0.05	1.75 ± 0.05	3.50 ± 0.05	1.56 ± 0.05

Label	P0	P1	T	W	Quantity/Reel
VZ0603 Series	4.00 ± 0.10	2.00 ± 0.10	0.95 ± 0.05	8.00 ± 0.10	4Kpcs

- Tape Material : Paper tape.

Reel dimensions

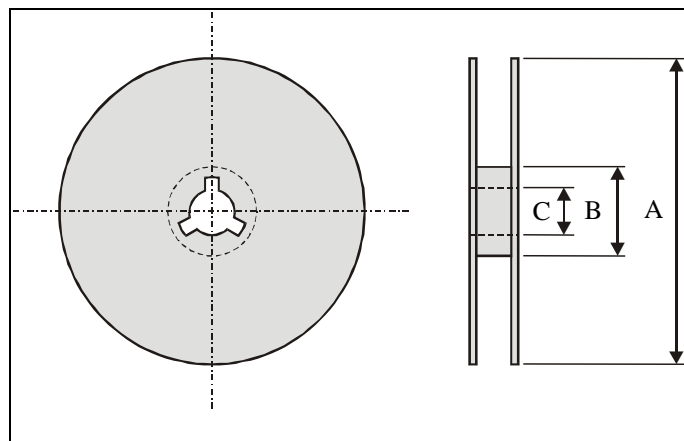

Index	A	B	C
Dimension (mm)	Φ178± 1.0	Φ60.0± 0.5	Φ13.0± 0.2

CAUTION OF HANDLING

Limitation of Applications

Please contact us before using our products for the applications listed below which require especially high reliability for the prevention of defects, which might directly cause damage to the third party's life, body or property.

- (1) Aircraft equipment
- (2) Aerospace equipment
- (3) Undersea equipment
- (4) Medical equipment
- (5) Traffic signal equipment
- (6) Applications of similar complexity and /or reliability requirements to the applications listed in the above.

Storage condition

- (1) Products should be used in 6 months from the day of WALSIN outgoing inspection, which can be confirmed.
- (2) Storage environment condition.
 - Products should be storage in the warehouse on the following conditions.
 - Temperature : -10 to +40°C
 - Humidity : 30 to 70% relative humidity
 - Don't keep products in corrosive gases such as sulfur. Chlorine gas or acid or it may cause oxidization of electrode, resulting in poor solderability.
 - Products should be storage on the palette for the prevention of the influence from humidity, dust and son on.
 - Products should be storage in the warehouse without heat shock, vibration, direct sunlight and so on.
 - Products should be storage under the airtight packaged condition.