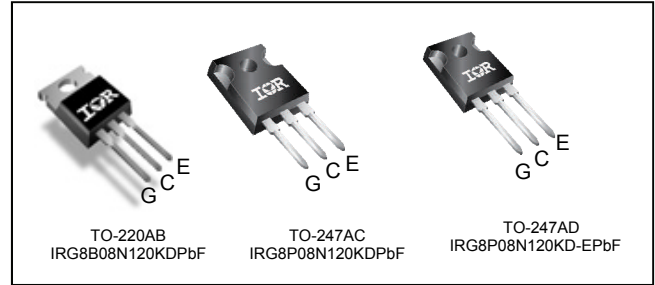
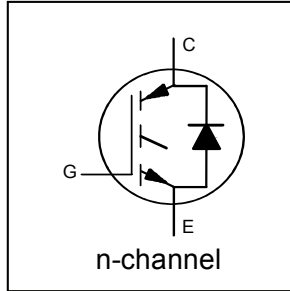


**Insulated Gate Bipolar Transistor with Ultrafast Soft Recovery Diode**

$V_{CES} = 1200V$
$I_C = 8A, T_C = 100^\circ C$
$t_{SC} \geq 10\mu s, T_{J(max)} = 150^\circ C$
$V_{CE(ON)} \text{ typ.} = 1.7V @ I_C = 5A$



G	C	E
Gate	Collector	Emitter

**Applications**

- Industrial Motor Drive
- UPS
- Solar Inverters
- Welding

Features	Benefits
Benchmark Low $V_{CE(ON)}$	High Efficiency in a Motor Drive Applications
10 $\mu s$ Short Circuit SOA	Increases margin for short circuit protection scheme
Positive $V_{CE(ON)}$ Temperature Coefficient	Excellent Current Sharing in Parallel Operation
Square RBSOA and high $I_{LM}$ rating	Rugged Transient Performance
Lead-Free, RoHS compliant	Environmentally friendly

Base part number	Package Type	Standard Pack		Orderable Part Number
		Form	Quantity	
IRG8P08N120KDPbF	TO-247AC	Tube	25	IRG8P08N120KDPbF
IRG8P08N120KD-EPbF	TO-247AD	Tube	25	IRG8P08N120KD-EPbF
IRG8B08N120KDPbF	TO-220AB	Tube	50	IRG8B08N120KDPbF

**Absolute Maximum Ratings**

	Parameter	Max.	Units
$V_{CES}$	Collector-to-Emitter Voltage	1200	V
$I_C @ T_C = 25^\circ C$	Continuous Collector Current (Silicon Limited)	15	A
$I_C @ T_C = 100^\circ C$	Continuous Collector Current	8	
$I_{CM}$	Pulse Collector Current (see fig. 2)	15	
$I_{LM}$	Clamped Inductive Load Current (see fig. 3)①	20	
$I_F @ T_C = 25^\circ C$	Diode Continuous Forward Current	11	
$I_F @ T_C = 100^\circ C$	Diode Continuous Forward Current	6	V
$V_{GE}$	Continuous Gate-to-Emitter Voltage	$\pm 30$	
$I_{FM}$	Diode Maximum Forward Current ⑤	20	W
$P_D @ T_C = 25^\circ C$	Maximum Power Dissipation	89	
$P_D @ T_C = 100^\circ C$	Maximum Power Dissipation	36	
$T_J$	Operating Junction and	-40 to +150	C
$T_{STG}$	Storage Temperature Range		
	Soldering Temperature, for 10 sec.	300 (0.063 in. (1.6mm) from case)	
	Mounting Torque, 6-32 or M3 Screw	10 lbf-in (1.1 N-m)	

**Thermal Resistance**

	Parameter	Typ.	Max.	Units
$R_{\theta JC}$ (IGBT)	Thermal Resistance Junction-to-Case-(each IGBT) @TO-220AB	—	1.3	°C/W
$R_{\theta JC}$ (Diode)	Thermal Resistance Junction-to-Case-(each Diode) @TO-220AB	—	2.6	
$R_{\theta JC}$ (IGBT)	Thermal Resistance Junction-to-Case-(each IGBT) @TO-247	—	1.4	
$R_{\theta JC}$ (Diode)	Thermal Resistance Junction-to-Case-(each Diode) @TO-247	—	2.6	
$R_{\theta CS}$	Thermal Resistance, Case-to-Sink (flat, greased surface)TO-220AB	0.50	—	
$R_{\theta JA}$	Thermal Resistance, Junction-to-Ambient (typical socket mount)TO-220AB	—	62	
$R_{\theta CS}$	Thermal Resistance, Case-to-Sink (flat, greased surface)TO-247	0.24	—	
$R_{\theta JA}$	Thermal Resistance, Junction-to-Ambient (typical socket mount)TO-247	—	40	

**Electrical Characteristics @ T<sub>J</sub> = 25°C (unless otherwise specified)**

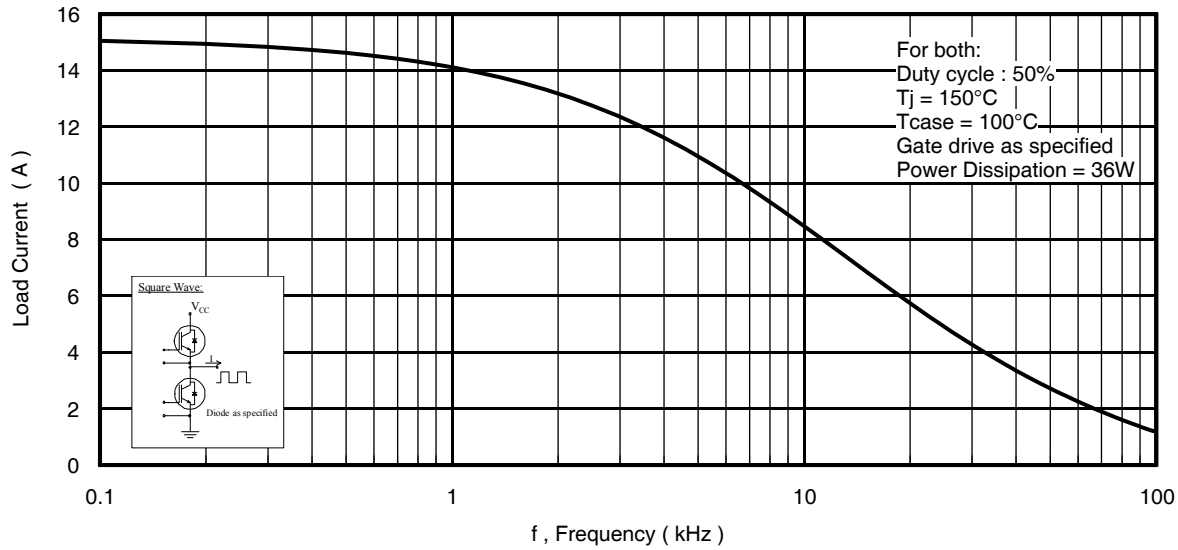
	Parameter	Min.	Typ.	Max.	Units	Conditions
V <sub>(BR)CES</sub>	Collector-to-Emitter Breakdown Voltage	1200	—	—	V	V <sub>GE</sub> = 0V, I <sub>C</sub> = 250μA ③
ΔV <sub>(BR)CES</sub> /ΔT <sub>J</sub>	Temperature Coeff. of Breakdown Voltage	—	1.2	—	V/°C	V <sub>GE</sub> = 0V, I <sub>C</sub> = 1mA (25°C-150°C)
V <sub>CE(on)</sub>	Collector-to-Emitter Saturation Voltage	—	1.7	2.0	V	I <sub>C</sub> = 5A, V <sub>GE</sub> = 15V, T <sub>J</sub> = 25°C
		—	2.1	—		I <sub>C</sub> = 5A, V <sub>GE</sub> = 15V, T <sub>J</sub> = 150°C
V <sub>GE(th)</sub>	Gate Threshold Voltage	5.0	—	6.5	V	V <sub>CE</sub> = V <sub>GE</sub> , I <sub>C</sub> = 200μA
ΔV <sub>GE(th)</sub> /ΔT <sub>J</sub>	Threshold Voltage Temperature Coeff.	—	-14	—	mV/°C	V <sub>CE</sub> = V <sub>GE</sub> , I <sub>C</sub> = 200μA(25°C-150°C)
g <sub>fe</sub>	Forward Transconductance	—	2.9	—	S	V <sub>CE</sub> = 50V, I <sub>C</sub> = 5A, PW = 20μs
I <sub>CES</sub>	Collector-to-Emitter Leakage Current	—	1.0	35	μA	V <sub>GE</sub> = 0V, V <sub>CE</sub> = 1200V
		—	1.0	—	mA	V <sub>GE</sub> = 0V, V <sub>CE</sub> = 1200V, T <sub>J</sub> = 150°C
I <sub>GES</sub>	Gate-to-Emitter Leakage Current	—	—	±100	nA	V <sub>GE</sub> = ±30V
V <sub>F</sub>	Diode Forward Voltage Drop	—	2.3	2.7	V	I <sub>F</sub> = 5A
		—	2.5	—		I <sub>F</sub> = 5A, T <sub>J</sub> = 150°C

**Switching Characteristics @ T<sub>J</sub> = 25°C (unless otherwise specified)**

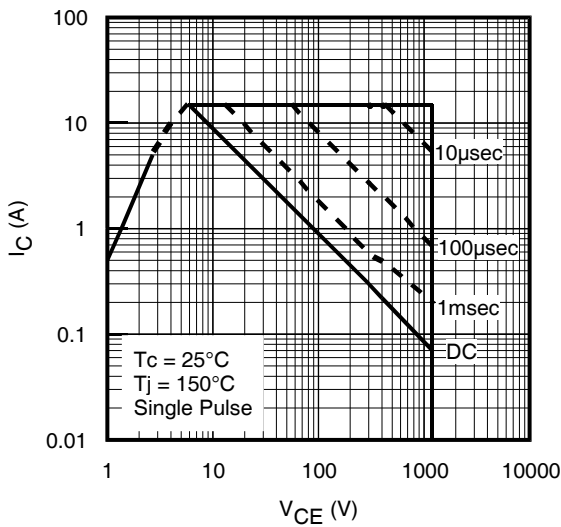
	Parameter	Min.	Typ.	Max④	Units	Conditions
Q <sub>g</sub>	Total Gate Charge (turn-on)	—	30	45	nC	I <sub>C</sub> = 5A
Q <sub>ge</sub>	Gate-to-Emitter Charge (turn-on)	—	1.1	1.7		V <sub>GE</sub> = 15V
Q <sub>gc</sub>	Gate-to-Collector Charge (turn-on)	—	20	—		V <sub>CC</sub> = 600V
E <sub>on</sub>	Turn-On Switching Loss	—	0.3	—	mJ	I <sub>C</sub> = 5A, V <sub>CC</sub> = 600V, V <sub>GE</sub> = 15V R <sub>G</sub> = 47Ω, T <sub>J</sub> = 25°C Energy losses include tail & diode reverse recovery ⑥
E <sub>off</sub>	Turn-Off Switching Loss	—	0.3	—		
E <sub>total</sub>	Total Switching Loss	—	0.6	—		
t <sub>d(on)</sub>	Turn-On delay time	—	20	—	ns	
t <sub>r</sub>	Rise time	—	20	—		
t <sub>d(off)</sub>	Turn-Off delay time	—	160	—		
t <sub>f</sub>	Fall time	—	240	—		
E <sub>on</sub>	Turn-On Switching Loss	—	0.5	—	mJ	I <sub>C</sub> = 5A, V <sub>CC</sub> = 600V, V <sub>GE</sub> = 15V R <sub>G</sub> = 47Ω, T <sub>J</sub> = 150°C Energy losses include tail & diode reverse recovery ⑥
E <sub>off</sub>	Turn-Off Switching Loss	—	0.5	—		
E <sub>total</sub>	Total Switching Loss	—	1.0	—		
t <sub>d(on)</sub>	Turn-On delay time	—	20	—	ns	
t <sub>r</sub>	Rise time	—	20	—		
t <sub>d(off)</sub>	Turn-Off delay time	—	300	—		
t <sub>f</sub>	Fall time	—	290	—		
C <sub>ies</sub>	Input Capacitance	—	720	—	pF	V <sub>GE</sub> = 0V
C <sub>oes</sub>	Output Capacitance	—	30	—		V <sub>CC</sub> = 30V
C <sub>res</sub>	Reverse Transfer Capacitance	—	15	—		f = 1.0Mhz
RBSOA	Reverse Bias Safe Operating Area	FULL SQUARE				T <sub>J</sub> = 150°C, I <sub>C</sub> = 20A V <sub>CC</sub> = 960V, V <sub>p</sub> ≤ 1200V V <sub>GE</sub> = +20V to 0V
SCSOA	Short Circuit Safe Operating Area	10	—	—	μs	T <sub>J</sub> = 150°C, V <sub>CC</sub> = 600V, V <sub>p</sub> ≤ 1200V V <sub>GE</sub> = +15V to 0V
E <sub>rec</sub>	Reverse Recovery Energy of the Diode	—	240	—	μJ	T <sub>J</sub> = 150°C
t <sub>rr</sub>	Diode Reverse Recovery Time	—	50	—	ns	V <sub>CC</sub> = 600V, I <sub>F</sub> = 5A
I <sub>rr</sub>	Peak Reverse Recovery Current	—	11	—	A	V <sub>GE</sub> = 15V, R <sub>G</sub> = 47Ω

**Notes:**

- ① V<sub>CC</sub> = 80% (V<sub>CES</sub>), V<sub>GE</sub> = 20V.
- ② R<sub>θ</sub> is measured at T<sub>J</sub> of approximately 90°C.
- ③ Refer to AN-1086 for guidelines for measuring V<sub>(BR)CES</sub> safely.
- ④ Maximum limits are based on statistical sample size characterization.
- ⑤ Pulse width limited by max. junction temperature.
- ⑥ Values influenced by parasitic L and C in measurement.

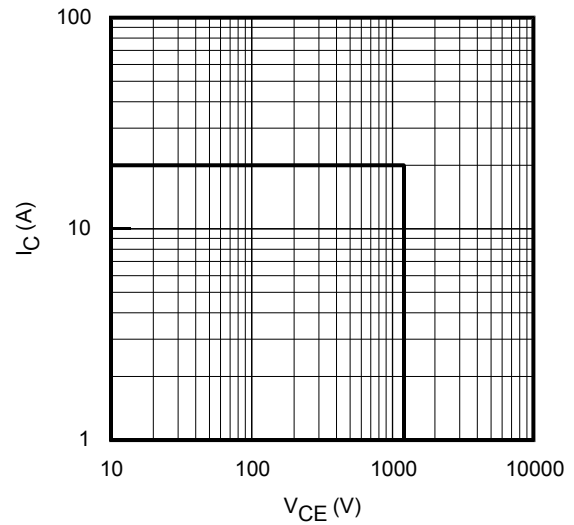


**Fig. 1 - Typical Load Current vs. Frequency**  
(Load Current = IRMS of fundamental)



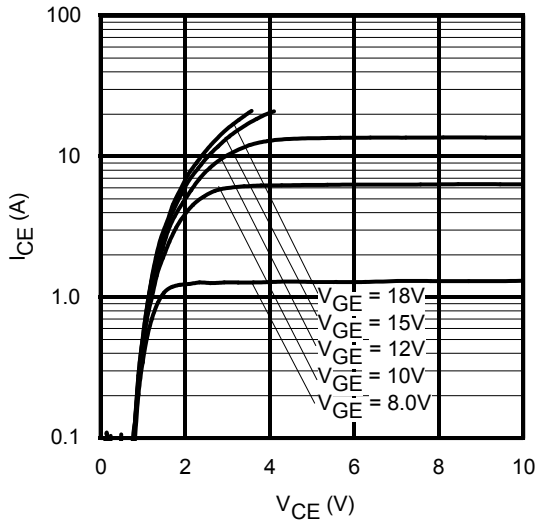
**Fig. 2 - Forward SOA**

$T_C = 25^\circ\text{C}; T_J \leq 150^\circ\text{C}; V_{GE} = 15\text{V}$

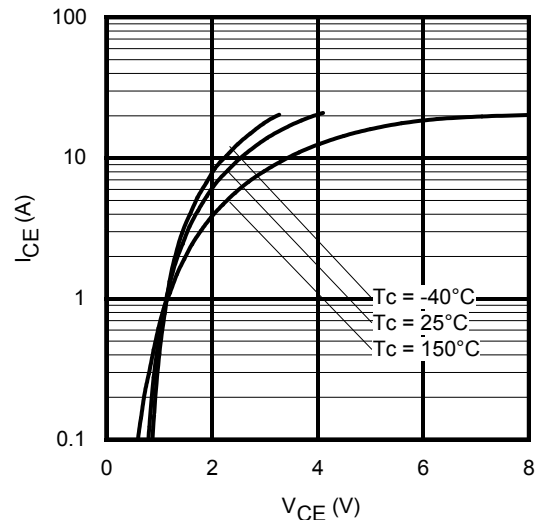


**Fig. 3 - Reverse Bias SOA**

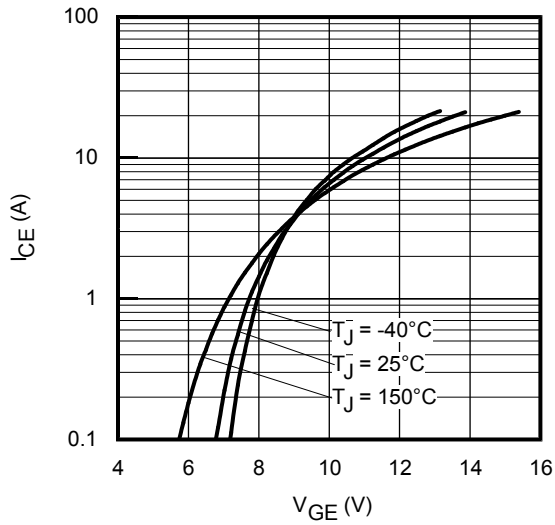
$T_J = 150^\circ\text{C}; V_{GE} = 20\text{V}$



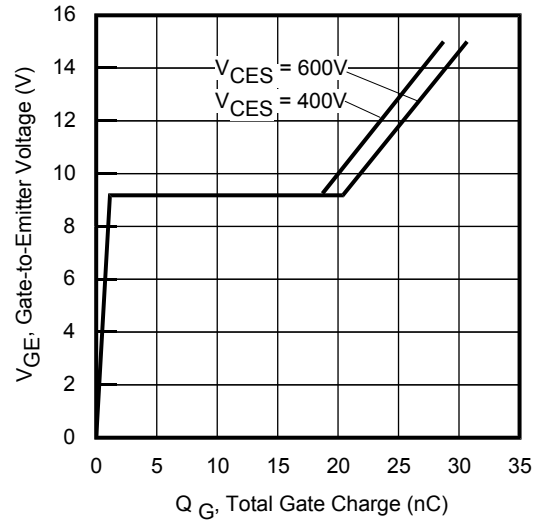
**Fig. 4 - Typ. IGBT Output Characteristics**  
 $T_J = 25^\circ\text{C}; t_p = 20\mu\text{s}$



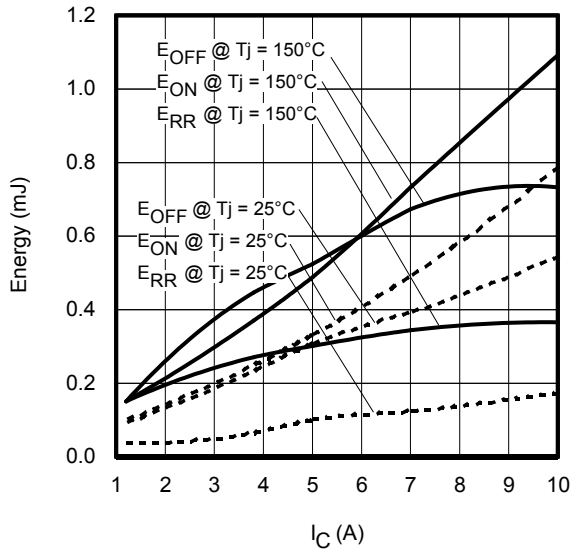
**Fig. 5 - Typ. IGBT Saturation Voltage**  
 $V_{GE} = 15\text{V}; t_p = 20\mu\text{s}$



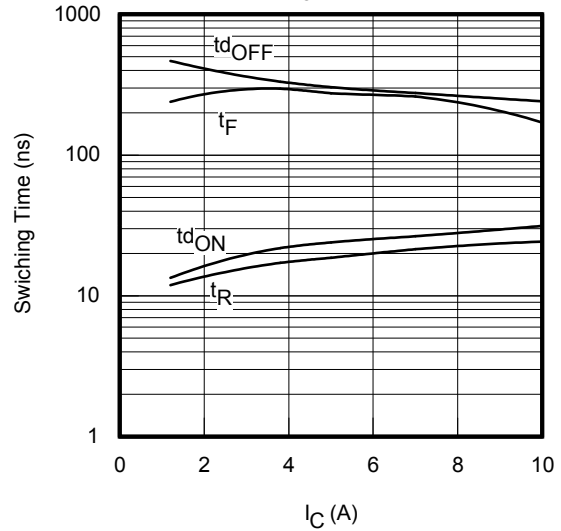
**Fig. 6 - Typ. Transfer Characteristics**  
 $V_{CE} = 50V$ ;  $t_p = 20\mu s$



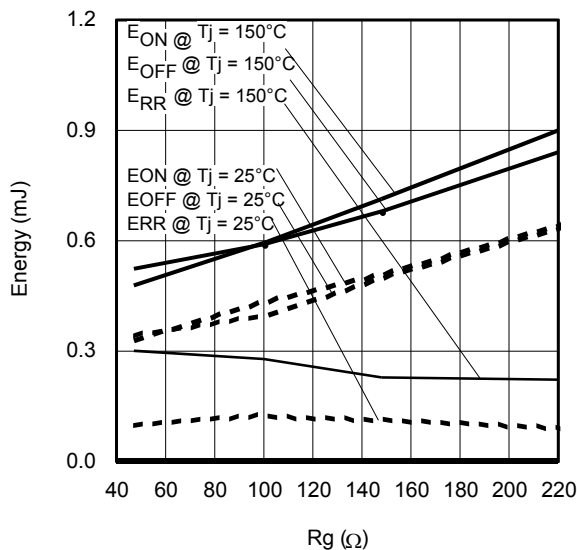
**Fig. 7 - Typical Gate Charge vs.  $V_{GE}$**   
 $I_{CE} = 5A$



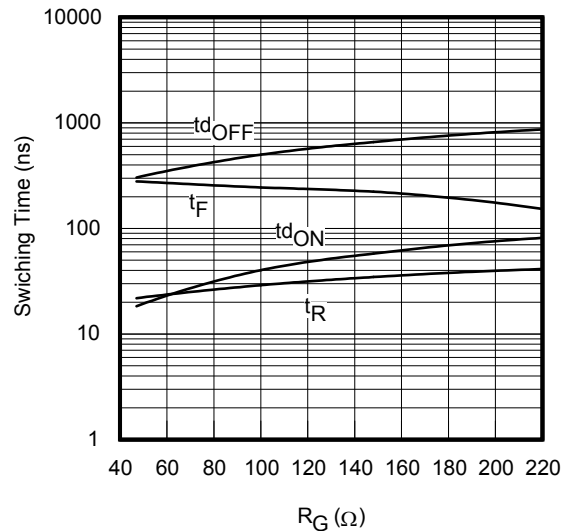
**Fig. 8 - Typ. Energy Loss vs.  $I_C$**   
 $V_{CE} = 600V$ ,  $R_G = 47\Omega$ ;  $V_{GE} = 15V$



**Fig. 9 - Typ. Switching Time vs.  $I_C$**   
 $T_J = 150^\circ C$ ;  $V_{CE} = 600V$ ,  $R_G = 47\Omega$ ;  $V_{GE} = 15V$



**Fig. 10 - Typ. Energy Loss vs.  $R_G$**   
 $V_{CE} = 600V$ ,  $I_{CE} = 5A$ ;  $V_{GE} = 15V$



**Fig. 11 - Typ. Switching Time vs.  $R_G$**   
 $T_J = 150^\circ C$ ;  $V_{CE} = 600V$ ,  $I_{CE} = 5A$ ;  $V_{GE} = 15V$

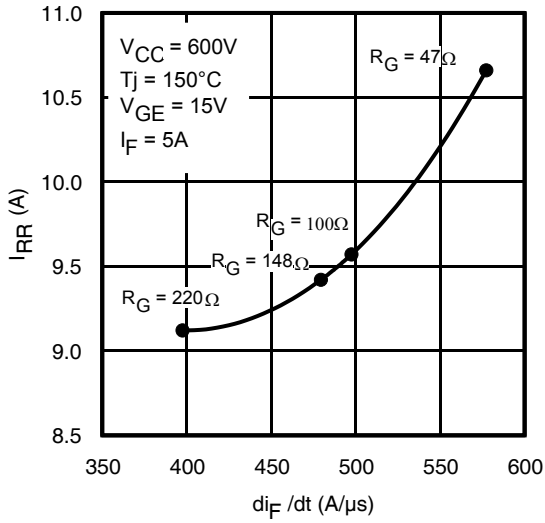


Fig. 12 - Fig. 12 - Typ.  $I_{RR}$  vs.  $di/dt$

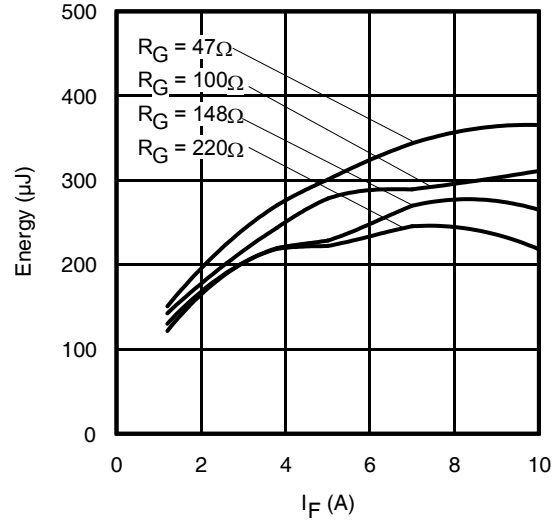


Fig. 13 - Typ. Diode  $E_{RR}$  vs.  $I_F$   
 $T_J = 150^\circ C$

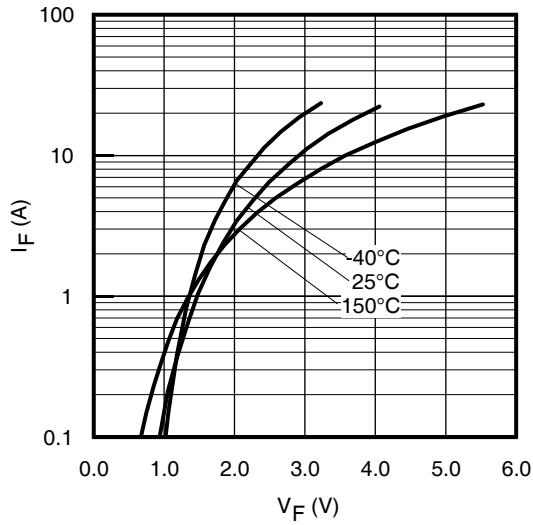


Fig. 14 - Typ. Diode Forward Voltage Drop Characteristics

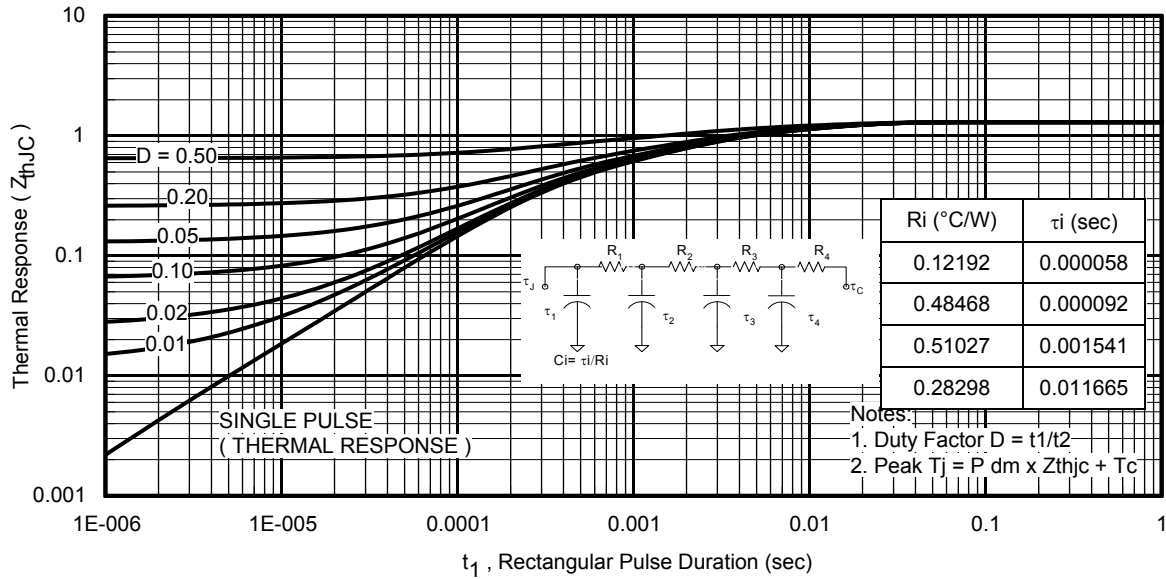


Fig. 15 - Maximum Transient Thermal Impedance, Junction-to-Case (IGBT) TO-247

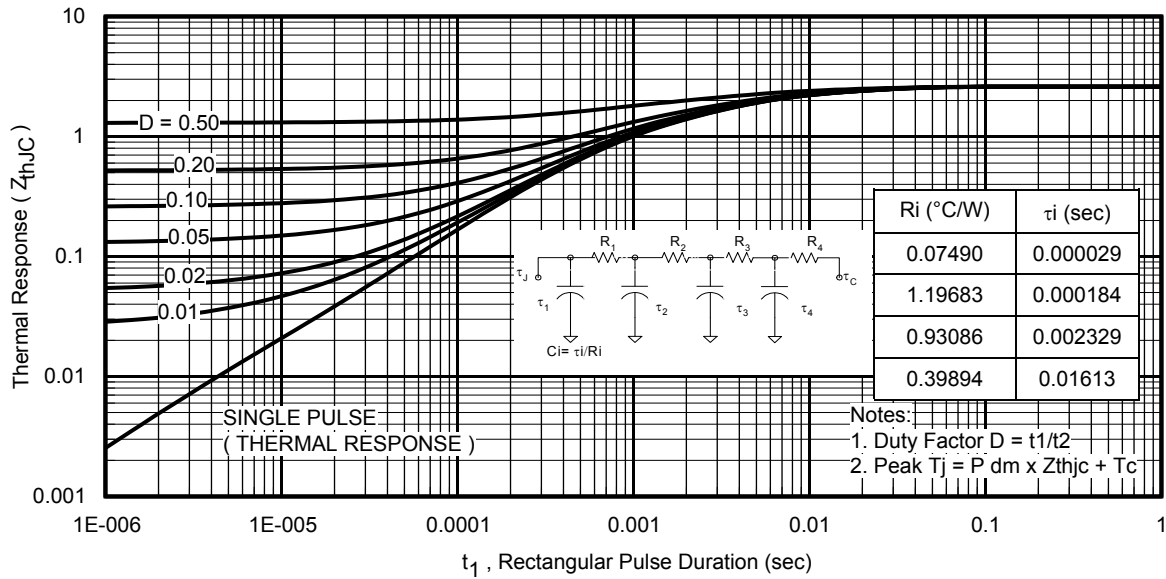


Fig. 16 - Maximum Transient Thermal Impedance, Junction-to-Case (DIODE) TO-247

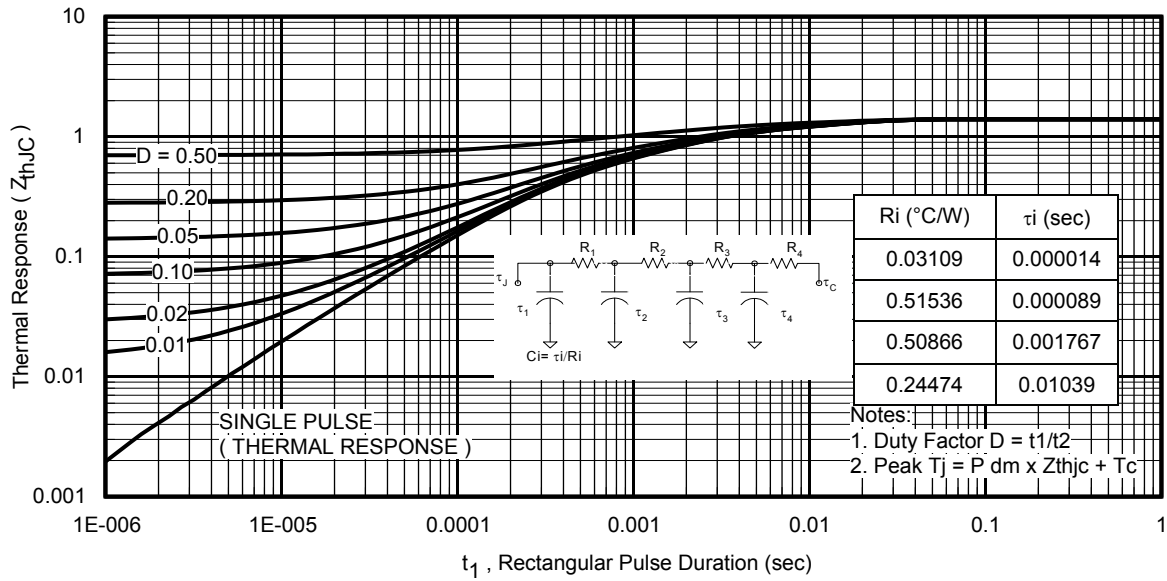


Fig. 17 - Maximum Transient Thermal Impedance, Junction-to-Case (IGBT) TO-220AB

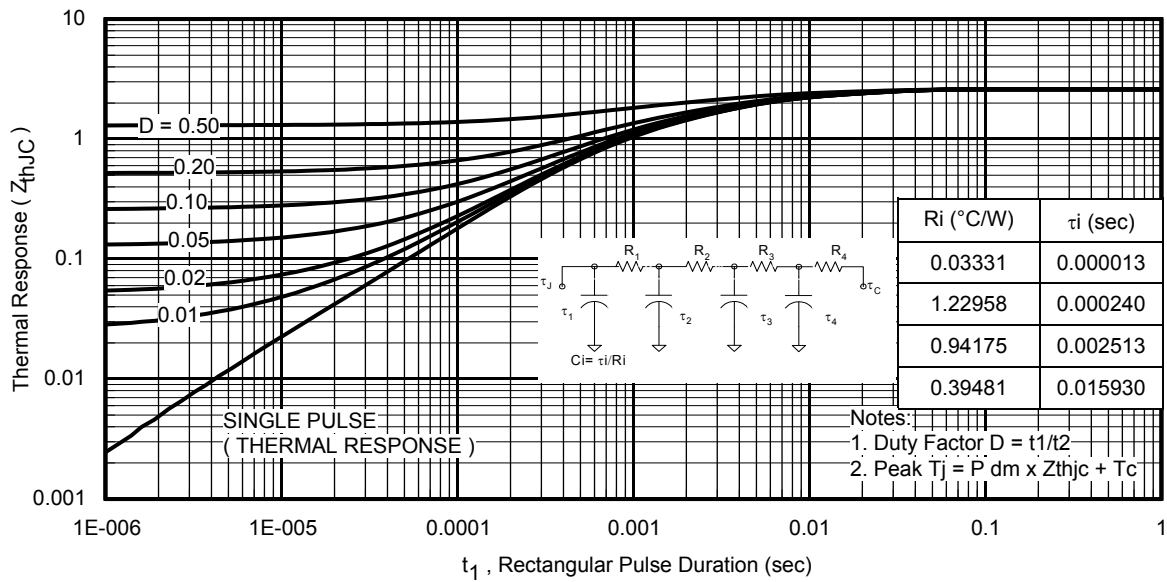
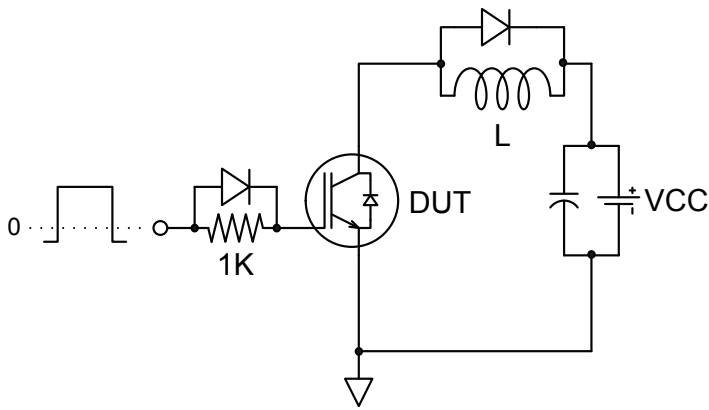
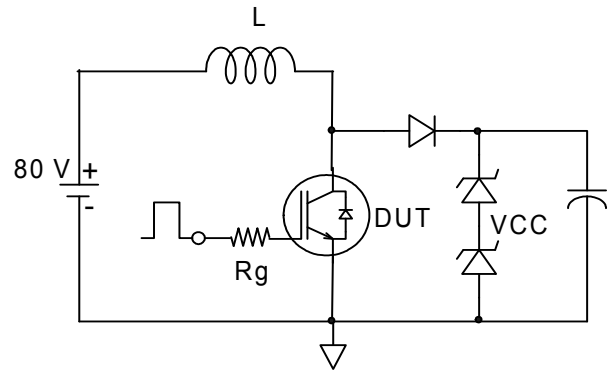
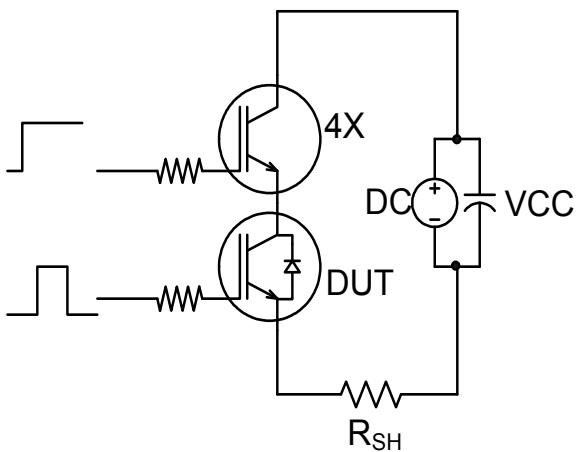
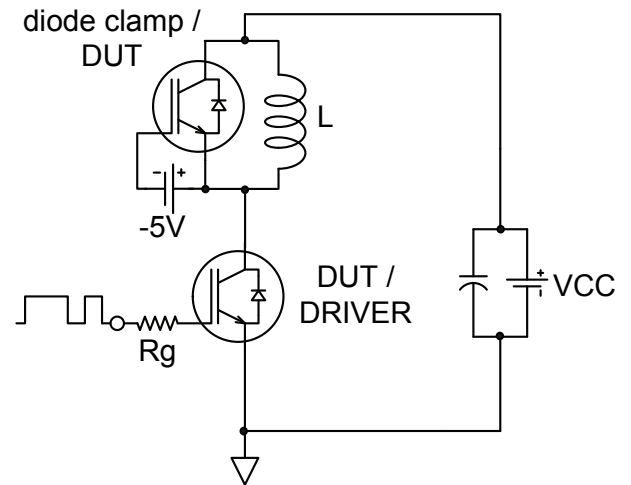
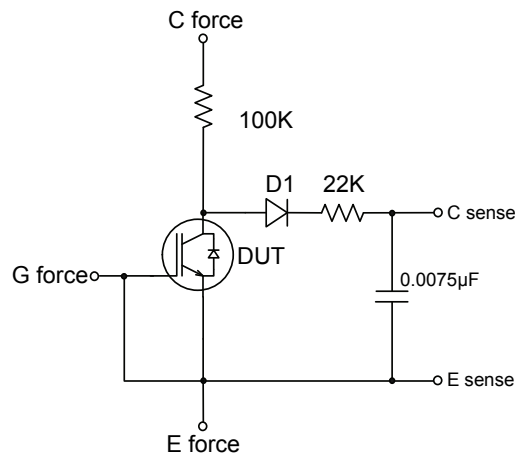
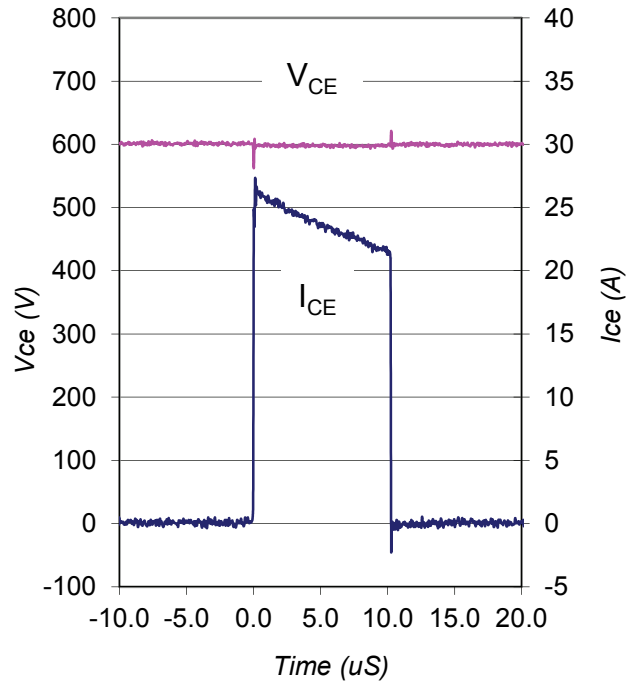


Fig. 18 - Maximum Transient Thermal Impedance, Junction-to-Case (DIODE) TO-220AB

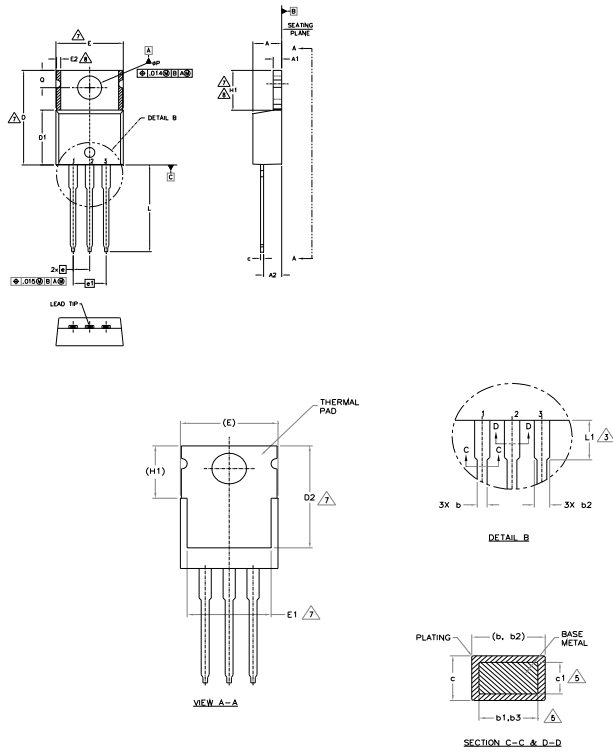

**Fig.C.T.1 - Gate Charge Circuit (turn-off)**

**Fig.C.T.2 - RBSOA Circuit**

**Fig.C.T.3 - S.C. SOA Circuit**

**Fig.C.T.4 - Switching Loss Circuit  
(Board Stray Inductance 180nH)**

**Fig.C.T.5 - BVCES Filter Circuit**





**Fig. WF1** - Typ. S.C. Waveform  
 @  $T_J = 150^\circ\text{C}$  using Fig. CT.3

**TO-220AB Package Outline (Dimensions are shown in millimeters (inches))**



**NOTES:**

- 1.- DIMENSIONING AND TOLERANCING AS PER ASME Y14.5 M- 1994.
- 2.- DIMENSIONS ARE SHOWN IN INCHES [MILLIMETERS].
- 3.- LEAD DIMENSION AND FINISH UNCONTROLLED IN L1.
- 4.- DIMENSION D, D1 & E DO NOT INCLUDE MOLD FLASH. MOLD FLASH SHALL NOT EXCEED .005" (0.127) PER SIDE. THESE DIMENSIONS ARE MEASURED AT THE OUTERMOST EXTREMES OF THE PLASTIC BODY.
- 5.- DIMENSION b1, b3 & c1 APPLY TO BASE METAL ONLY.
- 6.- CONTROLLING DIMENSION : INCHES.
- 7.- THERMAL PAD CONTOUR OPTIONAL WITHIN DIMENSIONS E,H1,D2 & E1
- 8.- DIMENSION E2 X H1 DEFINE A ZONE WHERE STAMPING AND SINGULATION IRREGULARITIES ARE ALLOWED.
- 9.- OUTLINE CONFORMS TO JEDEC TO-220, EXCEPT A2 (max.) AND D2 (min.) WHERE DIMENSIONS ARE DERIVED FROM THE ACTUAL PACKAGE OUTLINE.

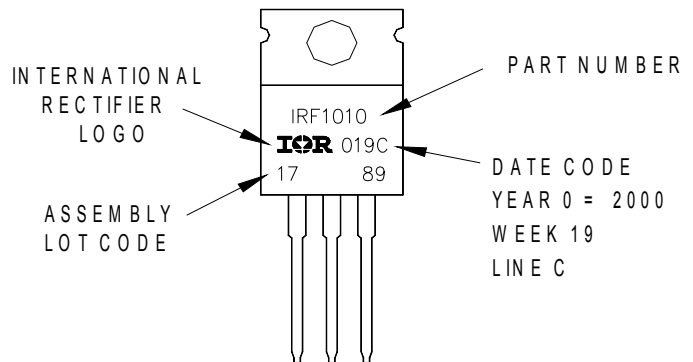
SYMBOL	DIMENSIONS				NOTES
	MILLIMETERS		INCHES		
	MIN.	MAX.	MIN.	MAX.	
A	3.56	4.83	.140	.190	
A1	0.51	1.40	.020	.055	
A2	2.03	2.92	.080	.115	
b	0.38	1.01	.015	.040	
b1	0.38	0.97	.015	.038	5
b2	1.14	1.78	.045	.070	
b3	1.14	1.73	.045	.068	5
c	0.36	0.61	.014	.024	
c1	0.36	0.56	.014	.022	5
D	14.22	16.51	.560	.650	4
D1	8.38	9.02	.330	.355	
D2	11.68	12.88	.460	.507	7
E	9.65	10.67	.380	.420	4,7
E1	6.86	8.89	.270	.350	7
E2	-	0.76	-	.030	8
e	2.54 BSC		.100 BSC		
e1	5.08 BSC		.200 BSC		
H1	5.84	6.86	.230	.270	7,8
L	12.70	14.73	.500	.580	
L1	3.56	4.06	.140	.160	3
øP	3.54	4.08	.139	.161	
Q	2.54	3.42	.100	.135	

- LEAD ASSIGNMENTS**
- HEXFET**
- 1.- GATE
  - 2.- DRAIN
  - 3.- SOURCE
- IGBTs, CoPACK**
- 1.- GATE
  - 2.- COLLECTOR
  - 3.- EMITTER
- DIODES**
- 1.- ANODE
  - 2.- CATHODE
  - 3.- ANODE

**TO-220AB Part Marking Information**

EXAMPLE: THIS IS AN IRF1010  
 LOT CODE 1789  
 ASSEMBLED ON WW 19, 2000  
 IN THE ASSEMBLY LINE "C"

Note: "P" in assembly line position indicates "Lead - Free"

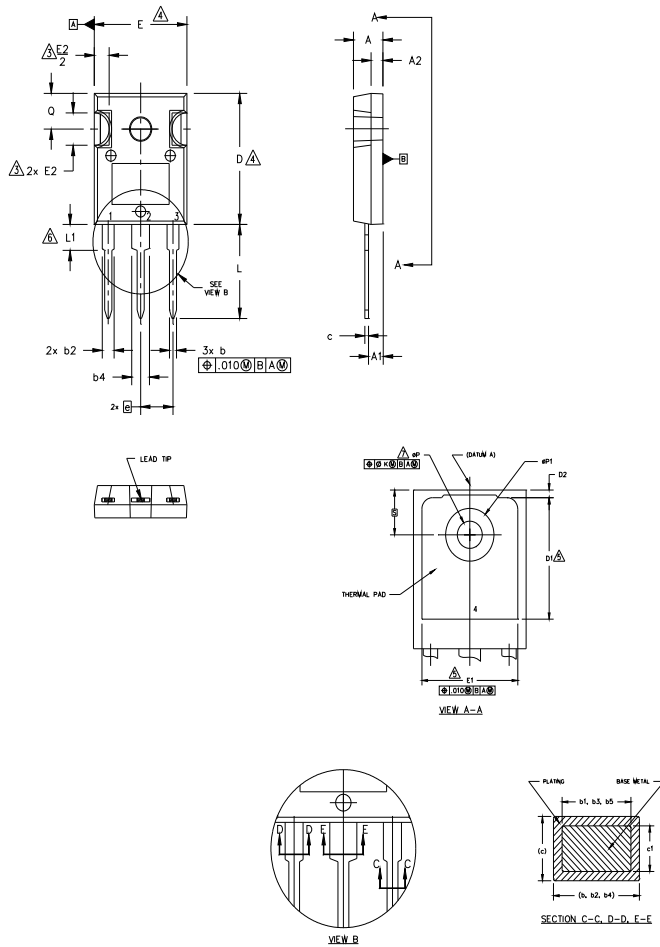


TO-220AB packages are not recommended for Surface Mount Application.

Note: For the most current drawing please refer to IR website at <http://www.irf.com/package/>

# TO-247AC Package Outline

Dimensions are shown in millimeters (inches)



NOTES:

1. DIMENSIONING AND TOLERANCING AS PER ASME Y14.5M 1994.
2. DIMENSIONS ARE SHOWN IN INCHES.
3. CONTOUR OF SLOT OPTIONAL.
4. DIMENSION D & E DO NOT INCLUDE MOLD FLASH. MOLD FLASH SHALL NOT EXCEED .005" (0.127) PER SIDE. THESE DIMENSIONS ARE MEASURED AT THE OUTERMOST EXTREMES OF THE PLASTIC BODY.
5. THERMAL PAD CONTOUR OPTIONAL WITHIN DIMENSIONS D1 & E1.
6. LEAD FINISH UNCONTROLLED IN L1.
7. ØP TO HAVE A MAXIMUM DRAFT ANGLE OF 1.5 ° TO THE TOP OF THE PART WITH A MAXIMUM HOLE DIAMETER OF .154 INCH.
8. OUTLINE CONFORMS TO JEDEC OUTLINE TO-247AC .

SYMBOL	DIMENSIONS				NOTES
	INCHES		MILLIMETERS		
	MIN.	MAX.	MIN.	MAX.	
A	.183	.209	4.65	5.31	
A1	.087	.102	2.21	2.59	
A2	.059	.098	1.50	2.49	
b	.039	.055	0.99	1.40	
b1	.039	.053	0.99	1.35	
b2	.065	.094	1.65	2.39	
b3	.065	.092	1.65	2.34	
b4	.102	.135	2.59	3.43	
b5	.102	.133	2.59	3.38	
c	.015	.035	0.38	0.89	
c1	.015	.033	0.38	0.84	
D	.776	.815	19.71	20.70	4
D1	.515	-	13.08	-	5
D2	.020	.053	0.51	1.35	
E	.602	.625	15.29	15.87	4
E1	.530	-	13.46	-	
E2	.178	.216	4.52	5.49	
e	.215 BSC		5.46 BSC		
Øk	.010		0.25		
L	.559	.634	14.20	16.10	
L1	.146	.169	3.71	4.29	
ØP	.140	.144	3.56	3.66	
ØP1	-	.291	-	7.39	
Q	.209	.224	5.31	5.69	
S	.217 BSC		5.51 BSC		

LEAD ASSIGNMENTS

HEXFET

- 1.- GATE
- 2.- DRAIN
- 3.- SOURCE
- 4.- DRAIN

IGBTs, CoPACK

- 1.- GATE
- 2.- COLLECTOR
- 3.- EMITTER
- 4.- COLLECTOR

DIODES

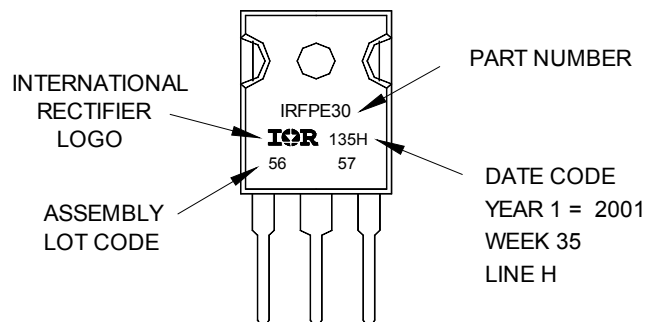
- 1.- ANODE/OPEN
- 2.- CATHODE
- 3.- ANODE

# TO-247AC Part Marking Information

Notes: This part marking information applies to devices produced after 02/26/2001

EXAMPLE: THIS IS AN IRFPE30 WITH ASSEMBLY LOT CODE 5657 ASSEMBLED ON WW 35, 2001 IN THE ASSEMBLY LINE "H"

Note: "P" in assembly line position indicates "Lead-Free"

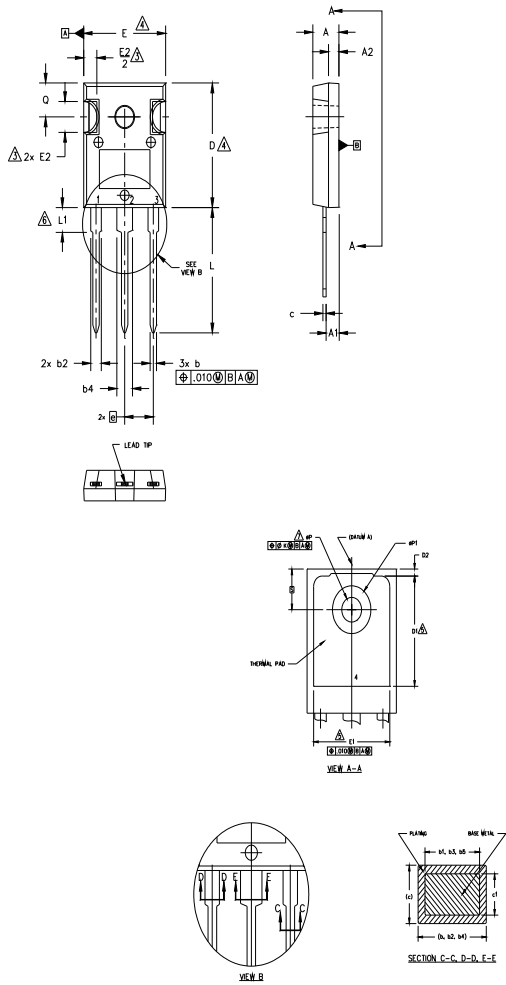


TO-247AC package is not recommended for Surface Mount Application.

Note: For the most current drawing please refer to IR website at <http://www.irf.com/package/>

# TO-247AD Package Outline

Dimensions are shown in millimeters (inches)



**NOTES:**

1. DIMENSIONING AND TOLERANCING AS PER ASME Y14.5M 1994.
2. DIMENSIONS ARE SHOWN IN INCHES.
3. CONTOUR OF SLOT OPTIONAL.
4. DIMENSION D & E DO NOT INCLUDE MOLD FLASH. MOLD FLASH SHALL NOT EXCEED .005" (0.127) PER SIDE. THESE DIMENSIONS ARE MEASURED AT THE OUTERMOST EXTREMES OF THE PLASTIC BODY.
5. THERMAL PAD CONTOUR OPTIONAL WITHIN DIMENSIONS D1 & E1.
6. LEAD FINISH UNCONTROLLED IN L1.
7. ØP TO HAVE A MAXIMUM DRAFT ANGLE OF 1.5 ° TO THE TOP OF THE PART WITH A MAXIMUM HOLE DIAMETER OF .154 INCH.
8. OUTLINE CONFORMS TO JEDEC OUTLINE TO-247AD.

SYMBOL	DIMENSIONS				NOTES
	INCHES		MILLIMETERS		
	MIN.	MAX.	MIN.	MAX.	
A	.183	.209	4.65	5.31	
A1	.087	.102	2.21	2.59	
A2	.059	.098	1.50	2.49	
b	.039	.065	0.99	1.40	
b1	.039	.053	0.99	1.35	
b2	.065	.094	1.65	2.39	
b3	.065	.092	1.65	2.34	
b4	.102	.135	2.59	3.43	
b5	.102	.133	2.59	3.38	
c	.015	.035	0.38	0.89	
c1	.015	.033	0.38	0.84	
D	.776	.815	19.71	20.70	4
D1	.515	-	13.08	-	5
D2	.020	.053	0.51	1.35	
E	.602	.625	15.29	15.87	4
E1	.530	-	13.46	-	
E2	.178	.216	4.52	5.49	
e	.215 BSC		5.46 BSC		
Øk	.010		0.25		
L	.780	.827	19.57	21.00	
L1	.146	.169	3.71	4.29	
ØP	.140	.144	3.56	3.66	
ØP1	-	.291	-	7.39	
Q	.209	.224	5.31	5.69	
S	.217 BSC		5.51 BSC		

**LEAD ASSIGNMENTS**

**HEXFET**

- 1.- GATE
- 2.- DRAIN
- 3.- SOURCE
- 4.- DRAIN

**IGBTs, CoPACK**

- 1.- GATE
- 2.- COLLECTOR
- 3.- EMITTER
- 4.- COLLECTOR

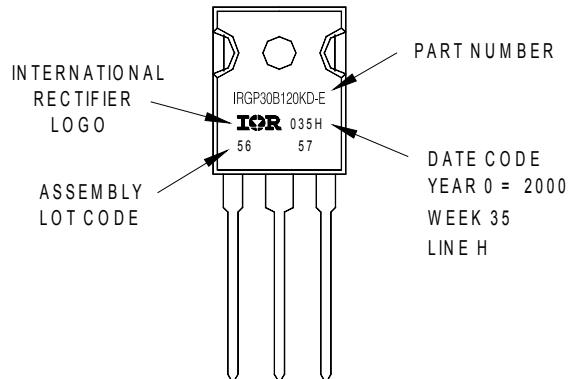
**DIODES**

- 1.- ANODE/OPEN
- 2.- CATHODE
- 3.- ANODE

## TO-247AD Part Marking Information

EXAMPLE: THIS IS AN IRGP30B120KD-E  
WITH ASSEMBLY  
LOT CODE 5657  
ASSEMBLED ON WW 35, 2000  
IN THE ASSEMBLY LINE "H"

Note: "P" in assembly line position  
indicates "Lead-Free"



TO-247AD package is not recommended for Surface Mount Application.

Note: For the most current drawing please refer to IR website at <http://www.irf.com/package/>

**Qualification Information<sup>†</sup>**

<b>Qualification Level</b>	Industrial <sup>†</sup> (per JEDEC JESD47F) <sup>††</sup>	
<b>Moisture Sensitivity Level</b>	TO-220	N/A
	TO-247AC	
	TO-247AD	
<b>RoHS Compliant</b>	Yes	

† Qualification standards can be found at International Rectifier’s web site: <http://www.irf.com/product-info/reliability/>

†† Applicable version of JEDEC standard at the time of product release.

**Revision History**

<b>Date</b>	<b>Comments</b>
12/12/2014	<ul style="list-style-type: none"> <li>Added TO-220 package in the datasheet.</li> </ul>