

# OPTIREG™ Linear TLT807B0EPV

## Low dropout adjustable standby voltage regulator for truck applications



### Features

- Adjustable output voltage at  $\pm 2\%$  accuracy for output current up to 70 mA
- Very low current consumption: typically 36  $\mu\text{A}$
- Very low dropout voltage
- Input voltage up to 42 V
- Overvoltage protection up to 58 V ( $< 400$  ms)
- Enable input, active high
- Protection functions:
  - Output current limitation for overload and short circuit conditions
  - Reverse polarity protection
  - Overtemperature shutdown
- Wide temperature range  $-40^{\circ}\text{C}$  to  $150^{\circ}\text{C}$
- Infineon automotive quality
- Grade 1 for extended mission profiles
- Green Product (RoHS compliant)

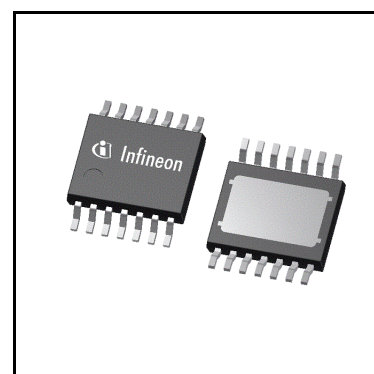

### Potential applications

- 24 V applications, such as:
  - Truck applications
  - Commercial Agricultural Vehicle (CAV) applications
  - Construction vehicle applications
- x-EV applications
- Applications that are permanently connected to the battery

### Product validation

Qualified for automotive applications with extended lifetime requirements. Product validation according to AEC-Q100.

### Description

The TLT807B0EPV is a monolithic integrated low dropout adjustable voltage regulator in a small surface mounted package for the harsh environment of automotive applications.

# OPTIREG™ Linear TLT807B0EPV

Low dropout adjustable standby voltage regulator for truck applications

---



Type	Package	Marking
TLT807B0EPV	PG-TSDSO-14	T807B0

## Table of contents

	<b>Features</b> .....	<b>1</b>
	<b>Potential applications</b> .....	<b>1</b>
	<b>Product validation</b> .....	<b>1</b>
	<b>Description</b> .....	<b>1</b>
	<b>Table of contents</b> .....	<b>3</b>
<b>1</b>	<b>Block diagram</b> .....	<b>4</b>
<b>2</b>	<b>Pin configuration</b> .....	<b>5</b>
2.1	Pin assignment PG-TSDSO-14 .....	5
2.2	Pin definitions and functions PG-TSDSO-14 .....	5
<b>3</b>	<b>General product characteristics</b> .....	<b>6</b>
3.1	Absolute maximum ratings .....	6
3.2	Functional range .....	7
3.3	Thermal resistance .....	7
<b>4</b>	<b>Block description and electrical characteristics</b> .....	<b>8</b>
4.1	Voltage regulation .....	8
4.2	Typical performance characteristics voltage regulation .....	10
4.3	Current consumption .....	12
4.4	Typical performance characteristics current consumption .....	13
4.5	Enable .....	14
4.6	Typical performance characteristics enable .....	15
<b>5</b>	<b>Application information</b> .....	<b>16</b>
<b>6</b>	<b>Package information</b> .....	<b>17</b>
<b>7</b>	<b>Revision history</b> .....	<b>18</b>

Block diagram

1 Block diagram

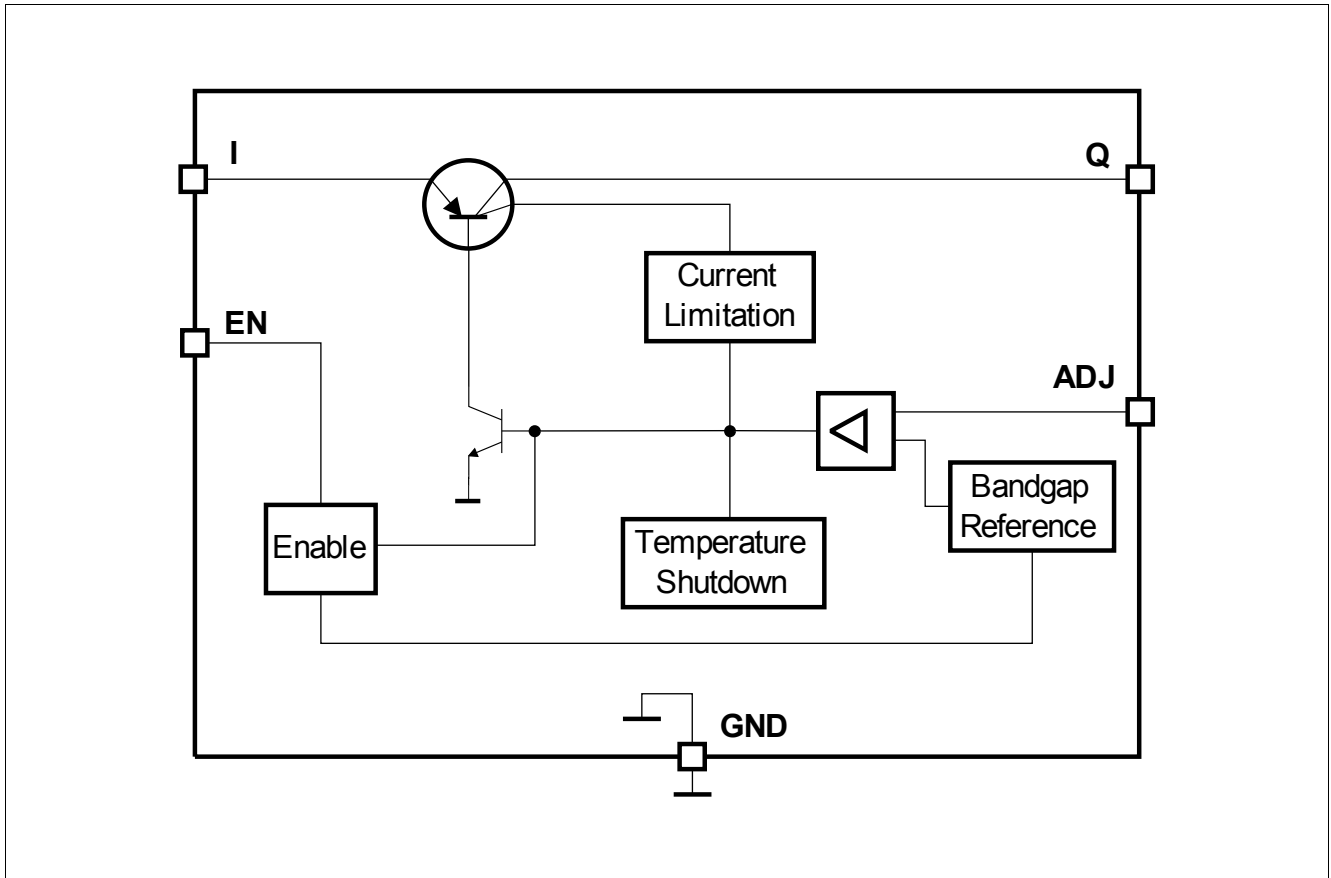

Figure 1 Block diagram

## Pin configuration

## 2 Pin configuration

### 2.1 Pin assignment PG-TSDSO-14

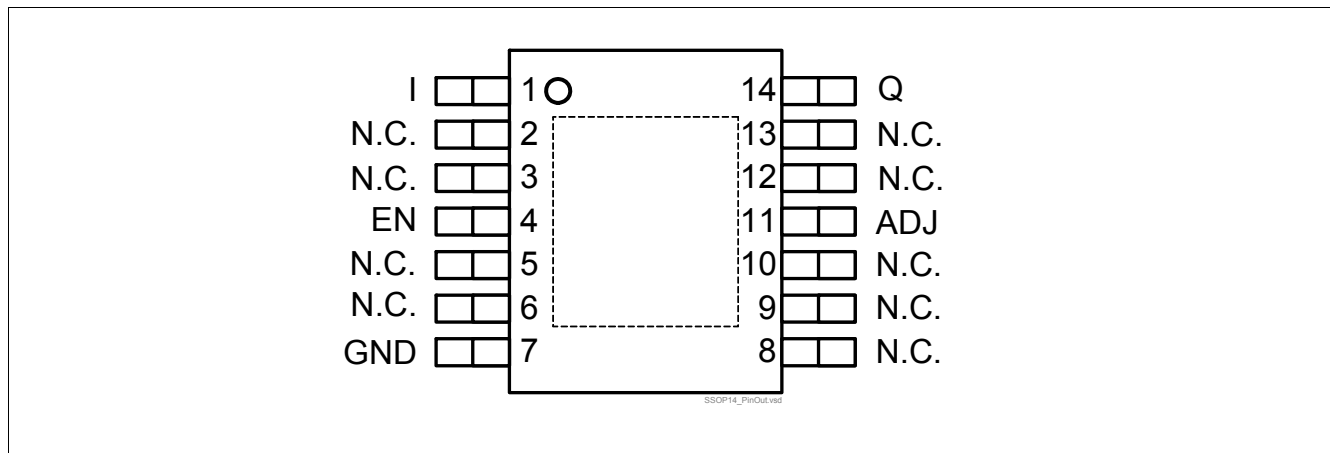

Figure 2 Pin assignment

### 2.2 Pin definitions and functions PG-TSDSO-14

Pin No.	Symbol	Function
1	I	<b>Input</b> In order to compensate line influence, it is recommended to connect a small ceramic capacitor (for example 100 nF) to GND, close to the pins.
4	EN	<b>Enable input</b> with integrated pull-down resistor. <ul style="list-style-type: none"> <li>“high” signal enables the TLT807B0EPV</li> <li>“low” signal disables the TLT807B0EPV</li> </ul>
7	GND	<b>Ground</b>
11	ADJ	<b>Voltage adjustment</b> Connect a resistive divider to determine the output voltage.
14	Q	<b>Output</b> Connect an output capacitor $C_Q$ to GND close to the pins. $C_Q$ must maintain the capacitance and ESR values specified in <b>“Functional range” on Page 7</b>
2, 3, 5, 6, 8, 9, 10, 12, 13	N.C.	<b>Not connected</b>
Exposed Pad	EP	<b>Exposed pad</b> Connect to GND and heatsink area

## General product characteristics

### 3 General product characteristics

#### 3.1 Absolute maximum ratings

**Table 1 Absolute maximum ratings<sup>1)</sup>**
 $T_j = -40^\circ\text{C}$  to  $150^\circ\text{C}$ ; all voltages with respect to ground (unless otherwise specified)

Parameter	Symbol	Values			Unit	Note or Test Condition	Number
		Min.	Typ.	Max.			
<b>Input I, Enable EN</b>							
Voltage	$V_I, V_{EN}$	-42	-	45	V	-	P_4.1.1
Voltage	$V_I, V_{EN}$	-42	-	58	V	t < 400 ms	P_4.1.2
<b>Output Q</b>							
Voltage	$V_Q$	-0.3	-	36	V	-	P_4.1.3
<b>Adjust ADJ</b>							
Voltage	$V_{ADJ}$	-0.3	-	16	V	-	P_4.1.4
<b>Temperature</b>							
Junction temperature	$T_j$	-40	-	150	°C	-	P_4.1.5
Storage temperature	$T_{stg}$	-55	-	150	°C	-	P_4.1.6
<b>ESD susceptibility</b>							
ESD susceptibility to GND	$V_{ESD,HBM}$	-2	-	2	kV	Human Body Model (HBM) <sup>2)</sup>	P_4.1.7
ESD susceptibility to GND	$V_{ESD,CDM}$	-750	-	750	V	Charged Device Model (CDM) <sup>3)</sup> at all pins	P_4.1.8

1) Not subject to production test, specified by design

2) ESD susceptibility Human Body Model "HBM" according to AEC-Q100-002 - JESD22-A114

3) ESD susceptibility Charged Device Model "CDM" according to ESDA STM5.3.1

*Note:*

1. Stresses above the ones listed here may cause permanent damage to the device. Exposure to absolute maximum rating conditions for extended periods may affect device reliability.
2. Integrated protection functions are designed to prevent IC destruction under fault conditions described in the data sheet. Fault conditions are considered as "outside" normal operating range. Protection functions are not designed for continuous repetitive operation.

## General product characteristics

## 3.2 Functional range

Table 2 Functional range

Parameter	Symbol	Values			Unit	Note or Test Condition	Number
		Min.	Typ.	Max.			
Input voltage range	$V_I$	4.7 or $V_{Q,nom} + V_{dr}$	–	42	V	– <sup>1)</sup>	P_4.2.1
Output capacitor's requirements for stability <sup>2)</sup>	$C_Q$	1	–	–	μF	– <sup>3)</sup>	P_4.2.2
Output capacitor's ESR requirements for stability	$ESR(C_Q)$	–	–	4	Ω	–	P_4.2.3
Junction temperature	$T_j$	-40	–	150	°C	–	P_4.2.4

1) The minimum input voltage is the higher one of the following values: 4.7 V and  $V_{Q,nom} + V_{dr}$ .

2) Not subject to production test, specified by design.

3) The minimum output capacitance requirement is applicable for a worst case capacitance tolerance of 30%.

*Note:* Within the functional or operating range, the IC operates as described in the circuit description. The electrical characteristics are specified within the conditions given in the Electrical Characteristics table.

## 3.3 Thermal resistance

*Note:* This thermal data was generated in accordance with JEDEC JESD51 standards. For more information, go to [www.jedec.org](http://www.jedec.org).

Table 3 Thermal Resistance

Parameter	Symbol	Values			Unit	Note or Test Condition	Number
		Min.	Typ.	Max.			
<b>TLT807B0EPV (PG-TSDSO-14)</b>							
Junction to case <sup>1)</sup>	$R_{thJC}$	–	14	–	K/W	Measured to heat slug	P_4.3.1
Junction to ambient	$R_{thJA}$	–	47	–	K/W	FR4 2s2p board <sup>2)</sup>	P_4.3.2
Junction to ambient	$R_{thJA}$	–	143	–	K/W	FR4 1s0p board, footprint only <sup>3)</sup>	P_4.3.3
Junction to ambient	$R_{thJA}$	–	66	–	K/W	FR4 1s0p board, 300 mm <sup>2</sup> heatsink area <sup>3)</sup>	P_4.3.4
Junction to ambient	$R_{thJA}$	–	56	–	K/W	FR4 1s0p board, 600 mm <sup>2</sup> heatsink area <sup>3)</sup>	P_4.3.5

1) Not subject to production test, specified by design.

2) Specified  $R_{thJA}$  value is according to Jedec JESD51-2,-5,-7 at natural convection on FR4 2s2p board; The Product (Chip and package) was simulated on a 76.2 x 114.3 x 1.5 mm<sup>3</sup> board with 2 inner copper layers (2 x 70 μm Cu, 2 x 35 μm Cu). Where applicable a thermal via array under the exposed pad contacted the first inner copper layer.

3) Specified  $R_{thJA}$  value is according to Jedec JESD 51-3 at natural convection on FR4 1s0p board; The Product (Chip and package) was simulated on a 76.2 x 114.3 x 1.5 mm<sup>3</sup> board with 1 copper layer (1 x 70 μm Cu).

## 4 Block description and electrical characteristics

### 4.1 Voltage regulation

The output voltage  $V_Q$  feeds a resistive divider. The fraction voltage from the output of the resistive divider feeds the ADJ pin. The TLT807B0EPV compares the voltage at the ADJ pin to an internal voltage reference, and drives the pass transistor accordingly.

#### Stability

The control loop stability of the TLT807B0EPV depends on:

- output capacitor  $C_Q$
- load current
- chip temperature

To ensure stable operation, the output capacitor  $C_Q$  must maintain the capacitance and ESR values specified in **“Functional range” on Page 7**. For details see the typical performance graph **Output capacitor series resistor ESR(CQ) versus Output current IQ**. Size the output capacitor according to the application’s needs, so that it can buffer load steps.

#### Compensation for line influence

An input capacitor  $C_I$  is recommended to compensate line influence. An additional reverse polarity protection diode and a combination of several capacitors for filtering should be used. Connect the capacitors close to the pins of the TLT807B0EPV.

#### Current limit

If the output current exceeds the specified limit, for example in case of a short circuit, the TLT807B0EPV limits the output current, which leads to a decrease of the output voltage.

#### Overtemperature shutdown

In fault condition, for example due to permanent short-circuit at the output, the overtemperature shutdown circuit switches off the power stage to prevent the TLT807B0EPV from immediate destruction. After the TLT807B0EPV cools down, the regulator restarts. If the fault condition persists, oscillatory thermal behaviour occurs. As a consequence, the junction temperature exceeds the specified maximum value, which reduces the lifetime of the TLT807B0EPV significantly.



Block description and electrical characteristics

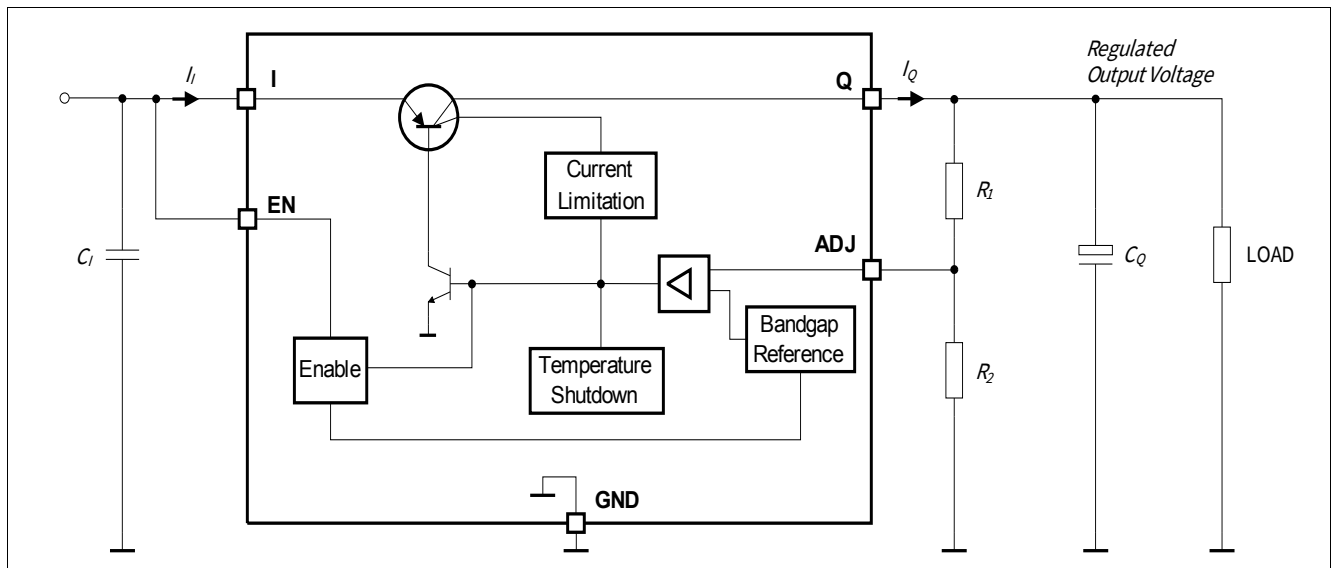

Figure 3 Block diagram voltage regulation

Table 4 Electrical characteristics voltage regulation

$V_I = 28\text{ V}$ ;  $T_j = -40^\circ\text{C}$  to  $150^\circ\text{C}$ ; all voltages with respect to ground; positive current flowing out of the pin (unless otherwise specified); typical values are given at  $T_j = 25^\circ\text{C}$

Parameter	Symbol	Values			Unit	Note or Test Condition	Number
		Min.	Typ.	Max.			
Reference voltage	$V_{Ref}$	-	1.2	-	V	-	P_5.1.1
Output voltage accuracy <sup>1)</sup>	$V_Q$	-2	-	+2	%	$100\ \mu\text{A} \leq I_Q \leq 70\ \text{mA}$ , $6\ \text{V} \leq V_I \leq 36\ \text{V}$ ,	P_5.1.2
Output voltage adjustable range	$V_Q$	1.2	-	20	V	-	P_5.1.3
Dropout voltage	$V_{dr}$	-	250	500	mV	$I_Q = 70\ \text{mA}$ , $V_Q = 5\ \text{V}$ , $V_{dr} = V_I - V_Q$ <sup>2)</sup>	P_5.1.4
Load regulation	$\Delta V_{Q, load}$	-30	-10	10	mV	$I_Q = 1\ \text{mA}$ to $70\ \text{mA}$ , $V_I = 6\ \text{V}$ , $V_Q = 5\ \text{V}$	P_5.1.5
Line regulation	$\Delta V_{Q, line}$	-20	5	20	mV	$V_I = 6\ \text{V}$ to $36\ \text{V}$ , $I_Q = 1\ \text{mA}$ , $V_Q = 5\ \text{V}$	P_5.1.6
Output current limitation	$I_{Q, max}$	71	160	280	mA	<sup>2)</sup>	P_5.1.10
Power Supply Ripple Rejection <sup>3)</sup>	$PSRR$	-	60	-	dB	$f_r = 100\ \text{Hz}$ , $V_r = 0.5\ \text{Vpp}$ , $V_Q = 5\ \text{V}$	P_5.1.11
Overtemperature shutdown threshold	$T_{j, sdt}$	151	175	200	$^\circ\text{C}$	$T_j$ increasing	P_5.1.15
Overtemperature shutdown threshold hysteresis	$T_{j, sdh}$	-	15	-	$^\circ\text{C}$	$T_j$ decreasing	P_5.1.16

1) Referring to the device tolerance only, the tolerance of the resistor divider can cause additional deviation. Parameter is tested with the ADJ pin directly connected to the output pin Q.

2) Measured when the output voltage  $V_Q$  has dropped 100 mV from the nominal value obtained at  $V_I = 28\ \text{V}$ .

3) Not subject to production test, specified by design.

### 4.2 Typical performance characteristics voltage regulation

Output voltage  $V_Q$  versus Junction temperature  $T_j$

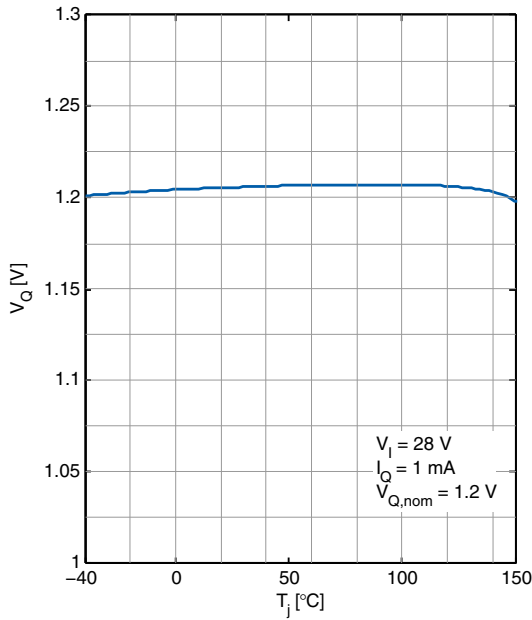

Maximum Output current  $I_{Q,max}$  versus Input voltage  $V_I$

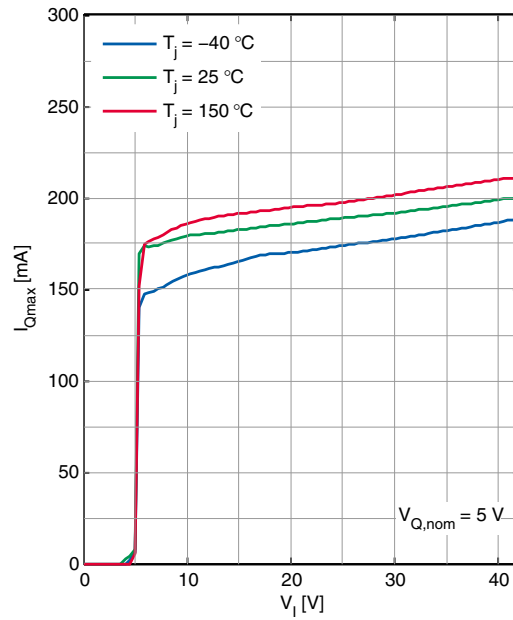

Dropout voltage  $V_{dr}$  versus Junction temperature  $T_j$

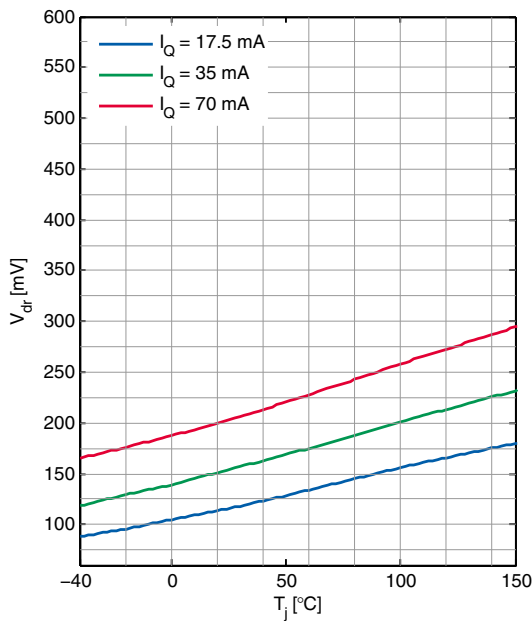

Line regulation  $\Delta V_{Q,line}$  versus Input voltage  $V_I$

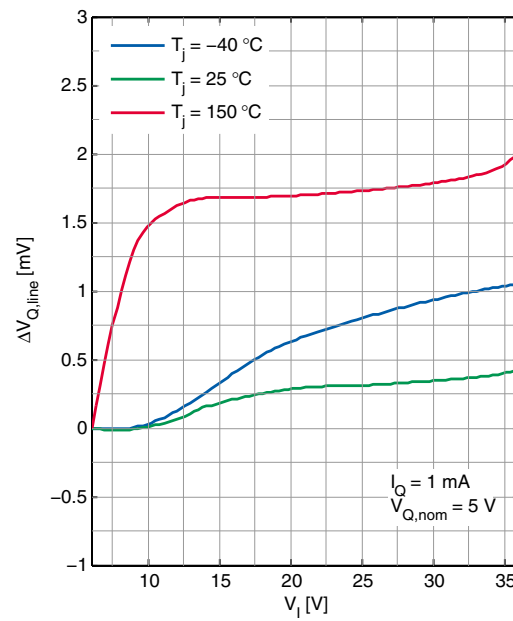

Block description and electrical characteristics

Load regulation  $\Delta V_{Q,load}$  versus Output current change  $I_Q$

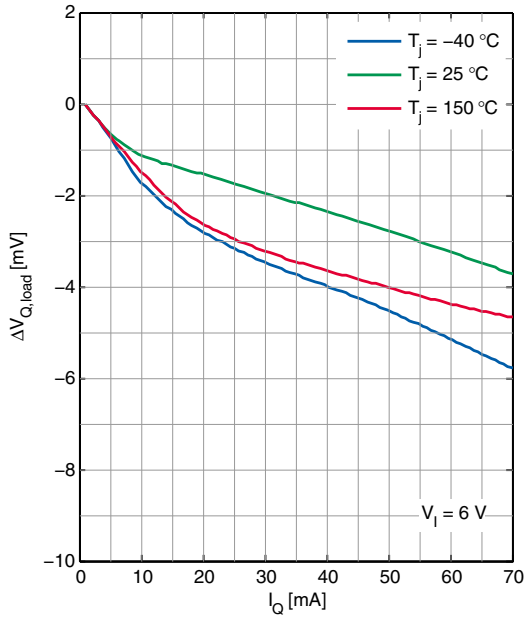

Output capacitor series resistor  $ESR(C_Q)$  versus Output current  $I_Q$

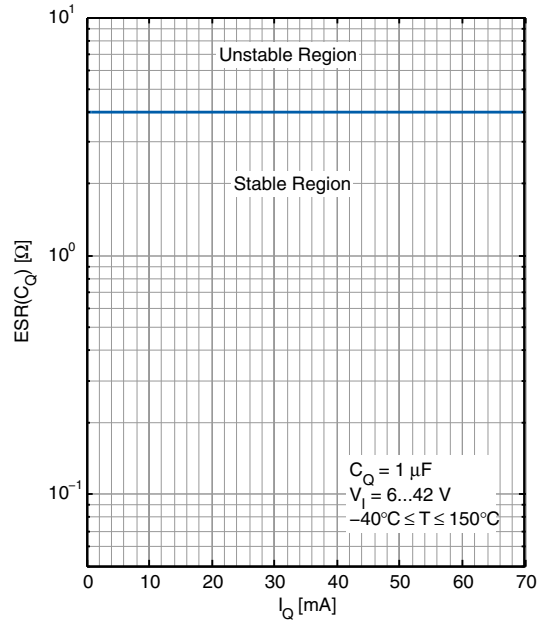

Power Supply Ripple Rejection  $PSRR$  versus ripple frequency  $f_r$

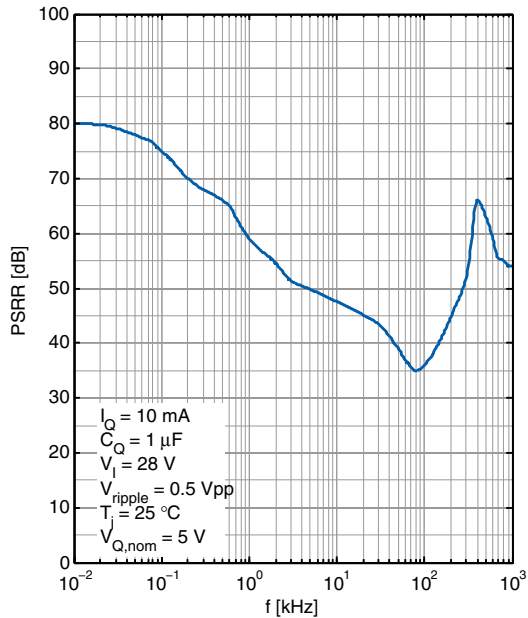

Drop voltage  $V_{dr}$  versus Output current  $I_Q$

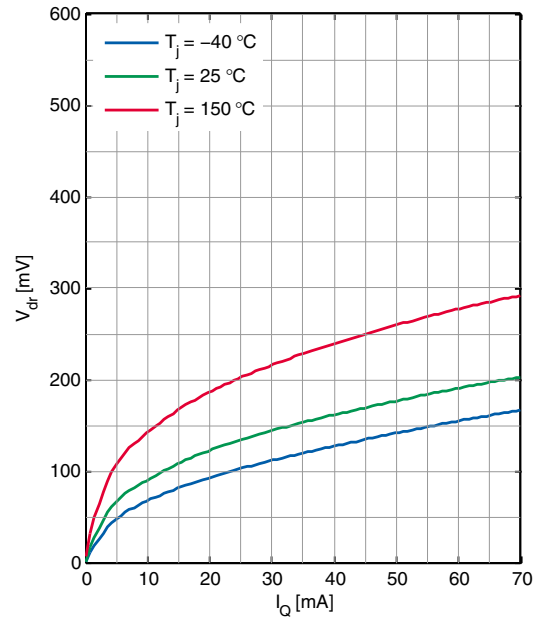

## Block description and electrical characteristics

## 4.3 Current consumption

Table 5 Electrical characteristics current consumption

$V_I = 28\text{ V}$ ;  $T_j = -40^\circ\text{C}$  to  $150^\circ\text{C}$ ; all voltages with respect to ground; positive current flowing out of the pin (unless otherwise specified); typical values are given at  $T_j = 25^\circ\text{C}$

Parameter	Symbol	Values			Unit	Note or Test Condition	Number
		Min.	Typ.	Max.			
Current consumption $I_q = I_1$	$I_{q,off}$	–	–	1.5	$\mu\text{A}$	$V_{EN} = 0\text{ V}$ , $T_j < 100^\circ\text{C}$	P_5.3.1
Current consumption $I_q = I_1 - I_Q$	$I_q$	–	36	48	$\mu\text{A}$	$I_Q = 100\ \mu\text{A}$ , $T_j < 85^\circ\text{C}$	P_5.3.2
Current consumption $I_q = I_1 - I_Q$	$I_q$	–	36	54	$\mu\text{A}$	$I_Q = 100\ \mu\text{A}$	P_5.3.3
Current consumption $I_q = I_1 - I_Q$	$I_q$	–	4	6	$\text{mA}$	$I_Q = 70\ \text{mA}$	P_5.3.4

### 4.4 Typical performance characteristics current consumption

Current consumption  $I_q$  versus Output current  $I_Q$

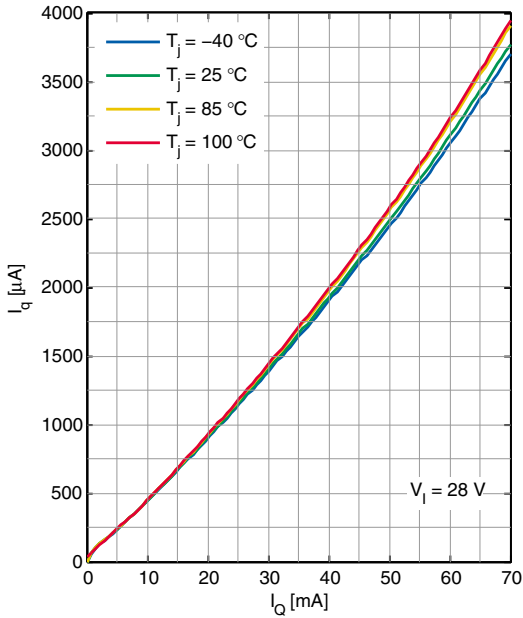

Current consumption  $I_{q,off}$  versus Junction temperature  $T_j$

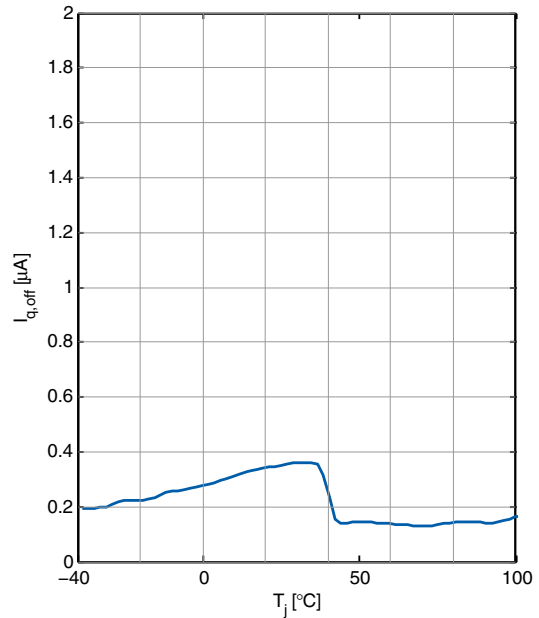

Current consumption  $I_q$  versus Input voltage  $V_I$

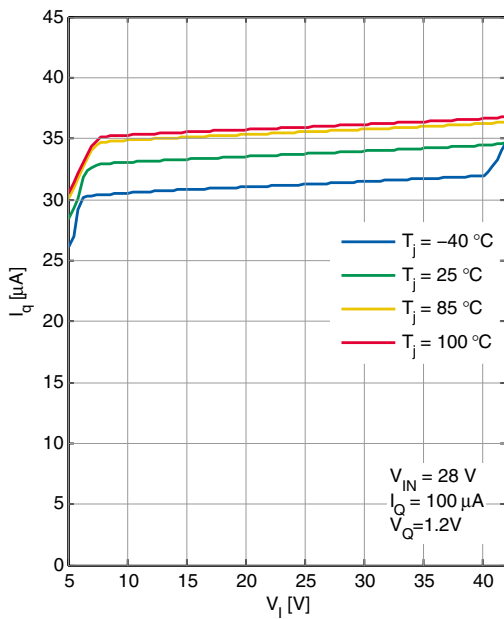

Current consumption  $I_q$  versus Junction temperature  $T_j$

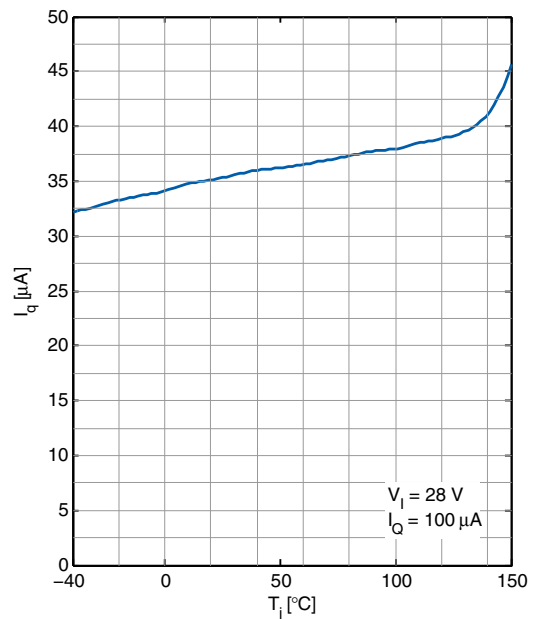

## Block description and electrical characteristics

## 4.5 Enable

The enable feature switches the TLT807B0EPV on and off via the voltage applied to the EN pin:

- connect a “high” signal (for example battery voltage) to enable the TLT807B0EPV
- connect a “low” signal (for example GND) to disable the TLT807B0EPV

The hysteresis of the enable function prevents the TLT807B0EPV from toggling between on-state and off-state due to signals with slow slopes at the EN pin.

**Table 6 Electrical characteristics enable**

$V_I = 28\text{ V}$ ;  $T_j = -40^\circ\text{C}$  to  $150^\circ\text{C}$ ; all voltages with respect to ground; positive current flowing out of the pin (unless otherwise specified); typical values are given at  $T_j = 25^\circ\text{C}$

Parameter	Symbol	Values			Unit	Note or Test Condition	Number
		Min.	Typ.	Max.			
Enable “high” level voltage	$V_{\text{EN,ON}}$	2	–	–	V	–	P_5.5.1
Enable “low” level voltage	$V_{\text{EN,OFF}}$	–	–	0.8	V	$T_j \leq 125^\circ\text{C}^{1)}$	P_5.5.2
Enable “low” level voltage	$V_{\text{EN,OFF}}$	–	–	0.4	V	–	P_5.5.3
Enable input current	$I_{\text{EN,ON}}$	–	4	8	$\mu\text{A}$	$V_{\text{EN}} = 5\text{ V}$	P_5.5.5

1) Not subject to production test, specified by design.

### 4.6 Typical performance characteristics enable

**Enable input current  $I_{EN}$  versus  
Input voltage  $V_{EN}$**

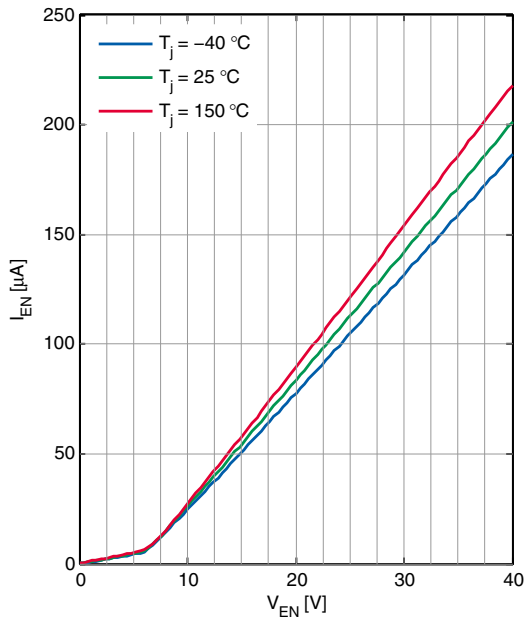

## Application information

## 5 Application information

*Note:* The following information is given as a hint for the implementation of the device only and shall not be regarded as a description or warranty of a certain functionality, condition or quality of the device.

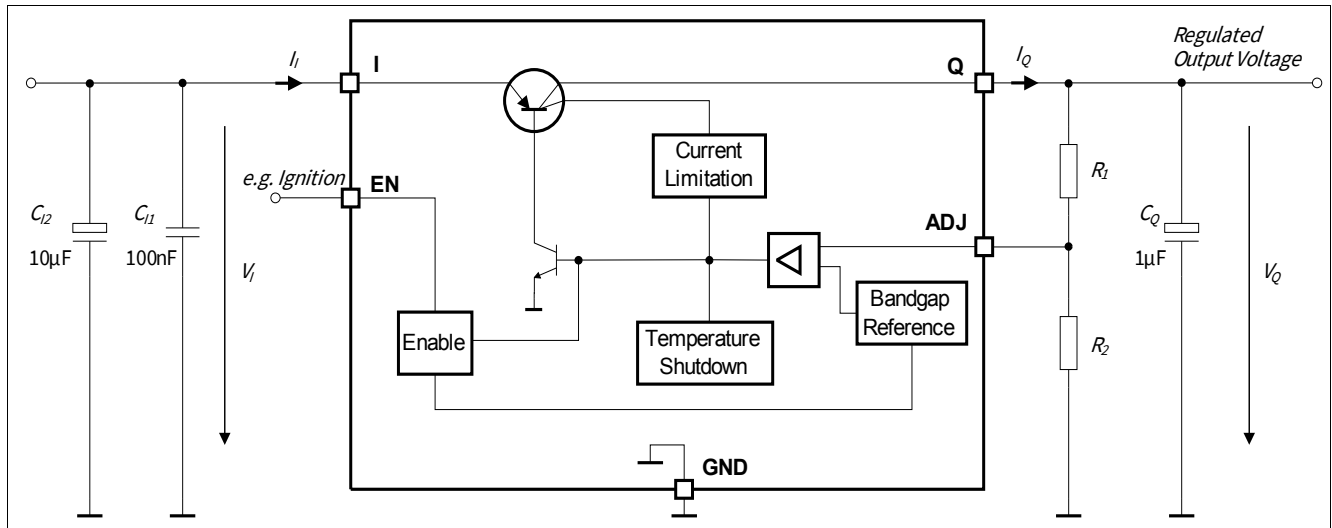

**Figure 4** Application diagram

*Note:* This is a very simplified example of an application circuit. The function must be verified in the real application.

The resistor divider for a specific output voltage can be calculated according to [Chapter 5.1](#).  $V_{ADJ}$  corresponds to  $V_{Ref}$  and is typically 1.2 V. Additionally the sum of the resistor divider should not exceed the value as stated in [Equation \(5.2\)](#).

$$\frac{R_1}{R_2} = \frac{V_Q}{V_{ADJ}} - 1 \quad (5.1)$$

$$R_1 + R_2 \leq 250 \text{ k}\Omega \quad (5.2)$$



Package information

6 Package information

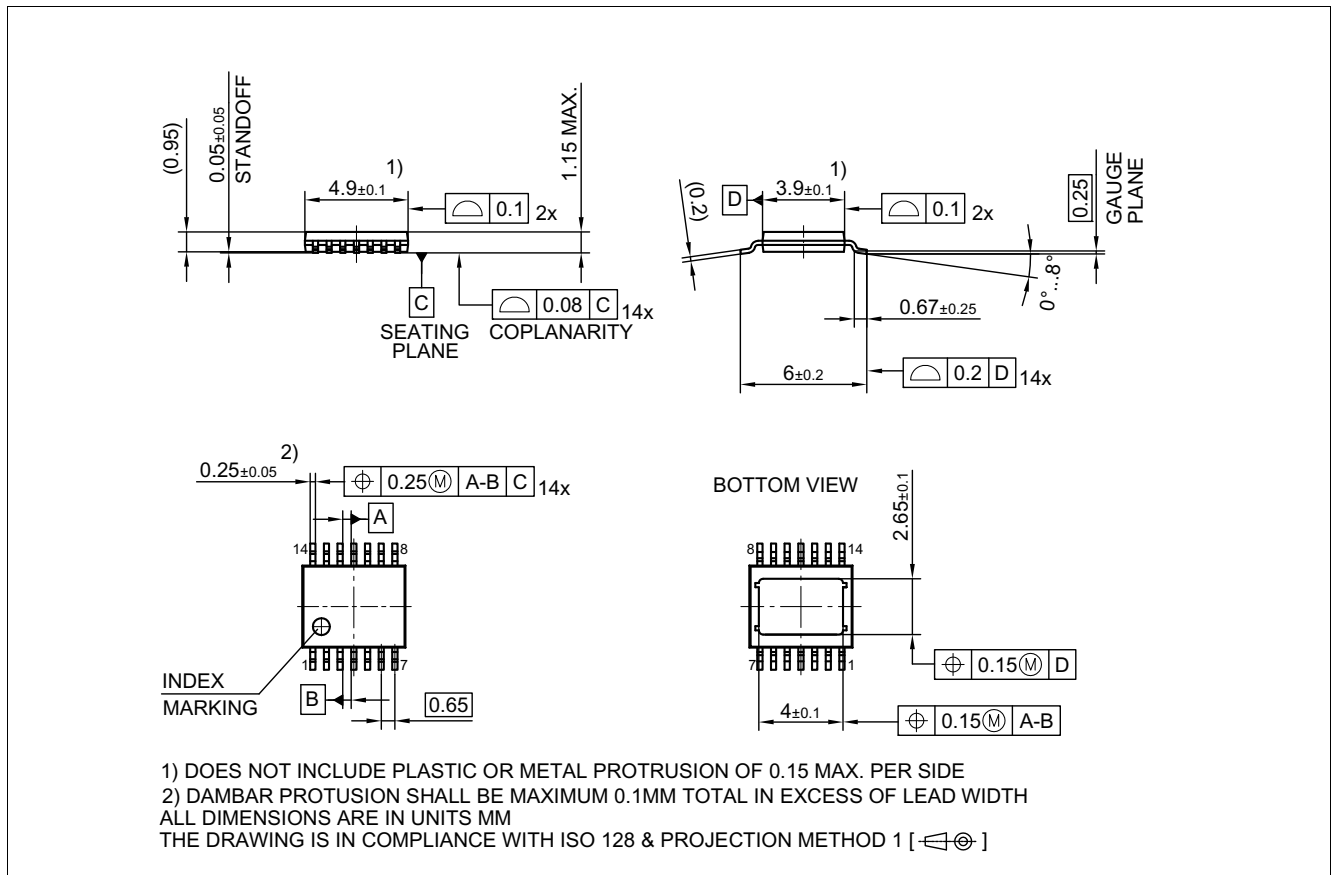

Figure 5 PG-TSDSO-14

Green Product (RoHS compliant)

To meet the world-wide customer requirements for environmentally friendly products and to be compliant with government regulations the device is available as a green product. Green products are RoHS-Compliant (i.e Pb-free finish on leads and suitable for Pb-free soldering according to IPC/JEDEC J-STD-020).

Further information on packages

<https://www.infineon.com/packages>

**Revision history****7 Revision history**

<b>Revision</b>	<b>Date</b>	<b>Changes</b>
1.01	2019-03-07	Editorial changes
1.00	2017-05-09	Data Sheet Initial version

## Trademarks

All referenced product or service names and trademarks are the property of their respective owners.

**Edition 2019-03-07**

**Published by**

**Infineon Technologies AG**

**81726 Munich, Germany**

**© 2019 Infineon Technologies AG.**

**All Rights Reserved.**

**Do you have a question about any aspect of this document?**

**Email: [erratum@infineon.com](mailto:erratum@infineon.com)**

**Document reference**

**Z8F54612515**

## IMPORTANT NOTICE

The information given in this document shall in no event be regarded as a guarantee of conditions or characteristics ("Beschaffheitsgarantie").

With respect to any examples, hints or any typical values stated herein and/or any information regarding the application of the product, Infineon Technologies hereby disclaims any and all warranties and liabilities of any kind, including without limitation warranties of non-infringement of intellectual property rights of any third party.

In addition, any information given in this document is subject to customer's compliance with its obligations stated in this document and any applicable legal requirements, norms and standards concerning customer's products and any use of the product of Infineon Technologies in customer's applications.

The data contained in this document is exclusively intended for technically trained staff. It is the responsibility of customer's technical departments to evaluate the suitability of the product for the intended application and the completeness of the product information given in this document with respect to such application.

For further information on technology, delivery terms and conditions and prices, please contact the nearest Infineon Technologies Office ([www.infineon.com](http://www.infineon.com)).

## WARNINGS

Due to technical requirements products may contain dangerous substances. For information on the types in question please contact your nearest Infineon Technologies office.

Except as otherwise explicitly approved by Infineon Technologies in a written document signed by authorized representatives of Infineon Technologies, Infineon Technologies' products may not be used in any applications where a failure of the product or any consequences of the use thereof can reasonably be expected to result in personal injury.