

## ZXLD1360EV6 EVALUATION BOARD USER GUIDE

### DESCRIPTION

The ZXLD1360EV6, Figure 1, is a double sided evaluation board for the ZXLD1360 LED driver with internal switch. The evaluation board is preset to drive a 660mA into a single LED, or an external choice of LEDs. The number of externally connected LEDs depends on the forward voltage of the LEDs connected.

The LED fitted on this evaluation board is the Lumileds™ REBEL™ led distributed by Future Lighting Solutions ([www.FutureLightingSolutions.com](http://www.FutureLightingSolutions.com))

The operating voltage is nominally 30 volts, but can be reduced to 7 volts. The 33uH inductor used in the circuit is based on this nominal supply, which should be connected across +Vin and Gnd pins. **Note: The evaluation board does not have reverse battery protection.** The nominal current for the evaluation board is set at 660mA with a 0R15 sense resistor, R1.

Alternative LEDs can be connected using the terminals marked LED A and LED K but the onboard led should be disconnected first by removing J3.

Terminal Adj provides a connection point for DC or PWM dimming and shutdown.

The evaluation board includes a thermal protection circuit to ensure the LED is not over driven under normal use. This circuit can be disabled by removing J7

Warning: At 30V nominal operation with 660mA output, the LED will be hot and very bright

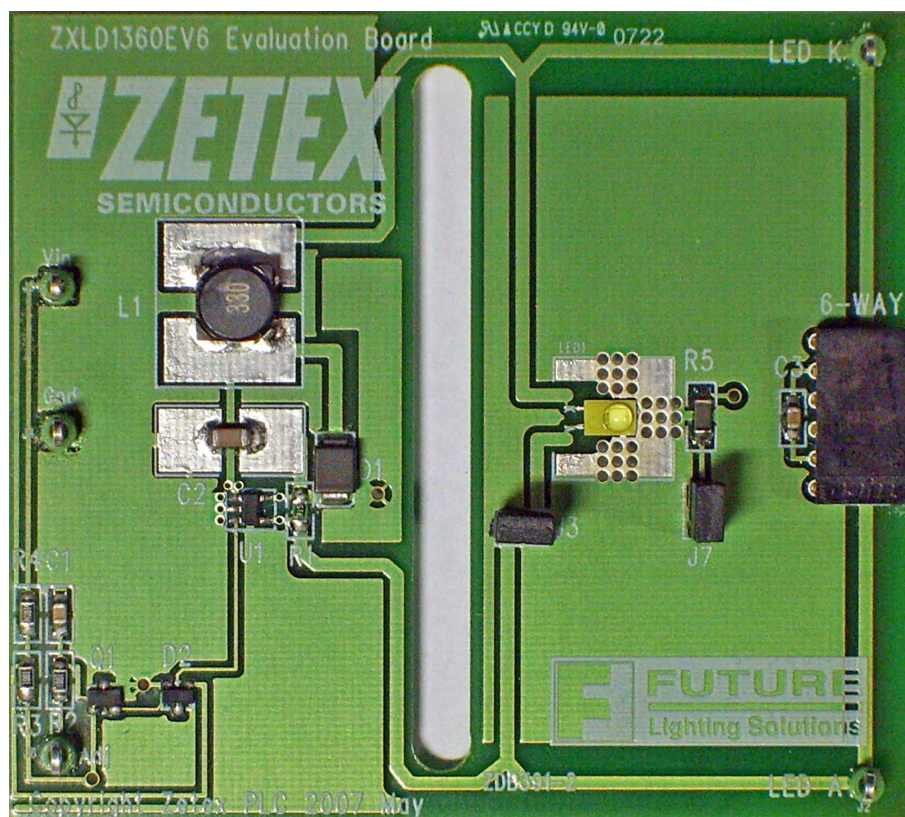

Figure 1: ZXLD1360EV6 evaluation board

**ZXLD1360 DEVICE DESCRIPTION**

The ZXLD1360 is a continuous mode inductive driver in a TSOT23-5 package, for driving one or more series-connected LEDs efficiently from a voltage source higher than the LED voltage. The device includes the output switch and a current sense circuit, which requires an external sense resistor to set the nominal current up to 1000mA.

**ZXLD1360 DEVICE FEATURES**

- Drives one or more series-connected LEDs
- LEDs up to 1000mA.
- Internal 30V switch.
- Wide input voltage: 7V to 30V.
- Inherent open circuit LED protection.
- Brightness control using DC or PWM.
- Internal PWM filter.

**DEVICE APPLICATIONS**

- LED flashlights.
- High Power LED driving.
- Low-voltage halogen replacement LEDs.
- Automotive lighting.
- Illuminated signs.

**ZXLD1360 Device Packages, Pin and Definitions**



**TSOT23-5 pack**

**ZXLD1360 Device Pin Definition**

Name	Pin No	Description
LX	1	Drain of NDMOS switch.
GND	2	Ground (0V).
ADJ	3	Internal voltage ref. pin (1.25V) : <ul style="list-style-type: none"> <li>• Leave floating for normal operation.</li> <li>• Connect to GND to turn off output current.</li> <li>• Drive with DC voltage (0.3V to 1.25V) or with PWM signal to adjust output current or....</li> <li>• Connect a capacitor from this pin to ground to set soft-start time.</li> </ul>
ISENSE	4	Connect a sense resistor, $R_s$ , from the ADJ pin to VIN to sense the nominal output current. Nominal $I_{out} = 0.1/ R1$
VIN	5	Input voltage: 7V to 30V. Decouple to ground with a 2U2F or higher ceramic capacitor.

**ORDERING INFORMATION**

<b>EVALBOARD ORDER NUMBER</b>
ZXLD1360EV6

<b>DEVICE ORDER NUMBER</b>
ZXLD1360E5TA

**Please note: Evaluation boards are subject to availability and qualified sales leads.**

### ZXLD1360EV6 EVALUATION BOARD REFERENCE DESIGN

The ZXLD1360EV6 is configured to the reference design in Figure 2. The target application is a driver for torches or other high powered LED applications.

The operating voltage is a nominal 30V. The nominal current is set at 660mA with a 0R15 sense resistor, R1 and the circuit operates in continuous mode at 300kHz approximately, with a 33uH inductor.

An accurate way of determining the current is to measure the voltage on the sense resistor. A 10K resistor and a 1uF capacitor can be used to form a low pass filter and the voltage across the capacitor represents a more stable dc reading of current. 100mV represents 1 Amp when using a 0.1Ω sense resistor.

The ADJ pin has a low pass filter within the 1360 chip to provide some decoupling and soft a start but the external capacitor C1 (100nF) is used to provide additional decoupling to reduce any high frequency noise as well as providing an extra amount of soft start.

Both DC and PWM dimming can be achieved by driving the ADJ pin. For DC dimming, the ADJ pin may be driven between 0.3V and 1.25V. Driving the ADJ pin below 0.2V will shutdown the output current. For PWM dimming, an external open-collector NPN transistor or open-drain N-channel MOSFET can be used to drive the ADJ pin. The PWM frequency can be low, around 100Hz to 1kHz, or high between 10kHz to 50kHz.

For low frequency PWM C1 should be removed on the evaluation board to give a more accurate duty cycle.

Shorting R2 will connect the test pin ADJ to device pin ADJ if needed.

The soft-start time will be nominally 0.5ms without capacitor C1. Adding C1 will increase the soft start time by approximately 0.5ms/nF

For other reference designs or further applications information, please refer to the ZXLD1360 datasheet.

### Schematic Diagram

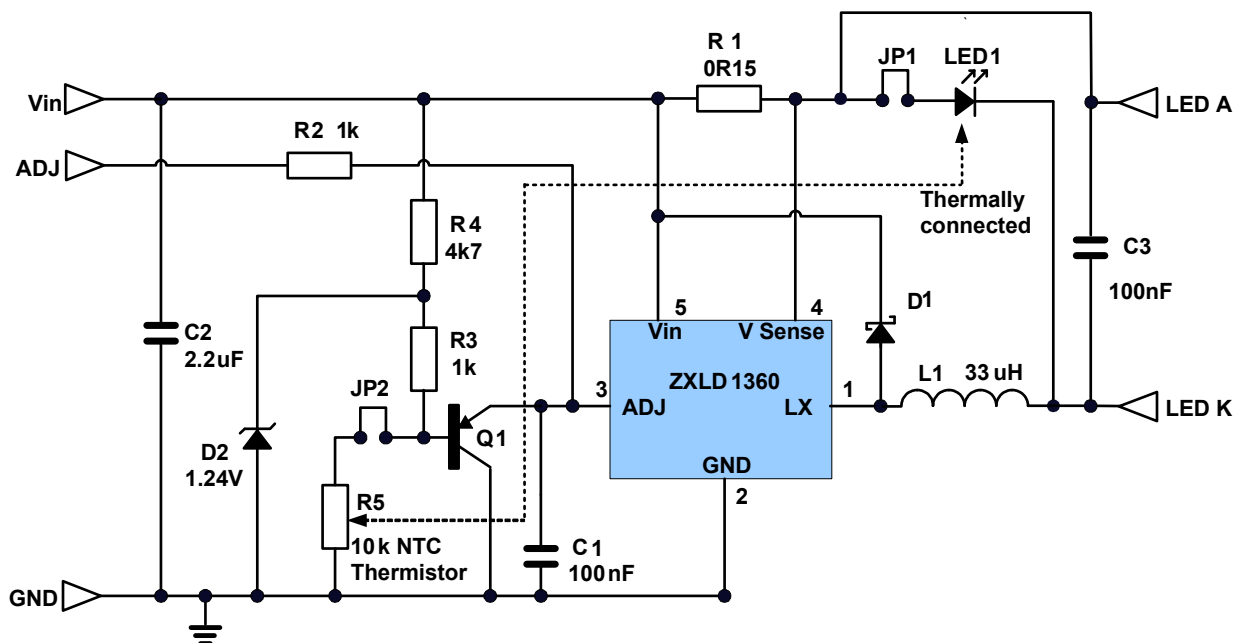

Figure 2: Schematic for the evaluation board ZXLD1360EV6

## ZXLD1360 Operation

In normal operation, when voltage is applied at +Vin, the ZXLD1360 internal NDMOS switch is turned on. Current starts to flow through sense resistor R1, inductor L1, and the LED. The current ramps up linearly, and the ramp rate is determined by the input voltage +Vin and the inductor L1. This rising current produces a voltage ramp across R1. The internal circuit of the ZXLD1360 senses the voltage across R1 and applies a proportional voltage to the input of the internal comparator. When this voltage reaches an internally set upper threshold, the NDMOS switch is turned off. The inductor current continues to flow through R1, L1, the LED and the schottky diode D1, and back to the supply rail, but it decays, with the rate of decay determined by the forward voltage drop of the LEDs and the schottky diode. This decaying current produces a falling voltage at R1, which is sensed by the ZXLD1360. A voltage proportional to the sense voltage across R1 is applied at the input of the internal comparator. When this voltage falls to the internally set lower threshold, the NDMOS switch is turned on again. This switch-on-and-off cycle continues to provide the average LED current set by the sense resistor R1. Please refer to the datasheets for the threshold limits, ZXLD1360 internal circuits, electrical characteristics and parameters.

To prevent overheating of the LED, a 10K thermistor (R5) provides feedback of the LED temperature to the base of Q1 which is held at 1.23 volts by D2 R3 and R4 at ambient 25°C. The emitter is above the ADJ voltage of the 1360 and so if full current of 1 amp is programmed by the R sense resistor the LED current reduces to around 500mA if no additional heat-sinking is provided to the eval board. The voltage on the ADJ pin is 800mV approx when the LED is hot. This function may be disabled by removing jumper link J7.

## ZXLD1360EV6 Component list

Ref	Value	Package	Part Number	Manufacturer	Notes
R1	0R15	0805		Generic	5%
R2, R3	1K	0805		Generic	1%
R4	4k7	0805		Generic	1%
R5	10K	1206	B57621C103J62	Epcos	NTC Thermistor
C1, C3	100nF, 50V	0805	NMC0805X7R104K50TRPF GRM21BR71H104KA01L	NIC Comps MURATA	X7R
C2	2u2F 50V	1206	GRM31CR71H225KA88L	MURATA	X7R
L1	33uH		NPIS64D330MTRF	NIC Comps	33uH, 1.1A rms
D1	40V, 3A		B340B		Schottky diode
D2	1.23V	SOT-23	ZRA124F01TA	Zetex	Voltage ref
U1	ZXLD1360	TSOT23-5	ZXLD1360E5TA	Zetex	DC-DC converter
LED1	LED		LXML-PWC1-0050	Lumileds	'Rebel' LED
Q1	PNP	SOT-23	BCW68H	Zetex	
6-WAY			5535676-5	TYCO	

The solder pad on the underside of the LED is connected to a heat-dissipating copper plane on the top and bottom layers which is electrically isolated from all other connections on the board.

**Warning: At 30V operation with 1000mA output, the heatsink temperature rises to 80°C from ambient after 30 minutes of operation.**

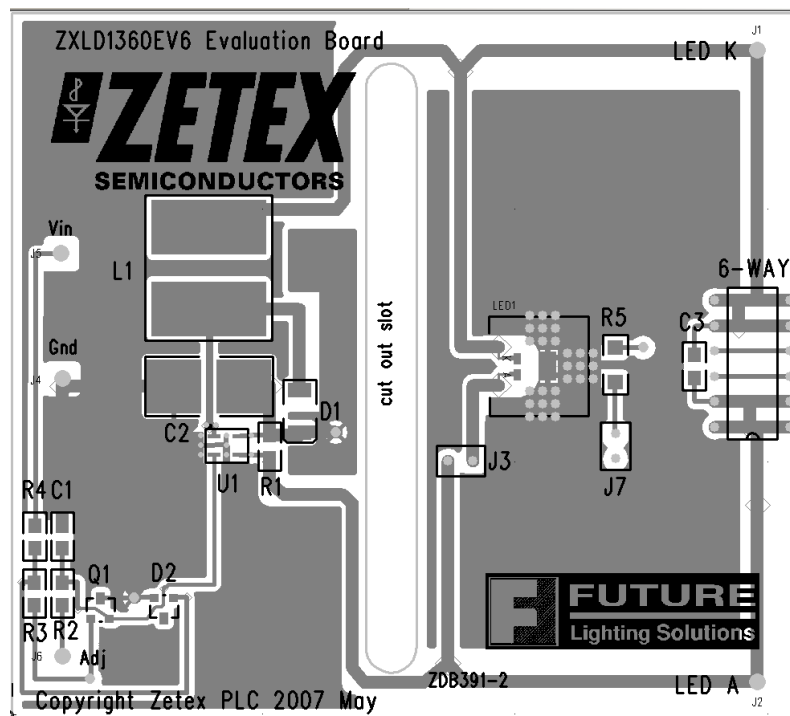

Figure 3: Component layout

ZXLD1360EV6 Connection Point Definition	
Name	Description
Vin	Positive supply voltage.
Gnd	Supply Ground (0V).
Adj	Internal voltage ref. pin (1.25). This pin can be used to achieve dimming and soft-start, and for switching the output current off. <ul style="list-style-type: none"> <li>• Leave floating for normal operation.</li> <li>• See 'Other Features' section to achieve dimming, and soft-start and for switching the output current off.</li> </ul>
LED A	LED A connects to the ANODE of LED1, and is the external LED anode connection point. Disconnect the jumper JP1 when driving an external load.
LED K	LED K connects to the CATHODE of LED1, and is the external LED cathode

**ZXLD1360EV6 Basic operation at full voltage**

1. Connect Vin and Gnd .  
Warning: The board does not feature reverse battery/supply protection.
2. Set the PSU to 30V
3. Turn on the PSU and the led will illuminate and the current should be approximately 660mA.  
Warning: Do not stare at the LED directly.

**Circuit features (Remove power whilst changing components!)****Soft-start**

1. Fit a capacitor at C1 to alter the rise-time of the adjust pin at start-up. The output impedance is 200K so  $200,000\Omega \times C1$  (farads) is the time constant to reach 66% of the maximum output current

**Switching the output current off**

1. Short the Adj pin to Gnd and the LED current will go to zero. Releasing this pin will create a soft-start power-up sequence.

**Changing the LED current**

1. Remove R1.
2. Calculate and fit a new sense resistor, R1, the value of which is based on the required LED current without dimming. R1 can be calculated using following equation :

$$R1 = 0.1V/I_{OUT} \quad \text{where } I_{OUT} = \text{the LED current.}$$

R1 = the sense resistor value in ohms.  
0.1V is the nominal sense voltage with 'Adj' open circuit or set to 1.25V.

**Using external LEDs or loads**

1. Switch off the power supply.
2. Connect external LEDs across test pins 'LED A' and 'LED K'. 'LED A' is the LEDs anode connection point and 'LED K' is the LEDs cathode connection point. The number of external LEDs that can be connected depends on their operating power and forward voltage drop. For an external load other than LEDs, the positive terminal of the load should be connected to test pin 'LED A' and the negative terminal of the load should be connected to test pin 'LED K'. The onboard led should be disconnected by removing J3.

**PERFORMANCE**

The system efficiency depends on the sense resistor, supply voltage, switching inductor and the number of LEDs

With a 30V supply the switching frequency is typically 200kHz and efficiency levels are >85% .

INTENTIONALLY BLANK

**IMPORTANT NOTICE**

DIODES INCORPORATED MAKES NO WARRANTY OF ANY KIND, EXPRESS OR IMPLIED, WITH REGARD TO THIS DOCUMENT, INCLUDING, BUT NOT LIMITED TO, THE IMPLIED WARRANTIES OF MERCHANTABILITY AND FITNESS FOR A PARTICULAR PURPOSE (AND THEIR EQUIVALENTS UNDER THE LAWS OF ANY JURISDICTION).

Diodes Incorporated and its subsidiaries reserve the right to make modifications, enhancements, improvements, corrections or other changes without further notice to this document and any product described herein. Diodes Incorporated does not assume any liability arising out of the application or use of this document or any product described herein; neither does Diodes Incorporated convey any license under its patent or trademark rights, nor the rights of others. Any Customer or user of this document or products described herein in such applications shall assume all risks of such use and will agree to hold Diodes Incorporated and all the companies whose products are represented on Diodes Incorporated website, harmless against all damages.

Diodes Incorporated does not warrant or accept any liability whatsoever in respect of any products purchased through unauthorized sales channels. Should Customers purchase or use Diodes Incorporated products for any unintended or unauthorized application, Customers shall indemnify and hold Diodes Incorporated and its representatives harmless against all claims, damages, expenses, and attorney fees arising out of, directly or indirectly, any claim of personal injury or death associated with such unintended or unauthorized application.

Products described herein may be covered by one or more United States, international or foreign patents pending. Product names and markings noted herein may also be covered by one or more United States, international or foreign trademarks.

**LIFE SUPPORT**

Diodes Incorporated products are specifically not authorized for use as critical components in life support devices or systems without the express written approval of the Chief Executive Officer of Diodes Incorporated. As used herein:

A. Life support devices or systems are devices or systems which:

1. are intended to implant into the body, or
2. support or sustain life and whose failure to perform when properly used in accordance with instructions for use provided in the labeling can be reasonably expected to result in significant injury to the user.

B. A critical component is any component in a life support device or system whose failure to perform can be reasonably be expected to cause the failure of the life support device or to affect its safety or effectiveness.

Customers represent that they have all necessary expertise in the safety and regulatory ramifications of their life support devices or systems, and acknowledge and agree that they are solely responsible for all legal, regulatory and safety-related requirements concerning their products and any use of Diodes Incorporated products in such safety-critical, life support devices or systems, notwithstanding any devices- or systems-related information or support that may be provided by Diodes Incorporated. Further, Customers must fully indemnify Diodes Incorporated and its representatives against any damages arising out of the use of Diodes Incorporated products in such safety-critical, life support devices or systems.

Copyright © 2009, Diodes Incorporated

[www.diodes.com](http://www.diodes.com)

**Sales offices****The Americas**

3050 E. Hillcrest Drive  
Westlake Village,  
CA 91362-3154  
Tel: (+1) 805 446 4800  
Fax: (+1) 805 446 4850

**Europe**

Kustermannpark  
Balanstraße 59,  
D-81541 München  
Germany  
Tel: (+49) 894 549 490  
Fax: (+49) 894 549 4949

**Taiwan**

7F, No. 50,  
Min Chuan Road  
Hsin-Tien  
Taipei, Taiwan  
Tel: (+886) 289 146 000  
Fax: (+886) 289 146 639

**Shanghai**

Rm. 606, No.1158  
Changning Road  
Shanghai, China  
Tel: (+86) 215 241 4882  
Fax (+86) 215 241 4891

**Shenzhen**

Room A1103-04,  
ANLIAN Plaza, #4018  
Jintian Road  
Futian CBD,  
Shenzhen, China  
Tel: (+86) 755 882 849 88  
Fax: (+86) 755 882 849 99

**Korea**

6 Floor, Changhwa B/D,  
1005-5 Yeongtong-dong,  
Yeongtong-gu, Suwon-si,  
Gyeonggi-do, Korea 443-813  
Tel: (+82) 312 731 884  
Fax: (+82) 312 731 885