

Product Brief

Distance2Go development kit

24 GHz sensor development kit utilizing Infineon BGT24MTR11 RF transceiver and XMC4200 32-bit ARM® Cortex®-M4 MCU series

This development kit allows the user to implement and test several sensing applications at the 24 GHz ISM band such as FMCW distance measurement, Doppler based movement detection, Doppler based direction of movement detection, and Doppler based speed measurements of targets. The kit consists of the BGT24MTR11 transceiver MMIC and a XMC4200 32-bit ARM® Cortex®-M4 for signal processing and communication via USB.

A block diagram of the demonstrator board is shown in the figure below highlighting all main board components. The board is already preprogrammed using Infineon's DAVE™ development tool. The module features a phased locked loop that is controlled with the XMC4200 to generate the FMCW ramps required for distance measurement. The MCU samples up to 2 IF channels of the transceiver chipset and communicates via USB interface to a connected PC. A provided PC application GUI (Windows XP/Vista/7/8) can be used to display and analyze acquired data in time and frequency domain. The GUI allows for the extraction of the radar time domain signals allowing for advanced debugging and algorithm development.

Applications

- › Drone soft-landing
- › Drone obstacle avoidance
- › Robotics obstacle avoidance
- › Tank level-sensing
- › Intelligent switches
- › Intelligent door opener

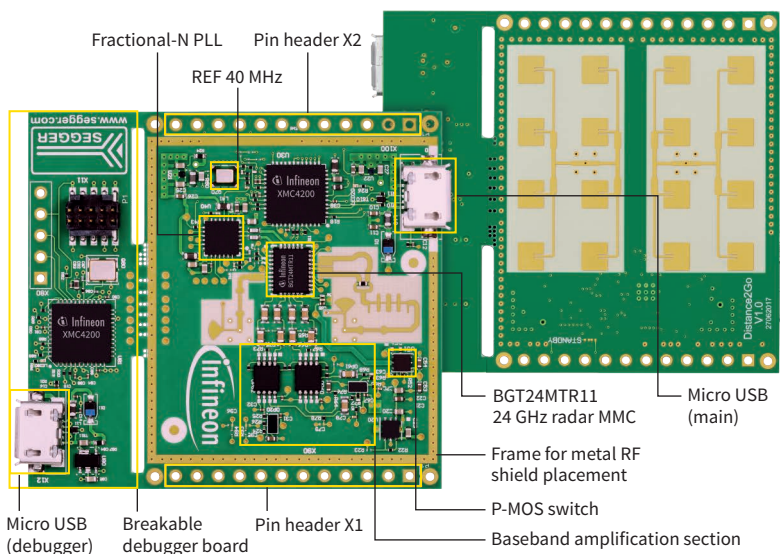

- 1) Usage of the FMCW and/or Doppler FW and SW requires agreeing to Infineon's user's agreement and licensing terms.
- 2) Maximum distance based on metal corner reflector, maximum distance up to 12 m can be achieved for human targets.

www.infineon.com/24GHz

Key features

- › Capability to detect distance of multiple targets
- › Capability to detect motion, speed and direction of movement (approaching or retreating)
- › Very small form-factor (4.5 × 3.6 cm) 24 GHz ISM band module that can be used as a development kit or mounted as a daughter board in a system
- › BGT24MTR11 – 24 GHz highly integrated RF MMIC
- › XMC4200 ARM® Cortex®-M4 – 32-bit industrial microcontroller
- › Debug over cortex 10 pin debug connector
- › Integrated multiple element patch antennas

Contents of the kit

- › 24 GHz demo board
- › User's manual
- › SW GUI to operate kit
- › FMCW FW and SW¹⁾ (also available as source code)
- › Doppler FW and SW¹⁾ (also available as source code)
- › Schematic and bill-of-materials of module

Features

- › Minimum distance: 0.5 m
- › Maximum distance: 25 m²⁾
- › Radar system field of view:
 - horizontal: 20° (simulated)
 - vertical: 42° (simulated)

Distance2Go development kit

24 GHz sensor development kit utilizing Infineon BGT24MTR11 RF transceiver and XMC4200 32-bit ARM® Cortex®-M4 MCU series

Block diagram

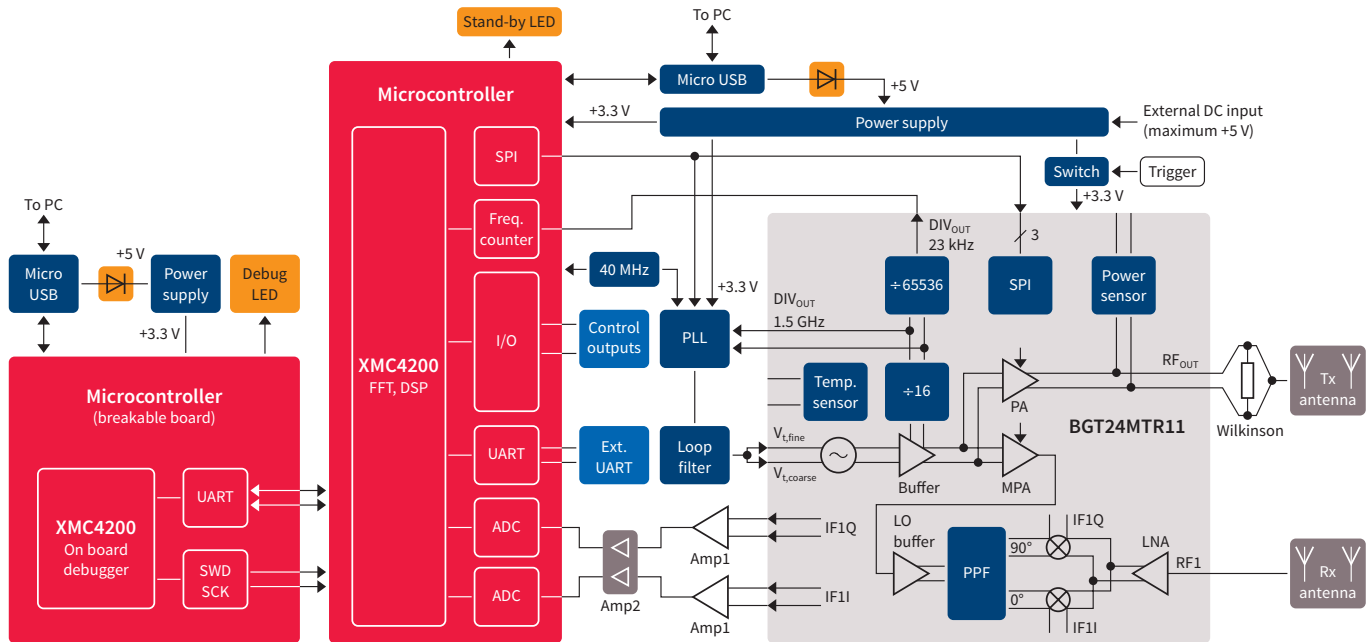

Product summary

Type	Description	Ordering code (OPN)
Distance2Go	24 GHz FMCW, Doppler demonstration board	DEMO DISTANCE2GO
BGT24MTR11	24 GHz radar chip with 1 transmitter and 1 receiver in VQFN-32-9 package	BGT24MTR11E6327XUMA1
XMC4200-Q48K256 AB	80 MHz ARM® Cortex®-M4 with high resolution PWM unit, 256 kB flash, 40 kB RAM, rich analog-mixed signal, timer/PWM and communication peripherals in VQFN-48	XMC4200Q48K256ABXUMA1
BAS3010A	Medium power AF schottky diode	BAS3010A03WE6327HTSA1
IRLTS2242	-20 V single P-channel HEXFET power MOSFET in a TSOP-6 (Micro 6) package	IRLTS2242TRPBF

Board size:

Debugger 14 mm x 45 mm
Board 36 mm x 45 mm

Published by
Infineon Technologies AG
81726 Munich, Germany

© 2017 Infineon Technologies AG.
All Rights Reserved.

Please note!

THIS DOCUMENT IS FOR INFORMATION PURPOSES ONLY AND ANY INFORMATION GIVEN HEREIN SHALL IN NO EVENT BE REGARDED AS A WARRANTY, GUARANTEE OR DESCRIPTION OF ANY FUNCTIONALITY, CONDITIONS AND/OR QUALITY OF OUR PRODUCTS OR ANY SUITABILITY FOR A PARTICULAR PURPOSE. WITH REGARD TO THE TECHNICAL SPECIFICATIONS OF OUR PRODUCTS, WE KINDLY ASK YOU TO REFER TO THE RELEVANT PRODUCT DATA SHEETS PROVIDED BY US. OUR CUSTOMERS AND THEIR TECHNICAL DEPARTMENTS ARE REQUIRED TO EVALUATE THE SUITABILITY OF OUR PRODUCTS FOR THE INTENDED APPLICATION.

WE RESERVE THE RIGHT TO CHANGE THIS DOCUMENT AND/OR THE INFORMATION GIVEN HEREIN AT ANY TIME.

Additional information

For further information on technologies, our products, the application of our products, delivery terms and conditions and/or prices, please contact your nearest Infineon Technologies office (www.infineon.com).

Warnings

Due to technical requirements, our products may contain dangerous substances. For information on the types in question, please contact your nearest Infineon Technologies office.

Except as otherwise explicitly approved by us in a written document signed by authorized representatives of Infineon Technologies, our products may not be used in any life-endangering applications, including but not limited to medical, nuclear, military, life-critical or any other applications where a failure of the product or any consequences of the use thereof can result in personal injury.

Order Number: B132-I0509-V1-7600-EU-EC-P
Date: 08 / 2017