

Product Brief

Sense2Go2 development kit

24 GHz sensor development kit utilizing Infineon XMC4200 32-bit ARM® Cortex®-M4 MCU series

This development kit allows the user to implement and test several sensing applications at the 24 GHz ISM band such as Doppler based movement detection, Doppler based direction of movement detection, Doppler based speed estimation and distance measurements of targets. The kit consists of the BGT24MTR11 transceiver MMIC and a XMC4200 32-bit ARM® Cortex®-M4 for signal processing and communication via USB.

The CPU is already preprogrammed using Infineon's DAVE™ development tool. The module also comes bundled with a stand-alone firmware for movement detection without the aid of a PC, so this platform is a good starting point for your own applications. It samples up to 2 IF channels of the transceiver chipset and communicates via USB interface to a connected PC. A provided PC application GUI (Windows XP/Vista/7/8) can be used to display and analyze acquired data in time and frequency domain.

Applications

- > Indoor/outdoor smart lighting
- > Intruder alarm
- > Motion detectors
- > Intelligent door openers

Features

- > Capability to detect motion, speed and direction of movement (approaching or retreating)
- > Very small form-factor (4 cm × 3.5 cm) 24 GHz ISM band module that can be used as a development kit size or mounted as a daughter board in a system.
- > BGT24MTR11 – 24 GHz highly integrated RF MMIC
- > XMC4200 ARM® Cortex®-M4 – 32-bit industrial microcontroller
- > Debug over cortex 10 pin debug connector
- > Low power mode
- > Integrated patch antenna

Sense2Go2 development kit – main components

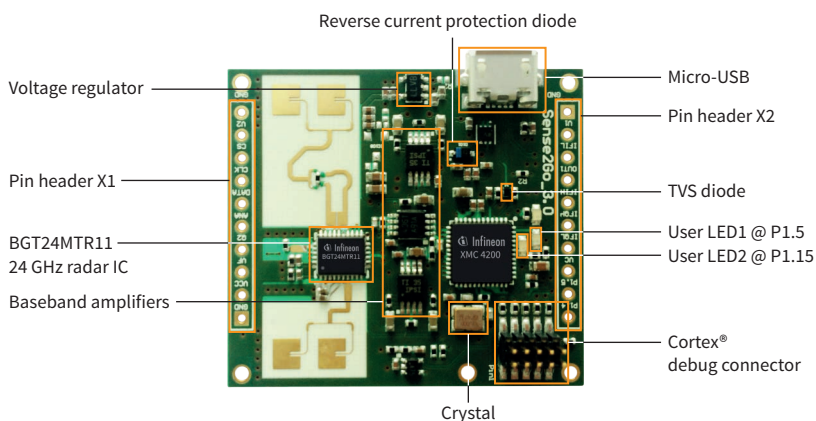

Contents of the kit includes

- > User's Manual
- > SW GUI to operate kit
- > Doppler FW and SW*
- > Schematic and Bill-of-Materials of Module
- > Micro USB-to-USB Cable (3'')

* Usage of the Doppler FW and SW requires agreeing to Infineon's user's agreement and licensing terms.

Sense2Go2 development kit

24 GHz sensor development kit utilizing Infineon XMC4200 32-bit ARM® Cortex®-M4 MCU series

Sense2Go2 block diagram

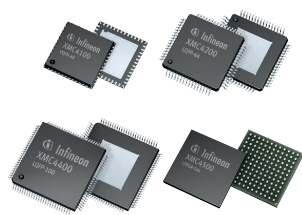
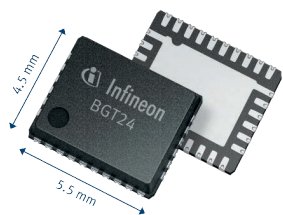
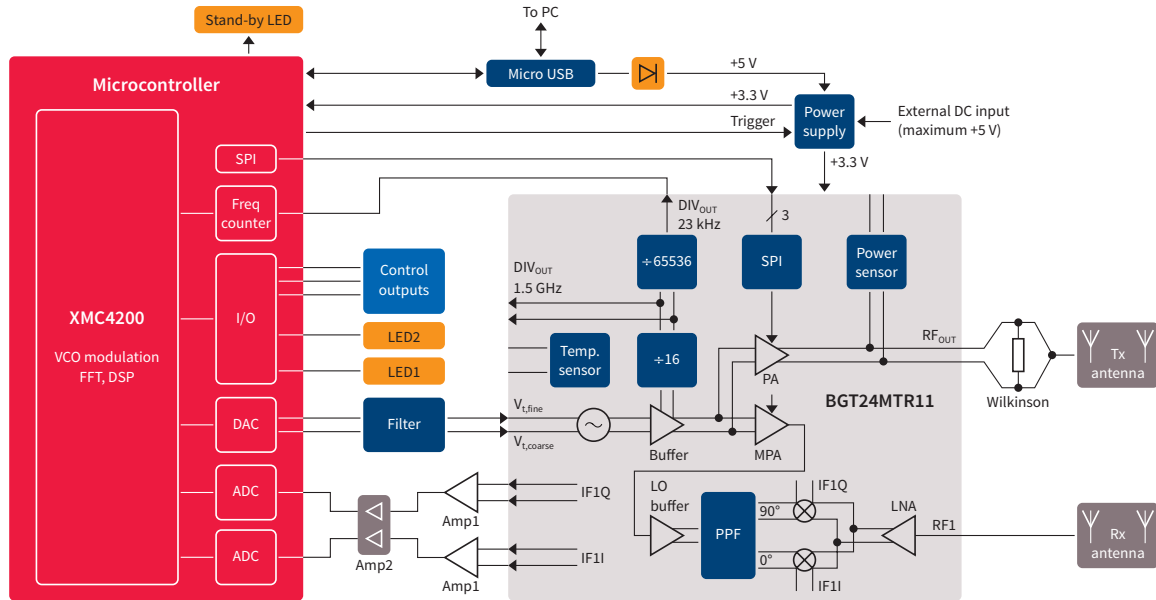

Details

- > www.infineon.com/sense2go2
- > www.infineon.com/xmc
- > www.infineon.com/dave

Product summary

Type	Description	Ordering code (OPN)
BGT24MTR11	24 GHz radar chip with 1 transmitter and 1 receiver in PG-VQFN-32-9 package	BGT24MTR11E6327XUMA1
Sense2Go2	Development kit	DEMO SENSE2GO2
XMC4200-Q48K256 AB	80 MHz ARM® Cortex®-M4 with high resolution PWM unit, 256 kB flash, 40 kB RAM, rich analog-mixed signal, timer/PWM and communication peripherals in PG-VQFN-48	XMC4200Q48K256ABXUMA1
BAS3010A-03W	Medium power schottky diode for high efficiency DC/DC conversion, fast switching, protection and clamping applications	BAS3010A03WE6327HTSA1
ESD8V0L2B-03L	Low capacitance TVS diode ESD / transient protection of high-speed data lines in a small form factor of 1.0 x 0.6 x 0.4 mm	ESD8V0L2B03LE6327XTMA1

Published by
Infineon Technologies AG
85579 Neubiberg, Germany

© 2016 Infineon Technologies AG.
All Rights Reserved.

Please note!

THIS DOCUMENT IS FOR INFORMATION PURPOSES ONLY AND ANY INFORMATION GIVEN HEREIN SHALL IN NO EVENT BE REGARDED AS A WARRANTY, GUARANTEE OR DESCRIPTION OF ANY FUNCTIONALITY, CONDITIONS AND/OR QUALITY OF OUR PRODUCTS OR ANY SUITABILITY FOR A PARTICULAR PURPOSE. WITH REGARD TO THE TECHNICAL SPECIFICATIONS OF OUR PRODUCTS, WE KINDLY ASK YOU TO REFER TO THE RELEVANT PRODUCT DATA SHEETS PROVIDED BY US. OUR CUSTOMERS AND THEIR TECHNICAL DEPARTMENTS ARE REQUIRED TO EVALUATE THE SUITABILITY OF OUR PRODUCTS FOR THE INTENDED APPLICATION.

WE RESERVE THE RIGHT TO CHANGE THIS DOCUMENT AND/OR THE INFORMATION GIVEN HEREIN AT ANY TIME.

Additional information

For further information on technologies, our products, the application of our products, delivery terms and conditions and/or prices please contact your nearest Infineon Technologies office (www.infineon.com).

Warnings

Due to technical requirements, our products may contain dangerous substances. For information on the types in question please contact your nearest Infineon Technologies office.

Except as otherwise explicitly approved by us in a written document signed by authorized representatives of Infineon Technologies, our products may not be used in any life endangering applications, including but not limited to medical, nuclear, military, life critical or any other applications where a failure of the product or any consequences of the use thereof can result in personal injury.

Order Number: B142-I0102-V4-7600-EU-EC-P
Date: 03 / 2016