

Automotive Engineering Kit (Powertrain)

Sample Kit Contents

KEMET Part Number	Series	Capacitance	Inductance	Tolerance	Size	Voltage
C0603C471K5GACAUTO	SMD Auto COG	470 pF		10%	603	50
T598D337M006ATE080	T598	330 µF		20%	7343	6.3
T495X476K035ATE300	T495	47 µF		10%	7343	35
EDH106M025S9BAA	EDH	10 µF		20%		25
EEV107M050S9MAA	EEV	100 µF		20%		50
F863BK224K310ALW0L	F863	0.22 µF		10%		310 VAC (X2)
R413N310000M1M	R41	0.1 µF		20%		1,000 VDC/300 VAC (Y2)
C4AQLBU4560A1WK	C4AQ	5.6 µF	25 nH	10%		500 VDC
C4AF9BU4150A1XK	C4AF	1.5 µF	25 nH	10%		630 VDC/310 VAC
MPLCV0654L4R7	MPLCV		4.7 µH (0.1 MHz)	20%	3126	
ESD-SR-160HL	ESD-SR-HL					
ESD-R-38SR	ESD-R-SR					
VA1210K401R014	VA	2.35 nF (1KHz)			1210	16 VDC/14 VAC
SC-02-100	SC		1000 µH			250 VAC

KEMET Part Number	Current	Temperature Range	Dielectric Type	Material Type	Effective Frequency	Quantity
C0603C471K5GACAUTO		-55/+125°C	COG			10
T598D337M006ATE080		-55/+125°C	Polymer Tantalum			10
T495X476K035ATE300		-55/+125°C	MnO2 Tantalum			2
EDH106M025S9BAA		-40/+105°C	Aluminum Electrolytic			10
EEV107M050S9MAA		-55/+105°C	Aluminum Electrolytic			6
F863BK224K310ALW0L		-40/+110°C	Metallized Polypropylene			2
R413N310000M1M		-40/+110°C	Metallized Polypropylene			4
C4AQLBU4560A1WK		-40/+105°C	Metallized Polypropylene			2
C4AF9BU4150A1XK		-55/+105°C	Metallized Polypropylene			2
MPLCV0654L4R7	10.5 A	-55/+155°C		Composite		3
ESD-SR-160HL		-40/+125°C		Ni-Zn	300 MHz	2
ESD-R-38SR		-25/+85°C			10 MHz	2
VA1210K401R014		-55/+125°C		Nickel Tin Termination		10
SC-02-100		-25/+105°C				4

COG – Millimeters (Inches)

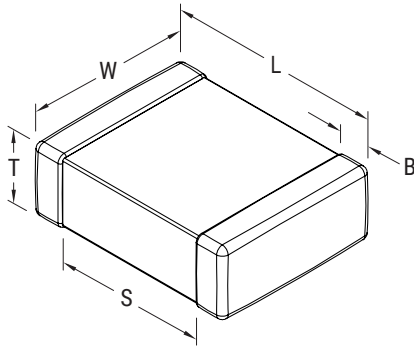

EIA Size Code	Metric Size Code	L Length	W Width	T Thickness	B Bandwidth	S Separation Minimum	Mounting Technique
0603	1608	1.60 (0.063) ±0.15 (0.006)	0.80 (0.032) ±0.15 (0.006)	See Table 2 for Thickness	0.35 (0.014) ±0.15 (0.006)	0.70 (0.028)	Solder wave or solder reflow

T598 Dimensions – Millimeters (Inches)

CATHODE (-) END VIEW

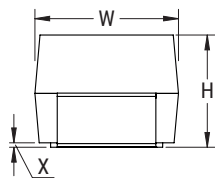

SIDE VIEW



ANODE (+) END VIEW

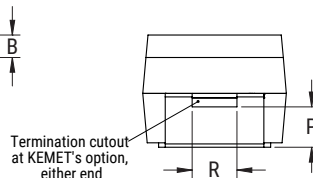

BOTTOM VIEW

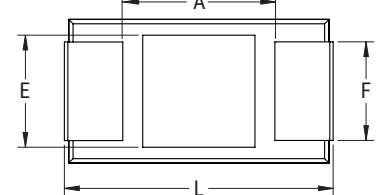

Case Size		Component											Total Weight
KEMET	EIA	L	W	H	F	S	B (Ref)	X (Ref)	P (Ref)	R (Ref)	T (Ref)	A (Min)	(mg)
D	7343-31	7.3 ±0.3 (0.287 ±0.012)	4.3 ±0.3 (0.169 ±0.012)	2.8 ±0.3 (0.110 ±0.012)	2.4 ±0.1 (0.094 ±0.004)	1.3 ±0.3 (0.051 ±0.012)	0.5 ±0.15 (0.020 ±0.006)	0.10 ±0.10 (0.004 ±0.004)	0.9 (0.035)	1.0 (0.039)	0.13 (0.005)	3.8 (0.150)	292

Notes: (Ref) – Dimensions provided for reference only.

These weights are provided as reference. If exact weights are needed, please contact your KEMET Sales Representative

T495 Dimensions – Millimeters (Inches)

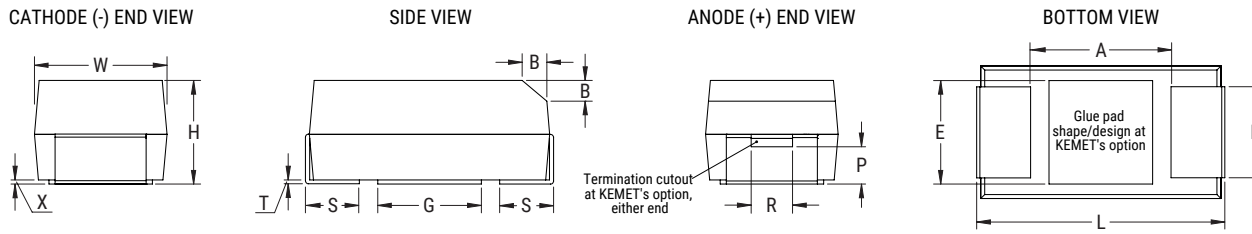

Case Size		Component													Typical Weight
KEMET	EIA	L	W	H	F ±0.1 ±(0.004)	S	B ±0.15 (Ref) ±0.006	X (Ref)	P (Ref)	R (Ref)	T (Ref)	A (Min)	G (Ref)	E (Ref)	(mg)
X	7343-43	7.3 ±0.3 (0.287 ±0.012)	4.3 ±0.3 (0.169 ±0.012)	4.0 ±0.3 (0.157 ±0.012)	2.4 (0.094)	1.3 (0.051) ±0.3 (0.012)	0.5 (0.020)	0.10 ±0.10 (0.004 ±0.004)	1.7 (0.067)	1.0 (0.039)	0.13 (0.005)	3.6 (0.142)	3.5 (0.138)	3.5 (0.138)	652.04

Notes: (Ref) – Dimensions provided for reference only. For low profile cases, no dimensions are provided for B, P, or R because these cases do not have a bevel or a notch. These weights are provided as reference. If exact weights are needed, please contact your KEMET Sales Representative

EDH and EEV Dimensions – Millimeters

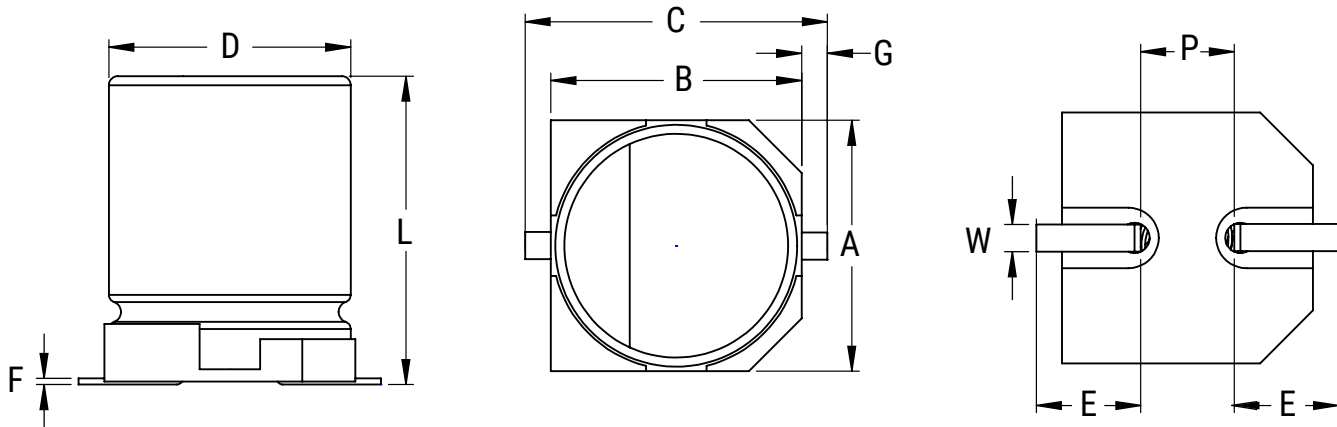

Size Code	D		L		A/B		C		E	
	Nominal	Tolerance	Nominal	Tolerance	Nominal	Tolerance	Nominal	Tolerance	Nominal	Tolerance
9B	4.0	±0.5	5.4	+0.25/-0.1	4.3	±0.2	5.5	Maximum	1.8	±0.2
9M	8	±0.5	10.2	±0.3	8.3	±0.2	10	Maximum	3.4	±0.2

Size Code	F		G		P		W	
	Nominal	Tolerance	Nominal	Tolerance	Nominal	Tolerance	Nominal	Tolerance
9B	0.3	Maximum	0.35	+0.15/-0.2	1.0	±0.2	0.65	±0.1
9M	0.3	Maximum	0.70	±0.2	3.1	±0.2	0.9	±0.2

F863 Dimensions – Millimeters

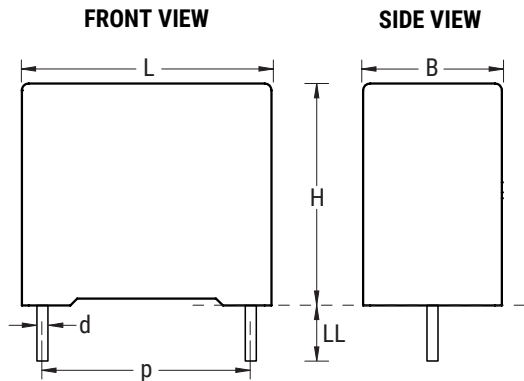

Size Code	p		B		H		L		d	
	Nominal	Tolerance	Nominal	Tolerance	Nominal	Tolerance	Nominal	Tolerance	Nominal	Tolerance
BK	15.0	±0.4	7.5	+0.2	13.5	+0.1	18.0	+0.5	0.6	±0.05

R41 Dimensions – Millimeters

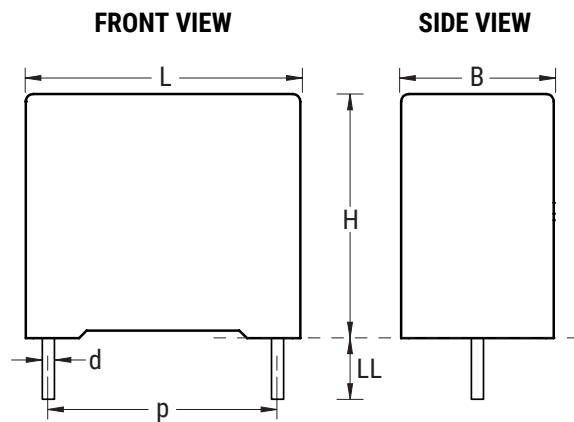

p		B		H		L		d	
Nominal	Tolerance	Nominal	Tolerance	Nominal	Tolerance	Nominal	Tolerance	Nominal	Tolerance
22.5	±0.4	6.0	+0.2	15.0	+0.1	26.5	+0.3	0.8	±0.05
22.5	±0.4	7.0	+0.2	16.0	+0.1	26.5	+0.3	0.8	±0.05
22.5	±0.4	8.5	+0.2	17.0	+0.1	26.5	+0.3	0.8	±0.05
22.5	±0.4	10.0	+0.2	18.5	+0.1	26.5	+0.3	0.8	±0.05
22.5	±0.4	13.0	+0.2	22.0	+0.1	26.5	+0.3	0.8	±0.05

C4AF and C4AQ Dimensions – Millimeters

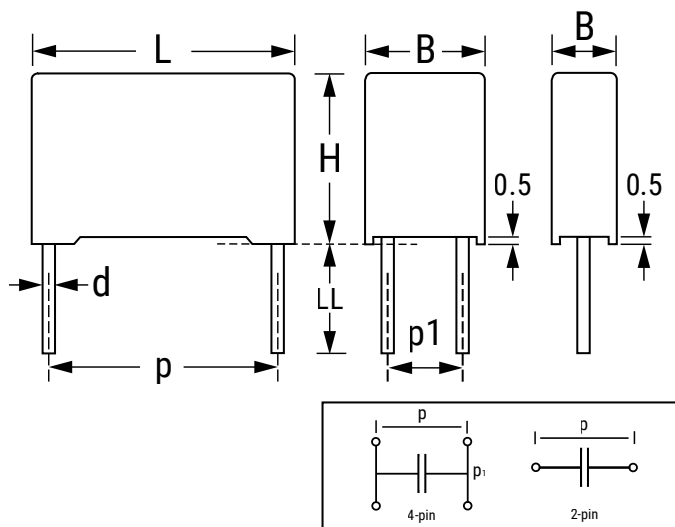

Size Code		p		p1		B		H		L		LL		d	
Digit 6	Digit 14	Nominal	Tolerance	Nominal	Tolerance	Nominal	Tolerance	Nominal	Tolerance	Nominal	Tolerance	Nominal	Tolerance	Nominal	Tolerance
B	W	27.5	±0.4	-	-	11.0	+0.3	20.0	+0.2	31.5	+0.5	6	+0/-2	0.8	±0.05
B	X	27.5	±0.4	-	-	13.0	+0.3	25.0	+0.2	31.5	+0.5	6	+0/-2	0.8	±0.05

MPLCV Dimensions – Millimeters

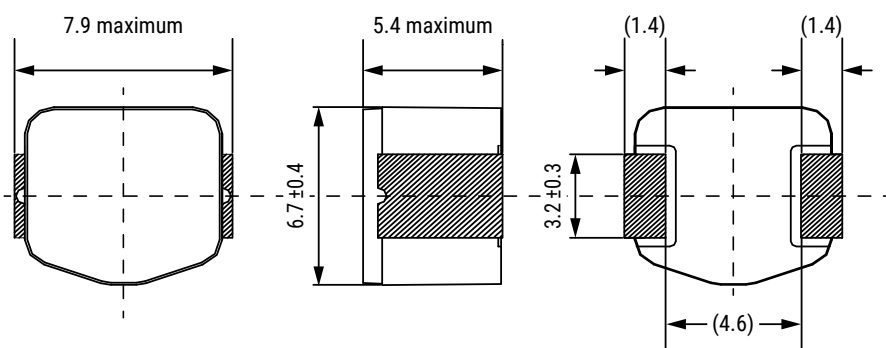

L	H	T	S
3126	7.9 Maximum	6.7 ±0.4 mm	5.4 Maximum

ESD-SR-HL Dimensions – Millimeters

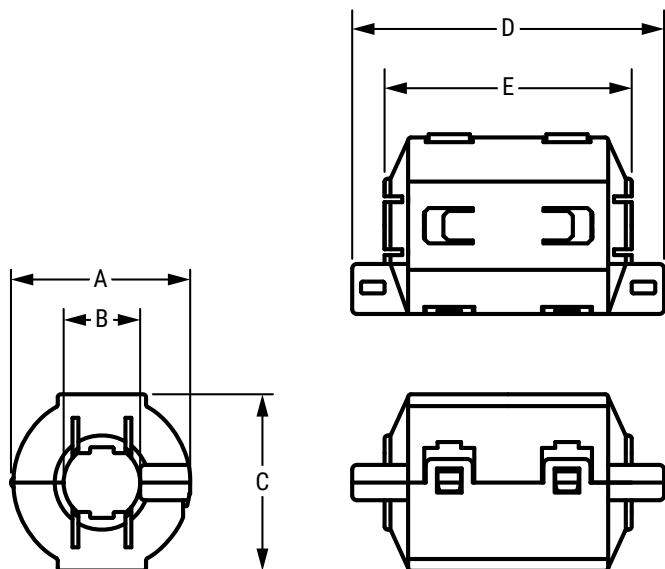

A	B	C	D	E
19.5 ±1	9 ±1	19.5 ±1	46.5 ±1	38.5 ±1

ESD-R-SR Dimensions – Millimeters

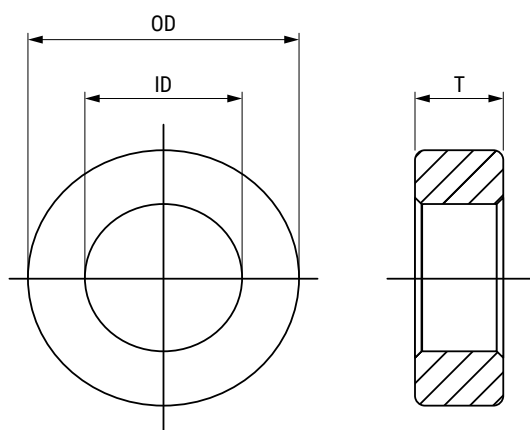

OD	ID	T
38 Maximum	19 ±0.8	12.7 ±0.5

VA Dimensions – Millimeters

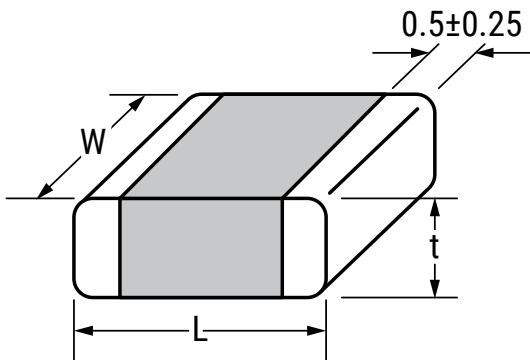

Size Code	L	W	t
1210	3.2 ± 0.30	2.50 ± 0.25	1.3 Maximum

SC Dimensions – Millimeters

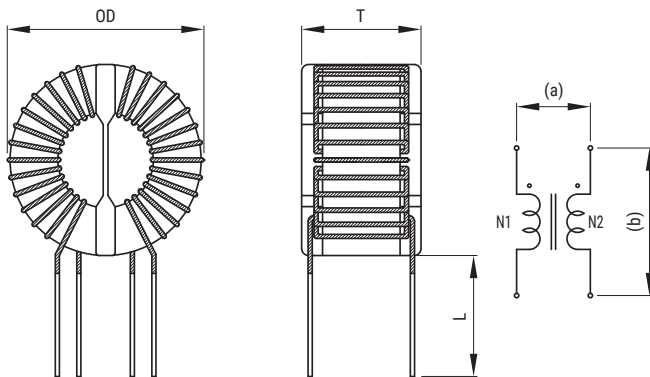

Part Name	Dimensions (mm)			Pin Pitch ¹ (Reference)	
	OD	T	L	a	b
SC-02-100	23.0 Maximum	18.5 Maximum	15.0 ± 2.0	6	17