

54F240/54F241 Buffers

54F240 Octal Inverting Buffer, 3-State
54F241 Octal Buffer, 3-State

Military Logic Products

Product Specification

DESCRIPTION

The 54F240 and 54F241 are octal buffers that are ideal for driving bus lines or buffer memory address registers. The outputs are all capable of sinking 48mA and sourcing up to 12mA, producing very good capacitive drive characteristics. The device features two output enables, (\overline{OE}), each controlling four of the 3-state outputs.

FEATURES

- 3-state buffer outputs sink 48mA and source 12mA
- Octal bus interface

ORDERING INFORMATION

DESCRIPTION	ORDER CODE
Ceramic DIP	54F240/BRA, 54F241/BRA
Ceramic Flat Pack	54F240/BSA, 54F241/BSA
Ceramic LLCC	54F240/B2A, 54F241/B2A

INPUT AND OUTPUT LOADING AND FAN-OUT TABLE

PINS	DESCRIPTION	54F(U.L.) HIGH/LOW	LOAD VALUE HIGH/LOW
$I_{aN} - I_{bN}$	Data inputs (54F240)	1.0/1.67	20 μ A/1.0mA
$I_{aN} - I_{bN}$	Data inputs (54F241)	1.0/2.67	20 μ A/1.6mA
$\overline{OE}_a, \overline{OE}_b$	Output Enable inputs (Active High)	1.0/1.67	20 μ A/1.0mA
\overline{OE}_b	3-State Output Enable input (Active Low)	1.0/1.67	20 μ A/1.0mA
$\overline{Y}_{an}, \overline{Y}_{bn}$	Data outputs (54F240)	600/80	12mA/48mA
Y_{an}, Y_{bn}	Data outputs (54F241)	600/80	12mA/48mA

NOTE: One (1.0) FAST Unit Load (U.L.) is defined as: 20 μ A in the High state and 0.6mA in the Low state.

PIN CONFIGURATION

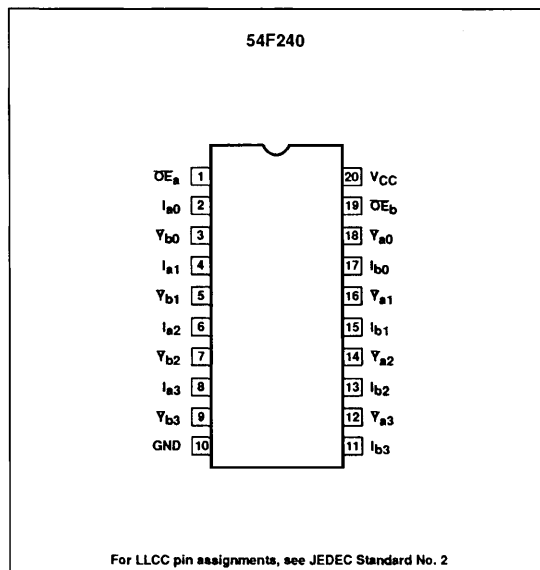

LOGIC SYMBOL

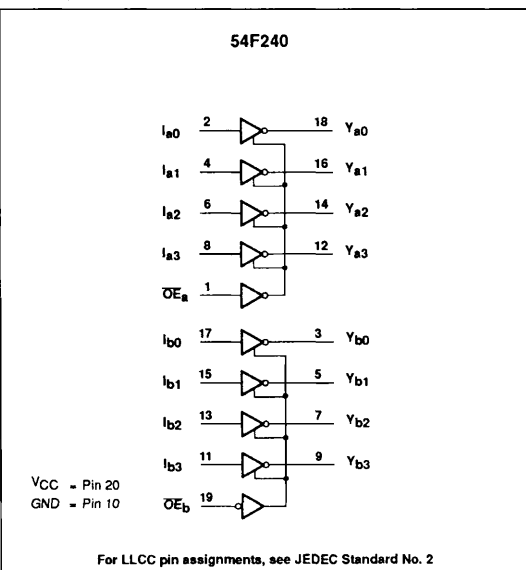

Buffers

54F240, 54F241

PIN CONFIGURATION

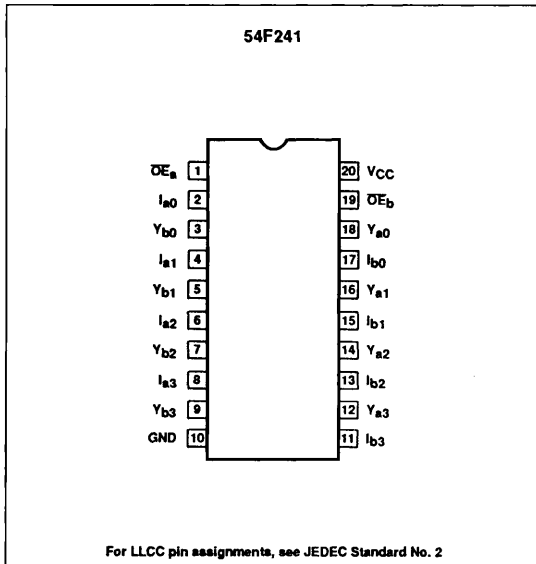

LOGIC SYMBOL

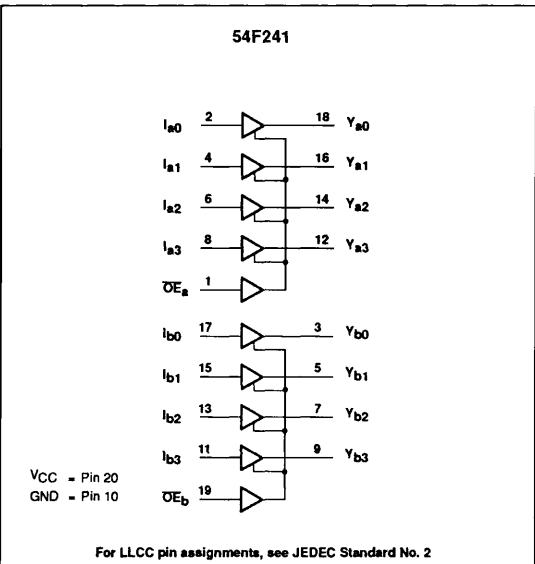

FUNCTION TABLE, 54F240

INPUTS				OUTPUTS	
OE _a	I _a	OE _b	I _b	Y _a	Y _b
L	L	L	L	H	H
L	H	L	H	L	L
H	X	H	X	Z	Z

H = High voltage level
 L = Low voltage level
 X = Don't care
 Z = High impedance "OFF" state

FUNCTION TABLE, 54F241

INPUTS				OUTPUTS	
OE _a	I _a	OE _b	I _b	Y _a	Y _b
L	L	H	L	L	L
L	H	H	H	H	H
H	X	L	X	Z	Z

H = High voltage level
 L = Low voltage level
 X = Don't care
 Z = High impedance "OFF" state

ABSOLUTE MAXIMUM RATINGS

(Operation beyond the limits set forth in this table may impair the useful life of the device. Unless otherwise noted these limits are over the operating free-air temperature range.)

SYMBOL	PARAMETER	RATING	UNIT
V _{CC}	Supply voltage range	-0.5 to +7.0	V
V _I	Input voltage range	-0.5 to +7.0	V
I _I	Input current range	-30 to +5	mA
V _O	Voltage applied to output in High output state range	-0.5 to V _{CC}	V
I _O	Current applied to output in Low output state	96	mA
T _{STG}	Storage temperature range	-65 to +150	°C

Buffers

54F240, 54F241

RECOMMENDED OPERATING CONDITIONS

SYMBOL	PARAMETER	LIMITS			UNIT
		Min	Typ	Max	
V _{CC}	Supply voltage	4.5	5.0	5.5	V
V _{IH}	High-level input voltage	2.0			V
V _{IL}	Low-level input voltage			0.8	V
I _{IK}	Input clamp current			-18	mA
I _{OH1}	High-level output current			-1	mA
I _{OH2}	High-level output current			-3	mA
I _{OH3}	High-level output current			-12	mA
I _{OL}	Low-level output current			48	mA
T _A	Operating free-air temperature range	-55		+125	°C

DC ELECTRICAL CHARACTERISTICS (Over recommended operating free-air temperature range unless otherwise noted.)

SYMBOL	PARAMETER	TEST CONDITIONS ¹	LIMITS			UNIT	
			Min	Typ ²	Max		
V _{OH}	High-level output voltage	V _{CC} = Min, I _{OH1} = -1mA	2.5			V	
		V _{IL} = Max, I _{OH2} = -3mA	2.4			V	
		V _{IH} = Min, I _{OH3} = -12mA	2.0			V	
V _{OL}	Low-level output voltage	V _{CC} = Min, V _{IL} = Max, I _{OL} = Max, V _{IH} = Min		0.35	0.50	V	
V _{IK}	Input clamp voltage	V _{CC} = Min, I _I = I _{IK}		-0.73	-1.2	V	
I _{IH2}	Input current at maximum input voltage	V _{CC} = Max, V _I = 7.0V			0.1	mA	
I _{IH1}	High-level input current	V _{CC} = Max, V _I = 2.7V		1	20	μA	
I _{IL}	Low-level input current	V _{CC} = Max, V _I = 0.5V	*F240 All inputs *F241 OE _a , OE _b		-0.6	-1.0	mA
			*F241 I _{an} , I _{bn}		-0.6	-1.6	mA
I _{OZH}	Off-state output current	V _{CC} = Max, V _{IH} = Min, V _O = 2.7V		2	50	μA	
I _{OZL}	Off-state output current	V _{CC} = Max, V _{IH} = Min, V _O = 0.5V		-2	-50	μA	
I _{OS}	Short-circuit output current ³	V _{CC} = Max, V _O = 0.0V	-100	-150	-225	mA	
I _{CC}	Supply current ⁴ (total)	V _{CC} = Max 54F240	I _{CCH}	12	29	mA	
			I _{CCL}	50	75	mA	
			I _{CCZ}	35	63	mA	
		V _{CC} = Max 54F241	I _{CCH}	40	60	mA	
			I _{CCL}	60	90	mA	
			I _{CCZ}	60	90	mA	

Buffers

54F240, 54F241

AC ELECTRICAL CHARACTERISTICS

SYMBOL	PARAMETER	TEST CONDITIONS	LIMITS					UNIT
			T _A = +25°C V _{CC} = +5.0V C _L = 50pF, R _L = 500Ω			T _A = -55°C to +125°C V _{CC} = +5.0V ± 10% C _L = 50pF, R _L = 500Ω		
			Min	Typ	Max	Min	Max	
t _{PLH} t _{PHL}	Propagation delay Data to output (54F240)	Waveform 1	3.0 2.0	4.5 3.0	6.5 4.5	3.0 1.5	9.0 5.5	ns ns
t _{PZH} t _{PZL}	Output Enable time (54F240)	Waveform 3 Waveform 4	3.0 4.5	5.0 6.5	7.5 8.5	2.0 4.0	9.5 10.5	ns ns
t _{PHZ} t _{PLZ}	Output Disable time (54F240)	Waveform 3 Waveform 4	3.0 3.0	5.5 5.0	7.0 7.0	2.5 2.5	8.0 8.5	ns ns
t _{PLH} t _{PHL}	Propagation delay Data to output (54F241)	Waveform 2	2.5 2.5	4.0 4.0	5.2 5.2	2.5 2.5	6.5 7.0	ns ns
t _{PZH} t _{PZL}	Output Enable time (54F241)	Waveform 3 Waveform 4	2.0 2.0	4.0 5.0	5.7 7.0	2.0 2.0	7.0 8.5	ns ns
t _{PHZ} t _{PLZ}	Output Disable time (54F241)	Waveform 3 Waveform 4	2.0 2.0	4.0 4.0	6.0 6.0	2.0 2.0	7.0 7.5	ns ns

NOTES:

1. For conditions shown as Min or Max, use the appropriate value specified under recommended operating conditions for the applicable type and the functional table for the applicable operating mode.
2. All typical values are at V_{CC} = 5V, T_A = 25°C.
3. Not more than one output should be shorted at a time.
4. I_{CC} is measured with outputs open.

AC WAVEFORMS

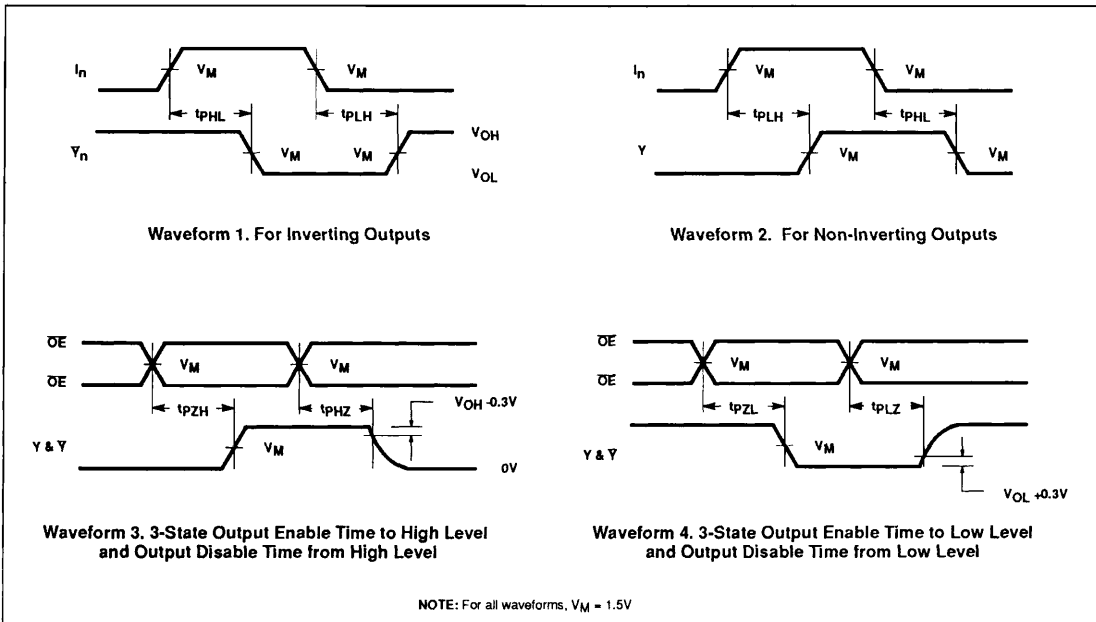

Buffers

54F240, 54F241

TEST CIRCUIT AND WAVEFORMS

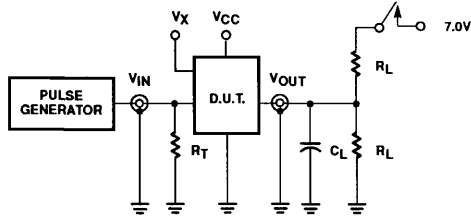

Test Circuit for 3-State Outputs

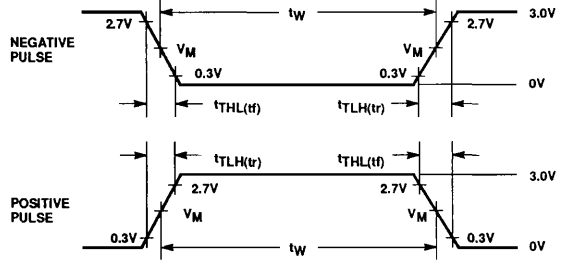

Input Pulse Definitions

SWITCH POSITION

TEST	SWITCH
t_{PLZ}	closed
t_{PZL}	closed
All other	open

INPUT PULSE CHARACTERISTICS				
Family	Rep. Rate	Pulse Width	t_{TLH}	t_{THL}
54F	1MHz	500ns	$\leq 2.5ns$	$\leq 2.5ns$

DEFINITIONS:

- R_L = Load Resistor; see AC Characteristics for value.
- C_L = Load capacitance includes jig and probe capacitance; see AC Characteristics for value.
- R_T = Termination resistance should be equal to Z_{OUT} of pulse generators.
- V_X = Unlocked pins must be held at: $\leq 0.8V$; $\geq 2.7V$ or open per Function Table.