

# ADC1213D series

Dual 12-bit ADC; 65 Msps, 80 Msps, 105 Msps or 125 Msps;  
serial JESD204A interface

Rev. 08 — 2 July 2012

Product data sheet

## 1. General description

The ADC1213D is a dual-channel 12-bit Analog-to-Digital Converter (ADC) optimized for high dynamic performance and low power at sample rates up to 125 Msps. Pipelined architecture and output error correction ensure the ADC1213D is accurate enough to guarantee zero missing codes over the entire operating range. Supplied from a 3 V source for analog and a 1.8 V source for the output driver, it embeds two serial outputs. Each lane is differential and complies with the JESD204A standard. An integrated Serial Peripheral Interface (SPI) allows the user to easily configure the ADC. A set of IC configurations is also available via the binary level control pins taken, which are used at power-up. The device also includes a programmable full-scale SPI to allow flexible input voltage range of 1 V to 2 V (peak-to-peak).

Excellent dynamic performance is maintained from the baseband to input frequencies of 170 MHz or more, making the ADC1213D ideal for use in communications, imaging, and medical applications.

## 2. Features and benefits

- SNR, 70 dBFS; SFDR, 86 dBc
- Sample rate up to 125 Msps
- Clock input divided by 2 for less jitter contribution
- 3 V, 1.8 V single supplies
- Flexible input voltage range: 1 V (p-p) to 2 V (p-p)
- Two configurable serial outputs
- Compliant with JESD204A serial transmission standard
- Pin compatible with the ADC1613D series, ADC1413D series, and ADC1113D125
- Input bandwidth, 600 MHz
- Power dissipation, 995 mW at 80 Msps
- SPI register programming
- Duty cycle stabilizer (DCS)
- High IF capability
- Offset binary, two's complement, gray code
- Power-down mode and Sleep mode
- HVQFN56 package



### 3. Applications

- Wireless and wired broadband communications
- Spectral analysis
- Ultrasound equipment
- Portable instrumentation
- Imaging systems
- Software defined radio

### 4. Ordering information

Table 1. Ordering information

Type number	Sampling frequency (MSPS)	Package		
		Name	Description	Version
ADC1213D125HN-C1	125	HVQFN56	plastic thermal enhanced very thin quad flat package; no leads; 56 terminals; body 8 × 8 × 0.85 mm	SOT684-7
ADC1213D105HN-C1	105	HVQFN56	plastic thermal enhanced very thin quad flat package; no leads; 56 terminals; body 8 × 8 × 0.85 mm	SOT684-7
ADC1213D080HN-C1	80	HVQFN56	plastic thermal enhanced very thin quad flat package; no leads; 56 terminals; body 8 × 8 × 0.85 mm	SOT684-7
ADC1213D065HN-C1	65	HVQFN56	plastic thermal enhanced very thin quad flat package; no leads; 56 terminals; body 8 × 8 × 0.85 mm	SOT684-7

5. Block diagram

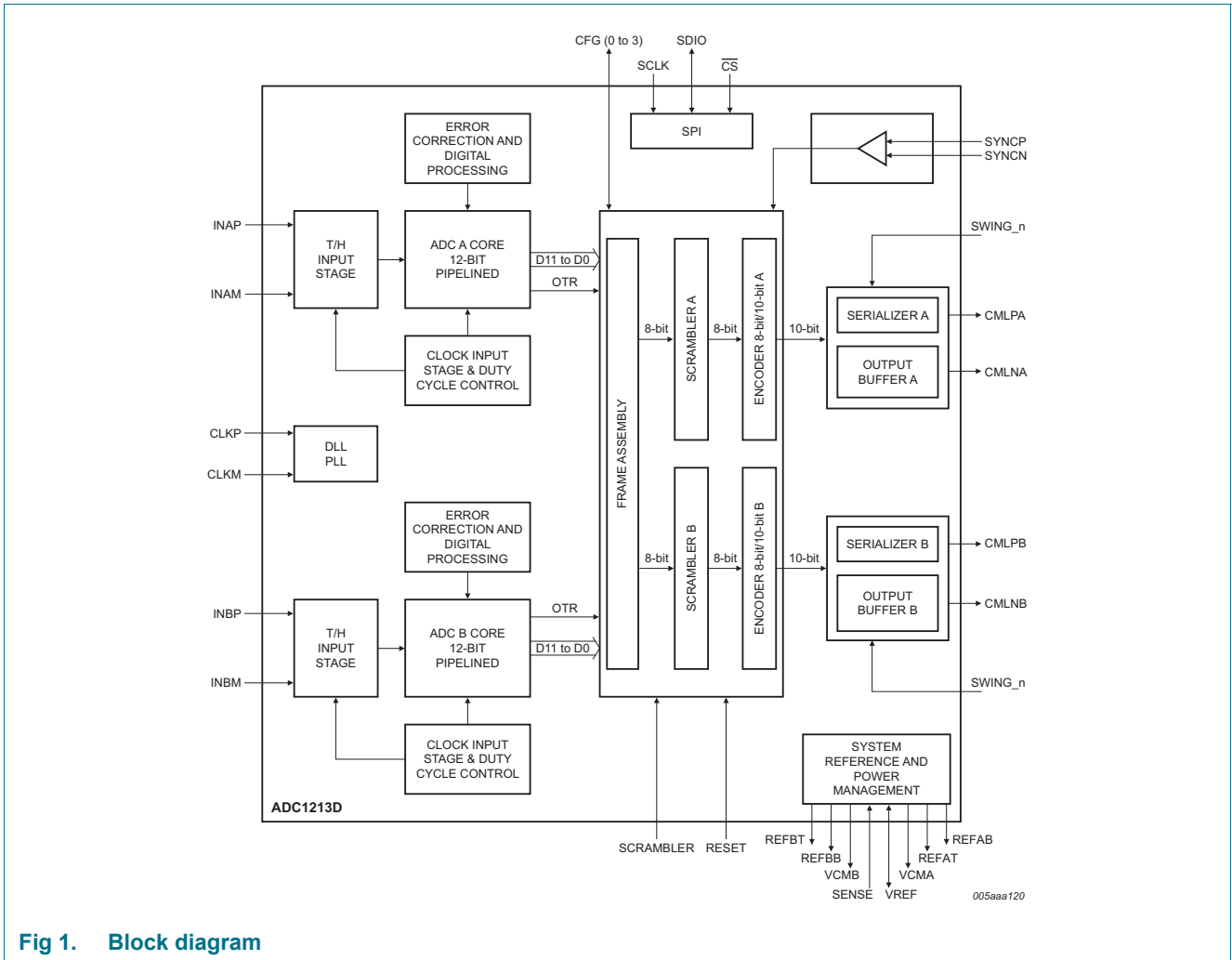

Fig 1. Block diagram

## 6. Pinning information

### 6.1 Pinning

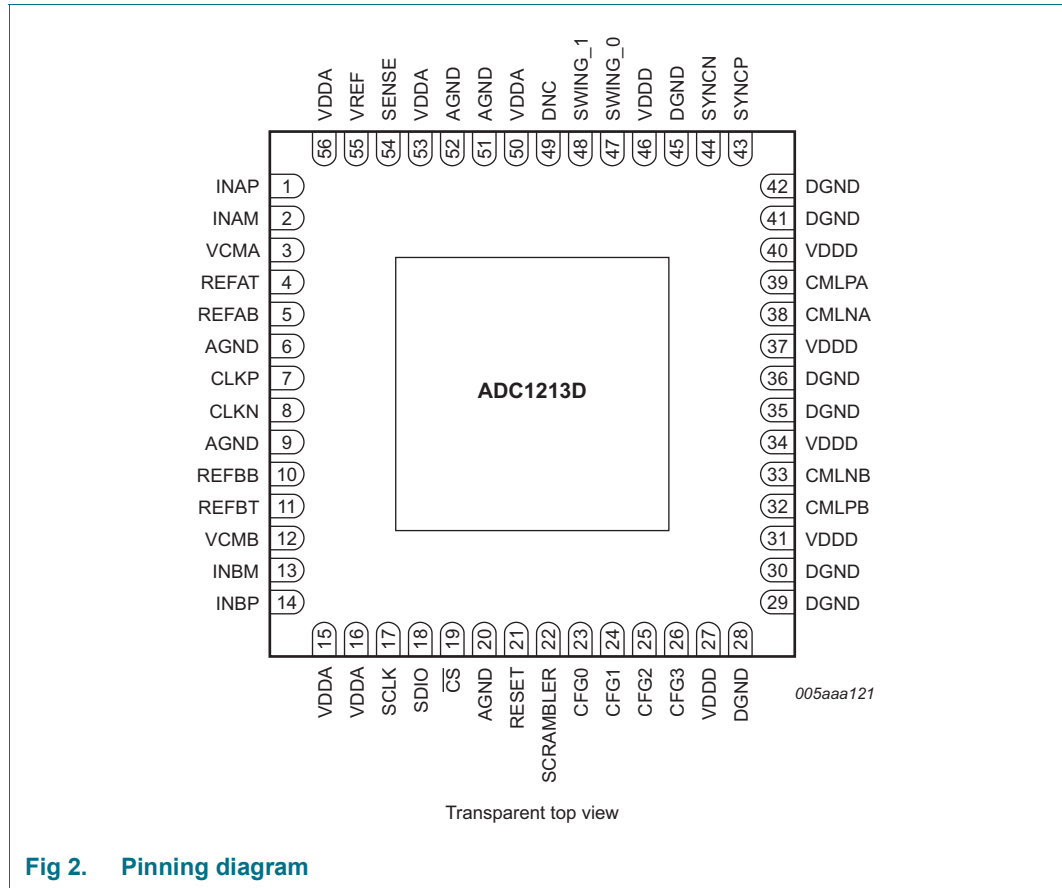

Fig 2. Pinning diagram

### 6.2 Pin description

Table 2. Pin description

Symbol	Pin	Type <sup>[1]</sup>	Description
INAP	1	I	channel A analog input
INAM	2	I	channel A complementary analog input
VCMA	3	O	channel A output common voltage
REFAT	4	O	channel A top reference
REFAB	5	O	channel A bottom reference
AGND	6	G	analog ground
CLKP	7	I	clock input
CLKM	8	I	complementary clock input
AGND	9	G	analog ground
REFBB	10	O	channel B bottom reference
REFBT	11	O	channel B top reference
VCMB	12	O	channel B output common voltage

Table 2. Pin description ...continued

Symbol	Pin	Type <sup>[1]</sup>	Description
INBM	13	I	channel B complementary analog input
INBP	14	I	channel B analog input
VDDA	15	P	analog power supply 3 V
VDDA	16	P	analog power supply 3 V
SCLK	17	I	SPI clock
SDIO	18	I/O	SPI data input/output
$\overline{\text{CS}}$	19	I	chip select
AGND	20	G	analog ground
RESET	21	I	JEDEC digital IP reset
SCRAMBLER	22	I	scrambler enable and disable
CFG0	23	I/O	see Table 28 (input) or OTRA (output) <sup>[2]</sup>
CFG1	24	I/O	see Table 28 (input) or OTRB (output) <sup>[2]</sup>
CFG2	25	I/O	see Table 28 (input)
CFG3	26	I/O	see Table 28 (input)
VDDD	27	P	digital power supply 1.8 V
DGND	28	G	digital ground
DGND	29	G	digital ground
DGND	30	G	digital ground
VDDD	31	P	digital power supply 1.8 V
CMLPB	32	O	channel B output
CMLNB	33	O	channel B complementary output
VDDD	34	P	digital power supply 1.8 V
DGND	35	G	digital ground
DGND	36	G	digital ground
VDDD	37	P	digital power supply 1.8 V
CMLNA	38	O	channel A complementary output
CMLPA	39	O	channel A output
VDDD	40	P	digital power supply 1.8 V
DGND	41	G	digital ground
DGND	42	G	digital ground
SYNCP	43	I	synchronization from FPGA
SYNCP	44	I	synchronization from FPGA
DGND	45	G	digital ground
VDDD	46	P	digital power supply 1.8 V
SWING_0	47	I	JESD204 serial buffer programmable output swing
SWING_1	48	I	JESD204 serial buffer programmable output swing
DNC	49	O	do not connect
VDDA	50	P	analog power supply 3 V
AGND	51	G	analog ground
AGND	52	G	analog ground

**Table 2. Pin description ...continued**

Symbol	Pin	Type <sup>[1]</sup>	Description
VDDA	53	P	analog power supply 3 V
SENSE	54	I	reference programming pin
VREF	55	I/O	voltage reference input/output
VDDA	56	P	analog power supply 3 V

[1] P: power supply; G: ground; I: input; O: output; I/O: input/output.

[2] OTRA stands for "OuT of Range" A. OTRB stands for "OuT of Range" B

## 7. Limiting values

**Table 3. Limiting values**

In accordance with the Absolute Maximum Rating System (IEC 60134).

Symbol	Parameter	Conditions	Min	Max	Unit
V <sub>DDA</sub>	analog supply voltage		-0.4	+4.6	V
V <sub>DDD</sub>	digital supply voltage		-0.4	+2.5	V
T <sub>stg</sub>	storage temperature		-55	+125	°C
T <sub>amb</sub>	ambient temperature		-40	+85	°C
T <sub>j</sub>	junction temperature		-	125	°C

## 8. Thermal characteristics

**Table 4. Thermal characteristics**

Symbol	Parameter	Conditions	Typ	Unit
R <sub>th(j-a)</sub>	thermal resistance from junction to ambient		[1] 17.8	K/W
R <sub>th(j-c)</sub>	thermal resistance from junction to case		[1] 6.8	K/W

[1] Value for six layers board in still air with a minimum of 25 thermal vias.

## 9. Static characteristics

**Table 5. Static characteristics<sup>[1]</sup>**

Symbol	Parameter	Conditions	Min	Typ	Max	Unit
<b>Supplies</b>						
V <sub>DDA</sub>	analog supply voltage		2.85	3.0	3.4	V
V <sub>DDD</sub>	digital supply voltage		1.65	1.8	1.95	V
I <sub>DDA</sub>	analog supply current	f <sub>clk</sub> = 125 Msps; f <sub>i</sub> = 70 MHz	-	343	-	mA
I <sub>DDD</sub>	digital supply current	f <sub>clk</sub> = 125 Msps; f <sub>i</sub> = 70 MHz	-	150	-	mA
P <sub>tot</sub>	total power dissipation	f <sub>clk</sub> = 125 Msps	-	1270	-	mW
		f <sub>clk</sub> = 105 Msps	-	1150	-	mW
		f <sub>clk</sub> = 80 Msps	-	995	-	mW
		f <sub>clk</sub> = 65 Msps	-	885	-	mW

Table 5. Static characteristics<sup>[1]</sup> ...continued

Symbol	Parameter	Conditions	Min	Typ	Max	Unit
P	power dissipation	Power-down mode	-	30	-	mW
		Standby mode	-	200	-	mW
<b>Clock inputs: pins CLKP and CLKM (AC-coupled)</b>						
<b>Low-Voltage Positive Emitter-Coupled Logic (LVPECL)</b>						
$V_{i(\text{clk})\text{dif}}$	differential clock input voltage	peak-to-peak	-	$\pm 0.8$	-	V
<b>SINE</b>						
$V_{i(\text{clk})\text{dif}}$	differential clock input voltage	peak-to-peak	$\pm 0.8$	$\pm 1.5$	-	V
<b>Low Voltage Complementary Metal Oxide Semiconductor (LVCMOS)</b>						
$V_{iL}$	LOW-level input voltage		-	-	$0.3V_{DDA}$	V
$V_{iH}$	HIGH-level input voltage		$0.7V_{DDA}$	-	-	V
<b>Logic inputs: Power-down: pins CFG0 to CFG3, SCRAMBLER, SWING_0, SWING_1, and RESET</b>						
$V_{iL}$	LOW-level input voltage		-	0	-	V
$V_{iH}$	HIGH-level input voltage		-	$0.66V_{DDD}$	-	V
$I_{iL}$	LOW-level input current		-6	-	+6	$\mu\text{A}$
$I_{iH}$	HIGH-level input current		-30	-	+30	$\mu\text{A}$
<b>SPI: pins CS, SDIO, and SCLK</b>						
$V_{iL}$	LOW-level input voltage		0	-	$0.3V_{DDA}$	V
$V_{iH}$	HIGH-level input voltage		$0.7V_{DDA}$	-	$V_{DDA}$	V
$I_{iL}$	LOW-level input current		-10	-	+10	$\mu\text{A}$
$I_{iH}$	HIGH-level input current		-50	-	+50	$\mu\text{A}$
$C_i$	input capacitance		-	4	-	pF
<b>Analog inputs: pins INAP, INAM, INBP, and INBM</b>						
$I_i$	input current	track mode	-5	-	+5	$\mu\text{A}$
$R_i$	input resistance	track mode	-	15	-	$\Omega$
$C_i$	input capacitance	track mode	-	5	-	pF
$V_{i(\text{cm})}$	common-mode input voltage	track mode	0.9	1.5	2	V
$B_i$	input bandwidth		-	600	-	MHz
$V_{i(\text{dif})}$	differential input voltage	peak-to-peak	1	-	2	V
<b>Voltage controlled regulator output: pins VCMA and VCMB</b>						
$V_{O(\text{cm})}$	common-mode output voltage		-	$V_{DDA} / 2$	-	V
$I_{O(\text{cm})}$	common-mode output current		-	4	-	mA

Table 5. Static characteristics<sup>[1]</sup> ...continued

Symbol	Parameter	Conditions	Min	Typ	Max	Unit
<b>Reference voltage input/output: pin VREF</b>						
V <sub>VREF</sub>	voltage on pin VREF	output	0.5	-	1	V
		input	0.5	-	1	V
<b>Reference mode selection: pin SENSE</b>						
V <sub>SENSE</sub>	voltage on pin SENSE		-	pin AGND; V <sub>VREF</sub> ; V <sub>DDA</sub>	-	V
<b>Data outputs: pins CMLPA, CMLNA</b>						
Output levels, V <sub>DDD</sub> = 1.8 V; SWING_SEL[2:0] = 000						
V <sub>OL</sub>	LOW-level output voltage	DC coupled; output	-	1.5	-	V
		AC coupled	-	1.35	-	V
V <sub>OH</sub>	HIGH-level output voltage	DC coupled; output	-	1.8	-	V
		AC coupled	-	1.65	-	V
Output levels, V <sub>DDD</sub> = 1.8 V; SWING_SEL[2:0] = 001						
V <sub>OL</sub>	LOW-level output voltage	DC coupled; output	-	1.45	-	V
		AC coupled	-	1.275	-	V
V <sub>OH</sub>	HIGH-level output voltage	DC coupled; output	-	1.8	-	V
		AC coupled	-	1.625	-	V
Output levels, V <sub>DDD</sub> = 1.8 V; SWING_SEL[2:0] = 010						
V <sub>OL</sub>	LOW-level output voltage	DC coupled; output	-	1.4	-	V
		AC coupled	-	1.2	-	V
V <sub>OH</sub>	HIGH-level output voltage	DC coupled; output	-	1.8	-	V
		AC coupled	-	1.6	-	V
Output levels, V <sub>DDD</sub> = 1.8 V; SWING_SEL[2:0] = 011						
V <sub>OL</sub>	LOW-level output voltage	DC coupled; output	-	1.35	-	V
		AC coupled	-	1.125	-	V
V <sub>OH</sub>	HIGH-level output voltage	DC coupled; output	-	1.8	-	V
		AC coupled	-	1.575	-	V
Output levels, V <sub>DDD</sub> = 1.8 V; SWING_SEL[2:0] = 100						
V <sub>OL</sub>	LOW-level output voltage	DC coupled; output	-	1.3	-	V
		AC coupled	-	1.05	-	V
V <sub>OH</sub>	HIGH-level output voltage	DC coupled; output	-	1.8	-	V
		AC coupled	-	1.55	-	V
<b>Serial configuration: pins SYNCCP, SYNCCN</b>						
V <sub>IL</sub>	LOW-level input voltage	differential; input	-	0.95	-	V
V <sub>IH</sub>	HIGH-level input voltage	differential; input	-	1.47	-	V
<b>Accuracy</b>						
INL	integral non-linearity		-5	-	+5	LSB
DNL	differential non-linearity	guaranteed no missing codes	-0.95	±0.5	+0.95	LSB
E <sub>offset</sub>	offset error		-	±2	-	mV
E <sub>G</sub>	gain error	full-scale	-	± 0.5	-	%



**Table 5.** Static characteristics<sup>[1]</sup> ...continued

Symbol	Parameter	Conditions	Min	Typ	Max	Unit
$M_{G(CTC)}$	channel-to-channel gain matching		-	1.1	-	%
<b>Supply</b>						
PSRR	power supply rejection ratio	200 mV (p-p) on pin VDDA; $f_i = DC$	-	-54	-	dB

[1] Typical values measured at  $V_{DDA} = 3 V$ ,  $V_{DDD} = 1.8 V$ ,  $T_{amb} = 25 ^\circ C$ . Minimum and maximum values are across the full temperature range  $T_{amb} = -40 ^\circ C$  to  $+85 ^\circ C$  at  $V_{DDA} = 3 V$ ,  $V_{DDD} = 1.8 V$ ;  $V_i$  (INAP, INBP) –  $V_i$  (INAM, INBM) = -1 dBFS; internal reference mode; 100  $\Omega$  differential applied to serial outputs; unless otherwise specified.

# 10. Dynamic characteristics

## 10.1 Dynamic characteristics

Table 6. Dynamic characteristics<sup>[1]</sup>

Symbol	Parameter	Conditions	ADC1213D065		ADC1213D080		ADC1213D105		ADC1213D125		Unit				
			Min	Typ	Max	Min	Typ	Max	Min	Typ		Max			
<b>Analog signal processing</b>															
$\alpha_{2H}$	second harmonic level	$f_i = 3$ MHz	-	87	-	-	87	-	-	86	-	-	88	-	dBc
		$f_i = 30$ MHz	-	86	-	-	86	-	-	86	-	-	87	-	dBc
		$f_i = 70$ MHz	-	85	-	-	85	-	-	84	-	-	85	-	dBc
		$f_i = 170$ MHz	-	82	-	-	82	-	-	81	-	-	83	-	dBc
$\alpha_{3H}$	third harmonic level	$f_i = 3$ MHz	-	86	-	-	86	-	-	85	-	-	87	-	dBc
		$f_i = 30$ MHz	-	85	-	-	85	-	-	85	-	-	86	-	dBc
		$f_i = 70$ MHz	-	84	-	-	84	-	-	83	-	-	84	-	dBc
		$f_i = 170$ MHz	-	81	-	-	81	-	-	80	-	-	82	-	dBc
THD	total harmonic distortion	$f_i = 3$ MHz	-	83	-	-	83	-	-	82	-	-	84	-	dBc
		$f_i = 30$ MHz	-	82	-	-	82	-	-	82	-	-	83	-	dBc
		$f_i = 70$ MHz	-	81	-	-	81	-	-	80	-	-	81	-	dBc
		$f_i = 170$ MHz	-	78	-	-	78	-	-	77	-	-	79	-	dBc
ENOB	effective number of bits	$f_i = 3$ MHz	-	11.3	-	-	11.3	-	-	11.3	-	-	11.3	-	bits
		$f_i = 30$ MHz	-	11.3	-	-	11.3	-	-	11.3	-	-	11.2	-	bits
		$f_i = 70$ MHz	-	11.2	-	-	11.2	-	-	11.2	-	-	11.2	-	bits
		$f_i = 170$ MHz	-	11.1	-	-	11.1	-	-	11.1	-	-	11.1	-	bits
SNR	signal-to-noise ratio	$f_i = 3$ MHz	-	70.0	-	-	69.9	-	-	69.8	-	-	69.6	-	dBFS
		$f_i = 30$ MHz	-	69.5	-	-	69.5	-	-	69.5	-	-	69.4	-	dBFS
		$f_i = 70$ MHz	-	69.2	-	-	69.2	-	-	69.1	-	-	69.0	-	dBFS
		$f_i = 170$ MHz	-	68.8	-	-	68.8	-	-	68.7	-	-	68.6	-	dBFS
SFDR	spurious-free dynamic range	$f_i = 3$ MHz	-	86	-	-	86	-	-	85	-	-	87	-	dBc
		$f_i = 30$ MHz	-	85	-	-	85	-	-	85	-	-	86	-	dBc
		$f_i = 70$ MHz	-	84	-	-	84	-	-	83	-	-	84	-	dBc
		$f_i = 170$ MHz	-	81	-	-	81	-	-	80	-	-	82	-	dBc

Table 6. Dynamic characteristics<sup>[1]</sup> ... continued

Symbol	Parameter	Conditions	ADC1213D065			ADC1213D080			ADC1213D105			ADC1213D125			Unit
			Min	Typ	Max	Min	Typ	Max	Min	Typ	Max	Min	Typ	Max	
IMD	intermodulation distortion	$f_i = 3 \text{ MHz}$	-	89	-	-	89	-	-	88	-	-	89	-	dBc
		$f_i = 30 \text{ MHz}$	-	88	-	-	88	-	-	88	-	-	88	-	dBc
		$f_i = 70 \text{ MHz}$	-	87	-	-	87	-	-	86	-	-	86	-	dBc
		$f_i = 170 \text{ MHz}$	-	84	-	-	85	-	-	83	-	-	84	-	dBc
$\alpha_{ct(ch)}$	channel crosstalk	$f_i = 70 \text{ MHz}$	-	100	-	-	100	-	-	100	-	-	100	-	dBc

[1] Typical values measured at  $V_{DDA} = 3 \text{ V}$ ,  $V_{DDD} = 1.8 \text{ V}$ ,  $T_{amb} = 25 \text{ }^\circ\text{C}$ . Minimum and maximum values are across the full temperature range  $T_{amb} = -40 \text{ }^\circ\text{C}$  to  $+85 \text{ }^\circ\text{C}$  at  $V_{DDA} = 3 \text{ V}$ ,  $V_{DDD} = 1.8 \text{ V}$ ;  $V_i$  (INAP, INBP) –  $V_i$  (INAM, INBM) =  $-1 \text{ dBFS}$ ; internal reference mode;  $100 \text{ } \Omega$  differential applied to serial outputs; unless otherwise specified.

## 10.2 Clock and digital output timing

Table 7. Clock and digital output characteristics<sup>[1]</sup>

Symbol	Parameter	Conditions	ADC1213D065			ADC1213D080			ADC1213D105			ADC1213D125			Unit
			Min	Typ	Max	Min	Typ	Max	Min	Typ	Max	Min	Typ	Max	
$f_{clk}$	clock frequency		45	-	65	60	-	80	75	-	105	100	-	125	Msps
$t_{lat(data)}$	data latency time	clock cycles	307	-	850	250	-	283	190	-	226	160	-	170	ns
$\delta_{clk}$	clock duty cycle	DCS_EN = logic 1	30	50	70	30	50	70	30	50	70	30	50	70	%
		DCS_EN = logic 0	45	50	55	45	50	55	45	50	55	45	50	55	%
$t_{d(s)}$	sampling delay time		-	0.8	-	-	0.8	-	-	0.8	-	-	0.8	-	ns
$t_{wake}$	wake-up time		-	76	-	-	76	-	-	76	-	-	76	-	$\mu\text{s}$

[1] Typical values measured at  $V_{DDA} = 3 \text{ V}$ ,  $V_{DDD} = 1.8 \text{ V}$ ,  $T_{amb} = 25 \text{ }^\circ\text{C}$ . Minimum and maximum values are across the full temperature range  $T_{amb} = -40 \text{ }^\circ\text{C}$  to  $+85 \text{ }^\circ\text{C}$  at  $V_{DDA} = 3 \text{ V}$ ,  $V_{DDD} = 1.8 \text{ V}$ ;  $V_i$  (INAP, INBP) –  $V_i$  (INAM, INBM) =  $-1 \text{ dBFS}$ ; internal reference mode;  $100 \text{ } \Omega$  differential applied to serial outputs; unless otherwise specified.

### 10.3 Serial output timing

The eye diagram of the serial output is shown in Figure 3 and Figure 4. Test conditions are:

- 3.125 Gbps data rate
- $T_{amb} = 25\text{ }^{\circ}\text{C}$
- DC coupling with two different receiver common-mode voltages

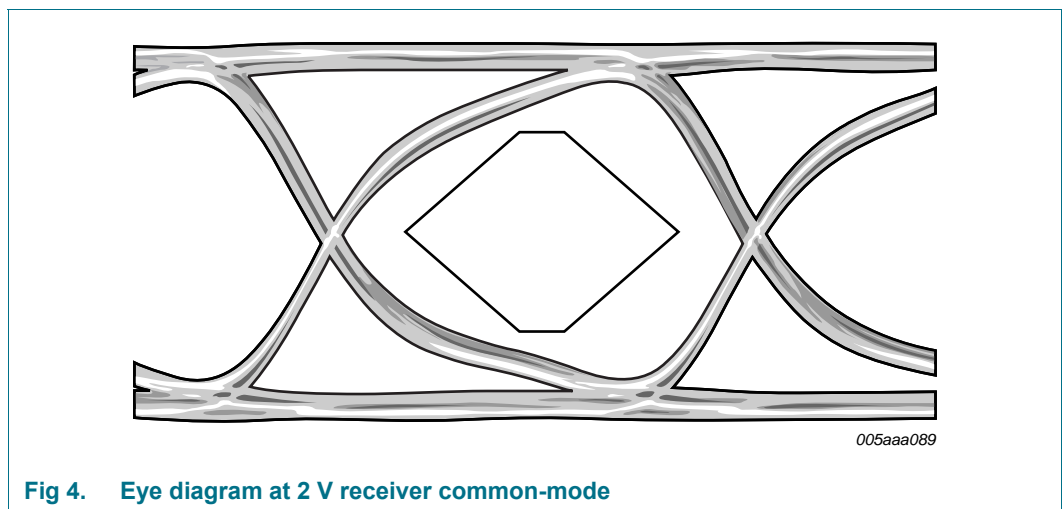
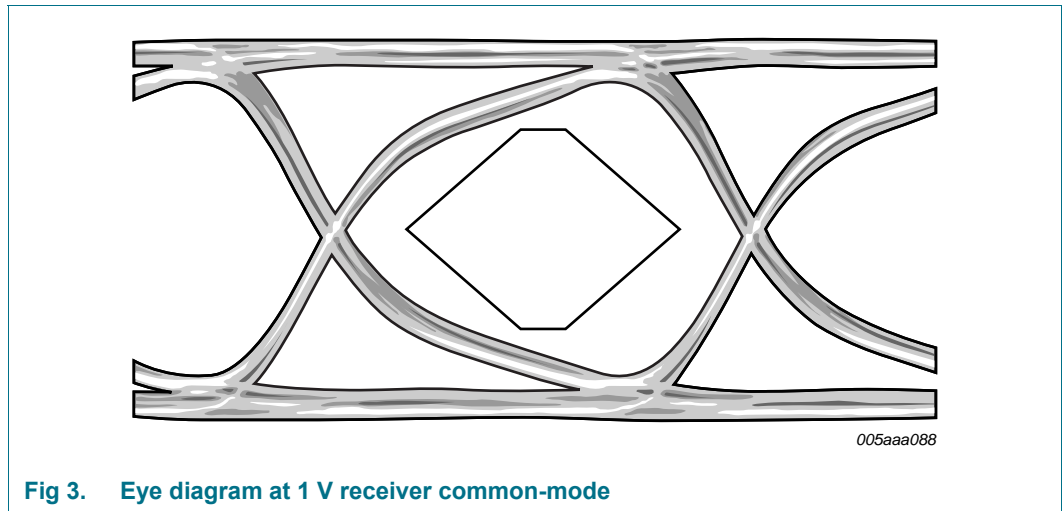

### 10.4 SPI timing

Table 8. SPI timing characteristics [1]

Symbol	Parameter	Conditions	Min	Typ	Max	Unit
$t_{w(SCLK)}$	SCLK pulse width		-	40	-	ns
$t_{w(SCLKH)}$	SCLK HIGH pulse width		-	16	-	ns
$t_{w(SCLKL)}$	SCLK LOW pulse width		-	16	-	ns
$t_{su}$	set-up time	data to SCLK H	-	5	-	ns
		$\overline{CS}$ to SCLK H	-	5	-	ns
$t_h$	hold time	data to SCLK H	-	2	-	ns
		$\overline{CS}$ to SCLK H	-	2	-	ns
$f_{clk(max)}$	maximum clock frequency		-	25	-	MHz

[1] Typical values measured at  $V_{DDA} = 3\text{ V}$ ,  $V_{DDD} = 1.8\text{ V}$ ,  $T_{amb} = 25\text{ }^\circ\text{C}$ . Minimum and maximum values are across the full temperature range  $T_{amb} = -40\text{ }^\circ\text{C}$  to  $+85\text{ }^\circ\text{C}$  at  $V_{DDA} = 3\text{ V}$ ,  $V_{DDD} = 1.8\text{ V}$ ;  $V_I$  (INAP, INBP) –  $V_I$  (INAM, INBM) = -1 dBFS; internal reference mode; 100  $\Omega$  differential applied to serial outputs; unless otherwise specified.

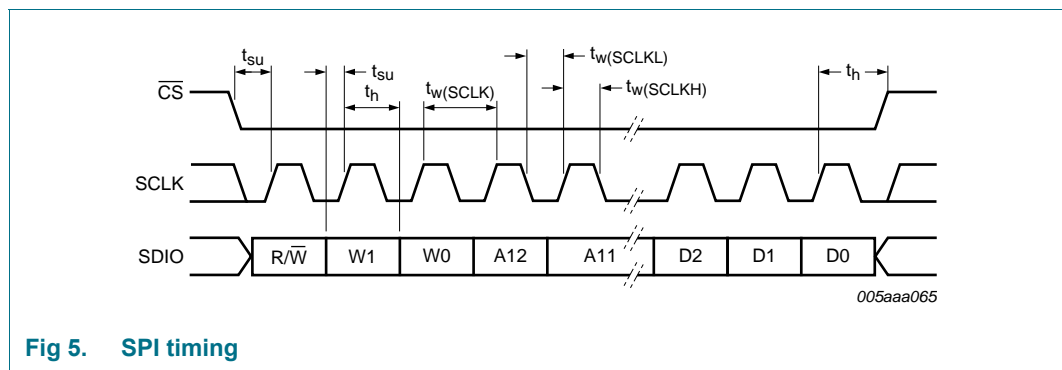

Fig 5. SPI timing

## 11. Application information

### 11.1 Analog inputs

#### 11.1.1 Input stage description

The analog input of the ADC1213D supports a differential or a single-ended input drive. Optimal performance is achieved using differential inputs with the common-mode input voltage ( $V_{I(cm)}$ ) on pins INxP and INxM set to  $0.5V_{DDA}$ .

The full-scale analog input voltage range is configurable between 1 V (p-p) and 2 V (p-p) via a programmable internal reference (see Section 11.2 and Table 21).

Figure 6 shows the equivalent circuit of the sample-and-hold input stage, including ElectroStatic Discharge (ESD) protection and circuit and package parasitics.

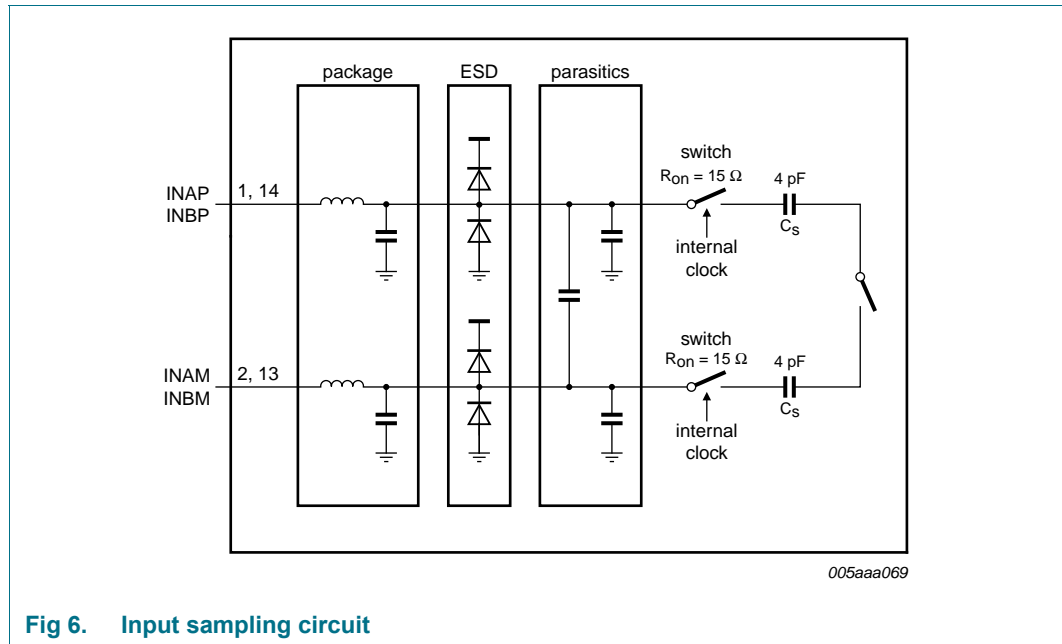

Fig 6. Input sampling circuit

The sample phase occurs when the internal clock (derived from the clock signal on pin CLKP/CLKM) is HIGH. The voltage is then held on the sampling capacitors. When the clock signal goes LOW, the stage enters the hold phase and the voltage information is transmitted to the ADC core.

11.1.2 Anti-kickback circuitry

Anti-kickback circuitry (RC filter in Figure 7) is needed to counteract the effects of a charge injection generated by the sampling capacitance.

The RC filter is also used to filter noise from the signal before it reaches the sampling stage. The value of the capacitor should be chosen to maximize noise attenuation without degrading the settling time excessively.

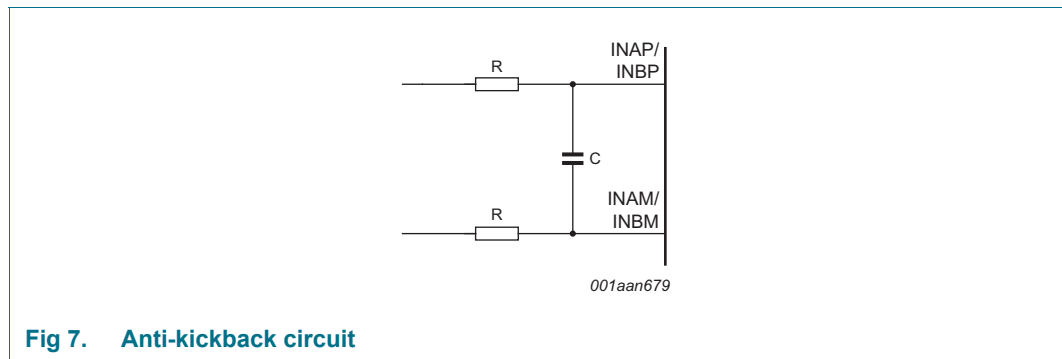

Fig 7. Anti-kickback circuit

The component values are determined by the input frequency and should be selected so as not to affect the input bandwidth.

Table 9. RC coupling versus input frequency - typical values

Input frequency (MHz)	Resistance ( $\Omega$ )	Capacitance (pF)
3	25	12
70	12	8
170	12	8

11.1.3 Transformer

The configuration of the transformer circuit is determined by the input frequency. The configuration shown in Figure 8 would be suitable for a baseband application.

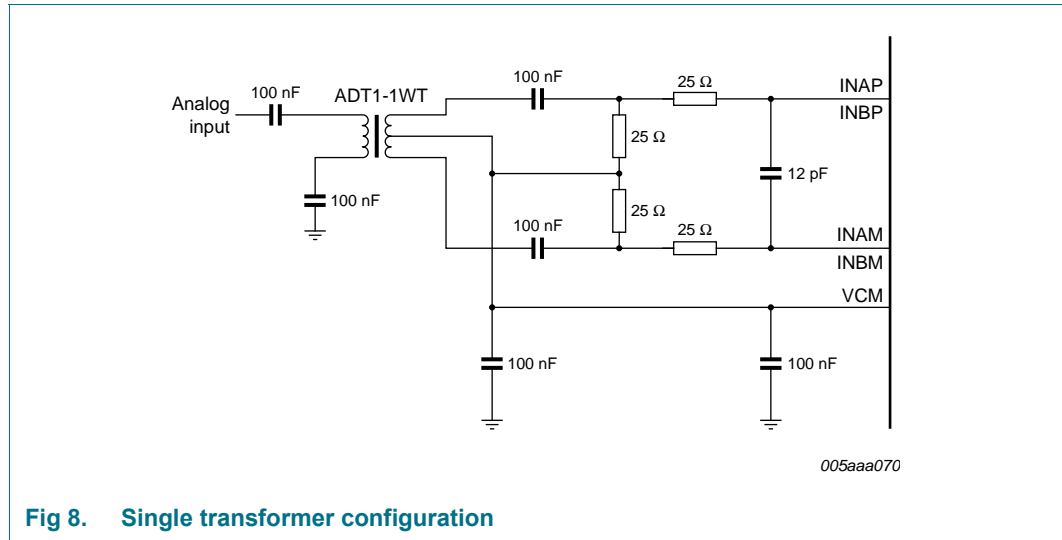

Fig 8. Single transformer configuration

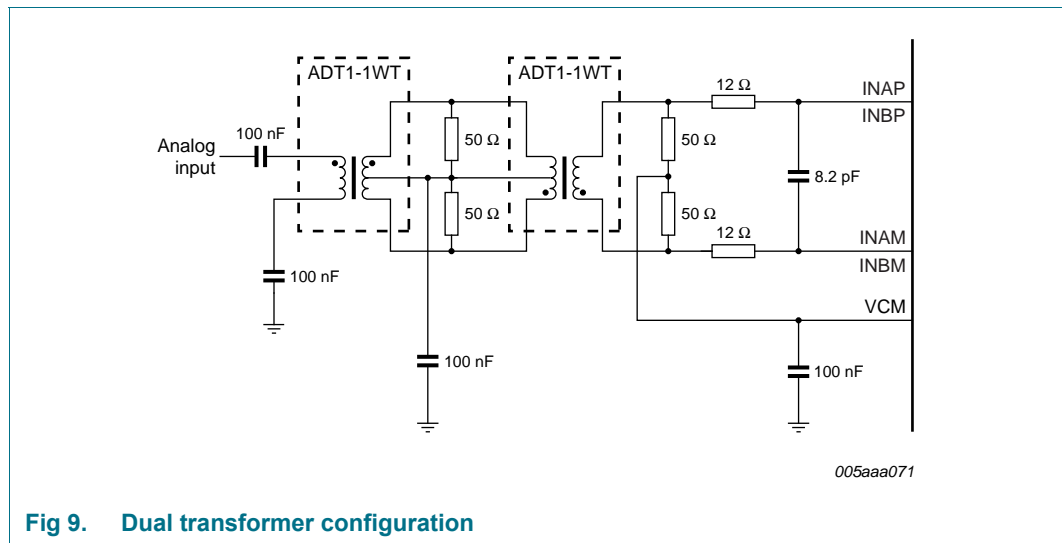

Fig 9. Dual transformer configuration

The configuration shown in Figure 9 is recommended for high frequency applications. In both cases, the choice of transformer is a compromise between cost and performance.

## 11.2 System reference and power management

### 11.2.1 Internal/external reference

The ADC1213D has a stable and accurate built-in internal reference voltage to adjust the ADC full-scale. This reference voltage can be set internally via SPI or with pin VREF and SENSE (see Figure 11 to Figure 14), in 1 dB steps between 0 dB and -6 dB, via SPI control bits INTREF[2:0] (when bit INTREF\_EN = logic 1; see Table 21). The equivalent reference circuit is shown in Figure 10. An external reference is also possible by providing a voltage on pin VREF as described in Figure 13.

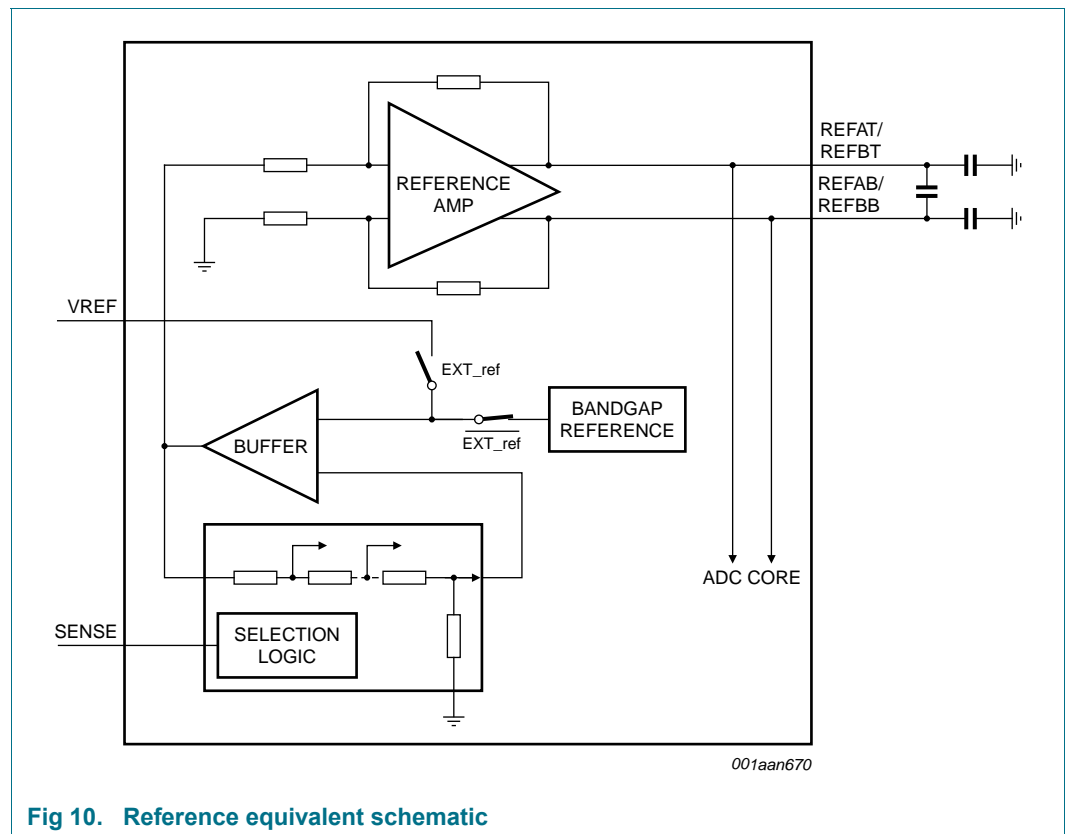

Fig 10. Reference equivalent schematic

If bit INTREF\_EN is set to logic 0, the reference voltage is determined either internally or externally as detailed in Table 10.

Table 10. Reference modes

Mode	SPI bit, "Internal reference"	SENSE pin	VREF pin	Full-scale (V (p-p))
Internal (Figure 11)	0	GND	330 pF capacitor to GND	2
Internal (Figure 12)	0	VREF pin = SENSE pin and 330 pF capacitor to GND		1
External (Figure 13)	0	V <sub>DDA</sub>	external voltage from 0.5 V to 1 V	1 to 2
Internal, SPI mode (Figure 14)	1	VREF pin = SENSE pin and 330 pF capacitor to GND		1 to 2



Figure 11 to Figure 14 illustrate how to connect the SENSE and VREF pins to select the required reference voltage source.

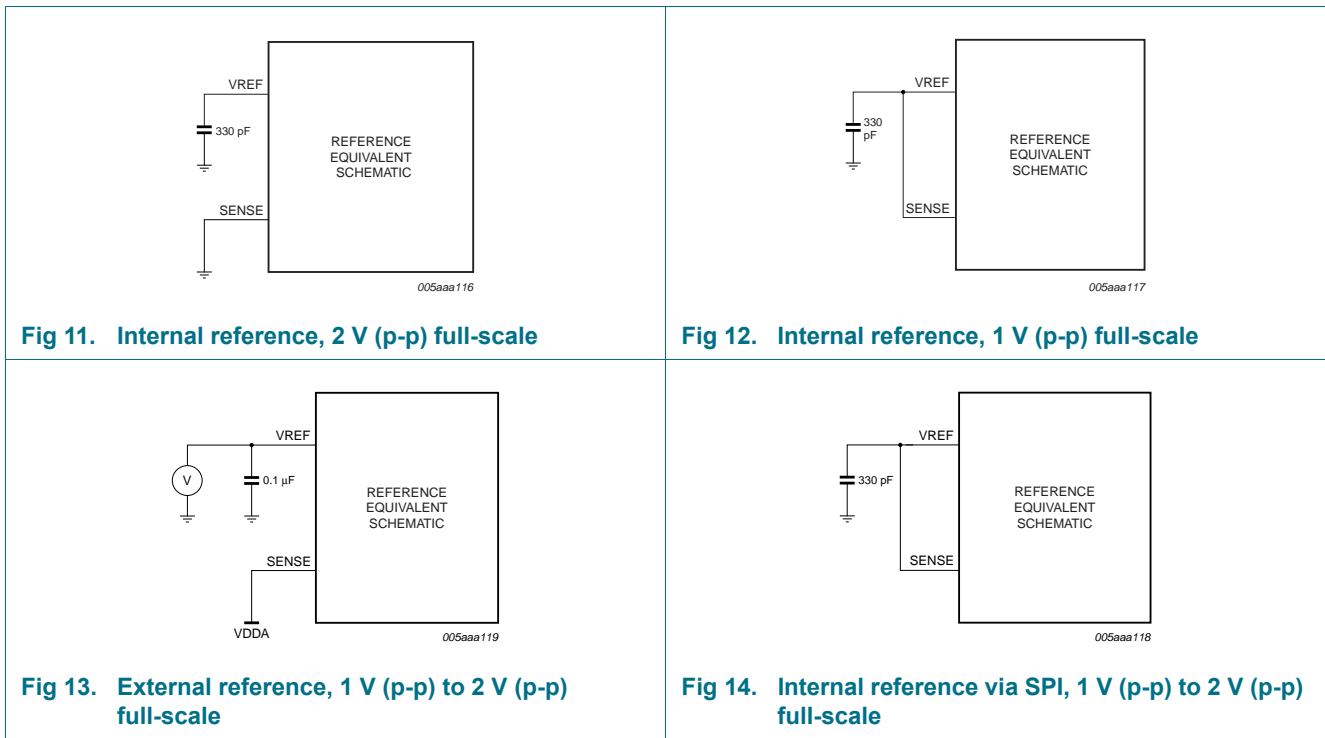

### 11.2.2 Programmable full-scale

The full-scale is programmable between 1 V (p-p) to 2 V (p-p) (see Table 11).

Table 11. Programmable full-scale

INTREF[2:0]	Level (dB)	Full-scale (V (p-p))
000	0	2
001	-1	1.78
010	-2	1.59
011	-3	1.42
100	-4	1.26
101	-5	1.12
110	-6	1
111	not used	x

### 11.2.3 Common-mode output voltage (V<sub>O(cm)</sub>)

An 0.1 μF filter capacitor should be connected between the pins VCMA and VCMB and ground to ensure a low-noise common-mode output voltage. When AC-coupled, these pins can be used to set the common-mode reference for the analog inputs, for instance via a transformer middle point.

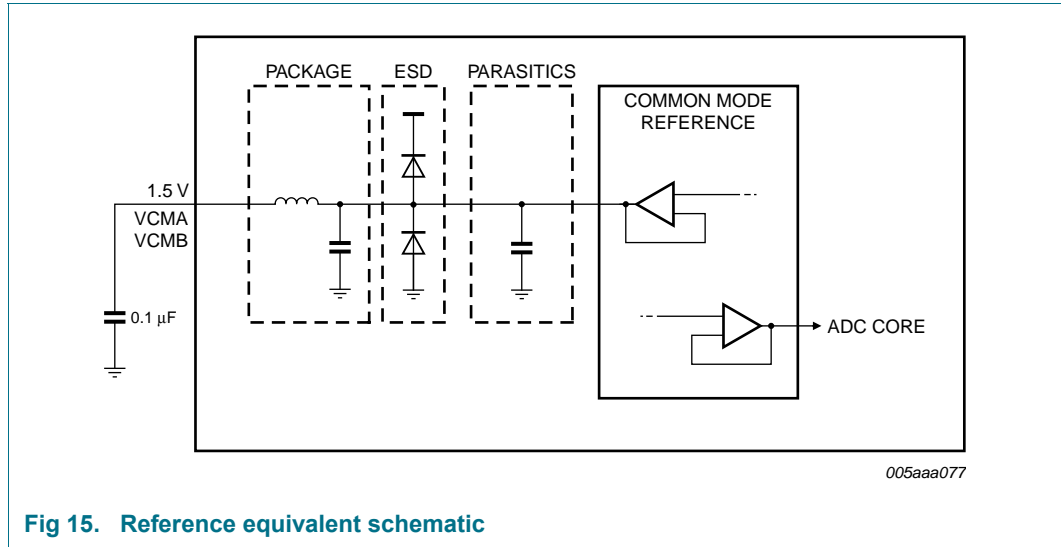

Fig 15. Reference equivalent schematic

### 11.2.4 Biasing

The common-mode output voltage,  $V_{O(cm)}$ , should be set externally to 1.5 V (typical). The common-mode input voltage,  $V_{I(cm)}$ , at the inputs to the sample-and-hold stage (pins INAM, INBM, INAP, and INBP) must be between 0.9 V and 2 V for optimal performance.

## 11.3 Clock input

### 11.3.1 Drive modes

The ADC1213D can be driven differentially (LVPECL). It can also be driven by a single-ended Low Voltage Complementary Metal Oxide Semiconductor (LVCMOS) signal connected to pin CLKP (pin CLKM should be connected to ground via a capacitor) or pin CLKM (pin CLKP should be connected to ground via a capacitor).

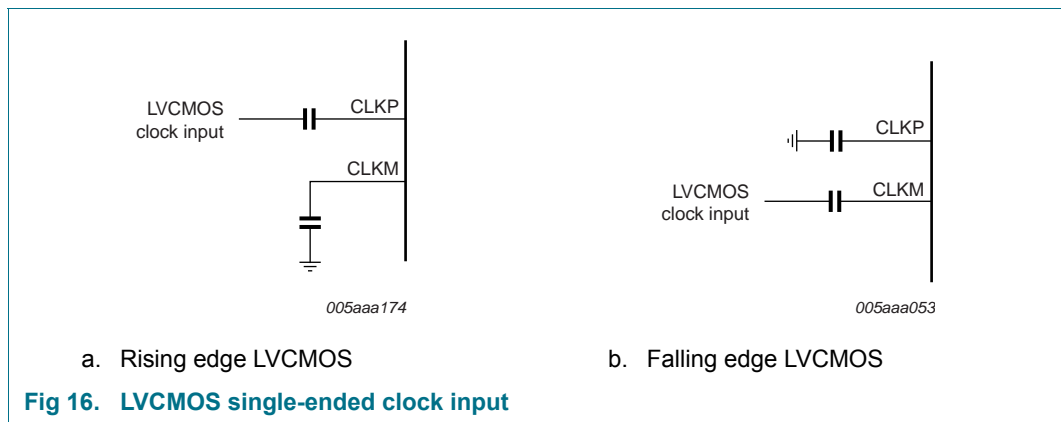
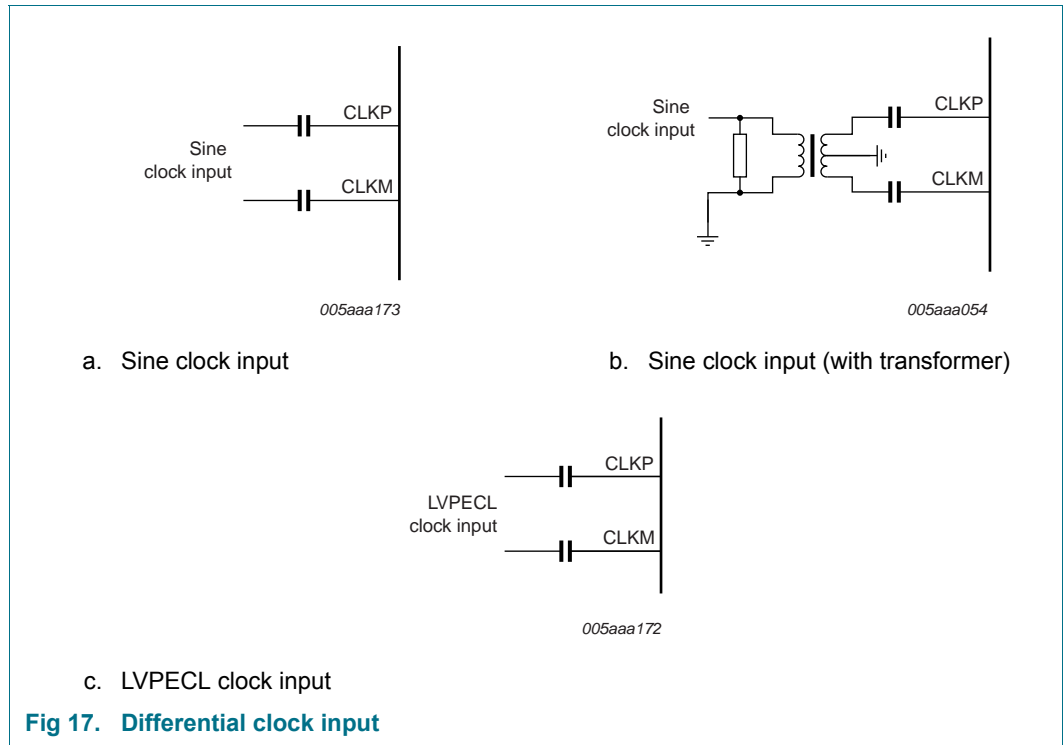
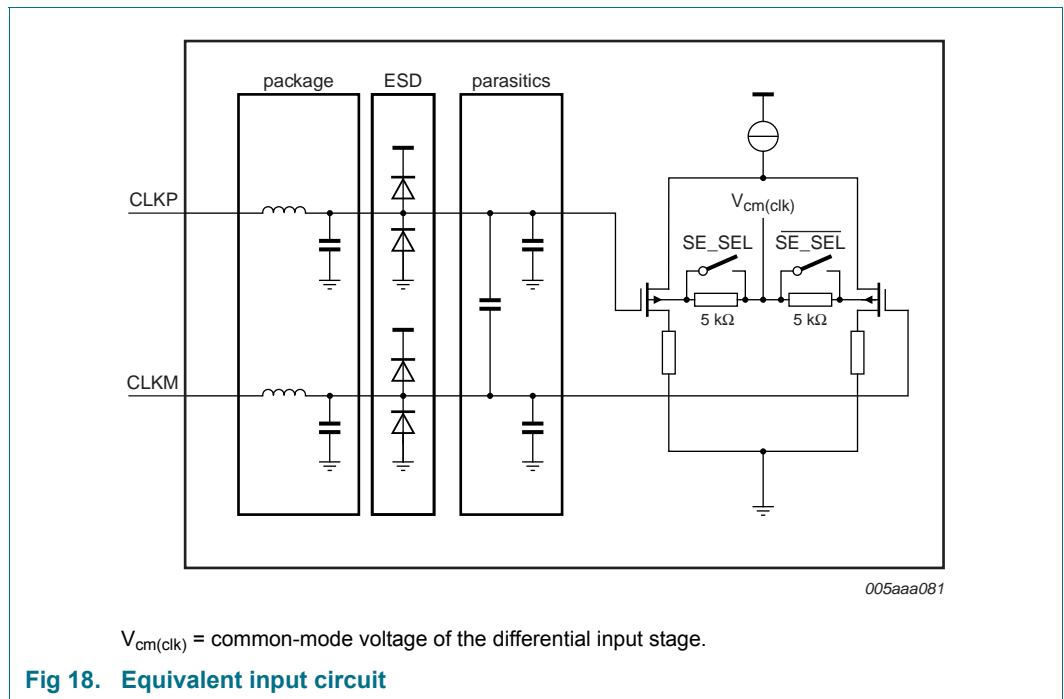

Fig 16. LVCMOS single-ended clock input



### 11.3.2 Equivalent input circuit

The equivalent circuit of the input clock buffer is shown in Figure 18. The common-mode voltage of the differential input stage is set via 5 kΩ internal resistors.



Single-ended or differential clock inputs can be selected via the SPI (see Table 20). If single-ended is selected, the input pin (CLKM or CLKP) is selected via control bit SE\_SEL.

If single-ended is implemented without setting bit SE\_SEL accordingly, the unused pin should be connected to ground via a capacitor.

### 11.3.3 Clock input divider

The ADC1413D contains an input clock divider that divides the incoming clock by a factor of 2 (when bit CLKDIV2\_SEL = logic 1; see Table 20). This feature allows the user to deliver a higher clock frequency with better jitter performance, leading to a better SNR result once acquisition has been performed.

### 11.3.4 Duty cycle stabilizer

The duty cycle stabilizer can improve the overall performance of the ADC by compensating the input clock signal duty cycle. When the duty cycle stabilizer is active (bit DCS\_EN = logic 1; see Table 20), the circuit can handle signals with duty cycles of between 30 % and 70 % (typical). When the duty cycle stabilizer is disabled (DCS\_EN = logic 0), the input clock signal should have a duty cycle of between 45 % and 55 %.

Table 12. Duty cycle stabilizer

Bit DCS_EN	Description
0	duty cycle stabilizer disable
1	duty cycle stabilizer enable

## 11.4 Digital outputs

### 11.4.1 Serial output equivalent circuit

The JESD204A standard specifies that if the receiver and the transmitter are DC-coupled, both must be fed from the same supply.

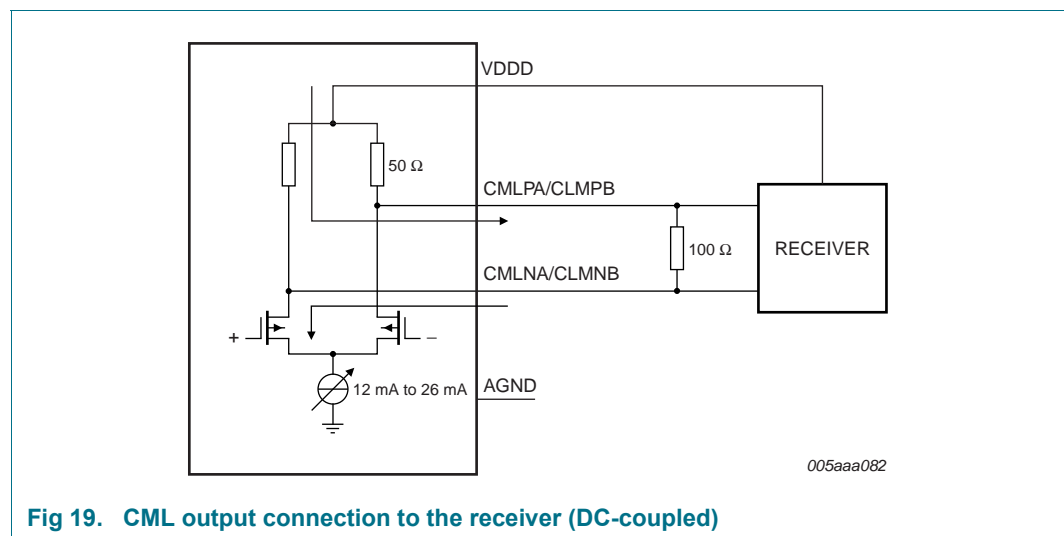

Fig 19. CML output connection to the receiver (DC-coupled)

The output should be terminated when 100 Ω (typical) is reached at the receiver side.

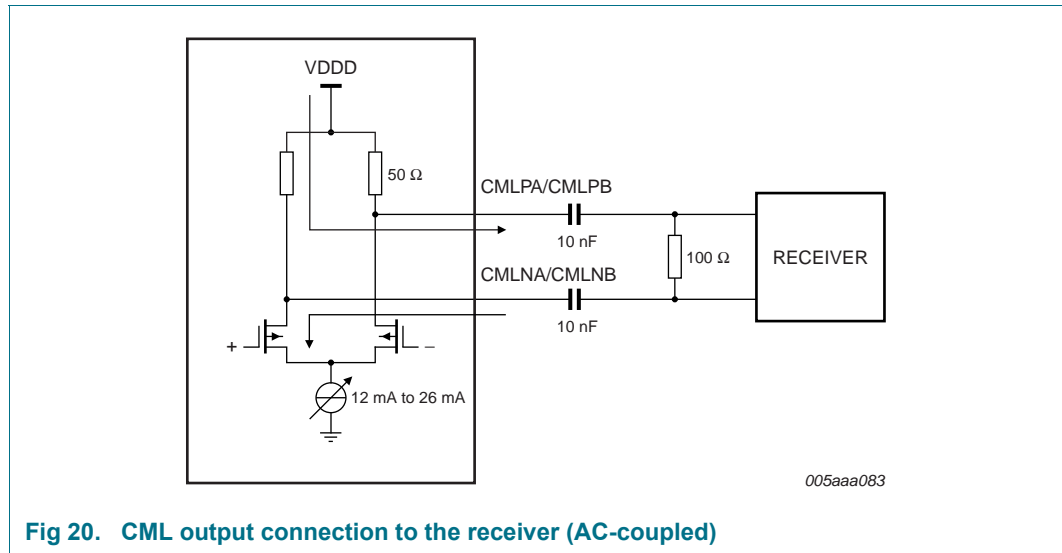

Fig 20. CML output connection to the receiver (AC-coupled)

### 11.5 JESD204A serializer

For more information about the JESD204A standard refer to the JEDEC web site.

#### 11.5.1 Digital JESD204A formatter

The block placed after the ADC cores is used to implement all functionalities of the JESD204A standard. This ensures signal integrity and guarantees the clock and the data recovery at the receiver side.

The block is highly parameterized and can be configured in various ways depending on the sampling frequency and the number of lanes used.

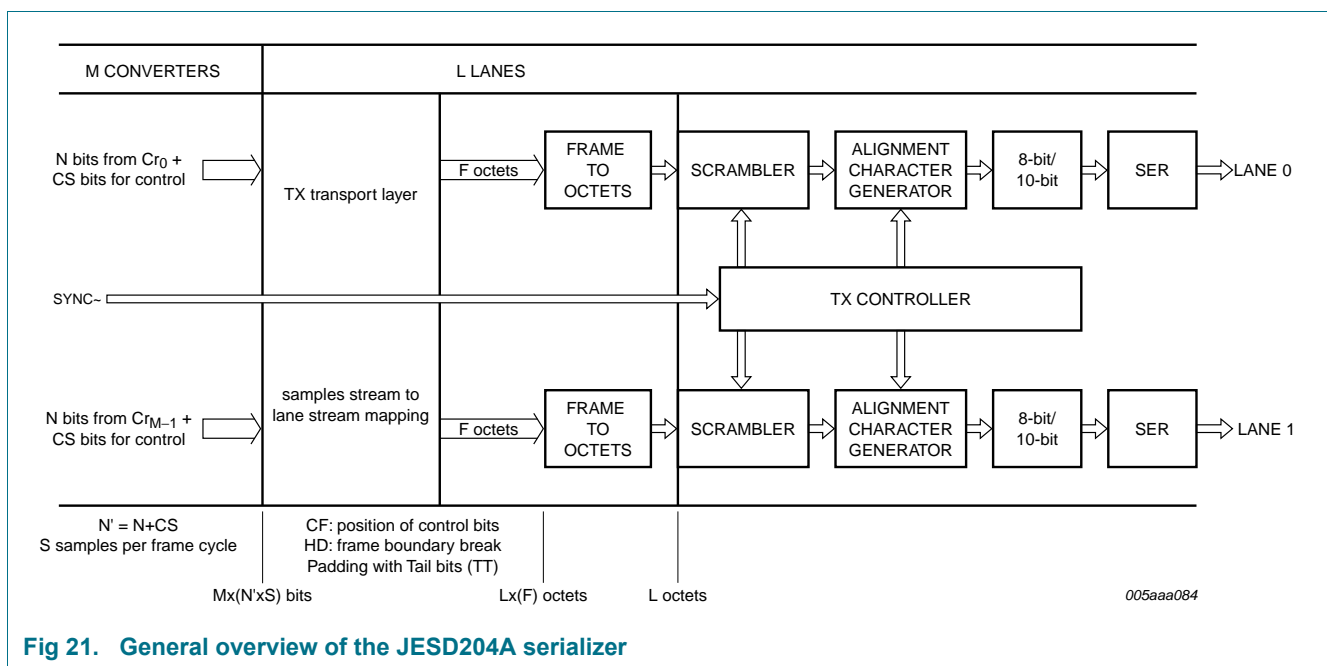
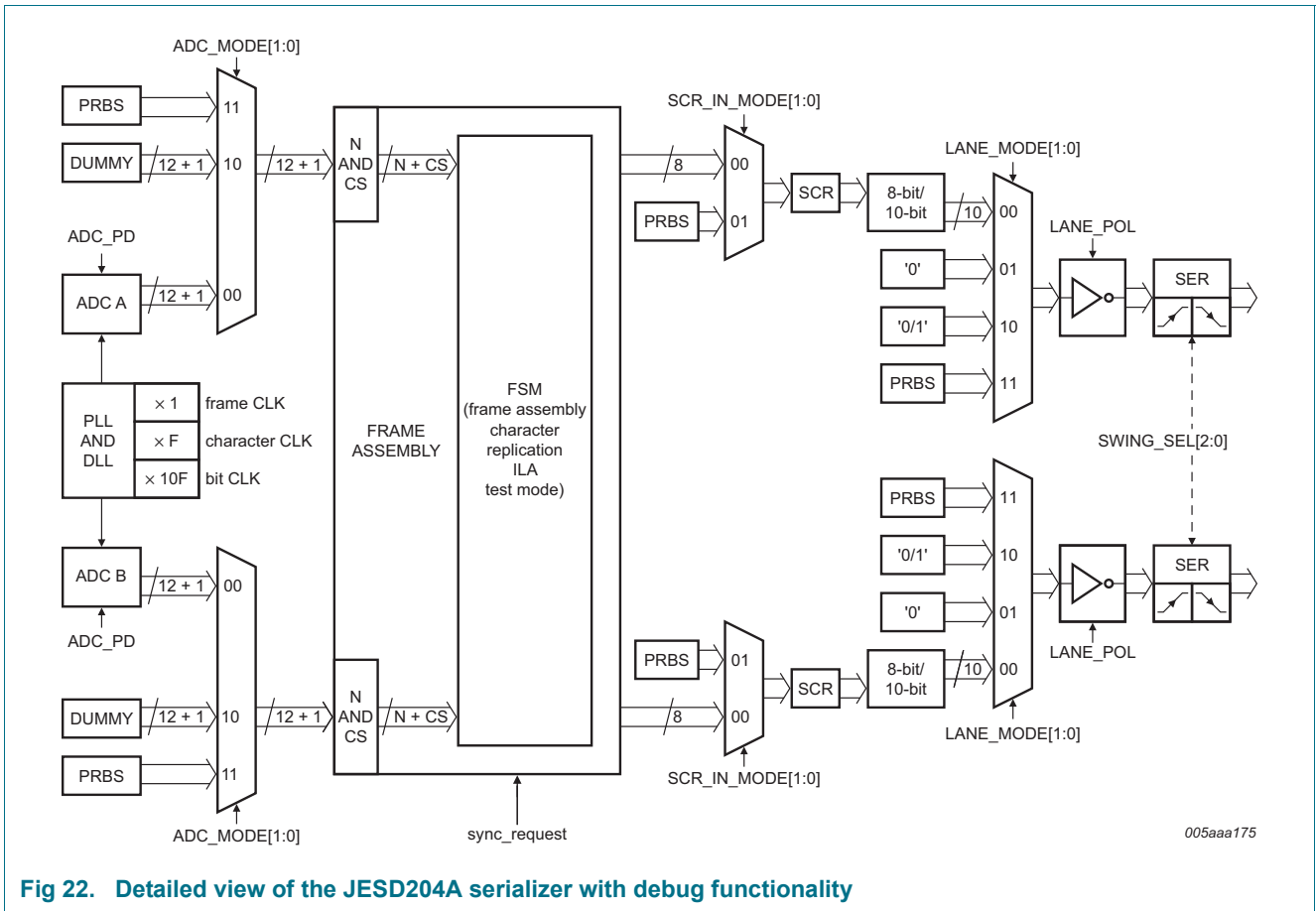

Fig 21. General overview of the JESD204A serializer



005aaa175

Fig 22. Detailed view of the JESD204A serializer with debug functionality

### 11.5.2 ADC core output codes versus input voltage

Table 13 shows the data output codes for a given analog input voltage.

Table 13. Output codes versus input voltage

INP – INM (V)	Offset binary	Two's complement	OTR
< -1	0000 0000 0000	1000 0000 0000	1
-1.0000000	0000 0000 0000	1000 0000 0000	0
-0.9995117	0000 0000 0001	1000 0000 0001	0
-0.9990234	0000 0000 0010	1000 0000 0010	0
-0.9985352	0000 0000 0011	1000 0000 0011	0
-0.9980469	0000 0000 0100	1000 0000 0100	0
....	....	....	0
-0.0009766	0111 1111 1110	1111 1111 1110	0
-0.0004883	0111 1111 1111	1111 1111 1111	0
0.0000000	1000 0000 0000	0000 0000 0000	0
+0.0004883	1000 0000 0001	0000 0000 0001	0
+0.0009766	1000 0000 0010	0000 0000 0010	0
....	....	....	0
+0.9980469	1111 1111 1011	0111 1111 1011	0

Table 13. Output codes versus input voltage ...continued

INP – INM (V)	Offset binary	Two's complement	OTR
+0.9985352	1111 1111 1100	0111 1111 1100	0
+0.9990234	1111 1111 1101	0111 1111 1101	0
+0.9995117	1111 1111 1110	0111 1111 1110	0
+1.0000000	1111 1111 1111	0111 1111 1111	0
> +1	1111 1111 1111	0111 1111 1111	1

## 11.6 Serial Peripheral Interface (SPI)

### 11.6.1 Register description

The ADC1213D serial interface is a synchronous serial communications port allowing for easy interfacing with many industry microprocessors. It provides access to the registers that control the operation of the chip in both read and write modes.

This interface is configured as a 3-wire type (SDIO as bidirectional pin).

SCLK acts as the serial clock, and  $\overline{\text{CS}}$  acts as the serial chip select.

Each read/write operation is sequenced by the  $\overline{\text{CS}}$  signal and enabled by a LOW level to drive the chip with 2 bytes to 5 bytes, depending on the content of the instruction byte (see Table 14).

Table 14. SPI instruction bytes

Bit	MSB							LSB
	7	6	5	4	3	2	1	0
Description	R/W <sup>[1]</sup>	W1	W0	A12	A11	A10	A9	A8
	A7	A6	A5	A4	A3	A2	A1	A0

[1] R/W indicates whether a read (logic 1) or write (logic 0) transfer occurs after the instruction byte

Table 15. Read or Write mode access description

R/W <sup>[1]</sup>	Description
0	Write mode operation
1	Read mode operation

[1] Bits W1 and W0 indicate the number of bytes transferred after the instruction byte.

Table 16. Number of bytes to be transferred

W1	W0	Number of bytes transferred
0	0	1 byte
0	1	2 bytes
1	0	3 bytes
1	1	4 or more bytes

Bits A12 to A0 indicate the address of the register being accessed. In the case of a multiple byte transfer, this address is the first register to be accessed. An address counter is incremented to access subsequent addresses.

The steps for a data transfer:

1. The falling edge on pin  $\overline{CS}$  in combination with a rising edge on pin SCLK determine the start of communications.
2. The first phase is the transfer of the 2-byte instruction.
3. The second phase is the transfer of the data which can vary in length but is always be a multiple of 8 bits. The MSB is always sent first (for instruction and data bytes)
4. A rising edge on pin  $\overline{CS}$  indicates the end of data transmission.

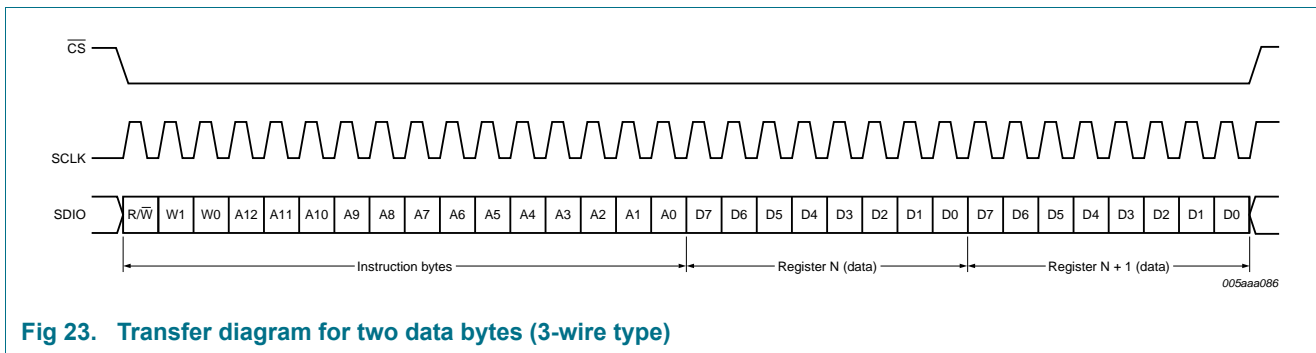

**Fig 23. Transfer diagram for two data bytes (3-wire type)**

### 11.6.2 Channel control

The two ADC channels can be configured at the same time or separately. By using the register “Channel index”, the user can choose which ADC channel receives the next SPI-instruction. By default the channel A and B receives the same instructions in write mode. In read mode only A is active.



**Table 17. Register allocation map**

Address (hex)	Register name	Access <sup>[1]</sup>	Bit definition										Default (bin)
			Bit 7	Bit 6	Bit 5	Bit 4	Bit 3	Bit 2	Bit 1	Bit 0			
<b>ADC control register</b>													
0003	Channel index	R/W	-	-	-	-	-	-	-	ADCB	ADCA	1111 1111	
0005	Reset and Power-down modes	R/W	SW_RST	-	-	-	-	-	-	PD[1:0]		0000 0000	
0006	Clock	R/W	-	-	-	SE_SEL	DIFF_SE	-	CLKDIV2_SEL	DCS_EN		0000 0001	
0008	Vref	R/W	-	-	-	-	INTREF_EN	-	INTREF[2:0]			0000 0000	
0013	Offset	R/W	-	-	-	-	DIG_OFFSET[5:0]					0000 0000	
0014	Test pattern 1	R/W	-	-	-	-	-	-	TESTPAT_1[2:0]			0000 0000	
0015	Test pattern 2	R/W	TESTPAT_2[11:4]										0000 0000
0016	Test pattern 3	R/W	TESTPAT_3[3:0]										0000 0000
<b>JESD204A control</b>													
0801	Ser_Status	R	RXSYNC_ERROR	RESERVED[2:0]		0	0	0	POR_TST	RESERVED		0010 0000	
0802	Ser_Reset	R/W	SW_RST	0	0	FSM_SW_RST	0	0	0	0	0	0000 0000	
0803	Ser_Cfg_Setup	R/W	0	0	0	0	0	CFG_SETUP[3:0]				0000 1000	
0805	Ser_Control1	R/W	0	TRISTATE_CFG_PINS	0	0	0	0	0	0	0	0100 1001	
0806	Ser_Control2	R/W	0	0	0	0	0	0	0	0	0	0000 0011	
0808	Ser_Analog_Ctrl	R/W	0	0	0	0	0	0	0	0	0	0000 0011	
0809	Ser_ScramblerA	R/W	0	0	0	0	0	0	0	0	0	0000 0000	
080A	Ser_ScramblerB	R/W	0	0	0	0	0	0	0	0	0	1111 1111	
080B	Ser_PRBS_Ctrl	R/W	0	0	0	0	0	0	0	0	0	0000 0000	
0820	Cfg_0_DID	R*	DID[7:0]										1110 1101
0821	Cfg_1_BID	R/W*	0	0	0	0	0	0	0	0	0	0000 1010	
0822	Cfg_3_SCR_L	R/W*	SCR	0	0	0	0	0	0	0	L	0000 0000	
0823	Cfg_4_F	R/W*	0	0	0	0	0	0	0	0	F[2:0]	0000 0001	

Table 17. Register allocation map ...continued

Address (hex)	Register name	Access <sup>[1]</sup>	Bit definition								Default (bin)	
			Bit 7	Bit 6	Bit 5	Bit 4	Bit 3	Bit 2	Bit 1	Bit 0		
0824	Cfg_5_K	R/W*	0	0	0				K[4:0]			0000 1000
0825	Cfg_6_M	R/W*	0	0	0	0	0	0			M	0000 0000
0826	Cfg_7_CS_N	R/W*	0	CS[0]	0	0				N[3:0]		0100 0010
0827	Cfg_8_Np	R/W	0	0	0				NP[4:0]			0000 1111
0828	Cfg_9_S	R/W*	0	0	0	0	0	0			S	0000 0000
0829	Cfg_10_HD_CF	R/W*	HD	0	0	0	0				CF[1:0]	0000 0000
082C	Cfg_01_2_LID	R/W*	0	0	0				LID[4:0]			0001 1011
082D	Cfg_02_2_LID	R/W*	0	0	0				LID[4:0]			0001 1100
084C	Cfg01_13_FCHK	R							FCHK[7:0]			0000 0000
084D	Cfg02_13_FCHK	R							FCHK[7:0]			0000 0000
0870	Lane0_0_Ctrl	R/W	0	SCR_IN_MODE	LANE_MODE[1:0]	0	LANE_POL	LANE_CLK_POS_EDGE			LANE_PD	0000 0001
0871	Lane1_0_Ctrl	R/W	0	SCR_IN_MODE	LANE_MODE[1:0]	0	LANE_POL	LANE_CLK_POS_EDGE			LANE_PD	0000 0000
0890	ADCA_0_Ctrl	R/W	0	0	ADC_MODE[1:0]	0	0	0			ADC_PD	0000 0001
0891	ADCB_0_Ctrl	R/W	0	0	ADC_MODE[1:0]	0	0	0			ADC_PD	0000 0000

[1] an "\*" in the Access column means that this register is subject to control access conditions in Write mode.

### 11.6.3 Register description

#### 11.6.3.1 ADC control register

**Table 18. Register Channel index (address 0003h)**

Default values are highlighted.

Bit	Symbol	Access	Value	Description
7 to 2	not used	-	111111	not used
1	ADCB	R/W		ADC B gets the next SPI command:
			0	ADC B not selected
			1	<b>ADC B selected</b>
0	ADCA	R/W		ADC A gets the next SPI command:
			0	ADC A not selected
			1	<b>ADC A selected</b>

**Table 19. Register Reset and Power-down mode (address 0005h)**

Default values are highlighted.

Bit	Symbol	Access	Value	Description
7	SW_RST	R/W		reset digital part:
			0	no reset
			1	performs a reset of the digital part
6 to 4	RESERVED[2:0]	-	<b>000</b>	<b>reserved</b>
3 to 2	-	-	00	not used
1 to 0	PD[1:0]	R/W		Power-down mode:
			<b>00</b>	<b>normal (power-up)</b>
			01	full power-down
			10	sleep
			11	normal (power-up)

**Table 20. Register Clock (address 0006h)**

Default values are highlighted.

Bit	Symbol	Access	Value	Description
7 to 5	-	-	000	not used
4	SE_SEL	R/W		select SE clock input pin:
			0	<b>select CLKM input</b>
			1	select CLKP input
3	DIFF_SE	R/W		differential/single-ended clock input select:
			0	<b>fully differential</b>
			1	single-ended
2	-	-	0	not used
1	CLKDIV2_SEL	R/W		select clock input divider by 2:
			0	<b>disable</b>
			1	active

**Table 20. Register Clock (address 0006h) ...continued**

Default values are highlighted.

Bit	Symbol	Access	Value	Description
0	DCS_EN	R/W		duty cycle stabilizer enable:
			0	disable
			1	active

**Table 21. Register Vref (address 0008h)**

Default values are highlighted.

Bit	Symbol	Access	Value	Description
7 to 4	-	-	0000	not used
3	INTREF_EN	R/W		enable internal programmable VREF mode:
			0	disable
			1	active
2 to 0	INTREF[2:0]	R/W		programmable internal reference:
			000	0 dB (FS=2 V)
			001	-1 dB (FS=1.78 V)
			010	-2 dB (FS=1.59 V)
			011	-3 dB (FS=1.42 V)
			100	-4 dB (FS=1.26 V)
			101	-5 dB (FS=1.12 V)
			110	-6 dB (FS=1 V)
			111	not used

**Table 22. Digital offset adjustment (address 0013h)**

Default values are highlighted.

Register offset:		
Decimal	DIG_OFFSET[5:0]	
+31	011111	+31 LSB
...	...	...
0	000000	0
...	...	...
-32	100000	-32 LSB

**Table 23. Register Test pattern 1 (address 0014h)**

Default values are highlighted.

Bit	Symbol	Access	Value	Description
7 to 3	-	-	00000	not used
2 to 0	TESTPAT_1[2:0]	R/W		digital test pattern:
			<b>000</b>	<b>off</b>
			001	mid-scale
			010	- FS
			011	+ FS
			100	toggle '1111..1111'/'0000..0000'
			101	custom test pattern, to be written in register 0015h and 0016h
			110	'010101...'
			111	'101010...'

**Table 24. Register Test pattern 2 (address 0015h)**

Default values are highlighted.

Bit	Symbol	Access	Value	Description
7 to 0	TESTPAT_2[11:4]	R/W	<b>00000000</b>	custom digital test pattern (bit 11 to 4)

**Table 25. Register Test pattern 3 (address 0016h)**

Default values are highlighted.

Bit	Symbol	Access	Value	Description
7 to 4	TESTPAT_3[3:0]	R/W	<b>0000</b>	custom digital test pattern (bit 3 to 0)
3 to 0	-	-	0000	not used

### 11.6.4 JESD204A digital control registers

**Table 26. Ser\_Status (address 0801h)**

Default values are highlighted.

Bit	Symbol	Access	Value	Description
7	RXSYNC_ERROR	R	0	set to 1 when a synchronization error occurs
6 to 4	RESERVED[2:0]	-	<b>010</b>	reserved
3 to 2	-	-	0	not used
1	POR_TST	R	<b>1</b>	power-on-reset
0	RESERVED	-	-	reserved

**Table 27. Ser\_Reset (address 0802h)**

Default values are highlighted.

Bit	Symbol	Access	Value	Description
7	SW_RST	R/W	<b>0</b>	initiates a software reset of the JESD204A unit
6 to 4	-	-	000	not used
3	FSM_SW_RST	R/W	<b>0</b>	initiates a software reset of the internal state machine of JESD204A unit
2 to 0	-	-	000	not used

**Table 28. Ser\_Cfg\_Setup (address 0803h)**

Default values are highlighted.

Bit	Symbol	Access	Value	Description
7 to 4	-	-	0000	not used
3 to 0	CFG_SETUP[3:0]	R/W		quick configuration of JESD204A. These settings overrule the CFG_PAD configuration (see Table 29).

**Table 29. JESD204A configuration table**

CFG_SETUP[3:0]	ADC A	ADC B	Lane 0	Lane 1	F <sup>[1]</sup>	HD <sup>[1]</sup>	K <sup>[1]</sup>	M <sup>[1]</sup>	L <sup>[1]</sup>	Comment	CS <sup>[1]</sup>	CF <sup>[1]</sup>	S <sup>[1]</sup>	
0	0000	<b>ON</b>	<b>ON</b>	<b>ON</b>	<b>ON</b>	2	0	9	2	2	(F × K) ≥ 17	1	0	1
1	0001	<b>ON</b>	<b>ON</b>	<b>ON</b>	OFF	4	0	5	2	1	(F × K) ≥ 17	1	0	1
2	0010	<b>ON</b>	<b>ON</b>	OFF	<b>ON</b>	4	0	5	2	1	(F × K) ≥ 17	1	0	1
3	0011	<b>ON</b>	OFF	<b>ON</b>	<b>ON</b>	1	1	17	1	2	(F × K) ≥ 17	1	0	1
4	0100	OFF	<b>ON</b>	<b>ON</b>	<b>ON</b>	1	1	17	1	2	(F × K) ≥ 17	1	0	1
5	0101	<b>ON</b>	OFF	<b>ON</b>	OFF	2	0	9	1	1	(F × K) ≥ 17	1	0	1
6	0110	<b>ON</b>	OFF	OFF	<b>ON</b>	2	0	9	1	1	(F × K) ≥ 17	1	0	1
7	0111	OFF	<b>ON</b>	<b>ON</b>	OFF	2	0	9	1	1	(F × K) ≥ 17	1	0	1
8	1000	OFF	<b>ON</b>	OFF	<b>ON</b>	2	0	9	1	1	(F × K) ≥ 17	1	0	1
9	1001										reserved			
10	1010										reserved			
11	1011										reserved			
12	1100										reserved			
13	1101										reserved			
14	1110	<b>ON</b>	<b>ON</b>	<b>ON</b>	<b>ON</b>	2	0	9	2	2	test: loop alignment	1	0	1
15	1111	OFF	OFF	OFF	OFF	2	0	9	2	2	chip power-down	1	0	1

[1] F: Octets per frame clock cycle

HD: High-density mode

K: Frame per multi-frame

M: Converters per device

L: Lane per converter device

CS: Number of control bits per conversion sample

CF: Control words per frame clock cycle and link

S: Number of samples transmitted per single converter per frame cycle

**Table 30. Ser\_Control1 (address 0805h)**

Default values are highlighted.

Bit	Symbol	Access	Value	Description
7	-	-	0	not used
6	TRISTATE_CFG_PINS	R/W	<b>1</b>	<b>pins CFG3 to CFG0 are set to high-impedance. Switch to 0 automatically after start-up or reset.</b>
5	SYNC_POL	R/W		defines the sync signal polarity:
			<b>0</b>	<b>synchronization signal is active LOW</b>
			1	synchronization signal is active HIGH
4	SYNC_SINGLE_ENDED	R/W		defines the input mode of the sync signal:
			<b>0</b>	<b>synchronization input mode is set in Differential mode</b>
			1	synchronization input mode is set in Single-ended mode
3	-	-	1	not used
2	REV_SCR	-		LSBs are swapped with MSBs at the scrambler input:
			<b>0</b>	disable
			1	enable
1	REV_ENCODER	-		LSBs are swapped with MSBs at the 8-bit/10-bit encoder input:
			<b>0</b>	disable
			1	enable
0	REV_SERIAL	-		LSBs are swapped with MSBs at the lane input:
			0	disable
			<b>1</b>	<b>enable</b>

**Table 31. Ser\_Control2 (address 0806h)**

Default values are highlighted.

Bit	Symbol	Access	Value	Description
7 to 2	-	-	000000	not used
1	SWAP_LANE_1_2	R/W		swaps the outputs of the JESD204A unit (output buffer A is connected to Lane 1, output buffer B is connected to Lane 0):
			<b>0</b>	disable
			1	enable
0	SWAP_ADC_0_1	R/W		swaps the inputs of the JESD204A unit (ADC A output is connected to ADC input B, ADC B is connected to ADC input A):
			<b>0</b>	disable
			1	enable

**Table 32. Ser\_Analog\_Ctrl (address 0808h)**

Default values are highlighted.

Bit	Symbol	Access	Value	Description
7 to 3	-	-	00000	not used
2 to 0	SWING_SEL[2:0]	R/W	<b>011</b>	<b>defines the swing output for the lane pads</b>

**Table 33. Ser\_ScramblerA (address 0809h)**

Default values are highlighted.

Bit	Symbol	Access	Value	Description
7	-	-	0	not used
6 to 0	LSB_INIT[6:0]	R/W	0000000	defines the initialization vector for the scrambler polynomial (lower)

**Table 34. Ser\_ScramblerB (address 080Ah)**

Default values are highlighted.

Bit	Symbol	Access	Value	Description
7 to 0	MSB_INIT[7:0]	R/W	11111111	defines the initialization vector for the scrambler polynomial (upper)

**Table 35. Ser\_PRBS\_Ctrl (address 080Bh)**

Default values are highlighted.

Bit	Symbol	Access	Value	Description
7 to 2	-	-	000000	not used
1 to 0	PRBS_TYPE[1:0]	R/W		defines the type of Pseudo-Random Binary Sequence (PRBS) generator to be used:
			00 (reset)	PRBS-7
			01	PRBS-7
			10	PRBS-23
			11	PRBS-31

**Table 36. Cfg\_0\_DID (address 0820h)**

Default values are highlighted.

Bit	Symbol	Access	Value	Description
7 to 0	DID[7:0]	R	11101101	defines the device (= link) identification number

**Table 37. Cfg\_1\_BID (address 0821h)**

Default values are highlighted.

Bit	Symbol	Access	Value	Description
7 to 4	-	-	0000	not used
3 to 0	BID[3:0]	R/W	1010	defines the bank ID – extension to DID

**Table 38. Cfg\_3\_SCR\_L (address 0822h)**

Default values are highlighted.

Bit	Symbol	Access	Value	Description
7	SCR	R/W	0	scrambling enabled
6 to 1	-	-	000000	not used
0	L	R/W	0	defines the number of lanes per converter device, minus 1

**Table 39. Cfg\_4\_F (address 0823h)**

Default values are highlighted.

Bit	Symbol	Access	Value	Description
7 to 3	-	-	00000	not used
2 to 0	F[2:0]	R/W	001	defines the number of octets per frame, minus 1



**Table 40. Cfg\_5\_K (address 0824h)**

Default values are highlighted.

Bit	Symbol	Access	Value	Description
7 to 5	-	-	000	not used
4 to 0	K[4:0]	R/W	01000	defines the number of frames per multiframe, minus 1

**Table 41. Cfg\_6\_M (address 0825h)**

Default values are highlighted.

Bit	Symbol	Access	Value	Description
7 to 1	-	-	0000000	not used
0	M	R/W	0	defines the number of converters per device, minus 1

**Table 42. Cfg\_7\_CS\_N (address 0826h)**

Default values are highlighted.

Bit	Symbol	Access	Value	Description
7	-	-	0	not used
6	CS[0]	R/W	1	defines the number of control bits per sample, minus 1
5 to 4	-	-	00	not used
3 to 0	N[3:0]	R/W	0010	defines the converter resolution

**Table 43. Cfg\_8\_Np (address 0827h)**

Default values are highlighted.

Bit	Symbol	Access	Value	Description
7 to 5	-	-	000	not used
4 to 0	NP[4:0]	R/W	01111	defines the total number of bits per sample, minus 1

**Table 44. Cfg\_9\_S (address 0828h)**

Default values are highlighted.

Bit	Symbol	Access	Value	Description
7 to 1	-	-	0000000	not used
0	S	R/W	0	defines number of samples per converter per frame cycle

**Table 45. Cfg\_10\_HD\_CF (address 0829h)**

Default values are highlighted.

Bit	Symbol	Access	Value	Description
7	HD	R/W	0	defines high density format
6 to 2	-	-	00000	not used
1 to 0	CF[1:0]	R/W	00	defines number of control words per frame clock cycle per link

**Table 46. Cfg\_01\_2\_LID (address 082Ch)**

Default values are highlighted.

Bit	Symbol	Access	Value	Description
7 to 5	-	-	000	not used
4 to 0	LID[4:0]	R/W	<b>11011</b>	<b>defines lane 0 identification number</b>

**Table 47. Cfg\_02\_2\_LID (address 082Dh)**

Default values are highlighted.

Bit	Symbol	Access	Value	Description
7 to 5	-	-	000	not used
4 to 0	LID[4:0]	R/W	<b>11100</b>	<b>defines lane 1 identification number</b>

**Table 48. Cfg01\_13\_FCHK (address 084Ch)**

Default values are highlighted.

Bit	Symbol	Access	Value	Description
7 to 0	FCHK[7:0]	R	00000000	defines the checksum value for lane 0 checksum corresponds to the sum of all the link configuration parameters modulo 256 (as defined in JEDEC Standard No.204A)

**Table 49. Cfg02\_13\_FCHK (address 084Dh)**

Default values are highlighted.

Bit	Symbol	Access	Value	Description
7 to 0	FCHK[7:0]	R	00000000	defines the checksum value for lane 1 checksum corresponds to the sum of all the link configuration parameters modulo 256 (as defined in JEDEC Standard No.204A)

**Table 50. Lane0\_0\_Ctrl (address 0870h)**

Default values are highlighted.

Bit	Symbol	Access	Value	Description
7	-	-	0	not used
6	SCR_IN_MODE	R/W	<b>0</b> (reset)	defines the input type for scrambler and 8-bit/10-bit units: <b>(normal mode) = input of the scrambler and 8-bit/10-bit units is the output of the frame assembly unit.</b>
			1	input of the scrambler and 8-bit/10-bit units is the PRBS generator (PRBS type is defined with "PRBS_TYPE" (Ser_PRBS_Ctrl register))
5 to 4	LANE_MODE[1:0]	R/W	<b>00</b> (reset)	defines output type of lane output unit: <b>normal mode: lane output is the 8-bit/10-bit output unit</b>
			01	constant mode: lane output is set to a constant (0 × 0)
			10	toggle mode: lane output is toggling between 0 × 0 and 0 × 1
			11	PRBS mode: lane output is the PRBS generator (PRBS type is defined with "PRBS_TYPE" (Ser_PRBS_Ctrl register))
3	-	-	0	not used
2	LANE_POL	R/W	<b>0</b>	defines lane polarity: <b>lane polarity is normal</b>
			1	lane polarity is inverted
1	LANE_CLK_POS_EDGE	R/W	<b>0</b>	defines lane clock polarity: <b>lane clock provided to the serializer is active on positive edge</b>
			1	lane clock provided to the serializer is active on negative edge

**Table 50. Lane0\_0\_Ctrl (address 0870h) ...continued**

Default values are highlighted.

Bit	Symbol	Access	Value	Description
0	LANE_PD	R/W		lane power-down control:
			0	lane is operational
			1	<b>lane is in Power-down mode</b>

**Table 51. Lane1\_0\_Ctrl (address 0871h)**

Default values are highlighted.

Bit	Symbol	Access	Value	Description
7	-	-	0	not used
6	SCR_IN_MODE	R/W		defines the input type for scrambler and 8-bit/10-bit units:
			0 (reset)	<b>(normal mode) = input of the scrambler and 8-bit/10-bit units is the output of the frame assembly unit.</b>
			1	input of the scrambler and 8-bit/10-bit units is the PRBS generator (PRBS type is defined with "PRBS_TYPE" (Ser_PRBS_Ctrl register)
5 to 4	LANE_MODE[1:0]	R/W		defines output type of lane output unit:
			00 (reset)	<b>normal mode: lane output is the 8-bit/10-bit output unit</b>
			01	constant mode: lane output is set to a constant (0x0)
			10	toggle mode: lane output is toggling between 0x0 and 0x1
			11	PRBS mode: lane output is the PRBS generator (PRBS type is defined with "PRBS_TYPE" (Ser_PRBS_Ctrl register)
3	-	-	0	not used
2	LANE_POL	R/W		defines lane polarity:
			0	<b>lane polarity is normal</b>
			1	lane polarity is inverted
1	LANE_CLK_POS_EDGE	R/W		defines lane clock polarity:
			0	<b>lane clock provided to the serializer is active on positive edge</b>
			1	lane clock provided to the serializer is active on negative edge
0	LANE_PD	R/W		lane power-down control:
			0	<b>lane is operational</b>
			1	lane is in Power-down mode

**Table 52. ADCA\_0\_Ctrl (address 0890h)**

Default values are highlighted.

Bit	Symbol	Access	Value	Description
7 to 6	-		00	not used
5 to 4	ADC_MODE[1:0]	R/W		defines input type of JESD204A unit:
			00 (reset)	<b>ADC output is connected to the JESD204A input</b>
			01	not used
			10	JESD204A input is fed with a dummy constant, set to: OTR = 0 and ADC[11:0] = "100110111010"
			11	JESD204A is fed with a PRBS generator (PRBS type is defined with "PRBS_TYPE" (Ser_PRBS_Ctrl register)

**Table 52. ADCA\_0\_Ctrl (address 0890h) ...continued**

Default values are highlighted.

Bit	Symbol	Access	Value	Description
3 to 1	-		000	not used
0	ADC_PD	R/W		ADC power-down control:
			0	ADC is operational
			1	<b>ADC is in Power-down mode</b>

**Table 53. ADCB\_0\_ctrl (address 0891h)**

Default values are highlighted.

Bit	Symbol	Access	Value	Description
7 to 6	-	-	00	not used
5 to 4	ADC_MODE[1:0]	R/W		defines input type of JESD204A unit
			00 (reset)	<b>ADC output is connected to the JESD204A input</b>
			01	not used
			10	JESD204A input is fed with a dummy constant, set to: OTR = 0 and ADC[11:0] = "100110111010"
			11	JESD204A is fed with a PRBS generator (PRBS type is defined with "PRBS_TYPE" (Ser_PRBS_ctrl register)
3 to 1	-	-	000	not used
0	ADC_PD	R/W		ADC power-down control:
			0	<b>ADC is operational</b>
			1	ADC is in Power-down mode

12. Package outline

HVQFN56: plastic thermal enhanced very thin quad flat package; no leads; 56 terminals; body 8 x 8 x 0.85 mm

SOT684-7

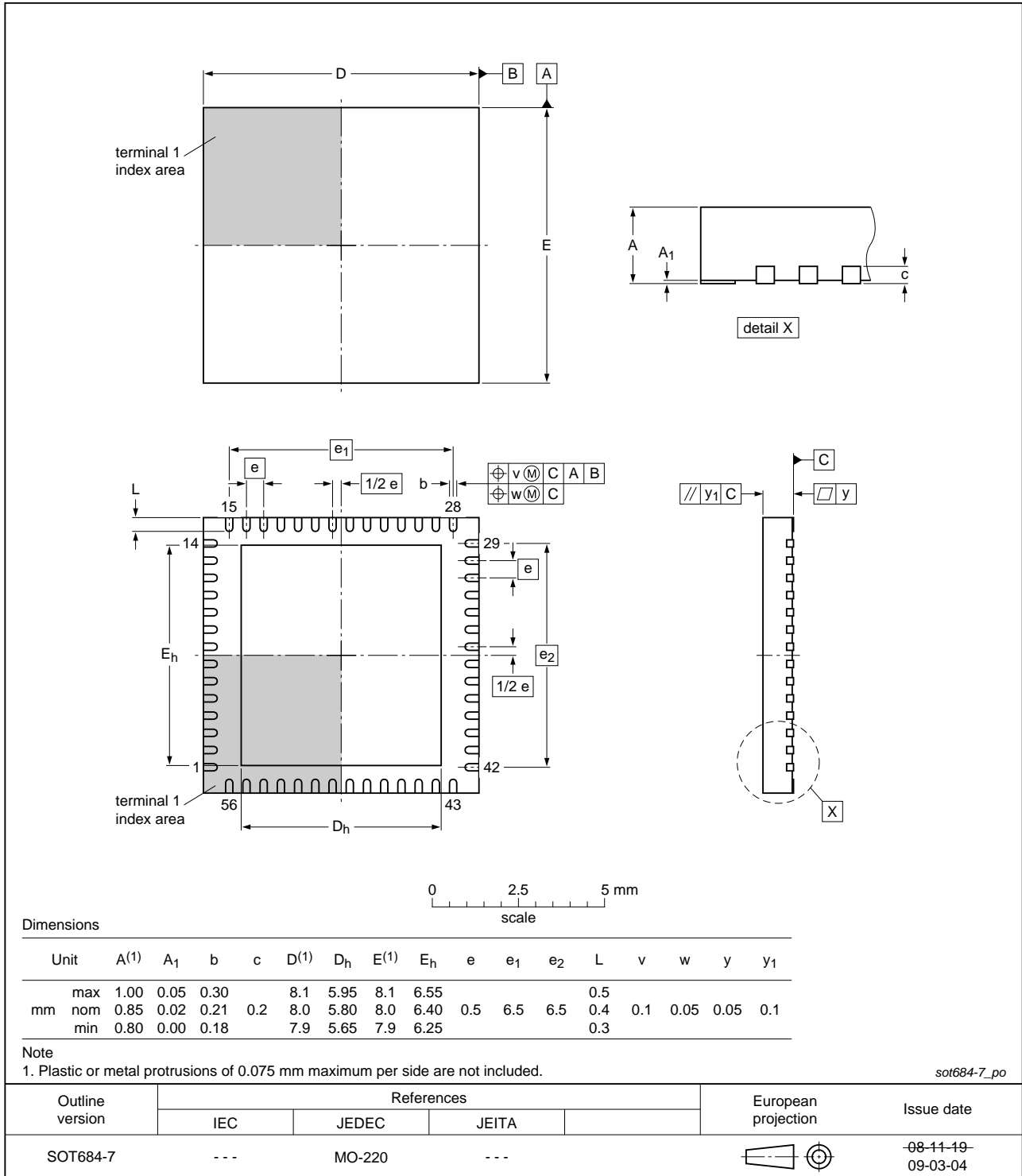

Fig 24. Package outline SOT684-7 (HVQFN56)

## 13. Abbreviations

**Table 54. Abbreviations**

<b>Acronym</b>	<b>Description</b>
ADC	Analog-to-Digital Converter
DCS	Duty Cycle Stabilizer
ESD	ElectroStatic Discharge
IF	Intermediate Frequency
IMD	InterModulation Distortion
LSB	Least Significant Bit
LVCMOS	Low Voltage Complementary Metal Oxide Semiconductor
LVPECL	Low-Voltage Positive Emitter-Coupled Logic
MSB	Most Significant Bit
OTR	Out-of-Range
PRBS	Pseudo-Random Binary Sequence
SFDR	Spurious-Free Dynamic Range
SNR	Signal-to-Noise Ratio
SPI	Serial Peripheral Interface
TX	Transmitter

## 14. Revision history

**Table 55. Revision history**

Document ID	Release date	Data sheet status	Change notice	Supersedes
ADC1213D_SER v.8	20120702	Product data sheet	-	ADC1213D_SER v.7
ADC1213D_SER v.7	20110609	Product data sheet	-	ADC1213D_SER v.6
Modifications:	<ul style="list-style-type: none"> <li>Section 10.2 “Clock and digital output timing” has been updated.</li> </ul>			
ADC1213D_SER v.6	20110209	Product data sheet	-	ADC1213D_SER v.5
ADC1213D_SER v.5	20100423	Preliminary data sheet	-	ADC1213D_SER v.4
ADC1213D_SER v.4	20100412	Objective data sheet	-	ADC1213D065_080_105_125 v.3
ADC1213D065_080_105_125 v.3	20090617	Objective data sheet	-	ADC1213D065_080_105_125 v.2
ADC1213D065_080_105_125 v.2	20090604	Objective data sheet	-	ADC1213D065_080_105_125 v.1
ADC1213D065_080_105_125 v.1	20090528	Objective data sheet	-	-

## 15. Contact information

For more information or sales office addresses, please visit: <http://www.idt.com>

## 16. Contents

<b>1</b>	<b>General description</b> . . . . .	<b>1</b>	11.2.2	Programmable full-scale	17
<b>2</b>	<b>Features and benefits</b> . . . . .	<b>1</b>	11.2.3	Common-mode output voltage ( $V_{O(cm)}$ )	17
<b>3</b>	<b>Applications</b> . . . . .	<b>2</b>	11.2.4	Biasing	18
<b>4</b>	<b>Ordering information</b> . . . . .	<b>2</b>	11.3	Clock input	18
<b>5</b>	<b>Block diagram</b> . . . . .	<b>3</b>	11.3.1	Drive modes	18
<b>6</b>	<b>Pinning information</b> . . . . .	<b>4</b>	11.3.2	Equivalent input circuit	19
6.1	Pinning	4	11.3.3	Clock input divider	20
6.2	Pin description	4	11.3.4	Duty cycle stabilizer	20
<b>7</b>	<b>Limiting values</b> . . . . .	<b>6</b>	11.4	Digital outputs	20
<b>8</b>	<b>Thermal characteristics</b> . . . . .	<b>6</b>	11.4.1	Serial output equivalent circuit	20
<b>9</b>	<b>Static characteristics</b> . . . . .	<b>6</b>	11.5	JESD204A serializer	21
<b>10</b>	<b>Dynamic characteristics</b> . . . . .	<b>10</b>	11.5.1	Digital JESD204A formatter	21
10.1	Dynamic characteristics	10	11.5.2	ADC core output codes versus input voltage	22
10.2	Clock and digital output timing	11	11.6	Serial Peripheral Interface (SPI)	23
10.3	Serial output timing	12	11.6.1	Register description	23
10.4	SPI timing	13	11.6.2	Channel control	24
<b>11</b>	<b>Application information</b> . . . . .	<b>13</b>	11.6.3	Register description	27
11.1	Analog inputs	13	11.6.3.1	ADC control register	27
11.1.1	Input stage description	13	11.6.4	JESD204A digital control registers	29
11.1.2	Anti-kickback circuitry	14	<b>12</b>	<b>Package outline</b>	<b>37</b>
11.1.3	Transformer	15	<b>13</b>	<b>Abbreviations</b>	<b>38</b>
11.2	System reference and power management	16	<b>14</b>	<b>Revision history</b>	<b>39</b>
11.2.1	Internal/external reference	16	<b>15</b>	<b>Contact information</b>	<b>39</b>
			<b>16</b>	<b>Contents</b>	<b>40</b>