

PI3EQX6801ZDE
PI3EQX6801 SATA ReDriver

Table of Contents

General Introduction	2
How to Use Control Pins for Various Application	3
External Component Requirement.....	4
Layout Design Guide	5
Power-Supply Bypass.....	6
Power Supply Sequencing.....	6
Equalization Setting	6
Output Swing Setting	8
Pre-emphasis Setting.....	9
Typical Application Circuit.....	10
PCB Layout Sample.....	12

General Introduction

PI3EQX6801 SATA ReDriver™ device is developed to re-drive one full lane of SAS/SATA up to 6Gbps signal. The device has built-in continuous step output swing/pre-emphasis adjustment features, and delivers solid performance.

Packaging: 20-contact TQFN (4x4mm)

Main Application:

- ✓ Server
- ✓ Desktop
- ✓ Storage/Workstation

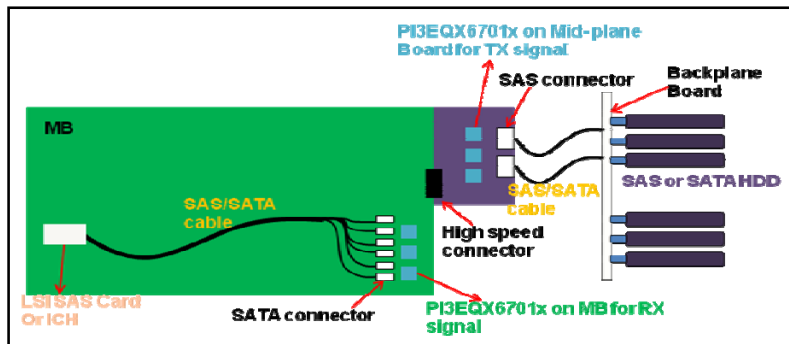

Figure 1a: Example of Typical Application

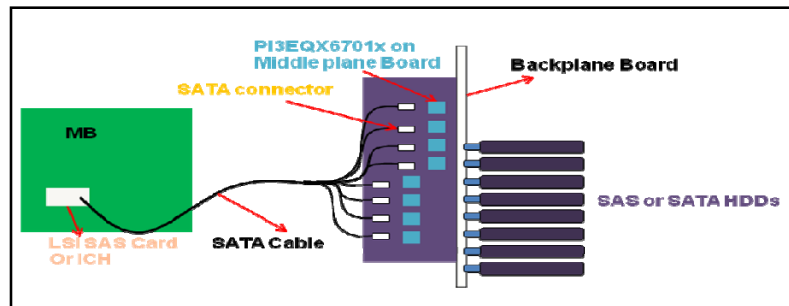

Figure 1b: Example of Typical Application

How to Use Control Pins for Various Application

PI3EQX6801 device comes with control pins: EN, OOB, TDet_EN# AB/BB, and A_EQ/B_EQ. Table1 is the setting selection for various applications.

Pins	Function Description	Setting Selection												
A_EN# B_EN#	Channel Enable Function w/ internal 200k pull-down resistor	High: Power-down mode Low: Normal Operation (default)												
DNC	Do NOT connect Only for 3.3V application	For 3.3V application, it must be not connected. For 1.5V application, it must be connected to 1.5V.												
A_EM B_EM	Output Emphasis Adjustment	They allow analog resistive adjustment by the resistor to connect to GND. (Note, recommend to use under 4.0dB Pre-emphasis)												
A_OS B_OS	Output Swing Adjustment	They allow analog resistive adjustment by the resistor to connect to GND. (Note, recommend to use 600mV for SATA application, 1000mV for SAS application)												
A_EQ B_EQ	Input Equalizer Adjustment Tri-level control	<table border="1"> <thead> <tr> <th>A_EQ/B_EQ</th> <th>3GHz</th> <th>Various Applications</th> </tr> </thead> <tbody> <tr> <td>0</td> <td>8 dB</td> <td>for 12~24 inch input trace</td> </tr> <tr> <td>V_{DD}/2</td> <td>4 dB (Default)</td> <td>for less than 12inch input trace</td> </tr> <tr> <td>1</td> <td>16 dB</td> <td>for 18~30 inch input trace</td> </tr> </tbody> </table>	A_EQ/B_EQ	3GHz	Various Applications	0	8 dB	for 12~24 inch input trace	V _{DD} /2	4 dB (Default)	for less than 12inch input trace	1	16 dB	for 18~30 inch input trace
A_EQ/B_EQ	3GHz	Various Applications												
0	8 dB	for 12~24 inch input trace												
V _{DD} /2	4 dB (Default)	for less than 12inch input trace												
1	16 dB	for 18~30 inch input trace												

Table 1: Setting Selection for Various Applications

PI3EQX6801 can work with 1.5V or 3.3V power supply. Table 2 below lists the power consumption for reference.

Power Supply	Power consumption (typical, mW)			
	Active (at 600mV Swing, 0db pre-emphasis)	Slumber mode	HDD unplug	Standby (Max.)
1.5V Power	162	22.5	1.5	0.089
3.3V Power	356	50	3.3	1.82

Table 2: Power Consumption

Note: PI3EQX6801 has the same pin-out and pin assignment as PI3EQX6701x.

1. If the customer currently uses PI3EQX6701x under +3.3V power application and intends to upgrade to PI3EQX6801, some changes MUST be taken care.
 - ✓ Resistor values on x_EM and x_OS pins should be changed based on the 3rd page of PI3EQX6801 datasheet.
 - ✓ The control on x_EQ pins of PI3EQX6801 is tri-level selection, Low/Open/High.

		PI3EQX6701C	PI3EQX6701D	PI3EQX6701E	PI3EQX6801	
A_EQ	Low	1dB	7dB	1dB	A_EQ/B_EQ	3 GHz
	High	4dB	11dB	4dB	0 (Low)	8 dB
B_EQ	Low	1dB	7dB	7dB	V _{DD} /2 (Open)	4 dB (Default)
	High	4dB	11dB	11dB	1 (High)	16 dB

2. If the customer currently uses PI3EQX6701x under +1.2V power application, PI3EQX6801 is not recommended because +1.5V power is required.

External Component Requirement

PI3EQX6801ZDE requires AC coupling capacitors for all redriver outputs. High-quality, low-ESR, X7R, 10nF, 0402-sized capacitors are recommended

Layout Design Guide

Layout Considerations for Differential Pairs

- The trace length miss-matching shall be less than 5 mils for the “+” and “-” traces in the same pairs
- Use wider trace width, with 100ohm differential impedance, to minimize the loss for long routes
- Target differential Zo of 100ohm ±20%
- More pair-to-pair spacing for minimal crosstalk coupling, it is recommended to have >3X gap spacing between differential pairs.
- It is preferable to route differential lines exclusively on one layer of the board, particularly for the input traces
- The use of vias should be avoided if possible, if vias must be used, they should be used sparingly and must be placed symmetrically for each side of a given differential pair.
- Route the differential signals away from other signals and noise sources on the printed circuit board

PCB Layout Trace Routings

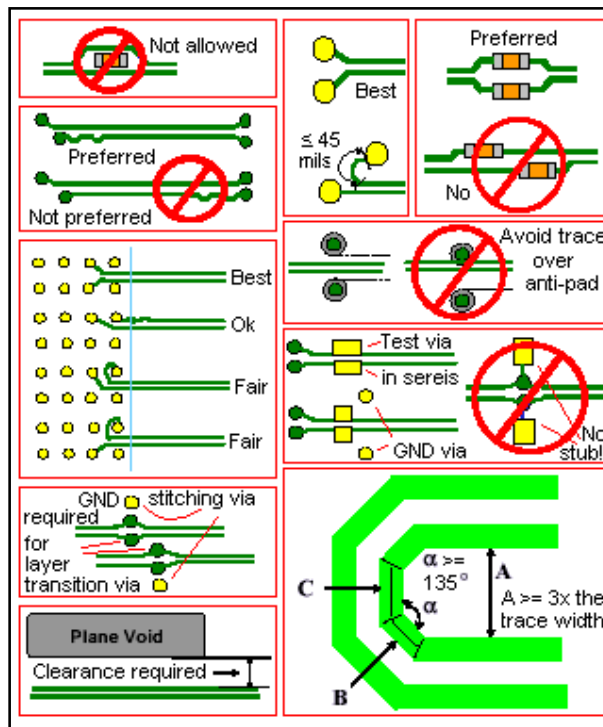

Figure 2: Layout Sample for Trace Routings

Power-Supply Bypass

Designers are advised to pay careful attention the details associated with high-speed design as well as providing a clean power supply; there are some approaches as recommendation.

- ✓ The supply (VDD) and ground (GND) pins should be connected to power planes routed on adjacent layers of the printed circuit board. The distance to plane should be <50mil.
- ✓ The layer thickness of the dielectric should be minimized so that the VDD and GND planes create a low inductance supply with distributed capacitance.
- ✓ Careful attention to supply bypassing through the proper use of bypass capacitors is required. A low-ESR 0.01uF bypass capacitor should be connected to each VDD pin such that the capacitor is placed as close as possible to PI3EQX6801ZDE. Smaller body size capacitors can help facilitate proper component placement. The distance of capacitors to IC body should be <100mil.
- ✓ One capacitor with capacitance in the range of 1uF to 10uF should be incorporated in the power supply bypassing design as well. It is can be either tantalum or an ultra-low ESR ceramic.

Power Supply Sequencing

Proper power supply sequencing is recommended for all devices. Always apply GND and VDD before applying signals, especially if the signal is not current limited.

Caution: Do NOT exceed the absolute maximum ratings because stresses beyond the listed ratings can cause permanent damage to the device.

Equalization Setting

Various Input Trace and Eye Test with different EQ setting

Figure 3 shows PI2EQX6811 test setup for different EQ setting, R in the figure represents PI2EQX6811.

Signal Source: PRBS2^7-1 pattern, Differential Voltage is 500mV, Pre-emphasis is 0dB

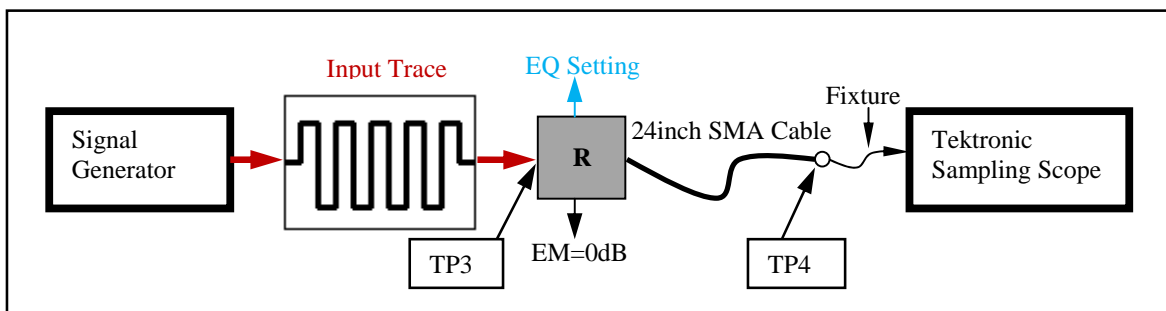

Figure 3: EQ Setting Test Setup for PI2EQX6811

	Input Trace Length	SEL[2..0] Setting	Input Eye at TP3	Output Eye at TP4
Eye Diagram vs. EQ setting at 6Gb/s	6 inch FR4 Lab trace (-2dB loss at 3GHz)	4dB (A_EQ or B_EQ =Open)		
	18 inch FR4 Lab trace (-6dB loss at 3GHz)	8dB (A_EQ or B_EQ =Low)		
	30 inch FR4 Lab trace (-10dB loss at 3GHz)	16dB (A_EQ or B_EQ =High)		
	48 inch FR4 Lab trace (-16dB loss at 3GHz)	16dB (A_EQ or B_EQ =High)		

Table 3: Eye Diagram at TP4 vs. Input FR4 trace and EQ setting at 6Gb/s for PI2EQ6811



	Input Trace Length	SEL[2..0] Setting	Input Eye at TP3	Output Eye at TP4
Eye Diagram vs. EQ setting at 3Gb/s	6 inch FR4 Lab trace (-1.2dB loss at 1.5GHz)	4dB (A_EQ or B_EQ =Open)		
	18 inch FR4 Lab trace (-3dB loss at 1.5GHz)	8dB (A_EQ or B_EQ =Low)		
	30 inch FR4 Lab trace (-5dB loss at 1.5GHz)	16dB (A_EQ or B_EQ =High)		
	48 inch FR4 Lab trace (-9dB loss at 1.5GHz)	16dB (A_EQ or B_EQ =High)		

Table 4: Eye Diagram at TP4 vs. Input FR4 trace and EQ setting at 6Gb/s for PI2EQ6811

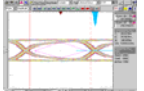
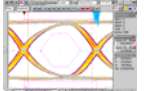
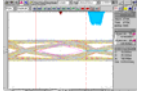
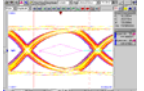
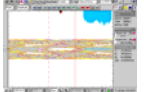
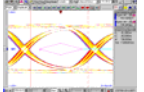
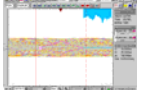
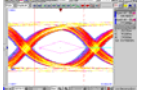
Output Swing Setting

Figure 4 shows PI3EQX6801ZDE test setup for different output swing setting, R in the figure represents PI3EQX6801ZDE.

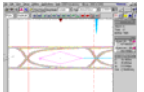
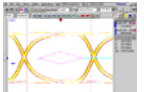
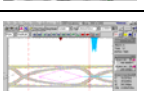
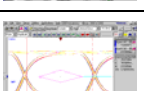
Signal Source: PRBS2^7-1 pattern, Differential Voltage is 500mV, Pre-emphasis is 0dB

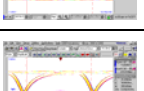
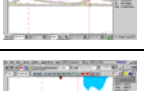
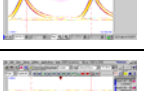
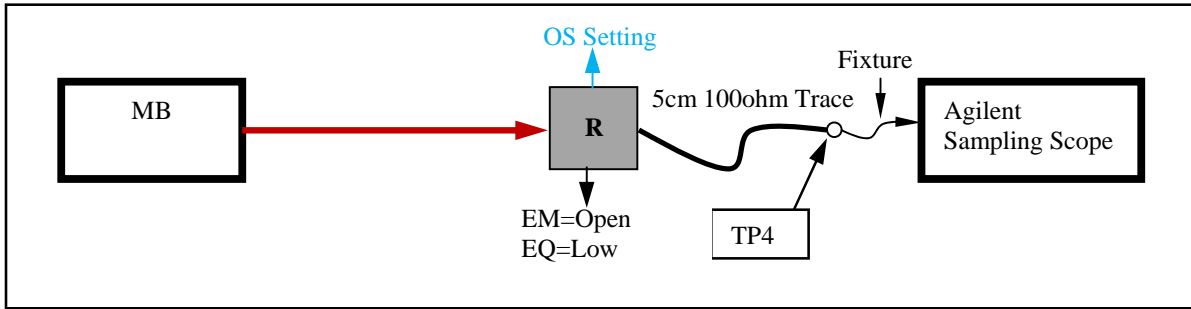

Figure 4: Output Swing Setting Test Setup for PI3EQX6801ZDE

	OS[1..0]=00	OS[1..0]=01	OS[1..0]=10	OS[1..0]=11
Output Swing at TP4 vs. OS setting at 3Gb/s				
Output Swing at TP4 vs. OS setting at 6Gb/s				

Table 5: Output Swing at TP4 vs. OS setting at 3Gb/s and 6Gb/s for PI3EQX6801ZDE

Pre-emphasis Setting

Figure 5 shows PI3EQX6801ZDE test setup for different Pre-emphasis setting, R in the figure represents PI3EQX6801ZDE.

Signal Source: PRBS2^7-1 pattern, Differential Voltage is 500mV, EQ setting is 0dB

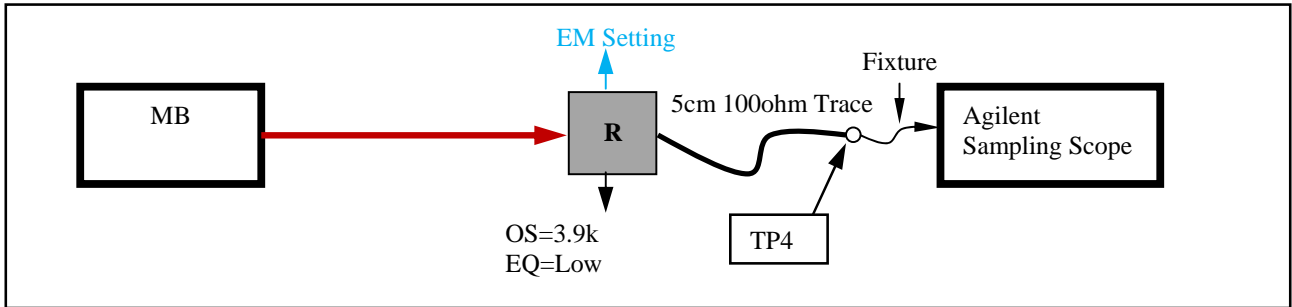

Figure 5: Pre-emphasis Setting Test Setup for PI3EQX6801ZDE

	A/B_EM=15kohm	A/B_EM =10kohm	A/B_EM =5.6kohm
Output Pre-emphasis at TP4 vs. EM setting at 3Gb/s			
Output Pre-emphasis at TP4 vs. EM setting at 6Gb/s			

Table 6: Pre-emphasis at TP4 vs. EM setting at 3Gb/s and 6Gb/s for PI3EQX6801ZDE

Typical Application Circuit

Figure 6 shows typical application circuit of PI3EQX6801ZDE.

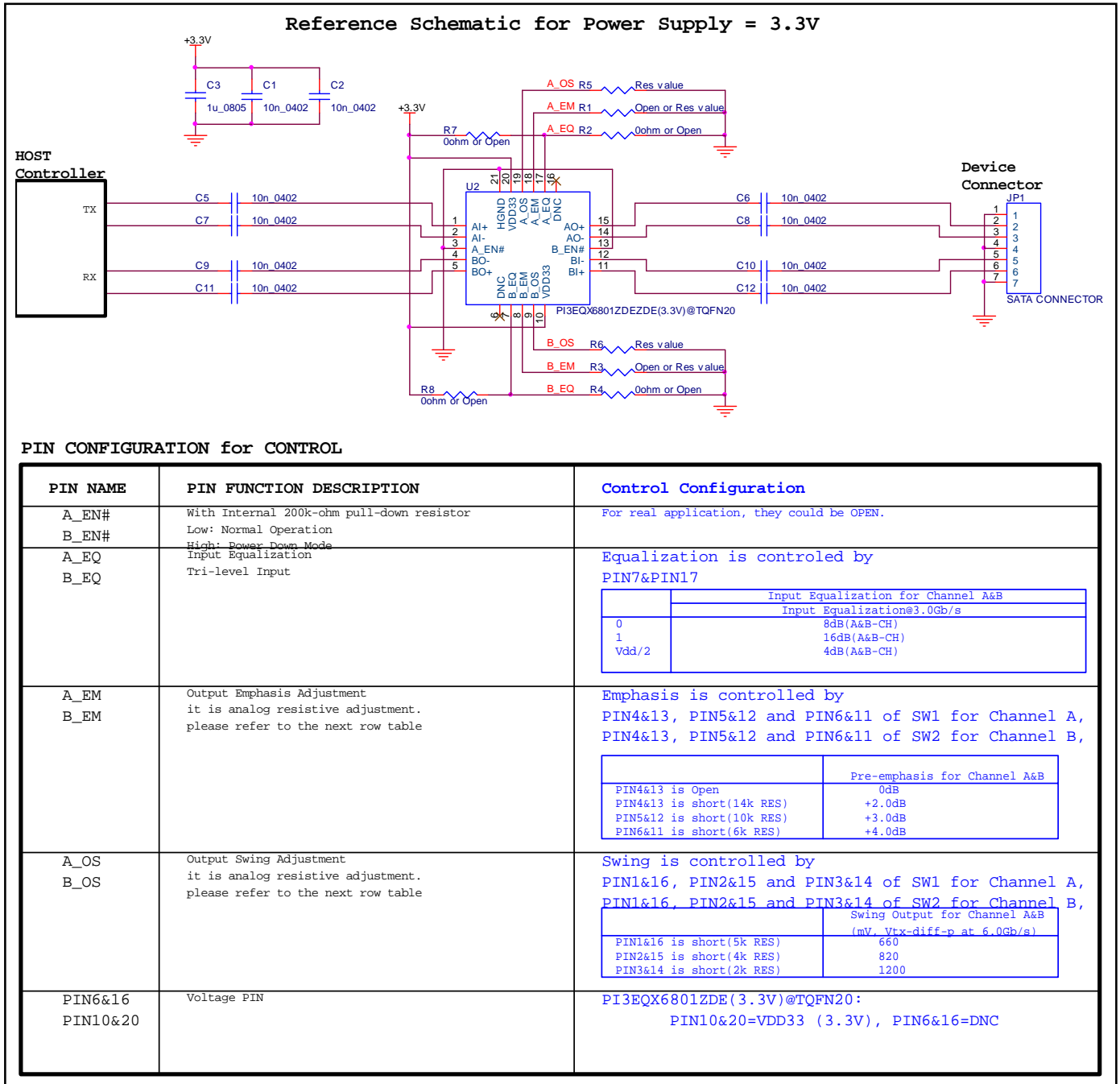

Figure 6a: Typical Application Circuit of PI3EQX6801ZDE at Power=3.3V

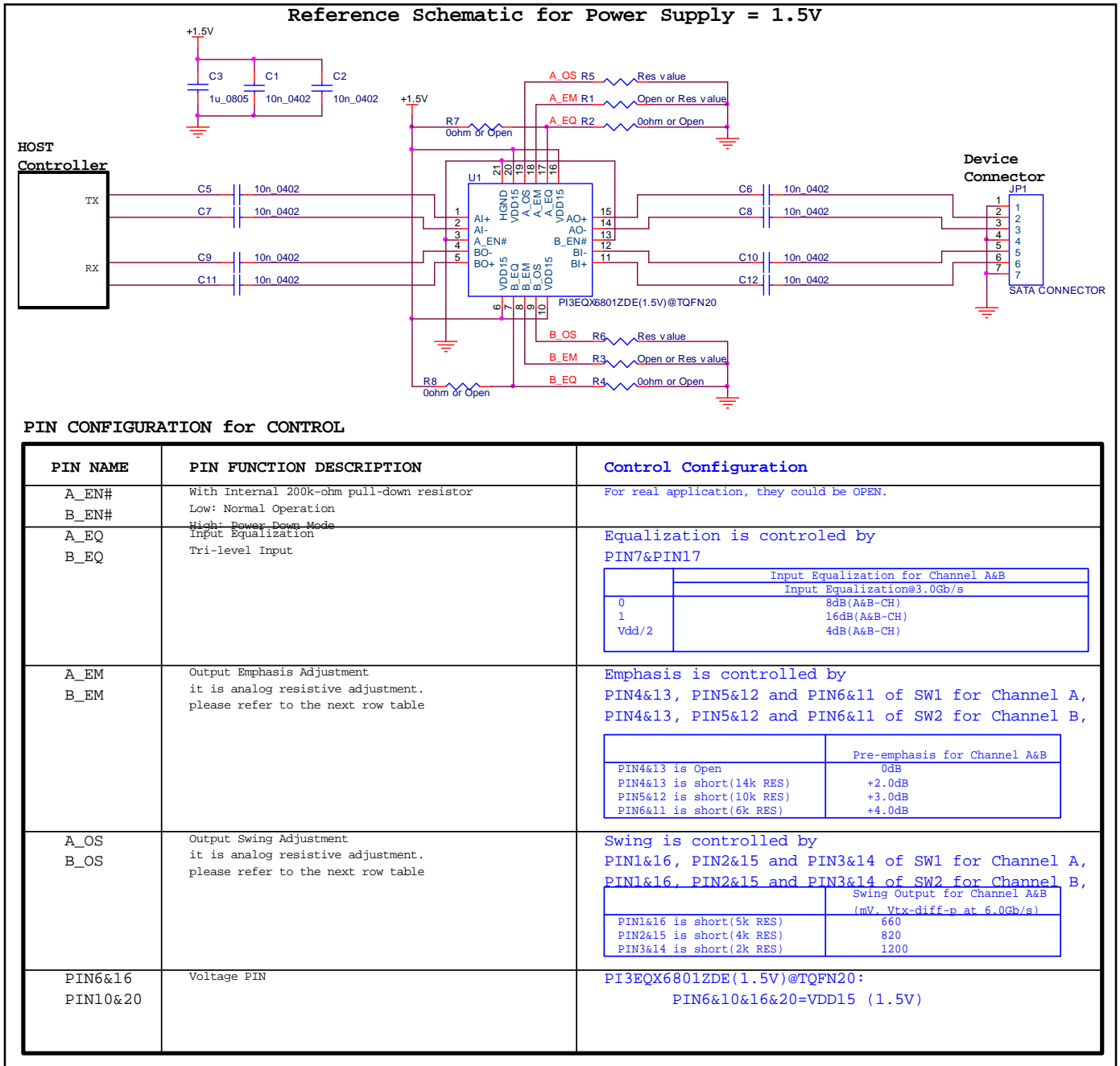

Figure 6b: Typical Application Circuit of PI3EQX6801ZDE at Power=1.2V

PCB Layout Sample

Figure 7 shows the typical layout routing of PI3EQX6801ZDE.

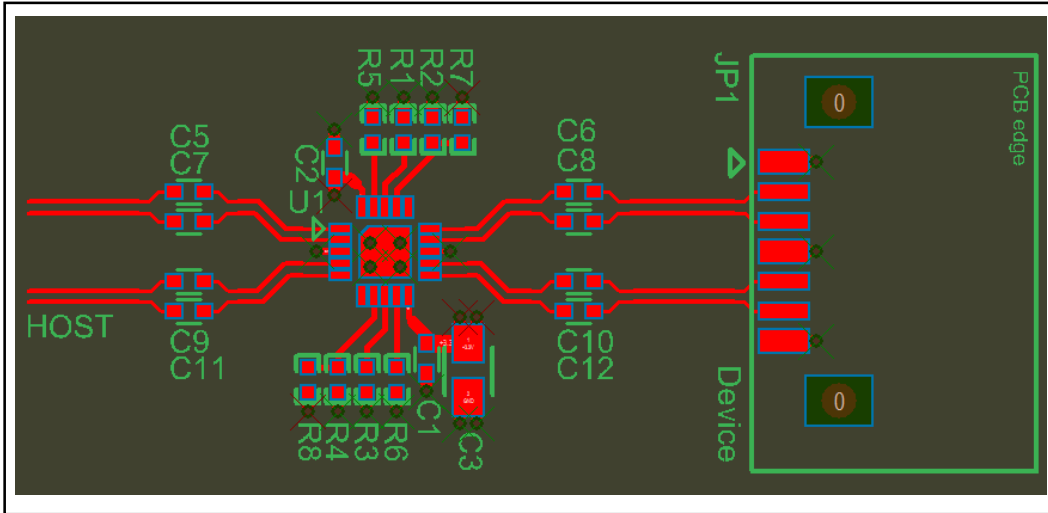

Figure 7a: Typical Layout Routing of PI3EQX6801ZDE at Power=3.3V

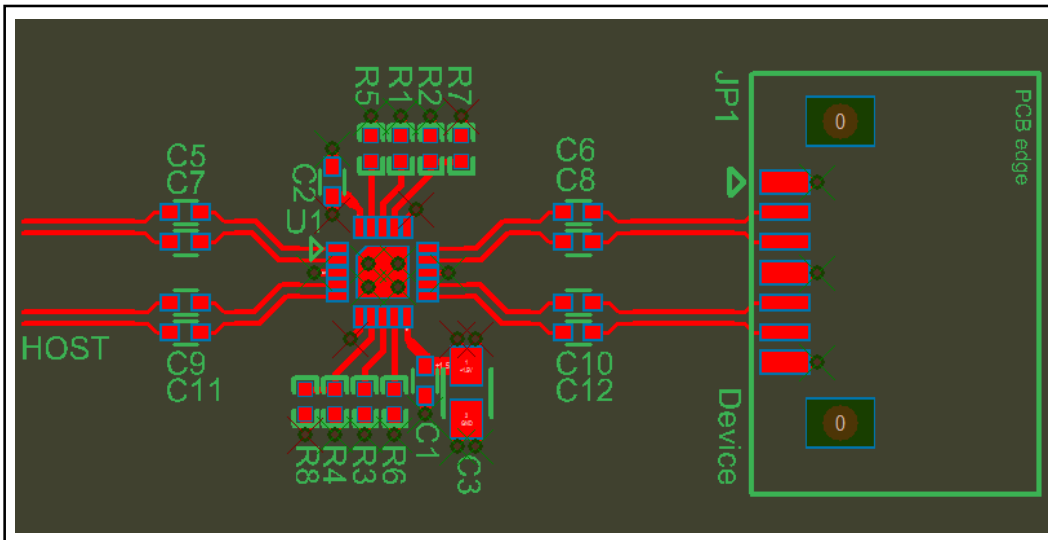

Figure 7b: Typical Layout Routing of PI3EQX6801ZDE at Power=1.5V

History

Version 1.0

Original Version

Nov. 3, 2011