

PCK9448

3.3 V/2.5 V LVCMOS 1 : 12 clock fan-out buffer

Rev. 01 — 29 November 2005

Product data sheet

1. General description

The PCK9448 is a 3.3 V or 2.5 V compatible, 1 : 12 clock fan-out buffer targeted for high performance clock tree applications. With output frequencies up to 350 MHz and output skews less than 150 ps, the device meets the needs of most demanding clock applications.

The PCK9448 is specifically designed to distribute LVCMOS compatible clock signals up to a frequency of 350 MHz. Each output provides a precise copy of the input signal with near zero skew. The output buffers support driving of 50 Ω terminated transmission lines on the incident edge: each is capable of driving either one parallel terminated or two series terminated transmission lines.

Two selectable independent clock inputs are available, providing support of LVCMOS and differential LVPECL clock distribution systems. The PCK9448 $\overline{\text{CLK_STOP}}$ control is synchronous to the falling edge of the input clock. It allows the start and stop of the output clock signal only in a logic LOW state, thus eliminating potential output runt pulses. Applying the OE control will force the outputs into high-impedance mode.

All inputs have an internal pull-up or pull-down resistor preventing unused and open inputs from floating. The device supports a 2.5 V or 3.3 V power supply and an ambient temperature range of $-40\text{ }^{\circ}\text{C}$ to $+85\text{ }^{\circ}\text{C}$.

2. Features

- 12 LVCMOS compatible clock outputs
- Selectable LVCMOS and differential LVPECL compatible clock inputs
- Maximum clock frequency of 350 MHz
- Maximum clock skew of 150 ps
- Synchronous output stop in logic LOW state eliminates output runt pulses
- High-impedance output control
- 3.3 V or 2.5 V power supply
- Drives up to 24 series terminated clock lines
- $T_{\text{amb}} = -40\text{ }^{\circ}\text{C}$ to $+85\text{ }^{\circ}\text{C}$
- Available in LQFP32 package
- Supports clock distribution in networking, telecommunications, and computer applications

PHILIPS

3. Ordering information

Table 1: Ordering information

Type number	Package		Version
	Name	Description	
PCK9448BD	LQFP32	plastic low profile quad flat package; 32 leads; body 7 × 7 × 1.4 mm	SOT358-1

4. Functional diagram

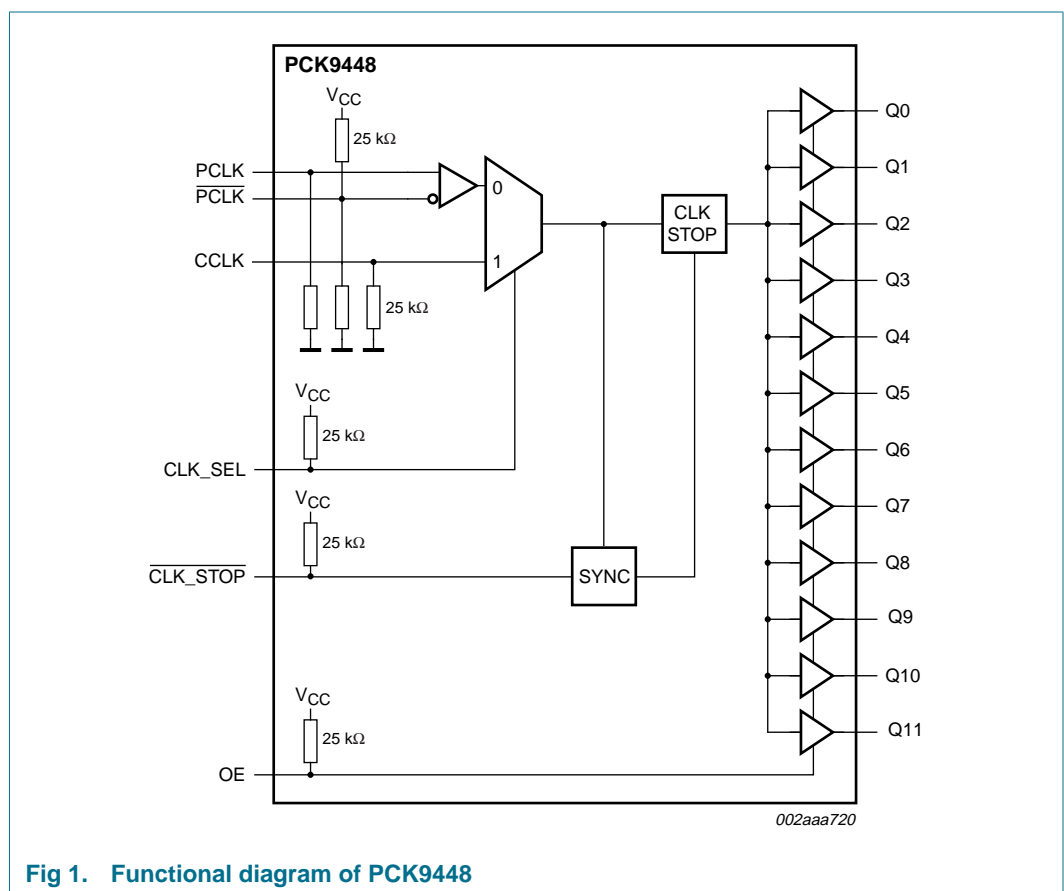
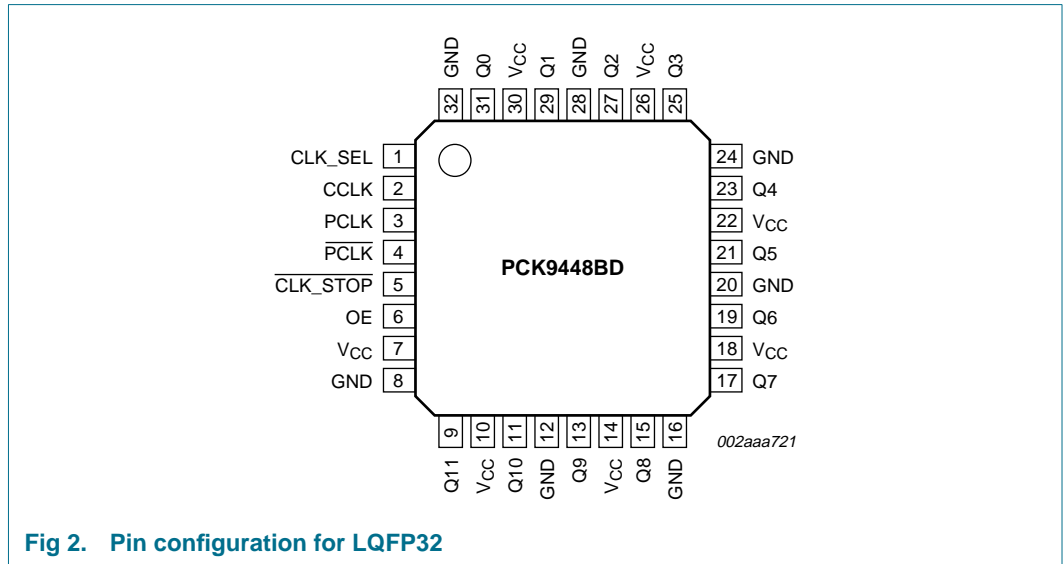

Fig 1. Functional diagram of PCK9448

5. Pinning information

5.1 Pinning



5.2 Pin description

Table 2: Pin description

Symbol	Pin	Type	Description
CLK_SEL	1	I	clock input select
CCLK	2	I	alternative clock signal input
PCLK	3	I	clock signal input
$\overline{\text{PCLK}}$	4	I	clock signal input, active LOW
$\overline{\text{CLK_STOP}}$	5	I	clock output enable/disable, active LOW
OE	6	I	output enable/disable (high-impedance, 3-state)
Q0 to Q11	31, 29, 27, 25, 23, 21, 19, 17, 15, 13, 11, 9	O	clock outputs
GND	8, 12, 16, 20, 24, 28, 32	ground	negative power supply (GND)
V _{CC}	7, 10, 14, 18, 22, 26, 30	power	Positive power supply for I/O and core. All V _{CC} pins must be connected to the positive power supply for correct operation.

6. Functional description

Refer to [Figure 1 “Functional diagram of PCK9448”](#).

6.1 Function table

Table 3: Function table

Control	Default	Logic 0	Logic 1
CLK_SEL	1	PECL differential input selected	CCLK input selected
OE	1	outputs disabled (high-impedance state) [1]	outputs enabled
CLK_STOP	1	outputs synchronously stopped in logic LOW state	outputs active

[1] OE = 0 will high-impedance 3-state all outputs independent of $\overline{\text{CLK_STOP}}$.

7. Limiting values

Table 4: Limiting values

In accordance with the Absolute Maximum Rating System (IEC 60134).

Symbol	Parameter	Conditions	Min	Max	Unit
V_{CC}	supply voltage		-0.3	+3.9	V
V_I	input voltage		-0.3	$V_{CC} + 0.3$	V
V_O	output voltage		-0.3	$V_{CC} + 0.3$	V
I_I	input current		-	±20	mA
I_O	output current		-	±50	mA
T_{stg}	storage temperature		-65	+125	°C

8. Characteristics

8.1 General characteristics

Table 5: General characteristics

Symbol	Parameter	Conditions	Min	Typ	Max	Unit	
V_T	termination voltage (output)		-	$0.5V_{CC}$	-	V	
V_{esd}	electrostatic discharge voltage	Machine Model	[1]	200	-	-	V
		Human Body Model	[2]	2000	-	-	V
$I_{latch(prot)}$	latch-up protection current		200	-	-	mA	
C_{PD}	power dissipation capacitance	per output	-	10	-	pF	
C_i	input capacitance	inputs	-	4.0	-	pF	

[1] 200 pF capacitor discharged via a 10 Ω resistor and a 0.75 μ H inductor.

[2] 100 pF capacitor discharged via a 1.5 k Ω resistor.

8.2 Static characteristics

Table 6: Static characteristics (3.3 V)

$T_{amb} = -40\text{ }^{\circ}\text{C}$ to $+85\text{ }^{\circ}\text{C}$; $V_{CC} = 3.3\text{ V} \pm 5\%$; unless otherwise specified.

Symbol	Parameter	Conditions	Min	Typ	Max	Unit
V_{IH}	HIGH-state input voltage	LVCMOS	2.0	-	$V_{CC} + 0.3$	V
V_{IL}	LOW-state input voltage	LVCMOS	-0.3	-	+0.8	V
V_{OH}	HIGH-state output voltage	$I_{OH} = -24\text{ mA}$	[2] 2.4	-	-	V
V_{OL}	LOW-state output voltage	$I_{OL} = 24\text{ mA}$	[2] -	-	0.55	V
		$I_{OL} = 12\text{ mA}$	-	-	0.30	V
$V_{i(p-p)}$	peak-to-peak input voltage (PCLK)	LVPECL	250	-	-	mV
V_{ICR} [1]	common-mode input voltage range (PCLK)	LVPECL	1.1	-	$V_{CC} - 0.6$	V
Z_o	output impedance		-	17	-	Ω
I_I	input current	$V_I = V_{CC}$ or GND	[3] -	-	300	μA
$I_{q(max)}$	maximum quiescent current	all V_{CC} pins	[4] -	-	2.0	mA

- [1] V_{ICR} (DC) is the cross point of the differential input signal. Functional operation is obtained when the cross point is within the V_{ICR} range and the input swing lies within the $V_{i(p-p)}$ (DC) specification.
- [2] The PCK9448 is capable of driving 50 Ω transmission lines on the incident edge. Each output drives one 50 Ω parallel terminated transmission line to a termination voltage of V_T . Alternatively, the device drives up to two 50 Ω series terminated transmission lines ($V_{CC} = 3.3\text{ V}$) or one 50 Ω series terminated transmission line (for $V_{CC} = 2.5\text{ V}$).
- [3] Inputs have pull-down or pull-up resistors affecting the input current.
- [4] $I_{q(max)}$ is the DC current consumption of the device with all outputs open and the input in its default state or open.

Table 7: Static characteristics (2.5 V)

$T_{amb} = -40\text{ }^{\circ}\text{C}$ to $+85\text{ }^{\circ}\text{C}$; $V_{CC} = 2.5\text{ V} \pm 5\%$; unless otherwise specified.

Symbol	Parameter	Conditions	Min	Typ	Max	Unit
V_{IH}	HIGH-state input voltage	LVCMOS	1.7	-	$V_{CC} + 0.3$	V
V_{IL}	LOW-state input voltage	LVCMOS	-0.3	-	+0.7	V
V_{OH}	HIGH-state output voltage	$I_{OH} = -15\text{ mA}$	[2] 1.8	-	-	V
V_{OL}	LOW-state output voltage	$I_{OL} = 15\text{ mA}$	-	-	0.6	V
$V_{i(p-p)}$	peak-to-peak input voltage (PCLK)	LVPECL	250	-	-	mV
V_{ICR} [1]	common-mode input voltage range (PCLK)	LVPECL	1.0	-	$V_{CC} - 0.7$	V
Z_o	output impedance		-	19	-	Ω
I_I	input current	$V_I = V_{CC}$ or GND	[3] -	-	300	μA
$I_{q(max)}$	maximum quiescent current	all V_{CC} pins	[4] -	-	2.0	mA

- [1] V_{ICR} (DC) is the cross point of the differential input signal. Functional operation is obtained when the cross point is within the V_{ICR} range and the input swing lies within the $V_{i(p-p)}$ (DC) specification.
- [2] The PCK9448 is capable of driving 50 Ω transmission lines on the incident edge. Each output drives one 50 Ω parallel terminated transmission line to a termination voltage of V_T . Alternatively, the device drives one 50 Ω series terminated transmission line per output at $V_{CC} = 2.5\text{ V}$.
- [3] Inputs have pull-down or pull-up resistors affecting the input current.
- [4] $I_{q(max)}$ is the DC current consumption of the device with all outputs open and the input in its default state or open.

8.3 Dynamic characteristics

Table 8: Dynamic characteristics (3.3 V)

$T_{amb} = -40\text{ }^{\circ}\text{C}$ to $+85\text{ }^{\circ}\text{C}$; $V_{CC} = 3.3\text{ V} \pm 5\%$; unless otherwise specified. [1]

Symbol	Parameter	Conditions	Min	Typ	Max	Unit
$V_{i(p-p)}$	input voltage (peak-to-peak value) (PCLK, PCLK)	LVPECL	400	-	1000	mV
V_{ICR} [2]	common-mode input voltage range (PCLK, PCLK)	LVPECL	1.3	-	$V_{CC} - 0.8$	V
f_o	output frequency		0	-	350	MHz
f_i	input frequency		0	-	350	MHz
$t_{sk(o)}$	output skew time		-	-	150	ps
$t_{sk(pr)}$	process skew time	part-to-part	-	-	2.0	ns
δ_o	output duty cycle	$f_o < 170\text{ MHz}$; $\delta_{ref} = 50\%$	45	50	55	%
t_{PLH}	LOW-to-HIGH propagation delay	PCLK to any Q	1.6	-	3.6	ns
		CCLK to any Q	1.3	-	3.3	ns
t_{PHL}	HIGH-to-LOW propagation delay	PCLK to any Q	1.6	-	3.6	ns
		CCLK to any Q	1.3	-	3.3	ns
t_{PLZ}	LOW to OFF-state propagation delay	OE to any Q	-	-	11	ns
t_{PHZ}	HIGH to OFF-state propagation delay	OE to any Q	-	-	11	ns
t_{PZL}	OFF-state to LOW propagation delay	OE to any Q	-	-	11	ns
t_{PZH}	OFF-state to HIGH propagation delay	OE to any Q	-	-	11	ns
t_{su}	setup time	CCLK to $\overline{\text{CLK_STOP}}$	[3] 0.0	-	-	ns
		PCLK to $\overline{\text{CLK_STOP}}$	[3] 0.0	-	-	ns
t_h	hold time	CCLK to $\overline{\text{CLK_STOP}}$	[3] 1.0	-	-	ns
		PCLK to $\overline{\text{CLK_STOP}}$	[3] 1.5	-	-	ns
t_r	rise time	output; 0.55 V to 2.4 V	0.1	-	1.0	ns
		CCLK input; 0.8 V to 2.0 V	-	-	1.0 [4]	ns
t_f	fall time	output; 2.4 V to 0.55 V	0.1	-	1.0	ns
		CCLK input; 2.0 V to 0.8 V	-	-	1.0 [4]	ns

[1] Dynamic characteristics apply for parallel output termination of $50\ \Omega$ to V_T .

[2] V_{ICR} (AC) is the cross-point of the differential input signal. Normal AC operation is obtained when the cross-point is within the V_{ICR} range and the input swing lies within the $V_{i(p-p)}$ (AC) specification. Violation of V_{ICR} or $V_{i(p-p)}$ impacts static phase offset.

[3] Setup and hold times are referenced to the falling edge of the selected clock signal input.

[4] Violation of the 1.0 ns maximum input rise and fall time limit will affect the device propagation delay, device-to-device skew, reference input pulse width, output duty cycle, and maximum frequency specifications.

Table 9: Dynamic characteristics (2.5 V)

$T_{amb} = -40\text{ }^{\circ}\text{C}$ to $+85\text{ }^{\circ}\text{C}$; $V_{CC} = 2.5\text{ V} \pm 5\%$; unless otherwise specified. [1]

Symbol	Parameter	Conditions	Min	Typ	Max	Unit	
$V_{i(p-p)}$	input voltage (peak-to-peak value) (PCLK, $\overline{\text{PCLK}}$)	LVPECL	400	-	1000	mV	
V_{ICR} [2]	common-mode input voltage range (PCLK, $\overline{\text{PCLK}}$)	LVPECL	1.2		$V_{CC} - 0.8$	V	
f_i	input frequency		0	-	350	MHz	
f_o	output frequency		0	-	350	MHz	
$t_{sk(o)}$	output skew time	output-to-output	[3]	-	150	ps	
$t_{sk(pr)}$	process skew time	part-to-part; PCLK or CCLK to any Q	-	-	2.7	ns	
δ_o	output duty cycle	$\delta_{ref} = 50\%$	45	50	60	%	
t_{PLH}	LOW-to-HIGH propagation delay	PCLK to any Q	1.5	-	4.2	ns	
		CCLK to any Q	1.7	-	4.4	ns	
t_{PHL}	HIGH-to-LOW propagation delay	PCLK to any Q	1.5	-	4.2	ns	
		CCLK to any Q	1.7	-	4.4	ns	
t_{PLZ}	LOW to OFF-state propagation delay	OE to any Q	-	-	11	ns	
t_{PHZ}	HIGH to OFF-state propagation delay	OE to any Q	-	-	11	ns	
t_{PZL}	OFF-state to LOW propagation delay	OE to any Q	-	-	11	ns	
t_{PZH}	OFF-state to HIGH propagation delay	OE to any Q	-	-	11	ns	
t_{su}	setup time	CCLK to $\overline{\text{CLK_STOP}}$	[4]	0.0	-	-	ns
		PCLK to $\overline{\text{CLK_STOP}}$	[4]	0.0	-	-	ns
t_h	hold time	CCLK to $\overline{\text{CLK_STOP}}$	[4]	1.0	-	-	ns
		PCLK to $\overline{\text{CLK_STOP}}$	[4]	1.5	-	-	ns
t_r	rise time	input CCLK; 0.8 V to 2.0 V	-	-	1.0	ns	
		output; 0.6 V to 1.8 V	0.1	-	1.0	ns	
t_f	fall time	input CCLK; 2.0 V to 0.8 V	-	-	1.0	ns	
		output; 1.8 V to 0.6 V	0.1	-	1.0	ns	

- [1] Dynamic characteristics apply for parallel output termination of $50\ \Omega$ to V_T .
- [2] V_{ICR} (AC) is the cross-point of the differential input signal. Normal AC operation is obtained when the cross-point is within the V_{ICR} range and the input swing lies within the $V_{i(p-p)}$ (AC) specification. Violation of V_{ICR} or $V_{i(p-p)}$ impacts static phase offset.
- [3] See [Section 9 "Application information"](#) for part-to-part skew calculation.
- [4] Setup and hold times are referenced to the falling edge of the selected clock signal input.

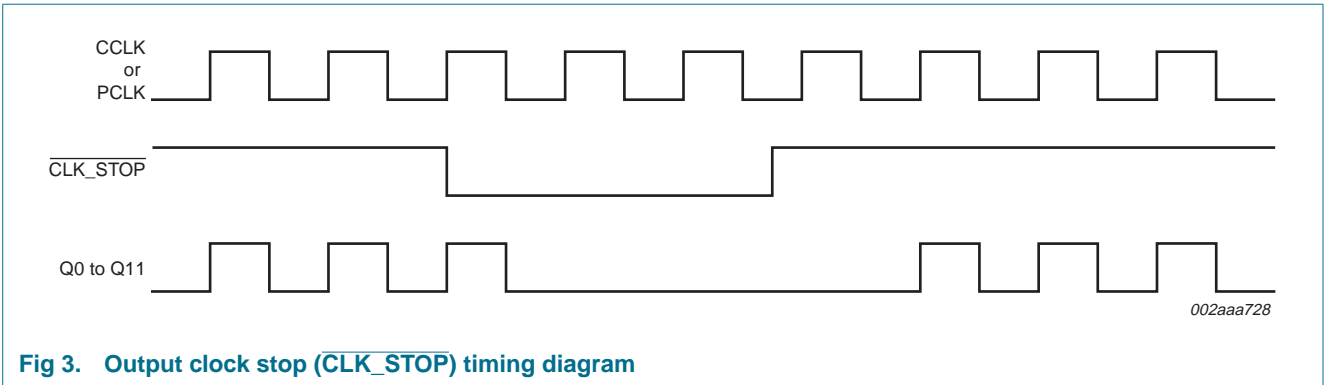

Fig 3. Output clock stop (CLK_STOP) timing diagram

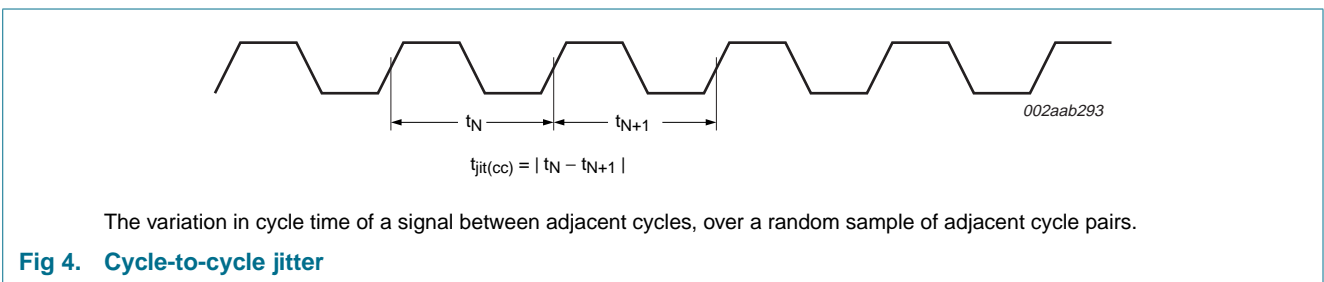

Fig 4. Cycle-to-cycle jitter

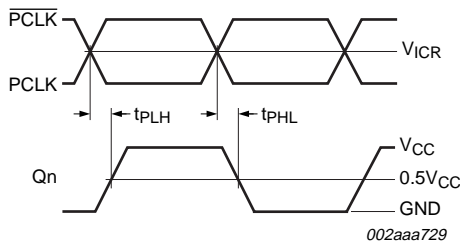

Fig 5. Propagation delay test reference (PCLK/PCLK to Qn)

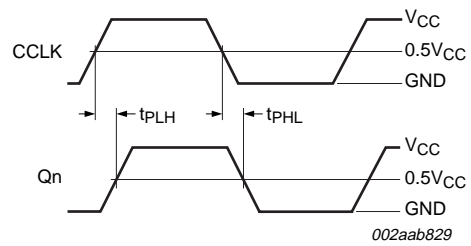

Fig 6. Propagation delay test reference (CCLK to Qn)

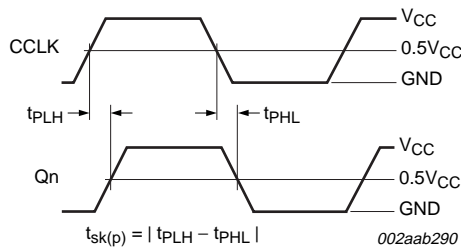
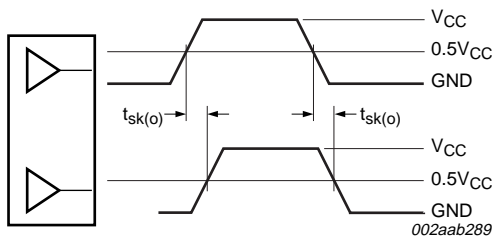
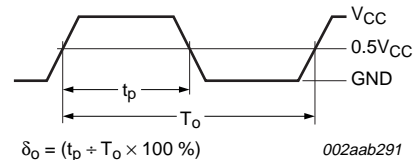

Fig 7. Pulse skew time ($t_{sk(p)}$) test reference



The pin-to-pin skew is defined as the worst-case difference in propagation delay between any similar delay path within a single device.

Fig 8. Output skew time ($t_{sk(o)}$)



$$T_o = \frac{1}{f_o}$$

The time from the output controlled edge to the non-controlled edge, divided by the time between output controlled edges, expressed as a percentage.

Fig 9. Output duty cycle (δ_o)

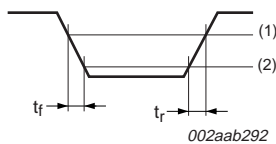

- (1) 2.4 V ($V_{CC} = 3.3$ V)
- 1.8 V ($V_{CC} = 2.5$ V)
- (2) 0.55 V ($V_{CC} = 3.3$ V)
- 0.6 V ($V_{CC} = 2.5$ V)

Fig 10. Output transition time test reference

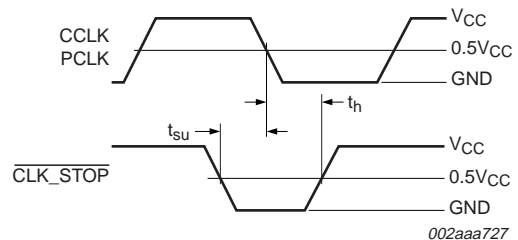

Fig 11. Setup and hold time (t_{su} , t_h)

9. Application information

9.1 Driving transmission lines

The PCK9448 clock driver was designed to drive high speed signals in a terminated transmission line environment. To provide the optimum flexibility to the user, the output drivers were designed to exhibit the lowest impedance possible. With an output impedance of $17\ \Omega$ ($V_{CC} = 3.3\text{ V}$), the outputs can drive either parallel or series terminated transmission lines.

In most high performance clock networks, point-to-point distribution of signals is the method of choice. In a point-to-point scheme, either series terminated or parallel terminated transmission lines can be used. The parallel technique terminates the signal at the end of the line with a $50\ \Omega$ resistance to $0.5V_{CC}$. This technique draws a fairly high level of DC current, and thus only a single terminated line can be driven by each output of the PCK9448 clock driver. For the series terminated case, however, there is no DC current draw, thus the outputs can drive multiple series terminated lines. [Figure 12](#), illustrates an output driving a single series terminated line versus two series terminated lines in parallel. When taken to its extreme, the fan-out of the PCK9448 clock driver is effectively doubled due to its capability to drive multiple lines.

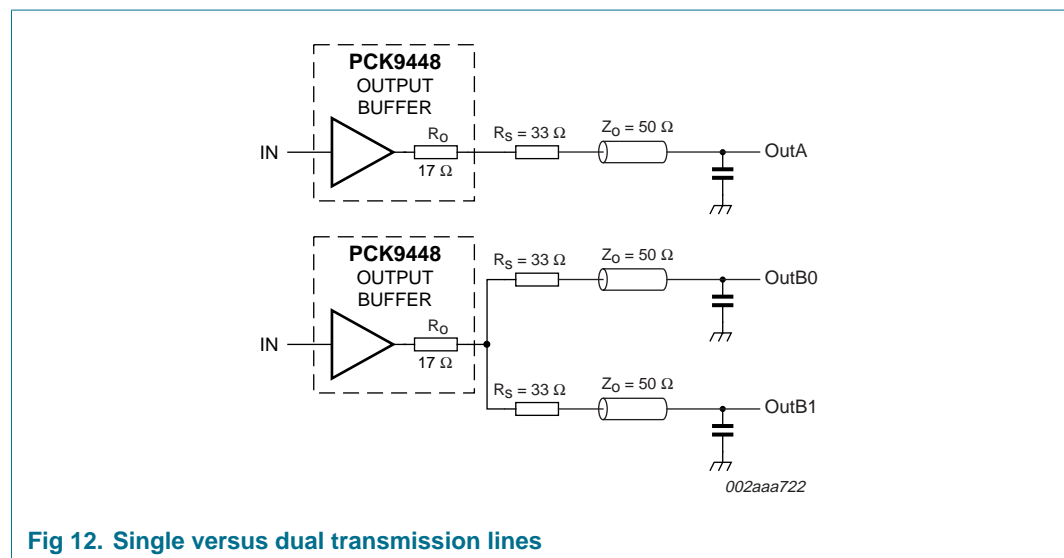

Fig 12. Single versus dual transmission lines

The waveform plots of [Figure 13](#) show simulation results of an output driving a single line versus two lines. In both cases the drive capability of the PCK9448 output buffer is more than sufficient to drive 50 Ω transmission lines on the incident edge. Note from the delay measurement in the simulations a delta of only 43 ps exists between the two differently loaded outputs. This suggests that the dual line driving need not be used exclusively to maintain the tight output-to-output skew of the PCK9448. The output waveform in [Figure 13](#) shows a step in the waveform; this step is caused by the impedance mismatch seen looking into the driver. The parallel combination of the 33 Ω series resistor plus the output impedance does not match the parallel combination of the line impedances. The voltage wave launched down the two lines will equal:

$$V_L = V_s \left(\frac{Z_o}{R_s + R_o + Z_o} \right)$$

$$\begin{aligned} Z_o &= 50 \Omega \parallel 50 \Omega \\ R_s &= 33 \Omega \parallel 33 \Omega \\ R_o &= 17 \Omega \end{aligned}$$

$$V_L = 3.0 \left(\frac{25}{16.5 + 17 + 25} \right) = 1.28 \text{ V}$$

At the load end the voltage will double, due to the near unity reflection coefficient, to 2.5 V. It will then increment towards the quiescent 3.0 V in steps separated by one round trip delay (in this case 4.0 ns).

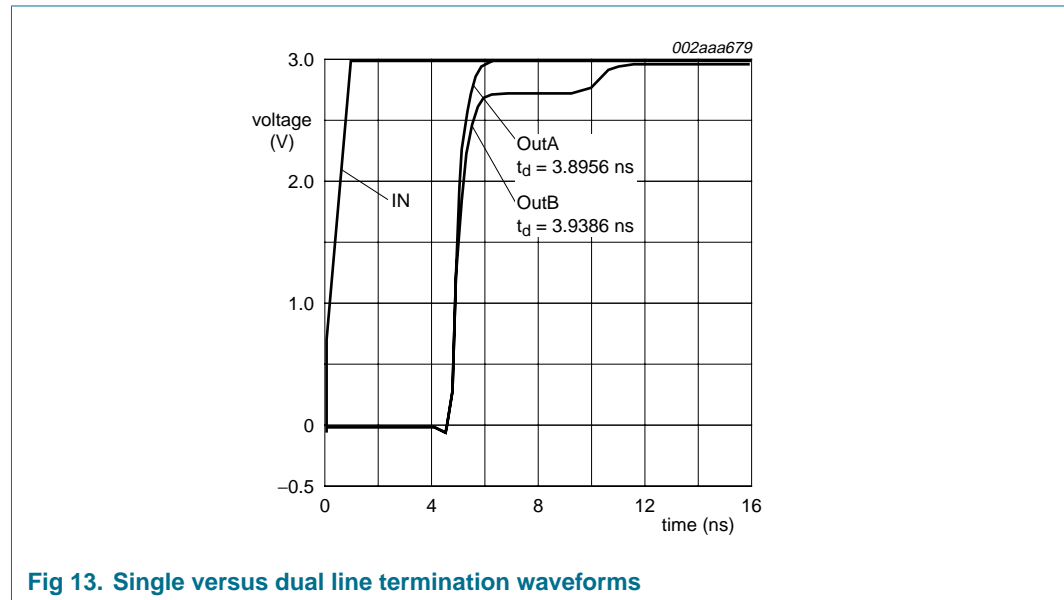

Fig 13. Single versus dual line termination waveforms

Since this step is well above the threshold region it will not cause any false clock triggering, however designers may be uncomfortable with unwanted reflections on the line. To better match the impedances when driving multiple lines, the situation in [Figure 14](#) should be used. In this case the series terminating resistors are reduced such that when the parallel combination is added to the output buffer impedance the line impedance is perfectly matched.

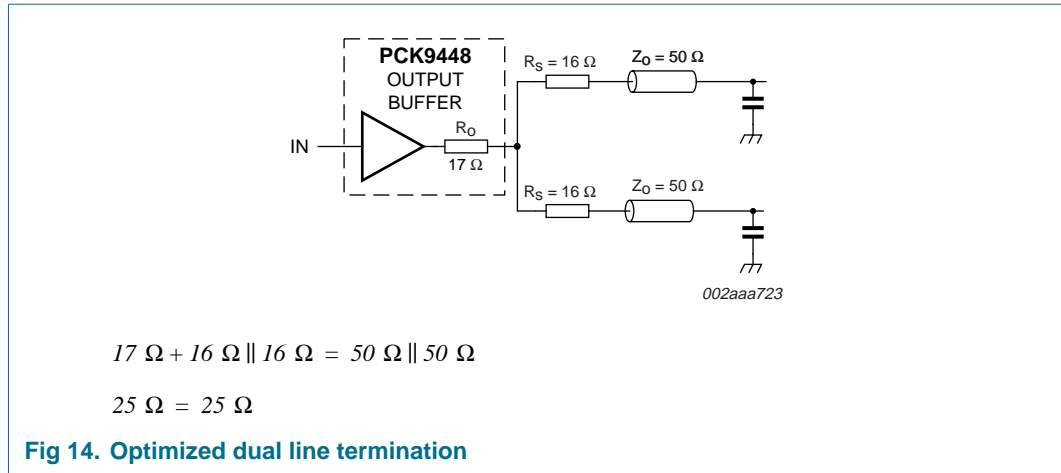

Fig 14. Optimized dual line termination

9.2 Power consumption of the PCK9448 and thermal management

The PCK9448 dynamic electrical (AC) specification is guaranteed for the entire operating frequency range up to 350 MHz. The PCK9448 power consumption and the associated long-term reliability may decrease the maximum frequency limit, depending on operating condition such as clock frequency, supply voltage, output loading, ambient temperature, vertical convection and thermal conductivity of package and board. This section describes the impact of these parameters on the junction temperature and gives a guideline to estimate the PCK9448 die junction temperature and the associated device reliability. The long-term device reliability is a function of the die temperature; refer to [Table 10](#).

Table 10: Die junction temperature and MTBF

Junction temperature (°C)	MTBF (years)
100	20.4
110	9.1
120	4.2
130	2.0

Increased power consumption will increase the die junction temperature and impact the device reliability (MTBF). According to the system-defined tolerable MTBF, the die junction temperature of the PCK9448 needs to be controlled and the thermal impedance of the board/package should be optimized. The power dissipated in the PCK9448 is represented in [Equation 1](#).

$$P_{tot} = \left[I_{q(max)} + V_{CC} \times f_{clk} \times \left(N \times C_{PD} + \sum_M C_L \right) \right] \times V_{CC} \tag{1}$$

Where $I_{q(max)}$ is the static current consumption of the PCK9448, C_{PD} is the power dissipation capacitance per output, $(M)\Sigma C_L$ represents the external capacitive output load, N is the number of active outputs (N is always 12 in the case of the PCK9448). The PCK9448 supports driving transmission lines to maintain high signal integrity and tight timing parameters. Any transmission line will hide the latched capacitive load at the end of the board trace, therefore, ΣC_L is zero for controlled transmission line systems and can be eliminated from [Equation 1](#). Using parallel termination output termination results in [Equation 2](#) for power dissipation.

$$P_{tot} = V_{CC} \times \left[I_{q(max)} + V_{CC} \times f_{clk} \times \left(N \times C_{PD} + \sum_M C_L \right) \right] \quad (2)$$

$$+ \sum_P [\delta_o \times I_{OH} \times (V_{CC} - V_{OH}) + (1 - DC_Q) \times I_{OL} \times V_{OL}]$$

In [Equation 2](#), P stands for the number of outputs with a parallel or Thevenin termination; V_{OL} , I_{OL} , V_{OH} and I_{OH} are a function of the output termination technique; δ_o is the clock signal duty cycle. If transmission lines are used, ΣC_L is zero in [Equation 2](#) and can be eliminated. In general, the use of controlled transmission line techniques eliminates the impact of the lumped capacitive loads at the end lines and greatly reduces the power dissipation of the device. [Equation 3](#) describes the die junction temperature T_j as a function of the power consumption.

$$T_j = T_{amb} + P_{tot} \times R_{th(j-a)} \quad (3)$$

Where $R_{th(j-a)}$ is the thermal impedance of the package (junction-to-ambient) and T_{amb} is the ambient temperature. According to [Table 10](#), the junction temperature can be used to estimate the long-term device reliability. Further, combining [Equation 1](#) and [Equation 2](#) results in a maximum operating frequency for the PCK9448 in a series terminated transmission line system, [Equation 4](#).

$$f_{clk(max)} = \frac{1}{C_{PD} \times N \times V_{CC}} \times \left[\frac{T_{j(max)} - T_{amb}}{R_{th(j-a)}} - (I_{q(max)} \times V_{CC}) \right] \quad (4)$$

$T_{j(max)}$ should be selected according to the MTBF system requirements and [Table 10](#). $R_{th(j-a)}$ can be derived from [Table 11](#). The $R_{th(j-a)}$ represent data based on 1S2P boards; using 2S2P boards will result in a lower thermal impedance than indicated below.

Table 11: Thermal package impedance of the LQFP32

Convection (LFPM)	$R_{th(j-a)}$ (°C/W) (1P2S board)	$R_{th(j-a)}$ (°C/W) (2P2S board)
still air	88	61
100	76	56
200	71	54
300	68	53
400	66	52
500	60	49

If the calculated maximum frequency is below 350 MHz, it becomes the upper clock speed limit for the given application conditions. The following four derating charts describe the safe frequency operation range for the PCK9448. The charts were calculated for a maximum tolerable die junction temperature of 110 °C (120 °C), corresponding to an estimated MTBF of 9.1 years (4 years), a supply voltage of 3.3 V and series terminated transmission line or capacitive loading. Depending on a given set of these operating conditions and the available device convection, a decision on the maximum operating frequency can be made.

10. Test information

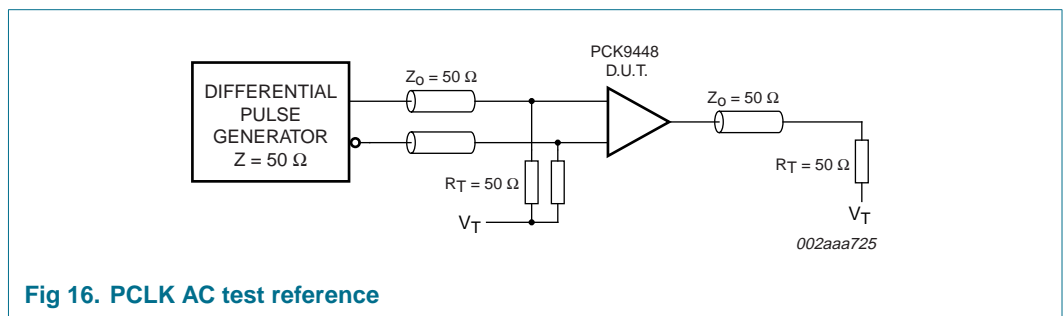
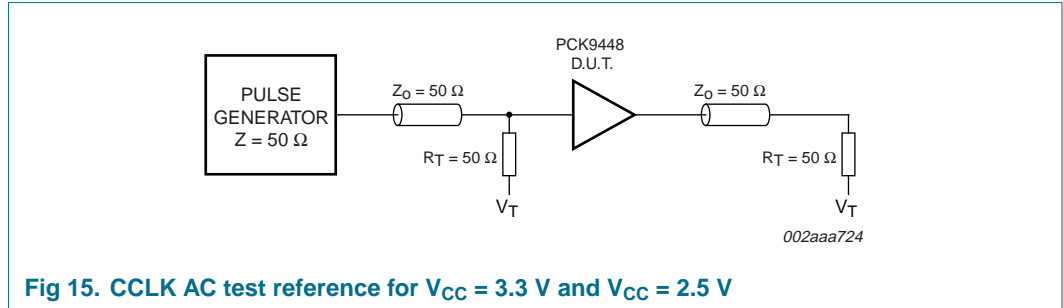

11. Package outline

LQFP32: plastic low profile quad flat package; 32 leads; body 7 x 7 x 1.4 mm

SOT358-1

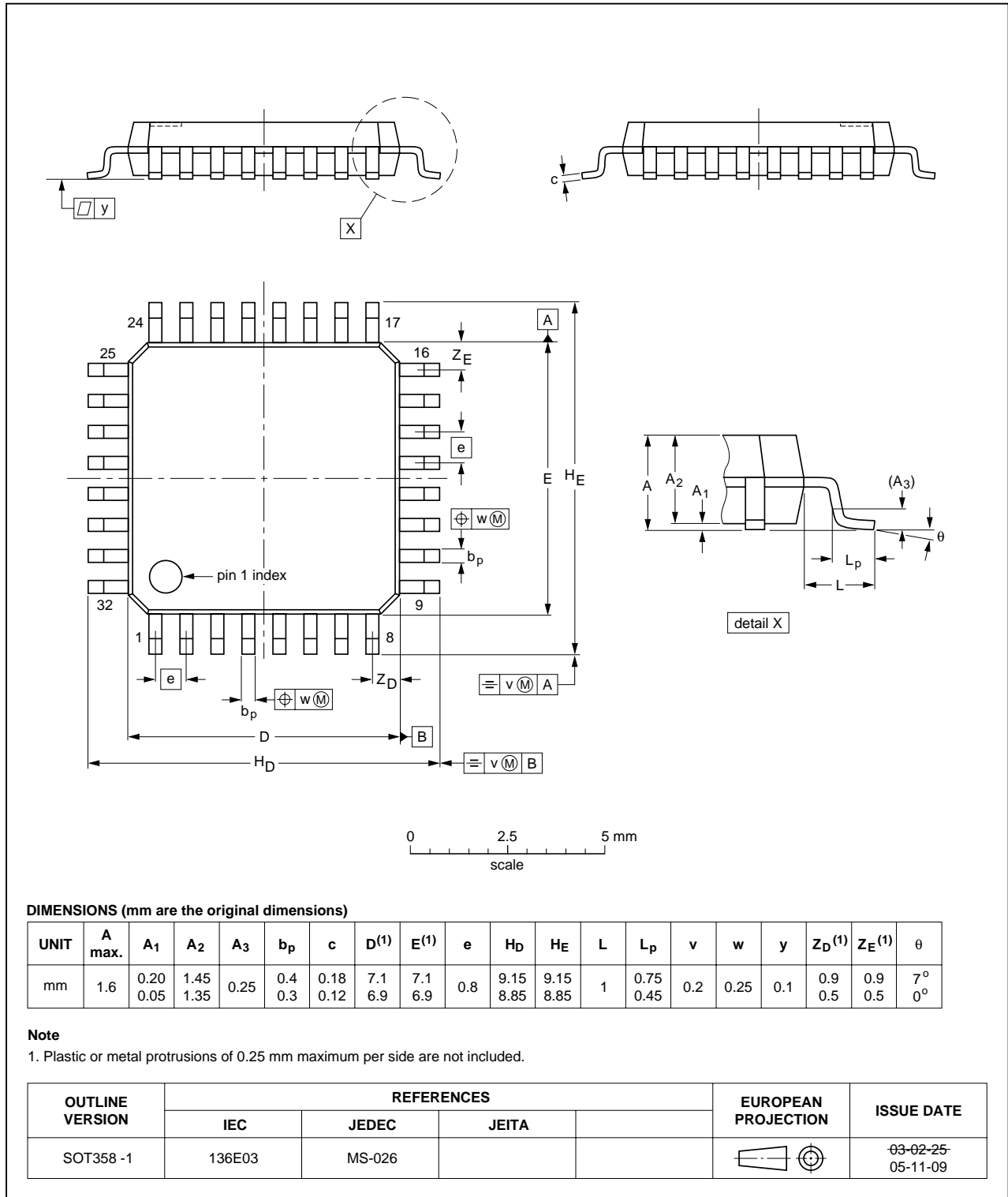

Fig 17. Package outline SOT358-1 (LQFP32)

12. Soldering

12.1 Introduction to soldering surface mount packages

This text gives a very brief insight to a complex technology. A more in-depth account of soldering ICs can be found in our *Data Handbook IC26; Integrated Circuit Packages* (document order number 9398 652 90011).

There is no soldering method that is ideal for all surface mount IC packages. Wave soldering can still be used for certain surface mount ICs, but it is not suitable for fine pitch SMDs. In these situations reflow soldering is recommended.

12.2 Reflow soldering

Reflow soldering requires solder paste (a suspension of fine solder particles, flux and binding agent) to be applied to the printed-circuit board by screen printing, stencilling or pressure-syringe dispensing before package placement. Driven by legislation and environmental forces the worldwide use of lead-free solder pastes is increasing.

Several methods exist for reflowing; for example, convection or convection/infrared heating in a conveyor type oven. Throughput times (preheating, soldering and cooling) vary between 100 seconds and 200 seconds depending on heating method.

Typical reflow peak temperatures range from 215 °C to 270 °C depending on solder paste material. The top-surface temperature of the packages should preferably be kept:

- below 225 °C (SnPb process) or below 245 °C (Pb-free process)
 - for all BGA, HTSSON..T and SSOP..T packages
 - for packages with a thickness ≥ 2.5 mm
 - for packages with a thickness < 2.5 mm and a volume ≥ 350 mm³ so called thick/large packages.
- below 240 °C (SnPb process) or below 260 °C (Pb-free process) for packages with a thickness < 2.5 mm and a volume < 350 mm³ so called small/thin packages.

Moisture sensitivity precautions, as indicated on packing, must be respected at all times.

12.3 Wave soldering

Conventional single wave soldering is not recommended for surface mount devices (SMDs) or printed-circuit boards with a high component density, as solder bridging and non-wetting can present major problems.

To overcome these problems the double-wave soldering method was specifically developed.

If wave soldering is used the following conditions must be observed for optimal results:

- Use a double-wave soldering method comprising a turbulent wave with high upward pressure followed by a smooth laminar wave.
- For packages with leads on two sides and a pitch (e):
 - larger than or equal to 1.27 mm, the footprint longitudinal axis is **preferred** to be parallel to the transport direction of the printed-circuit board;

- smaller than 1.27 mm, the footprint longitudinal axis **must** be parallel to the transport direction of the printed-circuit board.

The footprint must incorporate solder thieves at the downstream end.

- For packages with leads on four sides, the footprint must be placed at a 45° angle to the transport direction of the printed-circuit board. The footprint must incorporate solder thieves downstream and at the side corners.

During placement and before soldering, the package must be fixed with a droplet of adhesive. The adhesive can be applied by screen printing, pin transfer or syringe dispensing. The package can be soldered after the adhesive is cured.

Typical dwell time of the leads in the wave ranges from 3 seconds to 4 seconds at 250 °C or 265 °C, depending on solder material applied, SnPb or Pb-free respectively.

A mildly-activated flux will eliminate the need for removal of corrosive residues in most applications.

12.4 Manual soldering

Fix the component by first soldering two diagonally-opposite end leads. Use a low voltage (24 V or less) soldering iron applied to the flat part of the lead. Contact time must be limited to 10 seconds at up to 300 °C.

When using a dedicated tool, all other leads can be soldered in one operation within 2 seconds to 5 seconds between 270 °C and 320 °C.

12.5 Package related soldering information

Table 12: Suitability of surface mount IC packages for wave and reflow soldering methods

Package [1]	Soldering method	
	Wave	Reflow [2]
BGA, HTSSON..T [3], LBGA, LFBGA, SQFP, SSOP..T [3], TFBGA, VFBGA, XSON	not suitable	suitable
DHVQFN, HBCC, HBGA, HLQFP, HSO, HSOP, HSQFP, HSSON, HTQFP, HTSSOP, HVQFN, HVSON, SMS	not suitable [4]	suitable
PLCC [5], SO, SOJ	suitable	suitable
LQFP, QFP, TQFP	not recommended [5] [6]	suitable
SSOP, TSSOP, VSO, VSSOP	not recommended [7]	suitable
CWQCCN..L [8], PMFP [9], WQCCN..L [8]	not suitable	not suitable

[1] For more detailed information on the BGA packages refer to the (LF)BGA Application Note (AN01026); order a copy from your Philips Semiconductors sales office.

[2] All surface mount (SMD) packages are moisture sensitive. Depending upon the moisture content, the maximum temperature (with respect to time) and body size of the package, there is a risk that internal or external package cracks may occur due to vaporization of the moisture in them (the so called popcorn effect). For details, refer to the Drypack information in the Data Handbook IC26; Integrated Circuit Packages; Section: Packing Methods.

[3] These transparent plastic packages are extremely sensitive to reflow soldering conditions and must on no account be processed through more than one soldering cycle or subjected to infrared reflow soldering with peak temperature exceeding 217 °C ± 10 °C measured in the atmosphere of the reflow oven. The package body peak temperature must be kept as low as possible.

- [4] These packages are not suitable for wave soldering. On versions with the heatsink on the bottom side, the solder cannot penetrate between the printed-circuit board and the heatsink. On versions with the heatsink on the top side, the solder might be deposited on the heatsink surface.
- [5] If wave soldering is considered, then the package must be placed at a 45° angle to the solder wave direction. The package footprint must incorporate solder thieves downstream and at the side corners.
- [6] Wave soldering is suitable for LQFP, QFP and TQFP packages with a pitch (e) larger than 0.8 mm; it is definitely not suitable for packages with a pitch (e) equal to or smaller than 0.65 mm.
- [7] Wave soldering is suitable for SSOP, TSSOP, VSO and VSSOP packages with a pitch (e) equal to or larger than 0.65 mm; it is definitely not suitable for packages with a pitch (e) equal to or smaller than 0.5 mm.
- [8] Image sensor packages in principle should not be soldered. They are mounted in sockets or delivered pre-mounted on flex foil. However, the image sensor package can be mounted by the client on a flex foil by using a hot bar soldering process. The appropriate soldering profile can be provided on request.
- [9] Hot bar soldering or manual soldering is suitable for PMFP packages.

13. Abbreviations

Table 13: Abbreviations

Acronym	Description
ESD	ElectroStatic Discharge
HBM	Human Body Model
MM	Machine Model
MTBF	Mean Time Between Failures
LFPM	Linear Feet Per Minute
LVPECL	Low Voltage Positive Emitter Coupled Logic
LVCMOS	Low Voltage Complementary Metal Oxide Silicon

14. Revision history

Table 14: Revision history

Document ID	Release date	Data sheet status	Change notice	Doc. number	Supersedes
PCK9448_1	20051129	Product data sheet	-	9397 750 12534	-

15. Data sheet status

Level	Data sheet status ^[1]	Product status ^{[2] [3]}	Definition
I	Objective data	Development	This data sheet contains data from the objective specification for product development. Philips Semiconductors reserves the right to change the specification in any manner without notice.
II	Preliminary data	Qualification	This data sheet contains data from the preliminary specification. Supplementary data will be published at a later date. Philips Semiconductors reserves the right to change the specification without notice, in order to improve the design and supply the best possible product.
III	Product data	Production	This data sheet contains data from the product specification. Philips Semiconductors reserves the right to make changes at any time in order to improve the design, manufacturing and supply. Relevant changes will be communicated via a Customer Product/Process Change Notification (CPCN).

[1] Please consult the most recently issued data sheet before initiating or completing a design.

[2] The product status of the device(s) described in this data sheet may have changed since this data sheet was published. The latest information is available on the Internet at URL <http://www.semiconductors.philips.com>.

[3] For data sheets describing multiple type numbers, the highest-level product status determines the data sheet status.

16. Definitions

Short-form specification — The data in a short-form specification is extracted from a full data sheet with the same type number and title. For detailed information see the relevant data sheet or data handbook.

Limiting values definition — Limiting values given are in accordance with the Absolute Maximum Rating System (IEC 60134). Stress above one or more of the limiting values may cause permanent damage to the device. These are stress ratings only and operation of the device at these or at any other conditions above those given in the Characteristics sections of the specification is not implied. Exposure to limiting values for extended periods may affect device reliability.

Application information — Applications that are described herein for any of these products are for illustrative purposes only. Philips Semiconductors make no representation or warranty that such applications will be suitable for the specified use without further testing or modification.

17. Disclaimers

Life support — These products are not designed for use in life support appliances, devices, or systems where malfunction of these products can reasonably be expected to result in personal injury. Philips Semiconductors

19. Contact information

For additional information, please visit: <http://www.semiconductors.philips.com>

For sales office addresses, send an email to: sales.addresses@www.semiconductors.philips.com

customers using or selling these products for use in such applications do so at their own risk and agree to fully indemnify Philips Semiconductors for any damages resulting from such application.

Right to make changes — Philips Semiconductors reserves the right to make changes in the products - including circuits, standard cells, and/or software - described or contained herein in order to improve design and/or performance. When the product is in full production (status 'Production'), relevant changes will be communicated via a Customer Product/Process Change Notification (CPCN). Philips Semiconductors assumes no responsibility or liability for the use of any of these products, conveys no license or title under any patent, copyright, or mask work right to these products, and makes no representations or warranties that these products are free from patent, copyright, or mask work right infringement, unless otherwise specified.

18. Trademarks

Notice — All referenced brands, product names, service names and trademarks are the property of their respective owners.

20. Contents

1	General description	1
2	Features	1
3	Ordering information	2
4	Functional diagram	2
5	Pinning information	3
5.1	Pinning	3
5.2	Pin description	3
6	Functional description	4
6.1	Function table	4
7	Limiting values	4
8	Characteristics	4
8.1	General characteristics	4
8.2	Static characteristics	5
8.3	Dynamic characteristics	6
9	Application information	10
9.1	Driving transmission lines	10
9.2	Power consumption of the PCK9448 and thermal management	12
10	Test information	14
11	Package outline	15
12	Soldering	16
12.1	Introduction to soldering surface mount packages	16
12.2	Reflow soldering	16
12.3	Wave soldering	16
12.4	Manual soldering	17
12.5	Package related soldering information	17
13	Abbreviations	18
14	Revision history	18
15	Data sheet status	19
16	Definitions	19
17	Disclaimers	19
18	Trademarks	19
19	Contact information	19



© Koninklijke Philips Electronics N.V. 2005

All rights are reserved. Reproduction in whole or in part is prohibited without the prior written consent of the copyright owner. The information presented in this document does not form part of any quotation or contract, is believed to be accurate and reliable and may be changed without notice. No liability will be accepted by the publisher for any consequence of its use. Publication thereof does not convey nor imply any license under patent- or other industrial or intellectual property rights.

Date of release: 29 November 2005
Document number: 9397 750 12534

Published in The Netherlands