



TEA2095TE

GreenChip dual synchronous rectifier controller

Rev. 1.1 — 10 April 2020

Product data sheet

1 General description

The TEA2095TE is a new synchronous rectifier (SR) controller IC for switched-mode power supplies. It incorporates an adaptive gate drive method for maximum efficiency at any load.

The TEA2095TE is a dedicated controller IC for synchronous rectification on the secondary side of resonant converters. It has two driver stages for driving the SR MOSFETs, which rectify the outputs of the central tap secondary transformer windings. The two gate driver stages have their own sensing inputs and operate independently.

The TEA2095TE is optimized for efficient operation with very low-ohmic MOSFETs and switching at high frequencies.

The TEA2095TE is fabricated in a silicon-on-insulator (SOI) process.

2 Features and benefits

2.1 Efficiency features

- Adaptive gate drive for maximum efficiency at any load
- Supply current in energy save operation of 90 μ A
- Regulation level of -25 mV for driving low-ohmic MOSFETs

2.2 Application features

- Wide supply voltage range from 4.5 V to 38 V
- Dual synchronous rectification for LLC resonant
- Supports 5 V operation with logic level SR MOSFETs
- Differential inputs for sensing the drain and source voltages of each SR MOSFET
- HSO8 package with exposed die pad
- Discharge of the output capacitor after mains disconnect

2.3 Control features

- SR control without minimum on-time
- Adaptive gate drive for fast turn-off at the end of conduction
- Undervoltage lockout (UVLO) protection with active gate pull-down
- Interlock function to prevent simultaneous conduction of the external MOSFETs
- Supports 1 MHz switching frequency



3 Applications

The TEA2095TE is intended for resonant power supplies. In such applications, it can drive two external synchronous rectifier MOSFETs for the rectification of the voltages on the two secondary windings of the transformer. These MOSFETs replace diodes. It can be used in all power supplies requiring high efficiency:

- Adapters
- Power supplies for desktop PC and all-in-one PC
- Power supplies for television
- Power supplies for servers

4 Ordering information

Table 1. Ordering information

Type number	Package			
	Name	Description	Bond-wire	Version
TEA2095TE/1/S30	HS08	plastic thermal enhanced small outline package; 8 leads; body width 3.9 mm; exposed die pad	Au	SOT786-3
TEA2095TE/1	HS08	plastic thermal enhanced small outline package; 8 leads; body width 3.9 mm; exposed die pad	Cu	SOT786-3

5 Marking

Table 2. Marking

Type number	Marking code
TEA2095TE/1	TEA2095

6 Block diagram

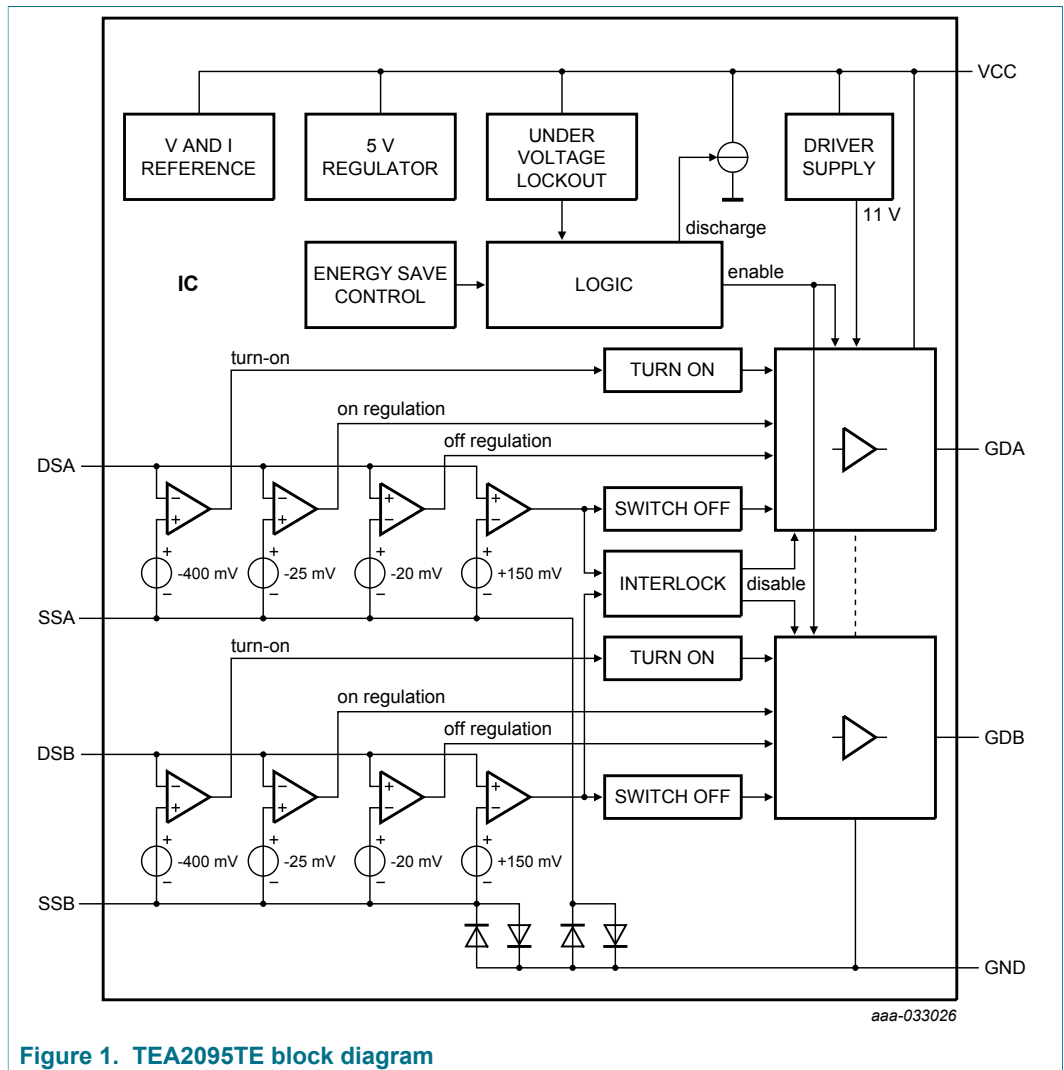

Figure 1. TEA2095TE block diagram

7 Pinning information

7.1 Pinning

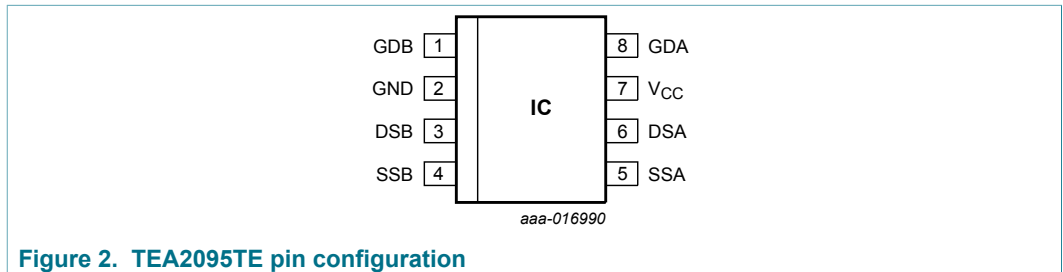

Figure 2. TEA2095TE pin configuration

7.2 Pin description

Table 3. Pin description

Symbol	Pin	Description
GDB	1	gate drive output MOSFET B
GND	2	ground
DSB	3	drain sense input for synchronous timing MOSFET B
SSB	4	source sense input MOSFET B
SSA	5	source sense input MOSFET A
DSA	6	drain sense input for synchronous timing MOSFET A
V _{CC}	7	supply voltage
GDA	8	gate drive output MOSFET A

8 Functional description

8.1 Introduction

The TEA2095TE is a controller IC for synchronous rectification. It is perfectly suited to be used in resonant applications. It can drive two synchronous rectifier MOSFETs on the secondary side of the central tap transformer winding. Figure 3 shows a typical configuration.

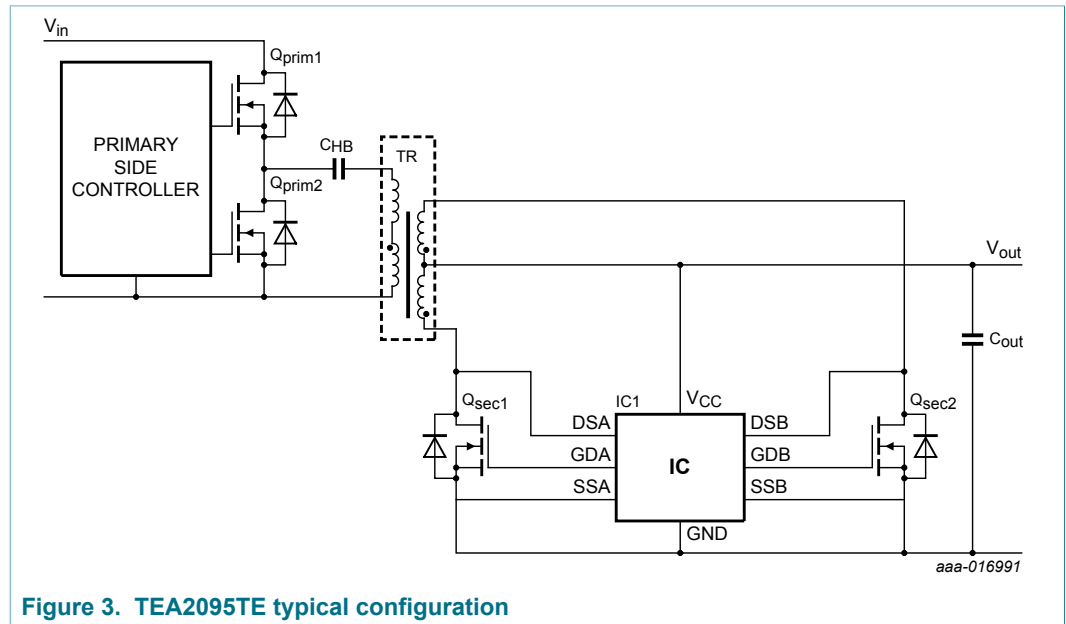

Figure 3. TEA2095TE typical configuration

8.2 Start-up and undervoltage lockout (V_{CC} pin)

When the voltage on the V_{CC} pin exceeds V_{start} , the IC leaves the UVLO state and activates the SR circuitry. When the voltage drops to below V_{stop} , the IC reenters the UVLO state. The SR MOSFET gate driver outputs are actively kept low. For proper operation, the V_{CC} pin must be decoupled with an extra capacitor (not only with C_{out}) between the V_{CC} pin and the GND pin. To reduce inductance effects because of high gate driver currents, the extra capacitor must be connected as close as possible to the IC.

8.3 Drain sense (DSA and DSB pins)

The drain sense pins are input pins capable of handling input voltages up to 120 V. At positive drain sense voltages, the gate driver is in off-mode with pulled-down gate driver pins (pins GDA or GDB). At negative drain sense voltages, the IC enables the SR through sensing the drain source differential voltage.

8.4 Synchronous rectification (SR; DSA, SSA, DSB, and SSB pins)

The IC senses the voltage difference between the drain sense (pins DSA and DSB) and the source sense (pins SSA and SSB) connections. The drain source differential voltage of the SR MOSFET is used to drive the gate of the SR MOSFET.

When this absolute voltage difference is higher than $V_{act(drv)}$, the corresponding gate driver output turns on the external SR MOSFET. When the external SR MOSFET is switched on, the absolute voltage difference between the drain and the source sense connections drops to below $V_{act(drv)}$. The regulation phase follows the turn-on phase.

In the regulation phase, the IC regulates the difference between the drain and the source sense inputs to an absolute level ($V_{reg(drv)}$). When the absolute difference is higher than $V_{reg(drv)}$, the gate driver output increases the gate voltage of the external SR MOSFET until the $V_{reg(drv)}$ level is reached. The SR MOSFET does not switch off at low currents. The IC operates without minimum on-time.

When the absolute difference is lower than $V_{deact(drv)}$, the gate driver output decreases the gate voltage of the external SR MOSFET. The voltage waveform on the gate of the SR MOSFET follows the waveform of the current through the SR MOSFET. When the current through the external SR MOSFET reaches zero, the SR MOSFET is quickly switched off.

After the SR MOSFET switch-off, the drain voltage increases. For a drain voltage above V_{swoff} , a low ohmic gate pull-down of $R_{pd(G)}$ keeps the gate of the SR MOSFET switched off.

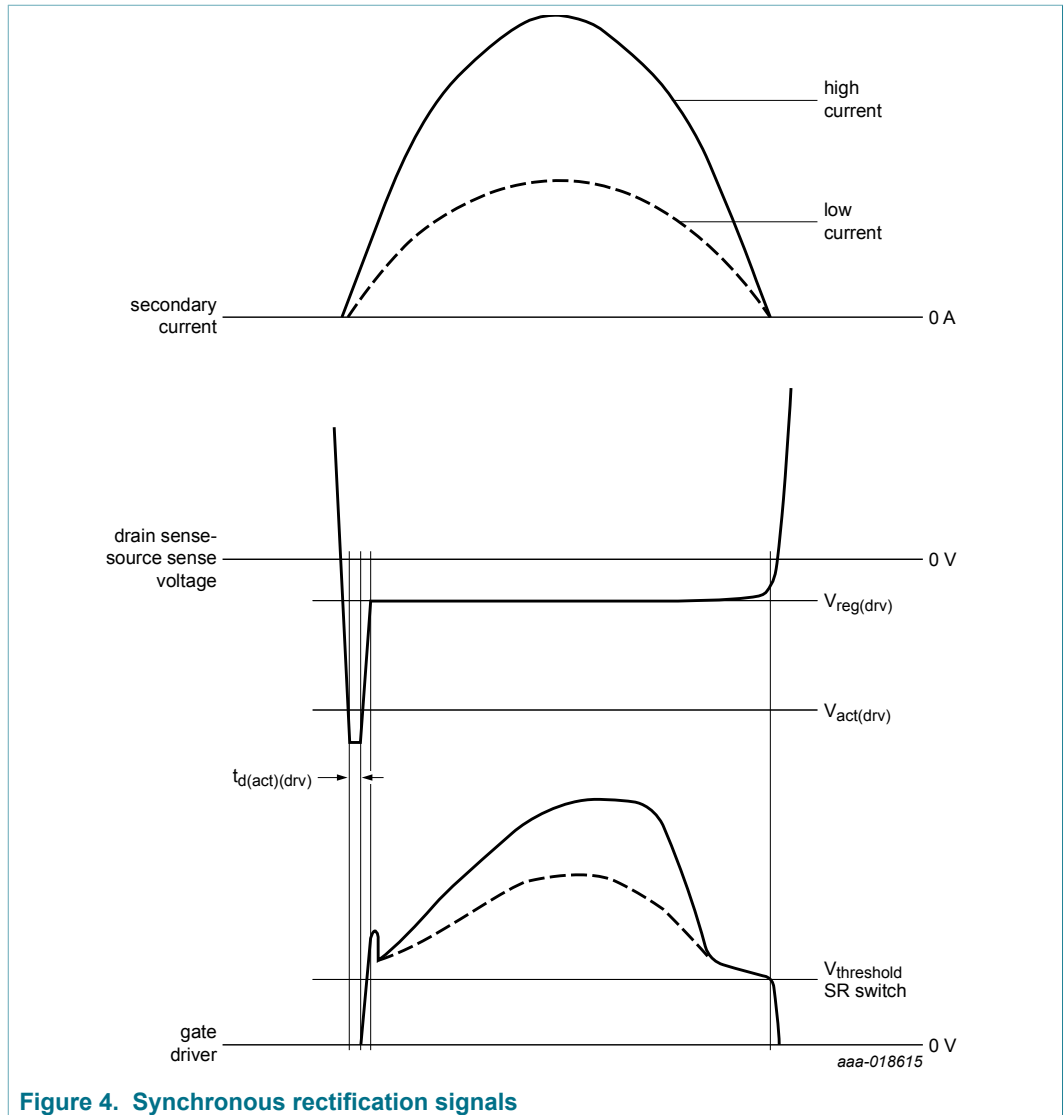

Figure 4. Synchronous rectification signals

8.5 Gate driver (GDA and GDB pins)

The gate driver circuit charges the gate of the external SR MOSFET during the rising part of the current. The driver circuit discharges the gate during the falling part of the current. The gate driver has a source capability of typically I_{source} and a sink capability of typically I_{sink} . The source and sink capability allow a fast turn-on and a fast turn-off of the external SR MOSFET.

The maximum driver output voltage is limited to $V_{G(max)}$. This high output voltage drives all MOSFET brands to the minimum on-state resistance.

In applications where the IC is supplied with 5 V, the maximum output voltage of the driver is limited to 5 V. Logic level SR MOSFETs can be used.

During start-up conditions ($V_{CC} < V_{start}$) and UVLO, the driver output voltage is actively pulled low.

8.6 Source sense connection (SSA and SSB pins)

The IC is equipped with additional source sense pins (SSA and SSB). These pins are used for the measurement of the SR MOSFET drain-to-source voltage. The source sense input must be connected as close as possible to the source pin of the external SR MOSFET. It minimizes errors caused by voltage difference on PCB tracks because of parasitic inductance in combination with large di/dt values.

8.7 Interlock function

The TEA2095TE incorporates an interlock function. The interlock function avoids the turn-on of both gate driver outputs at the same time.

After turn-off of one gate driver output, the IC waits typically 200 ns ($t_{d(\text{interlock})}$) before turning on the other gate driver output.

8.8 Discharge function

Disconnecting a power supply from the mains voltage should lead to zero output voltage and the power indicator turn-off. The TEA2095TE contains a discharge function that automatically discharges the output capacitor after a mains disconnect.

The detection of the mains disconnect happens by monitoring the activity of the synchronous rectification and applying a 1.4 s threshold for discriminating between no-load operation and power disconnect.

The discharge function creates a rapid discharging with a constant power dissipation of 0.4 W. [Figure 5](#) shows the secondary current, the drain sense voltage, the gate driver voltage, and the supply current.

The TEA2095TE enters the energy save mode 110 μ s after the last SR cycle. The supply current changes to a very low level of 90 μ A for low no-load power. After 1.4 seconds without SR activity, the TEA2095TE makes a transition to the discharge mode and draws a current of 0.4 W divided by the V_{CC} voltage.

For a V_{CC} voltage below UVLO, the discharge current reduces gradually to a level of 8 mA at 1 V V_{CC} voltage.

The discharge function remains active in the UVLO state. When the increasing V_{CC} voltage exceeds the start level, the discharge current switches off.

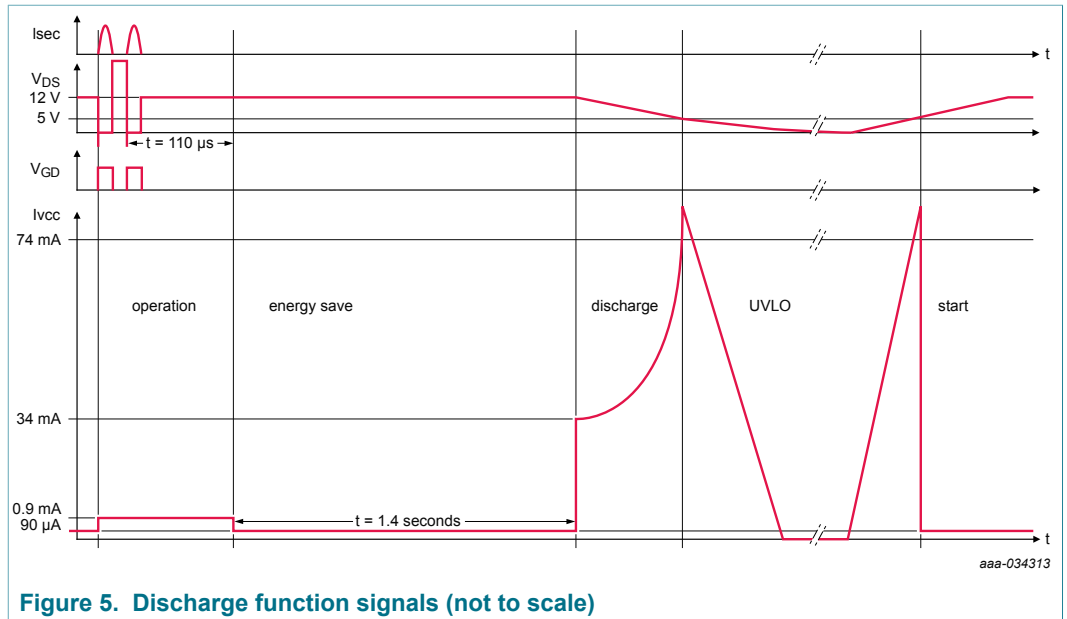

Figure 5. Discharge function signals (not to scale)

9 Limiting values

Table 4. Limiting values

In accordance with the Absolute Maximum Rating System (IEC 60134).

Symbol	Parameter	Conditions	Min	Max	Unit
Voltages					
V _{CC}	supply voltage		-0.4	+38	V
V _{sense(D)A}	drain sense voltage A	DC	-0.8	+120	V
V _{sense(D)B}	drain sense voltage B	DC	-0.8	+120	V
V _{sense(S)A}	source sense voltage A	DC	-0.4	+0.4	V
V _{sense(S)B}	source sense voltage B	DC	-0.4	+0.4	V
V _{GDA}	voltage on pin GDA	DC	^[1] -0.4	+12.0	V
V _{GDB}	voltage on pin GDB	DC	^[1] -0.4	+12.0	V
General					
f _{max}	maximum frequency	if not limited by P _{tot}	-	1	MHz
T _{stg}	storage temperature		-55	+150	°C
T _j	junction temperature		-40	+150	°C
Electrostatic discharge (ESD)					
V _{ESD}	electrostatic discharge voltage	human body model (HBM)	^[2] -	2000	V
		charged device model (CDM)	^[3] -	500	V

[1] Output pin; not to be voltage driven

[2] Human body model: Equivalent to discharging a 100 pF capacitor through a 1.5 kΩ series resistor.

[3] Charged device model: Equivalent to charging the IC and discharging each pin over a 1 Ω resistor.

10 Recommended operating conditions

Table 5. Recommended operating conditions

Symbol	Parameter	Conditions	Min	Max	Unit
V _{CC}	supply voltage		4.75	38	V
T _j	junction temperature		-40	+125	°C

11 Thermal characteristics

Table 6. Thermal characteristics

Symbol	Parameter	Conditions	Typ	Unit
R _{th(j-a)}	thermal resistance from junction to ambient	HSO8 package; PCB 4 layer; 4 vias; 0.4 mm; top/btm; 35 μm Cu; 60 mm x 125 mm; exposed die pad soldered to PCB	46	K/W
R _{th(j-c)}	thermal resistance from junction to case	HSO8 package	8	K/W

12 Characteristics

Table 7. Characteristics

$T_{amb} = 25\text{ }^{\circ}\text{C}$; $V_{CC} = 12\text{ V}$; $C_{GDA}/C_{GDB} = 10\text{ nF}$ (capacitors between GDA and GND and between GDB and GND). All voltages are measured with respect to ground (pin 2). Currents are positive when flowing into the IC, unless otherwise specified.

Symbol	Parameter	Conditions	Min	Typ	Max	Unit
Supply voltage management (pin V_{CC})						
V _{start}	start voltage		4.35	4.55	4.75	V
V _{stop}	stop voltage		4.0	4.2	4.4	V
I _{CC(oper)}	operating supply current	energy-save	80	90	110	μA
		normal operation (without gate charge)	0.7	0.9	1.05	mA
t _{act(es)}	energy save mode activation time		85	110	135	μs
Synchronous rectification sense input (pins DSA, SSA, DSB, and SSB)						
V _{act(drv)}	driver activation voltage	V _{sense(S)A} /V _{sense(S)B} = 0 V	-450	-400	-350	mV
V _{reg(drv)}	driver regulation voltage	V _{sense(S)A} /V _{sense(S)B} = 0 V	-33	-25	-20	mV
V _{swoff}	switch-off voltage	V _{sense(S)A} /V _{sense(S)B} = 0 V	60	150	200	mV
t _{d(act)(drv)}	driver activation delay time	V _{sense(S)A} /V _{sense(S)B} = 0 V; normal operation; time from step on V _{DSA} /V _{DSB} (2 V to -0.5 V) to rising of V _{GDA} /V _{GDB} at 10 % of end value	-	80	-	ns
t _{d(deact)(drv)}	driver deactivation delay time	V _{sense(S)A} /V _{sense(S)B} = 0 V; normal operation; time from step on V _{DSA} /V _{DSB} (-0.5 V to 2 V) to falling of V _{GDA} /V _{GDB} at 90 % of begin value	-	40	-	ns
t _d	delay time	interlock delay time	-	200	-	ns
Gate driver (pins GDA and GDB)						
I _{source}	source current	peak current at V _{DS} = -0.5 V; V _G = 0 V	-	-0.3	-	A
I _{sink}	sink current	regulation current at V _{DS} = 0 V; V _G = 5 V	-	1	-	A
		peak current at V _{DS} = 0.25 V; V _G = 5 V	-	2	-	A
R _{pd(G)}	gate pull-down resistance	V _{DS} = 12 V; I _G = 100 mA	2	2.5	3	Ω
V _{G(max)}	maximum gate voltage	V _{GDA} /V _{GDB} at V _{CC} = 5 V	4.98	4.99	5	V
		V _{GDA} /V _{GDB} at V _{CC} = 12 V	10.4	10.6	10.8	V
		V _{GDA} /V _{GDB} at V _{CC} = 38 V	10.7	11	11.2	V

Symbol	Parameter	Conditions	Min	Typ	Max	Unit
Discharge (pin V_{CC})						
t _d	delay time	discharge delay time	1.1	1.4	1.7	s
I _{dch}	discharge current	V _{VCC} = 19.5 V	21	24	27	mA
		V _{VCC} = 12 V	28	34	41	mA
		V _{VCC} = 5 V	63	74	81	mA
		V _{VCC} = 1 V	-	8	-	mA

13 Application information

A resonant switched mode power supply with the TEA2095TE consists of a primary side half-bridge, a transformer, a resonant capacitor, and an output stage. To obtain low conduction loss rectification, SR MOSFETs are used in the output stage. The TEA2095TE controls these SR MOSFETs.

The gate drive voltage for the SR switch is derived from the voltage difference between the corresponding drain sense and source sense pins.

Special attention must be paid to the connection of the drain sense and source sense pins. The voltages measured on these pins are used for gate drive voltage. Wrong measurement results in a less efficient gate drive because the gate voltage is either too low or too high. The connections to these pins must not interfere with the power wiring. The power wiring conducts currents with high di/dt values. It can easily cause measurement errors resulting from induced voltages due to parasitic inductances. The separate source-sense pins enable the direct sensing of the source voltage of the external MOSFETs. Using the current carrying power ground tracks is not allowed.

13.1 Application diagram resonant application

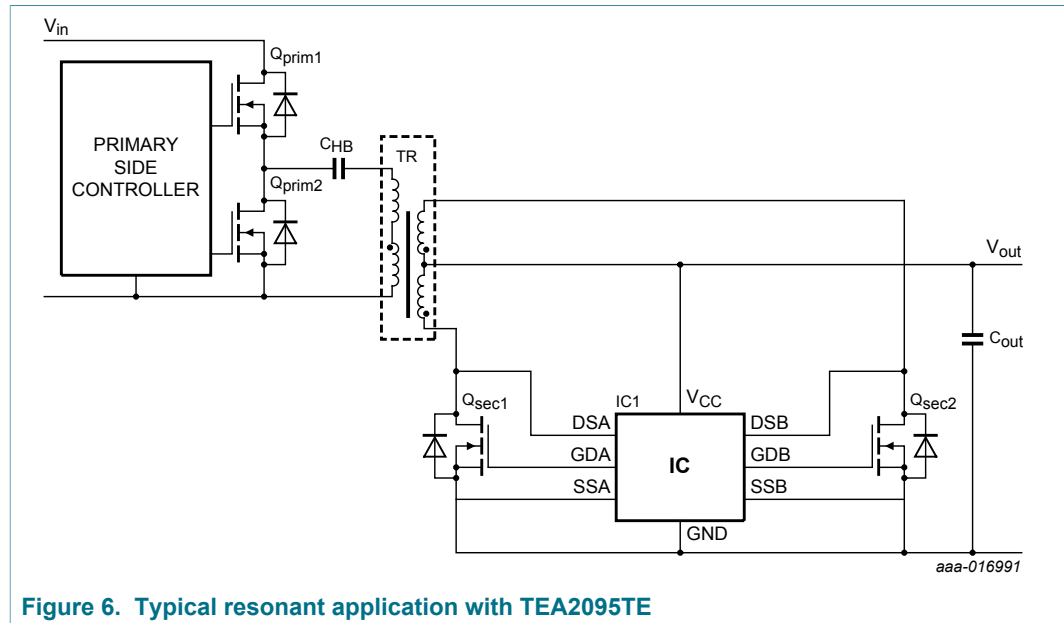
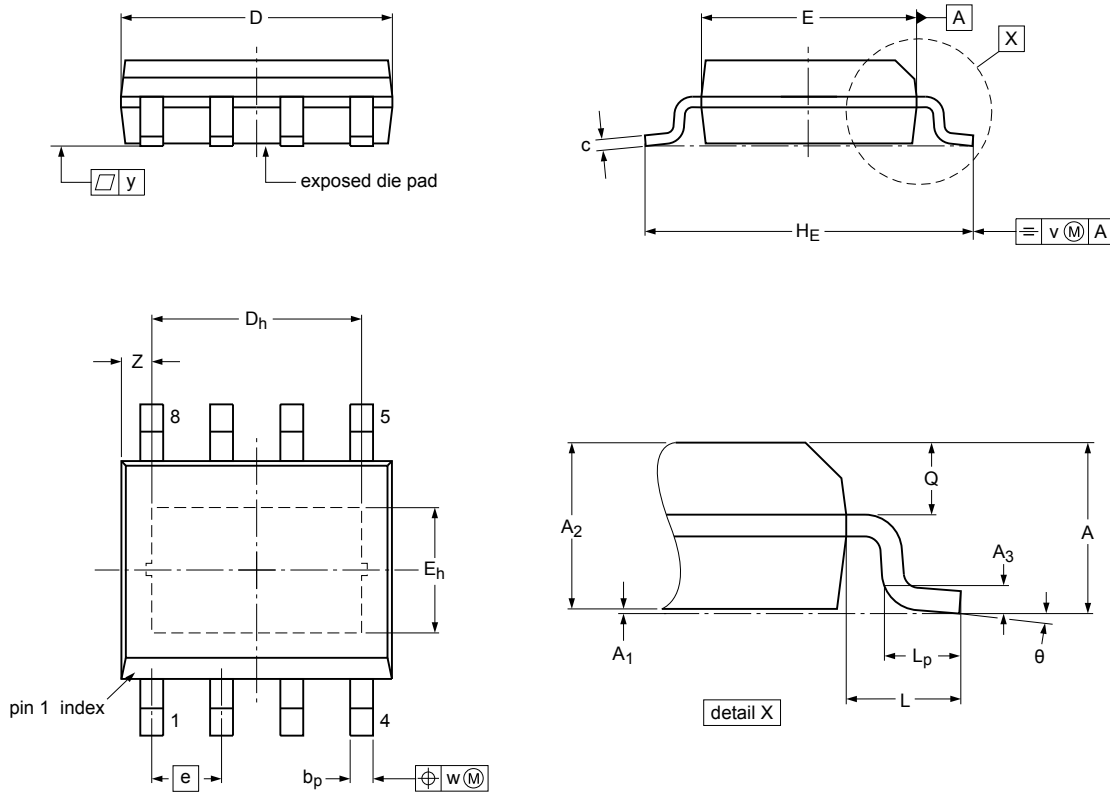

Figure 6. Typical resonant application with TEA2095TE

14 Package outline

HSO8: plastic thermal enhanced small outline package;
8 leads; body width 3.9 mm; exposed die pad

SOT786-3



Dimensions (mm are the original dimensions)

Unit	A	A ₁	A ₂	A ₃	b _p	c	D ⁽¹⁾	D _h	E ⁽¹⁾	E _h	e	H _E	L	L _p	Q	v	w	y	Z	θ
max	1.68	0.10	1.58		0.49	0.25	5.00	3.91	4.00	2.39		6.20		0.89	0.75				0.7	8°
nom	1.55	0.05	1.50	0.25	0.41	0.20	4.90	3.81	3.90	2.29	1.27	5.99	1.05	0.64	0.65	0.25	0.25	0.1	0.5	5°
min	1.43	0.00	1.43		0.35	0.19	4.80	2.95	3.80	2.19		5.84		0.41	0.55				0.3	0°

Note
1. Plastic or metal protrusions of 0.25 mm maximum per side are not included.

sot786-3_po

Outline version	References			European projection	Issue date
	IEC	JEDEC	JEITA		
SOT786-3					13-06-05 15-02-12

Figure 7. Package outline SOT786-3 (HSO8)

15 Abbreviations

Table 8. Abbreviations

Acronym	Description
CDM	charged device model
ESD	electrostatic discharge
HBM	human body model
MM	machine model
MOSFET	metal-oxide-semiconductor field-effect transistor
SOI	silicon-on-insulator
SR	synchronous rectification
UVLO	undervoltage lockout

16 Revision history

Table 9. Revision history

Document ID	Release date	Data sheet status	Change notice	Supersedes
TEA2095TE v.1.1	20200410	Product data sheet	-	TEA2095TE v.1
Modifications:	• Section 4 "Ordering information" has been updated.			
TEA2095TE v.1	20191025	Product data sheet	-	-

17 Legal information

17.1 Data sheet status

Document status ^{[1][2]}	Product status ^[3]	Definition
Objective [short] data sheet	Development	This document contains data from the objective specification for product development.
Preliminary [short] data sheet	Qualification	This document contains data from the preliminary specification.
Product [short] data sheet	Production	This document contains the product specification.

- [1] Please consult the most recently issued document before initiating or completing a design.
- [2] The term 'short data sheet' is explained in section "Definitions".
- [3] The product status of device(s) described in this document may have changed since this document was published and may differ in case of multiple devices. The latest product status information is available on the Internet at URL <http://www.nxp.com>.

17.2 Definitions

Draft — The document is a draft version only. The content is still under internal review and subject to formal approval, which may result in modifications or additions. NXP Semiconductors does not give any representations or warranties as to the accuracy or completeness of information included herein and shall have no liability for the consequences of use of such information.

Short data sheet — A short data sheet is an extract from a full data sheet with the same product type number(s) and title. A short data sheet is intended for quick reference only and should not be relied upon to contain detailed and full information. For detailed and full information see the relevant full data sheet, which is available on request via the local NXP Semiconductors sales office. In case of any inconsistency or conflict with the short data sheet, the full data sheet shall prevail.

Product specification — The information and data provided in a Product data sheet shall define the specification of the product as agreed between NXP Semiconductors and its customer, unless NXP Semiconductors and customer have explicitly agreed otherwise in writing. In no event however, shall an agreement be valid in which the NXP Semiconductors product is deemed to offer functions and qualities beyond those described in the Product data sheet.

17.3 Disclaimers

Limited warranty and liability — Information in this document is believed to be accurate and reliable. However, NXP Semiconductors does not give any representations or warranties, expressed or implied, as to the accuracy or completeness of such information and shall have no liability for the consequences of use of such information. NXP Semiconductors takes no responsibility for the content in this document if provided by an information source outside of NXP Semiconductors. In no event shall NXP Semiconductors be liable for any indirect, incidental, punitive, special or consequential damages (including - without limitation - lost profits, lost savings, business interruption, costs related to the removal or replacement of any products or rework charges) whether or not such damages are based on tort (including negligence), warranty, breach of contract or any other legal theory. Notwithstanding any damages that customer might incur for any reason whatsoever, NXP Semiconductors' aggregate and cumulative liability towards customer for the products described herein shall be limited in accordance with the Terms and conditions of commercial sale of NXP Semiconductors.

Right to make changes — NXP Semiconductors reserves the right to make changes to information published in this document, including without limitation specifications and product descriptions, at any time and without

notice. This document supersedes and replaces all information supplied prior to the publication hereof.

Suitability for use — NXP Semiconductors products are not designed, authorized or warranted to be suitable for use in life support, life-critical or safety-critical systems or equipment, nor in applications where failure or malfunction of an NXP Semiconductors product can reasonably be expected to result in personal injury, death or severe property or environmental damage. NXP Semiconductors and its suppliers accept no liability for inclusion and/or use of NXP Semiconductors products in such equipment or applications and therefore such inclusion and/or use is at the customer's own risk.

Applications — Applications that are described herein for any of these products are for illustrative purposes only. NXP Semiconductors makes no representation or warranty that such applications will be suitable for the specified use without further testing or modification. Customers are responsible for the design and operation of their applications and products using NXP Semiconductors products, and NXP Semiconductors accepts no liability for any assistance with applications or customer product design. It is customer's sole responsibility to determine whether the NXP Semiconductors product is suitable and fit for the customer's applications and products planned, as well as for the planned application and use of customer's third party customer(s). Customers should provide appropriate design and operating safeguards to minimize the risks associated with their applications and products. NXP Semiconductors does not accept any liability related to any default, damage, costs or problem which is based on any weakness or default in the customer's applications or products, or the application or use by customer's third party customer(s). Customer is responsible for doing all necessary testing for the customer's applications and products using NXP Semiconductors products in order to avoid a default of the applications and the products or of the application or use by customer's third party customer(s). NXP does not accept any liability in this respect.

Limiting values — Stress above one or more limiting values (as defined in the Absolute Maximum Ratings System of IEC 60134) will cause permanent damage to the device. Limiting values are stress ratings only and (proper) operation of the device at these or any other conditions above those given in the Recommended operating conditions section (if present) or the Characteristics sections of this document is not warranted. Constant or repeated exposure to limiting values will permanently and irreversibly affect the quality and reliability of the device.

Terms and conditions of commercial sale — NXP Semiconductors products are sold subject to the general terms and conditions of commercial sale, as published at <http://www.nxp.com/profile/terms>, unless otherwise agreed in a valid written individual agreement. In case an individual agreement is concluded only the terms and conditions of the respective agreement shall apply. NXP Semiconductors hereby expressly objects to applying the customer's general terms and conditions with regard to the purchase of NXP Semiconductors products by customer.

No offer to sell or license — Nothing in this document may be interpreted or construed as an offer to sell products that is open for acceptance or the grant, conveyance or implication of any license under any copyrights, patents or other industrial or intellectual property rights.

Export control — This document as well as the item(s) described herein may be subject to export control regulations. Export might require a prior authorization from competent authorities.

Non-automotive qualified products — Unless this data sheet expressly states that this specific NXP Semiconductors product is automotive qualified, the product is not suitable for automotive use. It is neither qualified nor tested in accordance with automotive testing or application requirements. NXP Semiconductors accepts no liability for inclusion and/or use of non-automotive qualified products in automotive equipment or applications. In the event that customer uses the product for design-in and use in automotive applications to automotive specifications and standards, customer (a) shall use the product without NXP Semiconductors' warranty of the product for such automotive applications, use and specifications, and (b) whenever customer uses the product for automotive applications beyond NXP Semiconductors' specifications such use shall be solely at customer's own risk, and (c) customer fully indemnifies NXP Semiconductors for any liability, damages or failed product claims resulting from customer design and use

of the product for automotive applications beyond NXP Semiconductors' standard warranty and NXP Semiconductors' product specifications.

Translations — A non-English (translated) version of a document is for reference only. The English version shall prevail in case of any discrepancy between the translated and English versions.

Security — While NXP Semiconductors has implemented advanced security features, all products may be subject to unidentified vulnerabilities. Customers are responsible for the design and operation of their applications and products to reduce the effect of these vulnerabilities on customer's applications and products, and NXP Semiconductors accepts no liability for any vulnerability that is discovered. Customers should implement appropriate design and operating safeguards to minimize the risks associated with their applications and products.

17.4 Trademarks

Notice: All referenced brands, product names, service names and trademarks are the property of their respective owners.

GreenChip — is a trademark of NXP B.V.

Contents

1	General description	1
2	Features and benefits	1
2.1	Efficiency features	1
2.2	Application features	1
2.3	Control features	1
3	Applications	2
4	Ordering information	2
5	Marking	2
6	Block diagram	3
7	Pinning information	4
7.1	Pinning	4
7.2	Pin description	4
8	Functional description	5
8.1	Introduction	5
8.2	Start-up and undervoltage lockout (VCC pin)	5
8.3	Drain sense (DSA and DSB pins)	5
8.4	Synchronous rectification (SR; DSA, SSA, DSB, and SSB pins)	6
8.5	Gate driver (GDA and GDB pins)	7
8.6	Source sense connection (SSA and SSB pins)	8
8.7	Interlock function	8
8.8	Discharge function	8
9	Limiting values	10
10	Recommended operating conditions	10
11	Thermal characteristics	10
12	Characteristics	11
13	Application information	13
13.1	Application diagram resonant application	13
14	Package outline	14
15	Abbreviations	15
16	Revision history	16
17	Legal information	17

Please be aware that important notices concerning this document and the product(s) described herein, have been included in section 'Legal information'.

© NXP B.V. 2020.

All rights reserved.

For more information, please visit: <http://www.nxp.com>

For sales office addresses, please send an email to: salesaddresses@nxp.com

Date of release: 10 April 2020
Document identifier: TEA2095TE