

ON Semiconductor

Is Now

onsemi™

To learn more about onsemi™, please visit our website at
www.onsemi.com

onsemi and **onsemi** and other names, marks, and brands are registered and/or common law trademarks of Semiconductor Components Industries, LLC dba "**onsemi**" or its affiliates and/or subsidiaries in the United States and/or other countries. **onsemi** owns the rights to a number of patents, trademarks, copyrights, trade secrets, and other intellectual property. A listing of **onsemi** product/patent coverage may be accessed at www.onsemi.com/site/pdf/Patent-Marking.pdf. **onsemi** reserves the right to make changes at any time to any products or information herein, without notice. The information herein is provided "as-is" and **onsemi** makes no warranty, representation or guarantee regarding the accuracy of the information, product features, availability, functionality, or suitability of its products for any particular purpose, nor does **onsemi** assume any liability arising out of the application or use of any product or circuit, and specifically disclaims any and all liability, including without limitation special, consequential or incidental damages. Buyer is responsible for its products and applications using **onsemi** products, including compliance with all laws, regulations and safety requirements or standards, regardless of any support or applications information provided by **onsemi**. "Typical" parameters which may be provided in **onsemi** data sheets and/or specifications can and do vary in different applications and actual performance may vary over time. All operating parameters, including "Typicals" must be validated for each customer application by customer's technical experts. **onsemi** does not convey any license under any of its intellectual property rights nor the rights of others. **onsemi** products are not designed, intended, or authorized for use as a critical component in life support systems or any FDA Class 3 medical devices or medical devices with a same or similar classification in a foreign jurisdiction or any devices intended for implantation in the human body. Should Buyer purchase or use **onsemi** products for any such unintended or unauthorized application, Buyer shall indemnify and hold **onsemi** and its officers, employees, subsidiaries, affiliates, and distributors harmless against all claims, costs, damages, and expenses, and reasonable attorney fees arising out of, directly or indirectly, any claim of personal injury or death associated with such unintended or unauthorized use, even if such claim alleges that **onsemi** was negligent regarding the design or manufacture of the part. **onsemi** is an Equal Opportunity/Affirmative Action Employer. This literature is subject to all applicable copyright laws and is not for resale in any manner. Other names and brands may be claimed as the property of others.

NLSX5012

2-Bit 100 Mb/s Configurable Dual-Supply Level Translator

The NLSX5012 is a 2-bit configurable dual-supply autosensing bidirectional level translator that does not require a direction control pin. The I/O V_{CC} - and I/O V_L -ports are designed to track two different power supply rails, V_{CC} and V_L respectively. Both the V_{CC} and the V_L supply rails are configurable from 0.9 V to 4.5 V. This allows a logic signal on the V_L side to be translated to either a higher or a lower logic signal voltage on the V_{CC} side, and vice-versa.

The NLSX5012 offers the feature that the values of the V_{CC} and V_L supplies are independent. Design flexibility is maximized because V_L can be set to a value either greater than or less than the V_{CC} supply. In contrast, the majority of competitive auto sense translators have a restriction that the value of the V_L supply must be equal to less than ($V_{CC} - 0.4$) V.

The NLSX5012 has high output current capability, which allows the translator to drive high capacitive loads such as most high frequency EMI filters. Another feature of the NLSX5012 is that each I/O V_{Ln} and I/O V_{CCn} channel can function as either an input or an output.

An Output Enable (EN) input is available to reduce the power consumption. The EN pin can be used to disable both I/O ports by putting them in 3-state which significantly reduces the supply current from both V_{CC} and V_L . The EN signal is referenced to the V_L supply.

Features

- Wide V_{CC} , V_L Operating Range: 0.9 V to 4.5 V
- V_L and V_{CC} are independent
 - V_L may be greater than, equal to, or less than V_{CC}
- High 100 pF Capacitive Drive Capability
- High-Speed with 140 Mb/s Guaranteed Data Rate for V_{CC} , $V_L > 1.8$ V
- Low Bit-to-Bit Skew
- Overvoltage Tolerant Enable and I/O Pins
- Non-preferential Power-Up Sequencing
- Power-Off Protection
- Small packaging: UDFN8, SO-8, Micro8
- These are Pb-Free Devices

Typical Applications

- Mobile Phones, PDAs, Other Portable Devices

Important Information

- ESD Protection for All Pins:
 - ♦ HBM (Human Body Model) > 8000 V



ON Semiconductor®

<http://onsemi.com>

MARKING DIAGRAMS



UDFN8
MU SUFFIX
CASE 517AJ

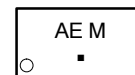

VA = Specific Device Code
M = Date Code
▪ = Pb-Free Package



SO-8
D SUFFIX
CASE 751

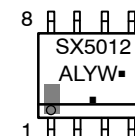

A = Assembly Location
L = Wafer Lot
Y = Year
W = Work Week
▪ = Pb-Free Package



Micro8
DM SUFFIX
CASE 846A

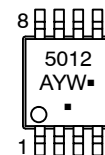

A = Assembly Location
Y = Year
W = Work Week
▪ = Pb-Free Package

ORDERING INFORMATION

Device	Package	Shipping†
NLSX5012MUTAG	UDFN8 (Pb-Free)	3000/Tape & Reel
NLSX5012DR2G	SO-8 (Pb-Free)	2500/Tape & Reel
NLSX5012DMR2G	Micro8 (Pb-Free)	4000/Tape & Reel

† For information on tape and reel specifications, including part orientation and tape sizes, please refer to our Tape and Reel Packaging Specification Brochure, BRD8011/D.

NLSX5012

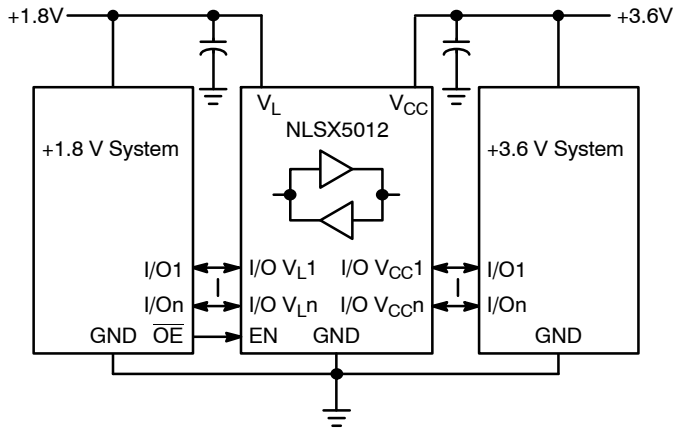

Figure 1. Typical Application Circuit

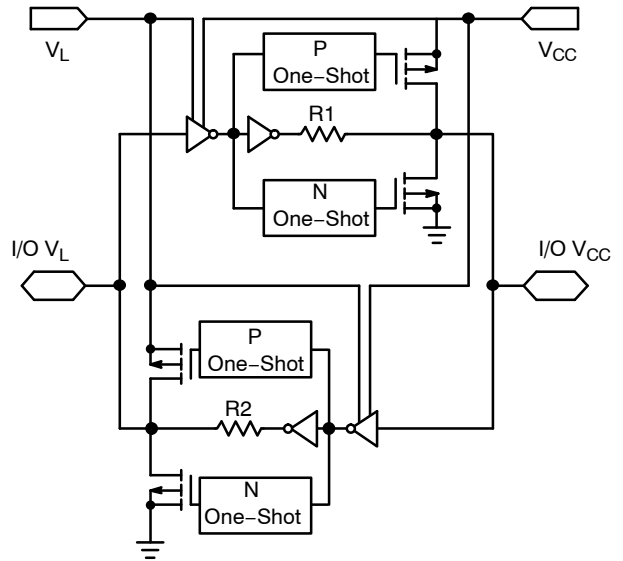

Figure 2. Simplified Functional Diagram (1 I/O Line)

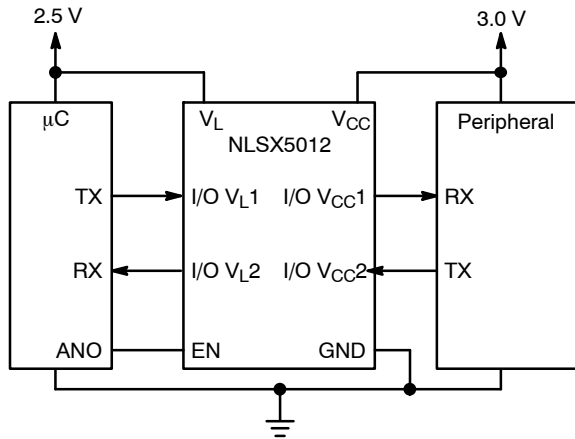

Figure 3. Application Example for $V_L < V_{CC}$

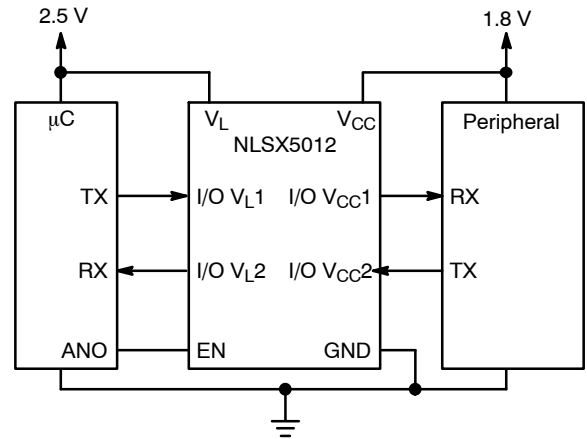

Figure 4. Application Example for $V_L > V_{CC}$

NLSX5012

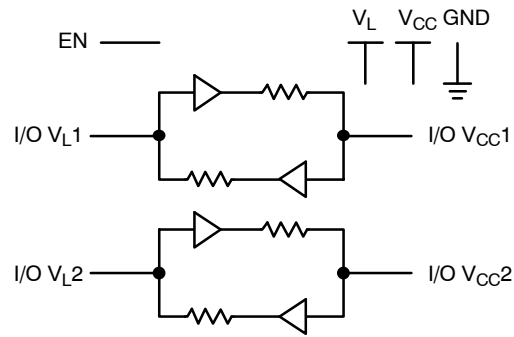

Figure 5. Logic Diagram

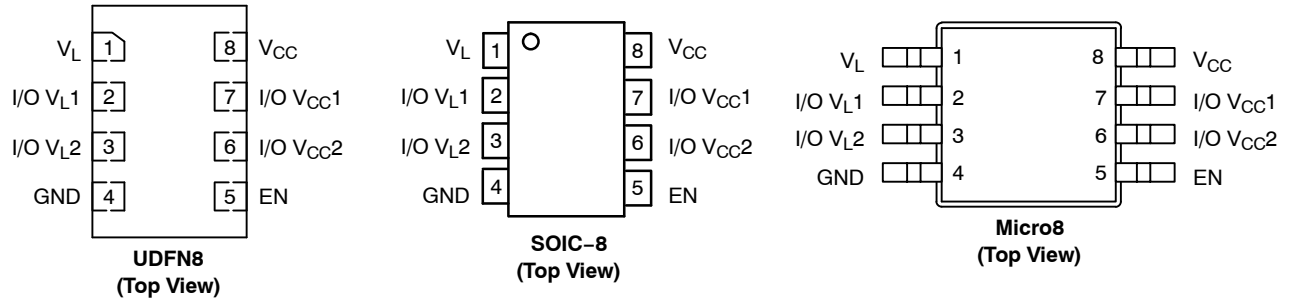

Figure 6. Pin Assignments

PIN ASSIGNMENT

Pins	Description
V _{CC}	V _{CC} Input Voltage
V _L	V _L Input Voltage
GND	Ground
EN	Output Enable
I/O V _{CCn}	I/O Port, Referenced to V _{CC}
I/O V _{Ln}	I/O Port, Referenced to V _L

FUNCTION TABLE

EN	Operating Mode
L	Hi-Z
H	I/O Buses Connected

NLSX5012

MAXIMUM RATINGS

Symbol	Parameter	Value	Condition	Unit
V_{CC}	High-side DC Supply Voltage	-0.5 to +5.5		V
V_L	Low-side DC Supply Voltage	-0.5 to +5.5		V
I/O V_{CC}	V_{CC} -Referenced DC Input/Output Voltage	-0.5 to +5.5		V
I/O V_L	V_L -Referenced DC Input/Output Voltage	-0.5 to +5.5		V
V_I	Enable Control Pin DC Input Voltage	-0.5 to +5.5		V
I_{IK}	DC Input Diode Current	-50	$V_I < \text{GND}$	mA
I_{OK}	DC Output Diode Current	-50	$V_O < \text{GND}$	mA
I_{CC}	DC Supply Current Through V_{CC}	± 100		mA
I_L	DC Supply Current Through V_L	± 100		mA
I_{GND}	DC Ground Current Through Ground Pin	± 100		mA
T_{STG}	Storage Temperature	-65 to +150		$^{\circ}\text{C}$

Stresses exceeding Maximum Ratings may damage the device. Maximum Ratings are stress ratings only. Functional operation above the Recommended Operating Conditions is not implied. Extended exposure to stresses above the Recommended Operating Conditions may affect device reliability.

RECOMMENDED OPERATING CONDITIONS

Symbol	Parameter	Min	Max	Unit
V_{CC}	High-side Positive DC Supply Voltage	0.9	4.5	V
V_L	Low-side Positive DC Supply Voltage	0.9	4.5	V
V_I	Enable Control Pin Voltage	GND	4.5	V
V_{IO}	Bus Input/Output Voltage	I/O V_{CC} I/O V_L	4.5 4.5	V
T_A	Operating Temperature Range	-55	+125	$^{\circ}\text{C}$
$\Delta t/\Delta V$	Input Transition Rise or Rate V_I, V_{IO} from 30% to 70% of V_{CC} ; $V_{CC} = 3.3 \text{ V} \pm 0.3 \text{ V}$	0	10	ns

NLSX5012

DC ELECTRICAL CHARACTERISTICS

Symbol	Parameter	Test Conditions (Note 1)	V _{CC} (V) (Note 2)	V _L (V) (Note 3)	-40°C to +85°C			-55°C to +125°C		Unit
					Min	Typ (Note 4)	Max	Min	Max	
V _{IHC}	I/O V _{CC} Input HIGH Voltage		0.9 – 4.5	0.9 – 4.5	2/3 * V _{CC}	–	–	2/3 * V _{CC}	–	V
V _{ILC}	I/O V _{CC} Input LOW Voltage		0.9 – 4.5	0.9 – 4.5	–	–	1/3 * V _{CC}	–	1/3 * V _{CC}	V
V _{IHL}	I/O V _L Input HIGH Voltage		0.9 – 4.5	0.9 – 4.5	2/3 * V _L	–	–	2/3 * V _L	–	V
V _{ILL}	I/O V _L Input LOW Voltage		0.9 – 4.5	0.9 – 4.5	–	–	1/3 * V _L	–	1/3 * V _L	V
V _{IH}	Control Pin Input HIGH Voltage	T _A = +25°C	0.9 – 4.5	0.9 – 4.5	2/3 * V _L	–	–	2/3 * V _L	–	V
V _{IL}	Control Pin Input LOW Voltage	T _A = +25°C	0.9 – 4.5	0.9 – 4.5	–	–	1/3 * V _L	–	1/3 * V _L	V
V _{OHC}	I/O V _{CC} Output HIGH Voltage	I/O V _{CC} source current = 20 μA	0.9 – 4.5	0.9 – 4.5	0.9 * V _{CC}	–	–	0.9 * V _{CC}	–	V
V _{OLC}	I/O V _{CC} Output LOW Voltage	I/O V _{CC} sink current = 20 μA	0.9 – 4.5	0.9 – 4.5	–	–	0.2	–	0.2	V
V _{OHL}	I/O V _L Output HIGH Voltage	I/O V _L source current = 20 μA	0.9 – 4.5	0.9 – 4.5	0.9 * V _L	–	–	0.9 * V _L	–	V
V _{OLL}	I/O V _L Output LOW Voltage	I/O V _L sink current = 20 μA	0.9 – 4.5	0.9 – 4.5	–	–	0.2	–	0.2	V
I _{QVCC}	V _{CC} Supply Current	EN = V _L , I _O = 0 A, (I/O V _{CC} = 0 V or V _{CC} , I/O V _L = float) or (I/O V _{CC} = float, I/O V _L = 0 V or V _L)	0.9 – 4.5	0.9 – 4.5	–	–	1	–	2.5	μA
I _{QVL}	V _L Supply Current		0.9 – 4.5	0.9 – 4.5	–	–	1	–	2.5	μA
I _{TS-VCC}	V _{CC} Tristate Output Mode Supply Current	T _A = +25°C, EN = 0 V (I/O V _{CC} = 0 V or V _{CC} , I/O V _L = float) or (I/O V _{CC} = float, I/O V _L = 0 V or V _L)	0.9 – 4.5	0.9 – 4.5	–	–	0.5	–	1.5	μA
I _{TS-VL}	V _L Tristate Output Mode Supply Current		0.9 – 4.5	0.9 – 4.5	–	–	0.5	–	1.5	μA
I _{OZ}	I/O Tristate Output Mode Leakage Current	T _A = +25°C, EN = 0V	0.9 – 4.5	0.9 – 4.5	–	–	±1	–	±1.5	μA
I _I	Control Pin Input Current	T _A = +25°C	0.9 – 4.5	0.9 – 4.5	–	–	±1	–	±1	μA
I _{OFF}	Power Off Leakage Current	I/O V _{CC} = 0 to 4.5V,	0	0	–	–	1	–	1.5	μA
		I/O V _L = 0 to 4.5 V	0.9 – 4.5	0	–	–	1	–	1.5	
			0	0.9 – 4.5	–	–	1	–	1.5	

1. Normal test conditions are V_I = 0 V, C_{I0VCC} ≤ 15 pF and C_{I0VL} ≤ 15 pF, unless otherwise specified.
2. V_{CC} is the supply voltage associated with the I/O V_{CC} port, and V_{CC} ranges from +0.9 V to 4.5 V under normal operating conditions.
3. V_L is the supply voltage associated with the I/O V_L port, and V_L ranges from +0.9 V to 4.5 V under normal operating conditions.
4. Typical values are for V_{CC} = +2.8 V, V_L = +1.8 V and T_A = +25°C. All units are production tested at T_A = +25°C. Limits over the operating temperature range are guaranteed by design.

NLSX5012

TIMING CHARACTERISTICS

Symbol	Parameter	Test Conditions (Note 5)	V _{CC} (V) (Note 6)	V _L (V) (Note 7)	-55°C to +125°C			Unit
					Min	Typ (Note 8)	Max	
t _{R-VCC}	I/O V _{CC} Rise Time	C _{I OVCC} = 15 pF	0.9 – 4.5	0.9 – 4.5	–	–	8.5	nS
			1.8 – 4.5	1.8 – 4.5	–	–	3.5	
t _{F-VCC}	I/O V _{CC} Fall Time	C _{I OVCC} = 15 pF	0.9 – 4.5	0.9 – 4.5	–	–	8.5	nS
			1.8 – 4.5	1.8 – 4.5	–	–	3.5	
t _{R-VL}	I/O V _L Rise Time	C _{I OVL} = 15 pF	0.9 – 4.5	0.9 – 4.5	–	–	8.5	nS
			1.8 – 4.5	1.8 – 4.5	–	–	3.5	
t _{F-VL}	I/O V _L Fall Time	C _{I OVL} = 15 pF	0.9 – 4.5	0.9 – 4.5	–	–	8.5	nS
			1.8 – 4.5	1.8 – 4.5	–	–	3.5	
Z _{OVCC}	I/O V _{CC} One-Shot Output Impedance	(Note 9)	0.9	0.9 – 4.5	–	37	–	Ω
			1.8		–	20	–	
			4.5		–	6.0	–	
Z _{OVL}	I/O V _L One-Shot Output Impedance	(Note 9)	0.9	0.9 – 4.5	–	37	–	Ω
			1.8		–	20	–	
			4.5		–	6.0	–	
t _{PD_VL-VCC}	Propagation Delay (Driving I/O V _{CC})	C _{I OVCC} = 15 pF	0.9 – 4.5	0.9 – 4.5	–	–	35	nS
			1.8 – 4.5	1.8 – 4.5	–	–	10	
		C _{I OVCC} = 30 pF	0.9 – 4.5	0.9 – 4.5	–	–	35	
			1.8 – 4.5	1.8 – 4.5	–	–	10	
		C _{I OVCC} = 50 pF	1.0 – 4.5	1.0 – 4.5	–	–	37	
			1.8 – 4.5	1.8 – 4.5	–	–	11	
C _{I OVCC} = 100 pF	1.2 – 4.5	1.2 – 4.5	–	–	40			
	1.8 – 4.5	1.8 – 4.5	–	–	13			
t _{PD_VCC-VL}	Propagation Delay (Driving I/O V _L)	C _{I OVL} = 15 pF	0.9 – 4.5	0.9 – 4.5	–	–	35	nS
			1.8 – 4.5	1.8 – 4.5	–	–	10	
		C _{I OVL} = 30 pF	0.9 – 4.5	0.9 – 4.5	–	–	35	
			1.8 – 4.5	1.8 – 4.5	–	–	10	
		C _{I OVL} = 50 pF	1.0 – 4.5	1.0 – 4.5	–	–	37	
			1.8 – 4.5	1.8 – 4.5	–	–	11	
C _{I OVL} = 100 pF	1.2 – 4.5	1.2 – 4.5	–	–	40			
	1.8 – 4.5	1.8 – 4.5	–	–	13			
t _{SK}	Channel-to-Channel Skew	C _{I OVCC} = 15 pF, C _{I OVL} = 15 pF (Note 9)	0.9 – 4.5	0.9 – 4.5	–	–	0.15	nS
I _{IN_PEAK}	Input Driver Maximum Peak Current	EN = V _L ; I/O_V _{CC} = 1 MHz Square Wave, Amplitude = V _{CC} , or I/O_V _L = 1 MHz Square Wave, Amplitude = V _L (Note 9)	0.9 – 4.5	0.9 – 4.5	–	–	5.0	mA

5. Normal test conditions are V_I = 0 V, C_{I OVCC} ≤ 15 pF and C_{I OVL} ≤ 15 pF, unless otherwise specified.

6. V_{CC} is the supply voltage associated with the I/O V_{CC} port, and V_{CC} ranges from +0.9 V to 4.5 V under normal operating conditions.

7. V_L is the supply voltage associated with the I/O V_L port, and V_L ranges from +0.9 V to 4.5 V under normal operating conditions.

8. Typical values are for V_{CC} = +2.8 V, V_L = +1.8 V and T_A = +25°C. All units are production tested at T_A = +25°C. Limits over the operating temperature range are guaranteed by design.

9. Guaranteed by design.

NLSX5012

TIMING CHARACTERISTICS (continued)

Symbol	Parameter	Test Conditions (Note 10)	V _{CC} (V) (Note 11)	V _L (V) (Note 12)	-55°C to +125°C			Unit	
					Min	Typ (Note 13)	Max		
t _{EN-VCC}	I/O_V _{CC} Output Enable Time	t _{PZH}	C _{I_OV_{CC}} = 15 pF, I/O_V _L = V _L	0.9 – 4.5	0.9 – 4.5	–	–	160	nS
		t _{PZL}	C _{I_OV_{CC}} = 15 pF, I/O_V _L = 0 V	0.9 – 4.5	0.9 – 4.5	–	–	130	
t _{EN-VL}	I/O_V _L Output Enable Time	t _{PZH}	C _{I_OV_L} = 15 pF, I/O_V _{CC} = V _{CC}	0.9 – 4.5	0.9 – 4.5	–	–	160	nS
		t _{PZL}	C _{I_OV_L} = 15 pF, I/O_V _{CC} = 0 V	0.9 – 4.5	0.9 – 4.5	–	–	130	
t _{DIS-VCC}	I/O_V _{CC} Output Disable Time	t _{PHZ}	C _{I_OV_{CC}} = 15 pF, I/O_V _L = V _L	0.9 – 4.5	0.9 – 4.5	–	–	210	nS
		t _{PLZ}	C _{I_OV_{CC}} = 15 pF, I/O_V _L = 0 V	0.9 – 4.5	0.9 – 4.5	–	–	175	
t _{DIS-VL}	I/O_V _L Output Disable Time	t _{PHZ}	C _{I_OV_L} = 15 pF, I/O_V _{CC} = V _{CC}	0.9 – 4.5	0.9 – 4.5	–	–	210	nS
		t _{PLZ}	C _{I_OV_L} = 15 pF, I/O_V _{CC} = 0 V	0.9 – 4.5	0.9 – 4.5	–	–	175	
MDR	Maximum Data Rate	C _{I_O} = 15 pF	0.9 – 4.5	0.9 – 4.5	50	–	–	mbps	
			1.8 – 4.5	1.8 – 4.5	140	–	–		
		C _{I_O} = 30 pF	0.9 – 4.5	0.9 – 4.5	40	–	–		
			1.8 – 4.5	1.8 – 4.5	120	–	–		
		C _{I_O} = 50 pF	1.0 – 4.5	1.0 – 4.5	30	–	–		
			1.8 – 4.5	1.8 – 4.5	100	–	–		
C _{I_O} = 100 pF	1.2 – 4.5	1.2 – 4.5	20	–	–				
	1.8 – 4.5	1.8 – 4.5	60	–	–				

10. Normal test conditions are V_I = 0 V, C_{I_OV_{CC}} ≤ 15 pF and C_{I_OV_L} ≤ 15 pF, unless otherwise specified.

11. V_{CC} is the supply voltage associated with the I/O V_{CC} port, and V_{CC} ranges from +0.9 V to 4.5 V under normal operating conditions.

12. V_L is the supply voltage associated with the I/O V_L port, and V_L ranges from +0.9 V to 4.5 V under normal operating conditions.

13. Typical values are for V_{CC} = +2.8 V, V_L = +1.8 V and T_A = +25°C. All units are production tested at T_A = +25°C. Limits over the operating temperature range are guaranteed by design.

NLSX5012

DYNAMIC POWER CONSUMPTION ($T_A = +25^\circ\text{C}$)

Symbol	Parameter	Test Conditions	V _{CC} (V) (Note 14)	V _L (V) (Note 15)	Typ (Note 16)	Unit
C _{PD_VL}	V _L = Input port, V _{CC} = Output Port	C _{Load} = 0, f = 1 MHz, EN = V _L (outputs enabled)	0.9	4.5	39	pF
			1.5	1.8	20	
			1.8	1.5	17	
			1.8	1.8	14	
			1.8	2.8	13	
			2.5	2.5	14	
			2.8	1.8	13	
			4.5	0.9	19	
	V _{CC} = Input port, V _L = Output Port	C _{Load} = 0, f = 1 MHz, EN = V _L (outputs enabled)	0.9	4.5	37	pF
			1.5	1.8	30	
			1.8	1.5	29	
			1.8	1.8	29	
			1.8	2.8	29	
			2.5	2.5	30	
2.8			1.8	29		
4.5			0.9	19		
C _{PD_VCC}	V _L = Input port, V _{CC} = Output Port	C _{Load} = 0, f = 1 MHz, EN = V _L (outputs enabled)	0.9	4.5	29	pF
			1.5	1.8	29	
			1.8	1.5	29	
			1.8	1.8	29	
			1.8	2.8	29	
			2.5	2.5	30	
			2.8	1.8	29	
			4.5	0.9	35	
	V _{CC} = Input port, V _L = Output Port	C _{Load} = 0, f = 1 MHz, EN = V _L (outputs enabled)	0.9	4.5	21	pF
			1.5	1.8	18	
			1.8	1.5	18	
			1.8	1.8	14	
			1.8	2.8	13	
			2.5	2.5	14	
2.8			1.8	13		
4.5			0.9	30		

14. V_{CC} is the supply voltage associated with the I/O V_{CC} port, and V_{CC} ranges from +0.9 V to 4.5 V under normal operating conditions.

15. V_L is the supply voltage associated with the I/O V_L port, and V_L ranges from +0.9 V to 4.5 V under normal operating conditions.

16. Typical values are at T_A = +25°C.

17. C_{PD_VL} and C_{PD_VCC} are defined as the value of the IC's equivalent capacitance from which the operating current can be calculated for the V_L and V_{CC} power supplies, respectively. I_{CC} = I_{CC} (dynamic) + I_{CC} (static) ≈ I_{CC}(operating) ≈ C_{PD} × V_{CC} × f_{IN} × N_{SW} where I_{CC} = I_{CC_VCC} + I_{CC_VL} and N_{SW} = total number of outputs switching.

NLSX5012

STATIC POWER CONSUMPTION ($T_A = +25^\circ\text{C}$)

Symbol	Parameter	Test Conditions	V _{CC} (V) (Note 18)	V _L (V) (Note 19)	Typ (Note 20)	Unit
C _{PD_VL}	V _L = Input port, V _{CC} = Output Port	C _{Load} = 0, f = 1 MHz, EN = GND (outputs disabled)	0.9	4.5	0.01	pF
			1.5	1.8	0.01	
			1.8	1.5	0.01	
			1.8	1.8	0.01	
			1.8	2.8	0.01	
			2.5	2.5	0.01	
			2.8	1.8	0.01	
	4.5	0.9	0.01			
	V _{CC} = Input port, V _L = Output Port	C _{Load} = 0, f = 1 MHz, EN = GND (outputs disabled)	0.9	4.5	0.01	pF
			1.5	1.8	0.01	
			1.8	1.5	0.01	
			1.8	1.8	0.01	
			1.8	2.8	0.01	
			2.5	2.5	0.01	
2.8			1.8	0.01		
4.5	0.9	0.01				
C _{PD_VCC}	V _L = Input port, V _{CC} = Output Port	C _{Load} = 0, f = 1 MHz, EN = GND (outputs disabled)	0.9	4.5	0.01	pF
			1.5	1.8	0.01	
			1.8	1.5	0.01	
			1.8	1.8	0.01	
			1.8	2.8	0.01	
			2.5	2.5	0.01	
			2.8	1.8	0.01	
	4.5	0.9	0.01			
	V _{CC} = Input port, V _L = Output Port	C _{Load} = 0, f = 1 MHz, EN = GND (outputs disabled)	0.9	4.5	0.01	pF
			1.5	1.8	0.01	
			1.8	1.5	0.01	
			1.8	1.8	0.01	
			1.8	2.8	0.01	
			2.5	2.5	0.01	
2.8			1.8	0.01		
4.5	0.9	0.01				

18. V_{CC} is the supply voltage associated with the I/O V_{CC} port, and V_{CC} ranges from +0.9 V to 4.5 V under normal operating conditions.

19. V_L is the supply voltage associated with the I/O V_L port, and V_L ranges from +0.9 V to 4.5 V under normal operating conditions.

20. Typical values are at T_A = +25°C

NLSX5012

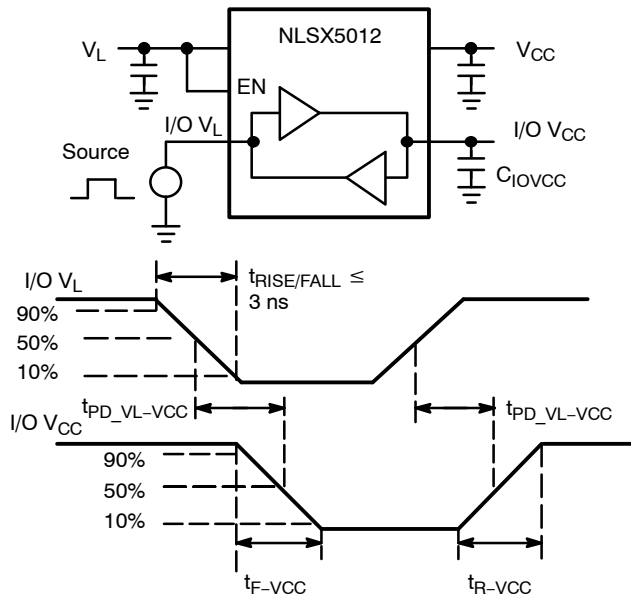

Figure 7. Driving I/O V_L Test Circuit and Timing

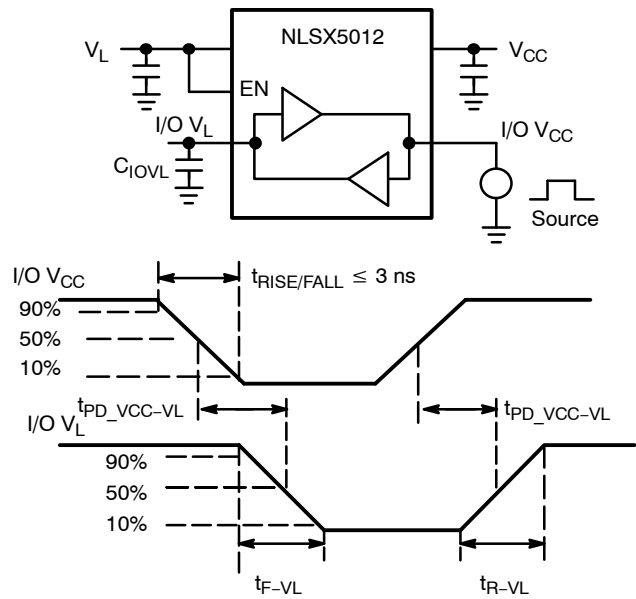
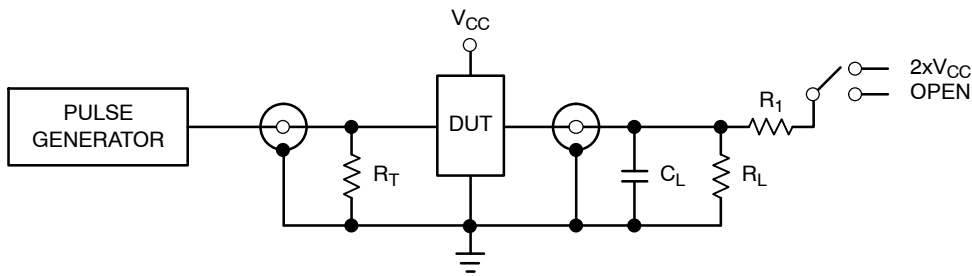

Figure 8. Driving I/O V_{CC} Test Circuit and Timing



Test	Switch
t_{PZH} , t_{PHZ}	Open
t_{PZL} , t_{PLZ}	$2 \times V_{CC}$

$C_L = 15 \text{ pF}$ or equivalent (Includes jig and probe capacitance)
 $R_L = R_1 = 50 \text{ k}\Omega$ or equivalent
 $R_T = Z_{OUT}$ of pulse generator (typically 50Ω)

Figure 9. Test Circuit for Enable/Disable Time Measurement

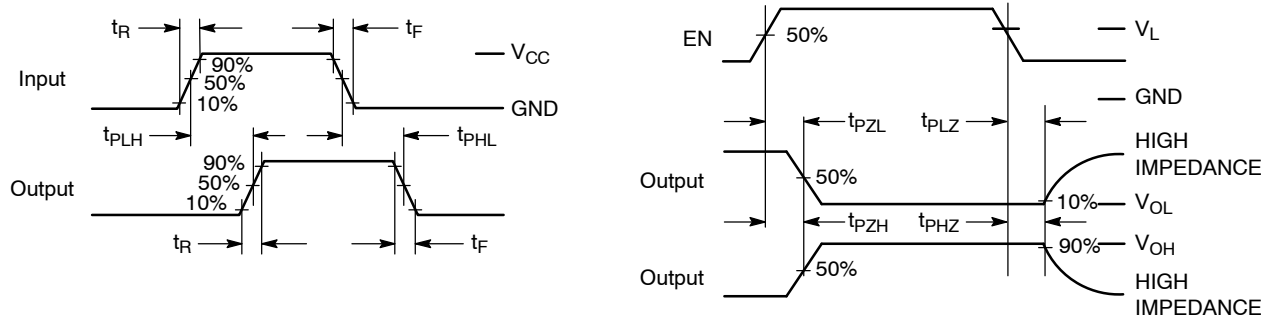

Figure 10. Timing Definitions for Propagation Delays and Enable/Disable Measurement

IMPORTANT APPLICATIONS INFORMATION

Level Translator Architecture

The NLSX5012 auto-sense translator provides bi-directional logic voltage level shifting to transfer data in multiple supply voltage systems. These level translators have two supply voltages, V_L and V_{CC} , which set the logic levels on the input and output sides of the translator. When used to transfer data from the I/O V_L to the I/O V_{CC} ports, input signals referenced to the V_L supply are translated to output signals with a logic level matched to V_{CC} . In a similar manner, the I/O V_{CC} to I/O V_L translation shifts input signals with a logic level compatible to V_{CC} to an output signal matched to V_L .

The NLSX5012 translator consists of bi-directional channels that independently determine the direction of the data flow without requiring a directional pin. One-shot circuits are used to detect the rising or falling input signals. In addition, the one-shots decrease the rise and fall times of the output signal for high-to-low and low-to-high transitions.

Input Driver Requirements

Auto-sense translators such as the NLSX5012 have a wide bandwidth, but a relatively small DC output current rating. The high bandwidth of the bi-directional I/O circuit is used to quickly transform from an input to an output driver and vice versa. The I/O ports have a modest DC current output specification so that the output driver can be over driven when data is sent in the opposite direction. For proper operation, the input driver to the auto-sense translator should be capable of driving 2 mA of peak output current. The bi-directional configuration of the translator results in both input stages being active for a very short time period. Although the peak current from the input signal circuit is relatively large, the average current is small and consistent with a standard CMOS input stage.

Enable Input (EN)

The NLSX5012 translator has an Enable pin (EN) that provides tri-state operation at the I/O pins. Driving the Enable pin to a low logic level minimizes the power consumption of the device and drives the I/O V_{CC} and I/O

V_L pins to a high impedance state. Normal translation operation occurs when the EN pin is equal to a logic high signal. The EN pin is referenced to the V_L supply and has Over-Voltage Tolerant (OVT) protection.

Uni-Directional versus Bi-Directional Translation

The NLSX5012 translator can function as a non-inverting uni-directional translator. One advantage of using the translator as a uni-directional device is that each I/O pin can be configured as either an input or output. The configurable input or output feature is especially useful in applications such as SPI that use multiple uni-directional I/O lines to send data to and from a device. The flexible I/O port of the auto sense translator simplifies the trace connections on the PCB.

Power Supply Guidelines

The values of the V_L and V_{CC} supplies can be set to anywhere between 0.9 and 4.5 V. Design flexibility is maximized because V_L may be either greater than or less than the V_{CC} supply. In contrast, the majority of the competitive auto sense translators has a restriction that the value of the V_L supply must be equal to less than ($V_{CC} - 0.4$) V.

The sequencing of the power supplies will not damage the device during power-up operation. In addition, the I/O V_{CC} and I/O V_L pins are in the high impedance state if either supply voltage is equal to 0 V. For optimal performance, 0.01 to 0.1 μ F decoupling capacitors should be used on the V_L and V_{CC} power supply pins. Ceramic capacitors are a good design choice to filter and bypass any noise signals on the voltage lines to the ground plane of the PCB. The noise immunity will be maximized by placing the capacitors as close as possible to the supply and ground pins, along with minimizing the PCB connection traces.

The NLSX5012 translators have a power down feature that provides design flexibility. The output ports are disabled when either power supply is off (V_L or $V_{CC} = 0$ V). This feature causes all of the I/O pins to be in the power saving high impedance state.

MECHANICAL CASE OUTLINE

PACKAGE DIMENSIONS

ON Semiconductor®



SCALE 4:1

UDFN8 1.8x1.2, 0.4P
CASE 517AJ-01
ISSUE O

DATE 08 NOV 2006

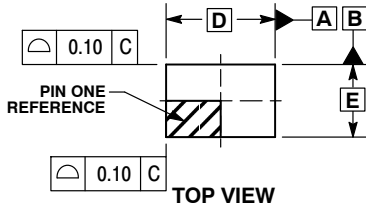

TOP VIEW

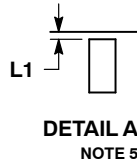

DETAIL A
NOTE 5

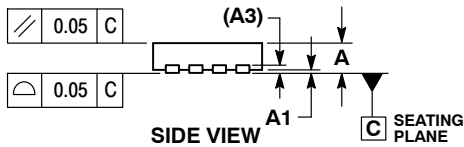

SIDE VIEW

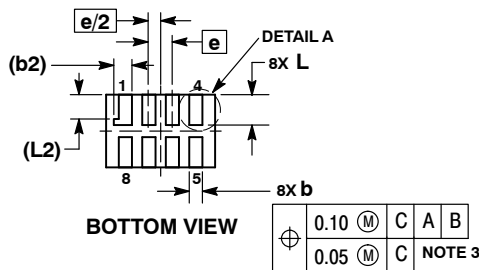

BOTTOM VIEW

⊕	0.10 (M)	C	A	B
	0.05 (M)	C		

NOTE 3

NOTES:

1. DIMENSIONING AND TOLERANCING PER ASME Y14.5M, 1994.
2. CONTROLLING DIMENSION: MILLIMETERS.
3. DIMENSION b APPLIES TO PLATED TERMINAL AND IS MEASURED BETWEEN 0.15 AND 0.30 mm FROM TERMINAL TIP.
4. MOLD FLASH ALLOWED ON TERMINALS ALONG EDGE OF PACKAGE. FLASH MAY NOT EXCEED 0.03 ONTO BOTTOM SURFACE OF TERMINALS.
5. DETAIL A SHOWS OPTIONAL CONSTRUCTION FOR TERMINALS.

DIM	MILLIMETERS	
	MIN	MAX
A	0.45	0.55
A1	0.00	0.05
A3	0.127	REF
b	0.15	0.25
b2	0.30	REF
D	1.80	BSC
E	1.20	BSC
e	0.40	BSC
L	0.45	0.55
L1	0.00	0.03
L2	0.40	REF

GENERIC MARKING DIAGRAM*

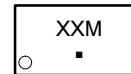

- XX = Specific Device Code
- M = Date Code
- = Pb-Free Package

*This information is generic. Please refer to device data sheet for actual part marking. Pb-Free indicator, "G" or microdot "▪", may or may not be present.

MOUNTING FOOTPRINT
SOLDERMASK DEFINED

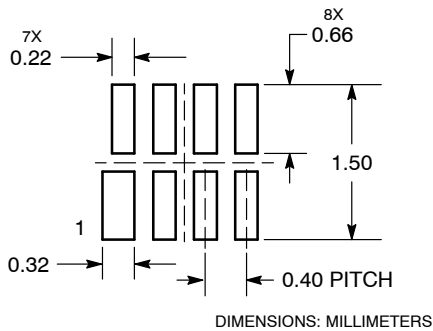

DIMENSIONS: MILLIMETERS

DOCUMENT NUMBER:	98AON23417D	Electronic versions are uncontrolled except when accessed directly from the Document Repository. Printed versions are uncontrolled except when stamped "CONTROLLED COPY" in red.
DESCRIPTION:	UDFN8 1.8X1.2, 0.4P	PAGE 1 OF 1

ON Semiconductor and ON are trademarks of Semiconductor Components Industries, LLC dba ON Semiconductor or its subsidiaries in the United States and/or other countries. ON Semiconductor reserves the right to make changes without further notice to any products herein. ON Semiconductor makes no warranty, representation or guarantee regarding the suitability of its products for any particular purpose, nor does ON Semiconductor assume any liability arising out of the application or use of any product or circuit, and specifically disclaims any and all liability, including without limitation special, consequential or incidental damages. ON Semiconductor does not convey any license under its patent rights nor the rights of others.

MECHANICAL CASE OUTLINE PACKAGE DIMENSIONS

ON Semiconductor®



SCALE 1:1

SOIC-8 NB
CASE 751-07
ISSUE AK

DATE 16 FEB 2011



- NOTES:
1. DIMENSIONING AND TOLERANCING PER ANSI Y14.5M, 1982.
 2. CONTROLLING DIMENSION: MILLIMETER.
 3. DIMENSION A AND B DO NOT INCLUDE MOLD PROTRUSION.
 4. MAXIMUM MOLD PROTRUSION 0.15 (0.006) PER SIDE.
 5. DIMENSION D DOES NOT INCLUDE DAMBAR PROTRUSION. ALLOWABLE DAMBAR PROTRUSION SHALL BE 0.127 (0.005) TOTAL IN EXCESS OF THE D DIMENSION AT MAXIMUM MATERIAL CONDITION.
 6. 751-01 THRU 751-06 ARE OBSOLETE. NEW STANDARD IS 751-07.

DIM	MILLIMETERS		INCHES	
	MIN	MAX	MIN	MAX
A	4.80	5.00	0.189	0.197
B	3.80	4.00	0.150	0.157
C	1.35	1.75	0.053	0.069
D	0.33	0.51	0.013	0.020
G	1.27 BSC		0.050 BSC	
H	0.10	0.25	0.004	0.010
J	0.19	0.25	0.007	0.010
K	0.40	1.27	0.016	0.050
M	0°	8°	0°	8°
N	0.25	0.50	0.010	0.020
S	5.80	6.20	0.228	0.244

SOLDERING FOOTPRINT*



*For additional information on our Pb-Free strategy and soldering details, please download the ON Semiconductor Soldering and Mounting Techniques Reference Manual, SOLDERRM/D.

GENERIC MARKING DIAGRAM*



XXXXXX = Specific Device Code
A = Assembly Location
L = Wafer Lot
Y = Year
W = Work Week
▪ = Pb-Free Package

XXXXXX = Specific Device Code
A = Assembly Location
Y = Year
WW = Work Week
▪ = Pb-Free Package

*This information is generic. Please refer to device data sheet for actual part marking. Pb-Free indicator, "G" or microdot "▪", may or may not be present. Some products may not follow the Generic Marking.

STYLES ON PAGE 2

DOCUMENT NUMBER:	98ASB42564B	Electronic versions are uncontrolled except when accessed directly from the Document Repository. Printed versions are uncontrolled except when stamped "CONTROLLED COPY" in red.
DESCRIPTION:	SOIC-8 NB	PAGE 1 OF 2

ON Semiconductor and ON are trademarks of Semiconductor Components Industries, LLC dba ON Semiconductor or its subsidiaries in the United States and/or other countries. ON Semiconductor reserves the right to make changes without further notice to any products herein. ON Semiconductor makes no warranty, representation or guarantee regarding the suitability of its products for any particular purpose, nor does ON Semiconductor assume any liability arising out of the application or use of any product or circuit, and specifically disclaims any and all liability, including without limitation special, consequential or incidental damages. ON Semiconductor does not convey any license under its patent rights nor the rights of others.

SOIC-8 NB
CASE 751-07
ISSUE AK

DATE 16 FEB 2011

- | | | | |
|--|---|---|---|
| <p>STYLE 1:
 PIN 1. EMITTER
 2. COLLECTOR
 3. COLLECTOR
 4. EMITTER
 5. EMITTER
 6. BASE
 7. BASE
 8. EMITTER</p> | <p>STYLE 2:
 PIN 1. COLLECTOR, DIE, #1
 2. COLLECTOR, #1
 3. COLLECTOR, #2
 4. COLLECTOR, #2
 5. BASE, #2
 6. EMITTER, #2
 7. BASE, #1
 8. EMITTER, #1</p> | <p>STYLE 3:
 PIN 1. DRAIN, DIE #1
 2. DRAIN, #1
 3. DRAIN, #2
 4. DRAIN, #2
 5. GATE, #2
 6. SOURCE, #2
 7. GATE, #1
 8. SOURCE, #1</p> | <p>STYLE 4:
 PIN 1. ANODE
 2. ANODE
 3. ANODE
 4. ANODE
 5. ANODE
 6. ANODE
 7. ANODE
 8. COMMON CATHODE</p> |
| <p>STYLE 5:
 PIN 1. DRAIN
 2. DRAIN
 3. DRAIN
 4. DRAIN
 5. GATE
 6. GATE
 7. SOURCE
 8. SOURCE</p> | <p>STYLE 6:
 PIN 1. SOURCE
 2. DRAIN
 3. DRAIN
 4. SOURCE
 5. SOURCE
 6. GATE
 7. GATE
 8. SOURCE</p> | <p>STYLE 7:
 PIN 1. INPUT
 2. EXTERNAL BYPASS
 3. THIRD STAGE SOURCE
 4. GROUND
 5. DRAIN
 6. GATE 3
 7. SECOND STAGE Vd
 8. FIRST STAGE Vd</p> | <p>STYLE 8:
 PIN 1. COLLECTOR, DIE #1
 2. BASE, #1
 3. BASE, #2
 4. COLLECTOR, #2
 5. COLLECTOR, #2
 6. EMITTER, #2
 7. EMITTER, #1
 8. COLLECTOR, #1</p> |
| <p>STYLE 9:
 PIN 1. EMITTER, COMMON
 2. COLLECTOR, DIE #1
 3. COLLECTOR, DIE #2
 4. EMITTER, COMMON
 5. EMITTER, COMMON
 6. BASE, DIE #2
 7. BASE, DIE #1
 8. EMITTER, COMMON</p> | <p>STYLE 10:
 PIN 1. GROUND
 2. BIAS 1
 3. OUTPUT
 4. GROUND
 5. GROUND
 6. BIAS 2
 7. INPUT
 8. GROUND</p> | <p>STYLE 11:
 PIN 1. SOURCE 1
 2. GATE 1
 3. SOURCE 2
 4. GATE 2
 5. DRAIN 2
 6. DRAIN 2
 7. DRAIN 1
 8. DRAIN 1</p> | <p>STYLE 12:
 PIN 1. SOURCE
 2. SOURCE
 3. SOURCE
 4. GATE
 5. DRAIN
 6. DRAIN
 7. DRAIN
 8. DRAIN</p> |
| <p>STYLE 13:
 PIN 1. N.C.
 2. SOURCE
 3. SOURCE
 4. GATE
 5. DRAIN
 6. DRAIN
 7. DRAIN
 8. DRAIN</p> | <p>STYLE 14:
 PIN 1. N-SOURCE
 2. N-GATE
 3. P-SOURCE
 4. P-GATE
 5. P-DRAIN
 6. P-DRAIN
 7. N-DRAIN
 8. N-DRAIN</p> | <p>STYLE 15:
 PIN 1. ANODE 1
 2. ANODE 1
 3. ANODE 1
 4. ANODE 1
 5. CATHODE, COMMON
 6. CATHODE, COMMON
 7. CATHODE, COMMON
 8. CATHODE, COMMON</p> | <p>STYLE 16:
 PIN 1. EMITTER, DIE #1
 2. BASE, DIE #1
 3. EMITTER, DIE #2
 4. BASE, DIE #2
 5. COLLECTOR, DIE #2
 6. COLLECTOR, DIE #2
 7. COLLECTOR, DIE #1
 8. COLLECTOR, DIE #1</p> |
| <p>STYLE 17:
 PIN 1. VCC
 2. V2OUT
 3. V1OUT
 4. TXE
 5. RXE
 6. VEE
 7. GND
 8. ACC</p> | <p>STYLE 18:
 PIN 1. ANODE
 2. ANODE
 3. SOURCE
 4. GATE
 5. DRAIN
 6. DRAIN
 7. CATHODE
 8. CATHODE</p> | <p>STYLE 19:
 PIN 1. SOURCE 1
 2. GATE 1
 3. SOURCE 2
 4. GATE 2
 5. DRAIN 2
 6. MIRROR 2
 7. DRAIN 1
 8. MIRROR 1</p> | <p>STYLE 20:
 PIN 1. SOURCE (N)
 2. GATE (N)
 3. SOURCE (P)
 4. GATE (P)
 5. DRAIN
 6. DRAIN
 7. DRAIN
 8. DRAIN</p> |
| <p>STYLE 21:
 PIN 1. CATHODE 1
 2. CATHODE 2
 3. CATHODE 3
 4. CATHODE 4
 5. CATHODE 5
 6. COMMON ANODE
 7. COMMON ANODE
 8. CATHODE 6</p> | <p>STYLE 22:
 PIN 1. I/O LINE 1
 2. COMMON CATHODE/VCC
 3. COMMON CATHODE/VCC
 4. I/O LINE 3
 5. COMMON ANODE/GND
 6. I/O LINE 4
 7. I/O LINE 5
 8. COMMON ANODE/GND</p> | <p>STYLE 23:
 PIN 1. LINE 1 IN
 2. COMMON ANODE/GND
 3. COMMON ANODE/GND
 4. LINE 2 IN
 5. LINE 2 OUT
 6. COMMON ANODE/GND
 7. COMMON ANODE/GND
 8. LINE 1 OUT</p> | <p>STYLE 24:
 PIN 1. BASE
 2. EMITTER
 3. COLLECTOR/ANODE
 4. COLLECTOR/ANODE
 5. CATHODE
 6. CATHODE
 7. COLLECTOR/ANODE
 8. COLLECTOR/ANODE</p> |
| <p>STYLE 25:
 PIN 1. VIN
 2. N/C
 3. REXT
 4. GND
 5. IOUT
 6. IOUT
 7. IOUT
 8. IOUT</p> | <p>STYLE 26:
 PIN 1. GND
 2. dv/dt
 3. ENABLE
 4. ILIMIT
 5. SOURCE
 6. SOURCE
 7. SOURCE
 8. VCC</p> | <p>STYLE 27:
 PIN 1. ILIMIT
 2. OVLO
 3. UVLO
 4. INPUT+
 5. SOURCE
 6. SOURCE
 7. SOURCE
 8. DRAIN</p> | <p>STYLE 28:
 PIN 1. SW_TO_GND
 2. DASIC OFF
 3. DASIC_SW_DET
 4. GND
 5. V_MON
 6. VBULK
 7. VBULK
 8. VIN</p> |
| <p>STYLE 29:
 PIN 1. BASE, DIE #1
 2. EMITTER, #1
 3. BASE, #2
 4. EMITTER, #2
 5. COLLECTOR, #2
 6. COLLECTOR, #2
 7. COLLECTOR, #1
 8. COLLECTOR, #1</p> | <p>STYLE 30:
 PIN 1. DRAIN 1
 2. DRAIN 1
 3. GATE 2
 4. SOURCE 2
 5. SOURCE 1/DRAIN 2
 6. SOURCE 1/DRAIN 2
 7. SOURCE 1/DRAIN 2
 8. GATE 1</p> | | |

DOCUMENT NUMBER:	98ASB42564B	Electronic versions are uncontrolled except when accessed directly from the Document Repository. Printed versions are uncontrolled except when stamped "CONTROLLED COPY" in red.
DESCRIPTION:	SOIC-8 NB	PAGE 2 OF 2

ON Semiconductor and  are trademarks of Semiconductor Components Industries, LLC dba ON Semiconductor or its subsidiaries in the United States and/or other countries. ON Semiconductor reserves the right to make changes without further notice to any products herein. ON Semiconductor makes no warranty, representation or guarantee regarding the suitability of its products for any particular purpose, nor does ON Semiconductor assume any liability arising out of the application or use of any product or circuit, and specifically disclaims any and all liability, including without limitation special, consequential or incidental damages. ON Semiconductor does not convey any license under its patent rights nor the rights of others.

MECHANICAL CASE OUTLINE

PACKAGE DIMENSIONS

ON Semiconductor®



SCALE 2:1

Micro8 CASE 846A-02 ISSUE K

DATE 16 JUL 2020



TOP VIEW

NOTE 3



SIDE VIEW



END VIEW

GENERIC MARKING DIAGRAM*

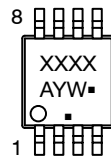

- XXXX = Specific Device Code
- A = Assembly Location
- Y = Year
- W = Work Week
- = Pb-Free Package

(Note: Microdot may be in either location)

*This information is generic. Please refer to device data sheet for actual part marking. Pb-Free indicator, "G" or microdot "▪", may or may not be present. Some products may not follow the Generic Marking.

NOTES:

1. DIMENSIONING AND TOLERANCING PER ASME Y14.5M, 2009.
2. CONTROLLING DIMENSION: MILLIMETERS
3. DIMENSION *b* DOES NOT INCLUDE DAMBAR PROTRUSION. ALLOWABLE PROTRUSION SHALL BE 0.10 mm IN EXCESS OF MAXIMUM MATERIAL CONDITION.
4. DIMENSIONS *D* AND *E* DO NOT INCLUDE MOLD FLASH, PROTRUSION OR GATE BURRS. MOLD FLASH, PROTRUSIONS, OR GATE BURRS SHALL NOT EXCEED 0.15 mm PER SIDE. DIMENSION *E* DOES NOT INCLUDE INTERLEAD FLASH OR PROTRUSION. INTERLEAD FLASH OR PROTRUSION SHALL NOT EXCEED 0.25 mm PER SIDE. DIMENSIONS *D* AND *E* ARE DETERMINED AT DATUM *F*.
5. DATUMS *A* AND *B* ARE TO BE DETERMINED AT DATUM *F*.
6. *A1* IS DEFINED AS THE VERTICAL DISTANCE FROM THE SEATING PLANE TO THE LOWEST POINT ON THE PACKAGE BODY.

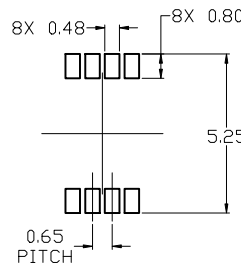

RECOMMENDED MOUNTING FOOTPRINT

For additional information on our Pb-Free strategy and soldering details, please download the ON Semiconductor Soldering and Mounting Techniques Reference Manual, SOLDERM/D.

DIM	MILLIMETERS		
	MIN.	NOM.	MAX.
A	---	---	1.10
A1	0.05	0.08	0.15
<i>b</i>	0.25	0.33	0.40
<i>c</i>	0.13	0.18	0.23
<i>D</i>	2.90	3.00	3.10
<i>E</i>	2.90	3.00	3.10
<i>e</i>	0.65 BSC		
<i>H_E</i>	4.75	4.90	5.05
<i>L</i>	0.40	0.55	0.70

STYLE 1:

- PIN 1. SOURCE
2. SOURCE
3. SOURCE
4. GATE
5. DRAIN
6. DRAIN
7. DRAIN
8. DRAIN

STYLE 2:

- PIN 1. SOURCE 1
2. GATE 1
3. SOURCE 2
4. GATE 2
5. DRAIN 2
6. DRAIN 2
7. DRAIN 1
8. DRAIN 1

STYLE 3:

- PIN 1. N-SOURCE
2. N-GATE
3. P-SOURCE
4. P-GATE
5. P-DRAIN
6. P-DRAIN
7. N-DRAIN
8. N-DRAIN

DOCUMENT NUMBER:	98ASB14087C	Electronic versions are uncontrolled except when accessed directly from the Document Repository. Printed versions are uncontrolled except when stamped "CONTROLLED COPY" in red.
DESCRIPTION:	MICRO8	PAGE 1 OF 1

ON Semiconductor and are trademarks of Semiconductor Components Industries, LLC dba ON Semiconductor or its subsidiaries in the United States and/or other countries. ON Semiconductor reserves the right to make changes without further notice to any products herein. ON Semiconductor makes no warranty, representation or guarantee regarding the suitability of its products for any particular purpose, nor does ON Semiconductor assume any liability arising out of the application or use of any product or circuit, and specifically disclaims any and all liability, including without limitation special, consequential or incidental damages. ON Semiconductor does not convey any license under its patent rights nor the rights of others.

ON Semiconductor and  are trademarks of Semiconductor Components Industries, LLC dba ON Semiconductor or its subsidiaries in the United States and/or other countries. ON Semiconductor owns the rights to a number of patents, trademarks, copyrights, trade secrets, and other intellectual property. A listing of ON Semiconductor's product/patent coverage may be accessed at www.onsemi.com/site/pdf/Patent-Marking.pdf. ON Semiconductor reserves the right to make changes without further notice to any products herein. ON Semiconductor makes no warranty, representation or guarantee regarding the suitability of its products for any particular purpose, nor does ON Semiconductor assume any liability arising out of the application or use of any product or circuit, and specifically disclaims any and all liability, including without limitation special, consequential or incidental damages. Buyer is responsible for its products and applications using ON Semiconductor products, including compliance with all laws, regulations and safety requirements or standards, regardless of any support or applications information provided by ON Semiconductor. "Typical" parameters which may be provided in ON Semiconductor data sheets and/or specifications can and do vary in different applications and actual performance may vary over time. All operating parameters, including "Typicals" must be validated for each customer application by customer's technical experts. ON Semiconductor does not convey any license under its patent rights nor the rights of others. ON Semiconductor products are not designed, intended, or authorized for use as a critical component in life support systems or any FDA Class 3 medical devices or medical devices with a same or similar classification in a foreign jurisdiction or any devices intended for implantation in the human body. Should Buyer purchase or use ON Semiconductor products for any such unintended or unauthorized application, Buyer shall indemnify and hold ON Semiconductor and its officers, employees, subsidiaries, affiliates, and distributors harmless against all claims, costs, damages, and expenses, and reasonable attorney fees arising out of, directly or indirectly, any claim of personal injury or death associated with such unintended or unauthorized use, even if such claim alleges that ON Semiconductor was negligent regarding the design or manufacture of the part. ON Semiconductor is an Equal Opportunity/Affirmative Action Employer. This literature is subject to all applicable copyright laws and is not for resale in any manner.

PUBLICATION ORDERING INFORMATION

LITERATURE FULFILLMENT:

Email Requests to: orderlit@onsemi.com

ON Semiconductor Website: www.onsemi.com

TECHNICAL SUPPORT

North American Technical Support:
Voice Mail: 1 800-282-9855 Toll Free USA/Canada
Phone: 011 421 33 790 2910

Europe, Middle East and Africa Technical Support:

Phone: 00421 33 790 2910

For additional information, please contact your local Sales Representative

