

Four-Output PTIC Control IC

TCC-404

Introduction

TCC-404 is a four-output high-voltage digital to analog control IC specifically designed to control and bias ON Semiconductor's Passive Tunable Integrated Circuits (PTICs).

These tunable capacitor control circuits are intended for use in mobile phones and dedicated RF tuning applications. The implementation of ON Semiconductor's tunable circuits in mobile phones enables significant improvement in terms of antenna radiated performance.

The tunable capacitors are controlled through a bias voltage ranging from 1 V to 28 V. The TCC-404 high-voltage PTIC control IC has been specifically designed to cover this need, providing four independent high-voltage outputs that control up to four different tunable PTICs in parallel. The device is fully controlled through a MIPI RFFE digital interface.

Key Features

- Controls ON Semiconductor's PTIC Tunable Capacitors
- Compliant with Timing Needs of Cellular and Other Wireless System Requirements
- 30 V Integrated Boost Converter with Four up to 28 V Programmable DAC Outputs
- Low Power Consumption
- MIPI RFFE Interfaces (1.8 V) with 26 MHz Read and 52 MHz Write
- Automatic On-chip Turbo Calculation – Simplified Turbo Messaging
- ASDIV Switch Support over GPIO Toggle or RFFE Command to facilitate Dual Settings for two Antennae (Dual Radio)
- Integrated Diode and Reduced External Components
- Reduced Value 2.2 μ H – 4.7 μ H Inductor
- Small Form Factor 1575 x 1025 μ m, WLCSP 4x3 Array
- This is a Pb-Free Device

Typical Applications

- Multi-band, Multi-standard, Advanced and Simple Mobile Phones
- Tunable Antenna Matching Networks
- Compatible with Closed-loop and Open-loop Antenna Tuner Applications



ON Semiconductor®

www.onsemi.com



WLCSP12
CASE 567WF

MARKING DIAGRAM

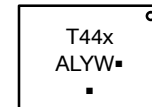

T44x= Specific Device Code

x = a or b

A = Assembly Location

L = Wafer Lot

Y = Year

W = Work Week

▪ = Pb-Free Package

(Note: Microdot may be in either location)

ORDERING INFORMATION

See detailed ordering and shipping information on page 39 of this data sheet.

TCC-404

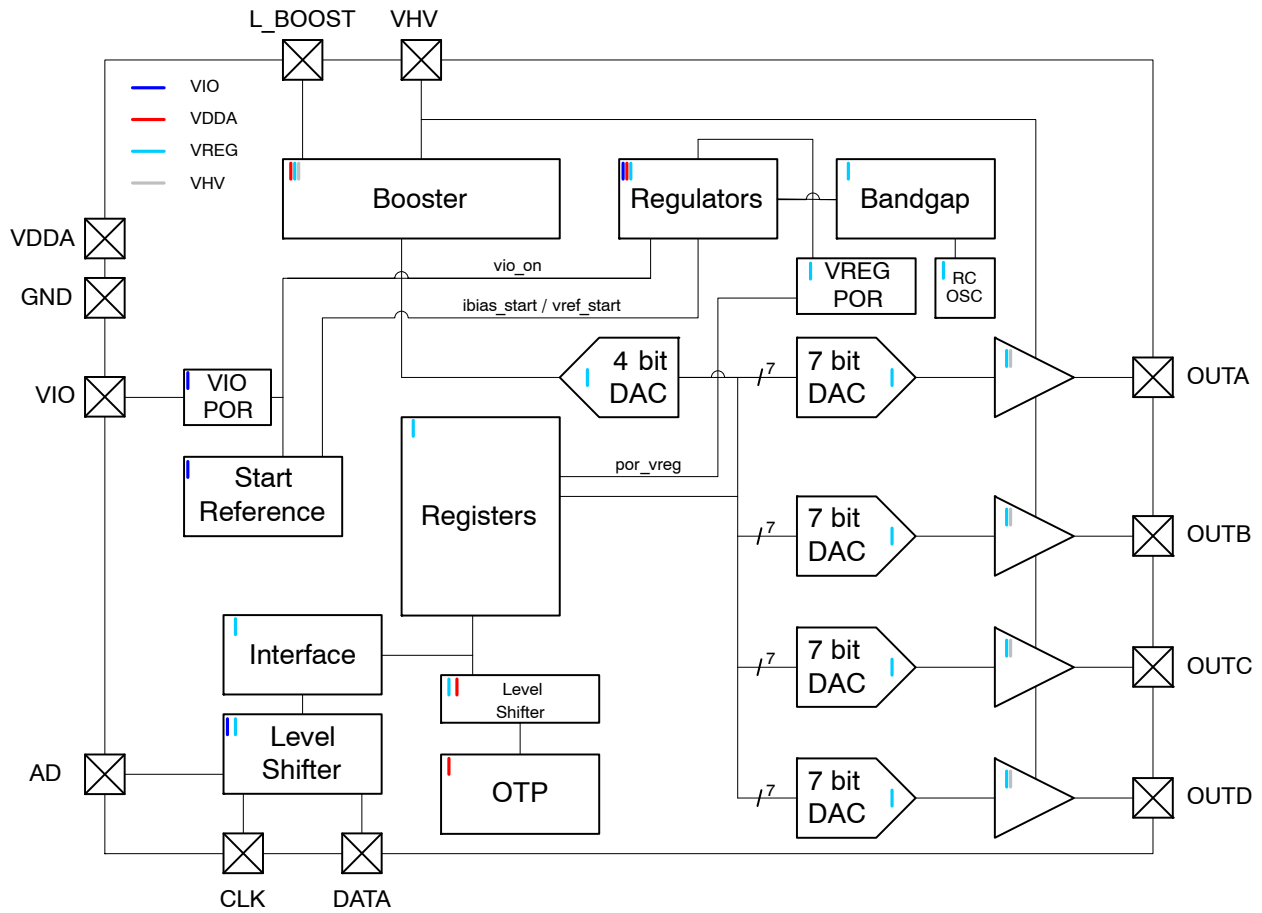

Figure 1. Control IC Functional Block Diagram

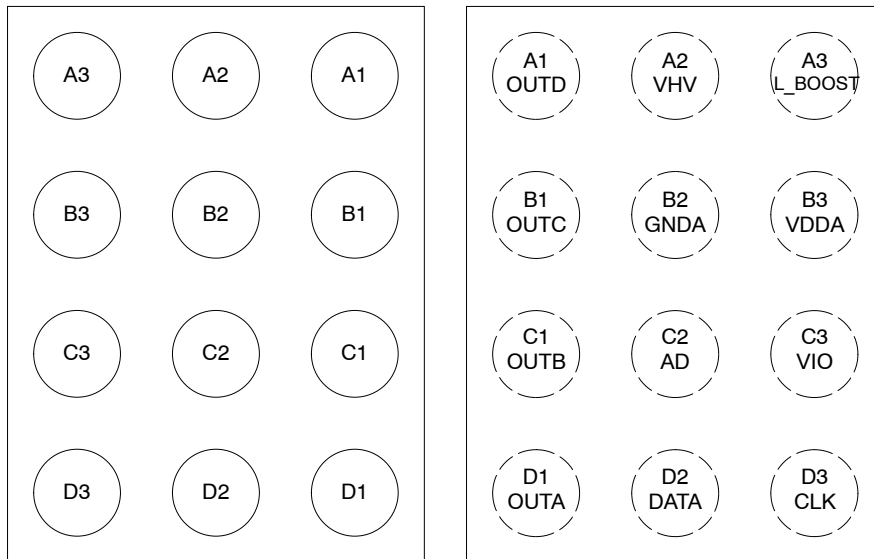

Figure 2. RDL Padout, Bump Side View (left), PCB footprint (right), with RDL Bump Assignment

TCC-404

RDL Pin Out

Table 1. PAD DESCRIPTIONS

RDL	Name	Type	Description
A1	OUTD	AOH	High Voltage Output D
A2	VHV	AOH / AIH	Boost High Voltage (can be forced externally)
A3	L_BOOST	AOH	Boost Inductor
B1	OUTC	AOH	High Voltage Output C
B2	GND A	P	Analog Ground
B3	VDDA	P	Analog Supply
C1	OUTB	AOH / AI	High Voltage Output B
C2	AD	DIO	Antenna Diversity (Note 1)
C3	VIO	P	Digital IO Supply
D1	OUTA	AOH / AI	High Voltage Output A
D2	DATA	DIO	MIPI RFFE Digital IO
D3	CLK	DI	MIPI RFFE Clock

Legend: Pad Types

AIH= High Voltage Analog Input
AOH= High Voltage Analog Output
DI= Digital Input
DIO= Digital Input/Output (IO)
P= Power

1. To be grounded if not utilized.

ELECTRICAL PERFORMANCE SPECIFICATIONS

Table 2. ABSOLUTE MAXIMUM RATINGS

Symbol	Parameter	Rating	Unit
VDDA	Analog Supply Voltage	-0.3 to +5.5	V
VIO	IO Reference Supply Voltage	-0.3 to +2.5	V
V _{I/O}	Input Voltage Logic Lines (DATA, CLK)	-0.3 to VIO + 0.3	V
V _{HVH}	VHV Maximum Voltage	-0.3 to 33	V
V _{ESD} (HBM)	Human Body Model, JESD22-A114, All I/O	2,000	V
T _{STG}	Storage Temperature	-55 to +150	°C
T _{AMB_OP_MAX}	Max Operating Ambient Temperature without Damage	+110	°C

Stresses exceeding those listed in the Maximum Ratings table may damage the device. If any of these limits are exceeded, device functionality should not be assumed, damage may occur and reliability may be affected.

Table 3. RECOMMENDED OPERATING CONDITIONS

Symbol	Parameter	Rating			Unit
		Min	Typ	Max	
T _{AMB_OP}	Operating Ambient Temperature	-30	-	+85	°C
T _{J_OP}	Operating Junction Temperature	-30	-	+125	°C
VDDA	Analog Supply Voltage	2.3	-	5.5	V
VIO	IO Reference Supply Voltage	1.62	-	1.98	V

Functional operation above the stresses listed in the Recommended Operating Ranges is not implied. Extended exposure to stresses beyond the Recommended Operating Ranges limits may affect device reliability.

Table 4. DC CHARACTERISTICS (T_A = -30 to +85°C; V_{OUTX} = 15 V for each output; 2.3 V < VDDA < 5.5 V; V_{IO} = 1.8 V; R_{LOAD} = equivalent series load of 5.6 kΩ and 2.7 nF; C_{HV} = 22 nF; L_{BOOST} = 2.2 μH; unless otherwise specified)

Symbol	Parameter	Min	Typ	Max	Unit	Comment
--------	-----------	-----	-----	-----	------	---------

SHUTDOWN MODE

I _{VDDA}	VDDA Supply Current	-	-	1.5	μA	VIO Supply is Low
I _{L_BOOST}	L_BOOST Leakage	-	-	1.5		
I _{BATT}	Battery Current	-	-	2.5		
I _{VIO}	VIO Supply Current	-1	-	1		
I _{CLK}	CLK Leakage	-1	-	1		
I _{DATA}	DATA Leakage	-1	-	1		

ACTIVE MODE

I _{BATT}	Average battery current, 2 outputs actively switching 16 V for 1205 μs to 2 V for 1705 μs to 8 V for 1705 μs	-	1200	1600	μA	At VHV = 20 V VDDA = 3.3 V
I _{BATT_SS0}	Average battery current, 4 outputs @ 0 V steady state	-	750	950		At VHV = 20 V VDDA = 3.3 V
I _{BAT_SS2}	Average battery current, 4 outputs @ 2 V steady state	-	850	1200	μA	At VHV = 20 V VDDA = 3.3 V
I _{BATT_SS16}	Average battery current, 4 outputs @ 16 V steady state	-	1000	1300		At VHV = 20 V VDDA = 3.3 V
I _{L_BOOST}	Average inductor current, 2 outputs actively switching 16 V for 1205 μs to 2 V for 1705 μs to 8 V for 1705 μs and 3 outputs are @ 16 V steady state	-	1000	1400		At VHV = 20 V VDDA = 3.3 V
I _{L_BOOST_SS0}	Average inductor current, 4 outputs @ 0 V steady state	-	550	750		At VHV = 20 V VDDA = 3.3 V
I _{L_BOOST_SS2}	Average inductor current, 4 outputs @ 2 V steady state	-	700	1000		At VHV = 20 V VDDA = 3.3 V
I _{L_BOOST_SS16}	Average inductor current, 4 outputs @ 16 V steady state	-	850	1100		At VHV = 20 V VDDA = 3.3 V
I _{VIO_INACT}	VIO average inactive current	-	-	3		VIO is high, no bus activity
I _{VIO_ACTIVE}	VIO average active current	-	-	250	VIO = 1.8 V, master sending data at 26 MHz	

LOW POWER MODE

I _{VDDA}	VDDA Supply Current	-	-	25	μA	
I _{L_BOOST}	L_BOOST Leakage	-	-	6		
I _{BATT}	Battery Current	-	-	31		I _{VDDA} + I _{L_BOOST}
I _{VIO}	VIO Supply Current	-	-	3		No bus activity

Product parametric performance is indicated in the Electrical Characteristics for the listed test conditions, unless otherwise noted. Product performance may not be indicated by the Electrical Characteristics if operated under different conditions.

TCC-404

Table 5. BOOST CONVERTER CHARACTERISTICS

(VDDA from 2.3 V to 5.5 V; V_{IO} = 1.8 V; T_A = -30 to +85°C; C_{HV} = 22 nF; L_{BOOST} = 2.2 μH; unless otherwise specified)

Symbol	Parameter	Conditions	Min	Typ	Max	Unit
VHV_min	Minimum programmable output voltage (average), DAC Boost = 0h	Active mode	-	15	-	V
VHV_max	Maximum programmable output voltage (average), DAC Boost = Fh	Active mode	-	30	-	
Resolution	Boost voltage resolution	4-bit DAC	-	1	-	
I _{L_BOOST_LIMIT}	Inductor current limit		-	300	-	mA

Table 6. ANALOG OUTPUTS (OUT A, OUT B, OUT C, OUT D)

(VDDA from 2.3 V to 5.5 V; V_{IO} = 1.8 V; V_{HV} = 26 V; T_A = -30 to +85°C; R_{load} = ∞ unless otherwise specified)

Parameter	Description	Min	Typ	Max	Unit	Comment
SHUTDOWN MODE						
Z _{OUT}	OUT A, OUT B, OUT C, OUT D output impedance	7	-	-	MΩ	DAC disabled
ACTIVE MODE						
V _{OH}	Maximum output voltage	-	24 or 28	-	V	DAC A, B, C, D = 7Fh, DAC Boost = Fh, I _{OH} < 10 μA
V _{OL}	Minimum output voltage	-	-	1	V	DAC A, B, C, D = 01h, DAC Boost = 0h to Fh, I _{OH} < 10 μA
Slew Rate		-	3	10	μs	2 V to 20 V step, measured at V _{OUT} = 15.2 V, R _{LOAD} = equivalent series load of 5.6 kΩ and 2.7 nF, Turbo enabled
R _{PD}	OUT A, OUT B, OUT C, OUT D set in pull-down mode	-	-	1000	Ω	DAC A, B, C, D = 00h, DAC Boost = 0h to Fh, selected output(s) is disabled
Resolution	Voltage resolution (1-bit)	-	189 / 220	-	mV	(1 LSB = 1-bit) based on V _{OH} selection
V _{OFFSET}	Zero scale, least squared best fit	-1	-	+1	LSB	
Gain Error		-3.0	-	+3.0	%V _{OUT}	1 V to 24 V with 26 V VHV
DNL	Differential non-linearity least squared best fit	-0.9	-	+0.9	LSB	1 V to 24 V with 26 V VHV
INL	Integral non-linearity least squared best fit	-1	-	+1	LSB	1 V to 24 V with 26 V VHV
I _{SC}	Over current protection	-	5	65	mA	Any DAC output shorted to ground
V _{RIPPLE}	Output ripple with all outputs at steady state	-	-	40	mV RMS	1 V to 24 V with 26 V VHV

THEORY OF OPERATION

Overview

The control IC outputs are directly controlled by programming the four DACs (DAC A, DAC B, DAC C, DAC D) through the digital interface.

The DAC stages are driven from a reference voltage, generating an analog output voltage driving a high-voltage amplifier supplied from the boost converter (see Figure 1 – Control IC Functional Block Diagram).

The control IC output voltages can be programmed to scale from 0 V to 24 V, with 127 steps of 189 mV. The nominal control IC output can be approximated to 189 mV x (DAC value).

The control IC output voltages can also be programmed to scale from 0 V to 28 V, with 127 steps of 220 mV. The nominal control IC output can be approximated to 220 mV x (DAC value).

For performance optimization the boost output voltage (VHV) can be programmed to levels between 15 V and 30 V via the DAC_boost register (4 bits with 1 V steps). The startup default level for the boosted voltage is VHV = 28 V.

For proper operation and to avoid saturation of the output devices and noise issues, it is recommended to operate the boosted VHV voltage at least 2 V (>4 V [6 V recommended] if using Turbo-Charge Mode) above the highest programmed V_{OUT} voltage of any of the three outputs.

Operating Modes

The following operating modes are available:

1. **Shutdown Mode:** All circuit blocks are off, the DAC outputs are disabled and placed in high Z state and current consumption is limited to minimal leakage current. The shutdown mode is entered upon initial application of VDDA or upon VIO being placed in the low state. The contents of the registers are not maintained in shutdown mode.

2. **Startup Mode:** Startup is only a transitory mode. Startup mode is entered upon a VIO high state. In startup mode all registers are reset to their default states, the digital interface is functional, the boost converter is activated, outputs OUT A, OUT B, OUT C and OUT D are disabled and the DAC outputs are placed in a high Z state. Control software can request a full hardware and register reset of the TCC-404 by sending an appropriate PWR_MODE command to direct the chip from either the active mode or the low power mode to the startup mode. From the startup mode the device automatically proceeds to the active mode.
3. **Active Mode:** All blocks of the TCC-404 are activated and the DAC outputs are fully controlled through the digital interface, DACs remain off until enabled. The DAC settings can be dynamically modified and the HV outputs will be adjusted according to the specified timing diagrams. Each DAC can be individually controlled and/or switched off according to application requirements. Active mode is automatically entered from the startup mode. Active mode can also be entered from the low power mode under control software command.
4. **Low Power Mode:** In low power mode the serial interface stays enabled, the DAC outputs are disabled and are placed in a high Z state and the boost voltage circuit is disabled. Control software can request to enter the low power mode from the active mode by sending an appropriate PWR_MODE command. The contents of all registers are maintained in the low power mode.

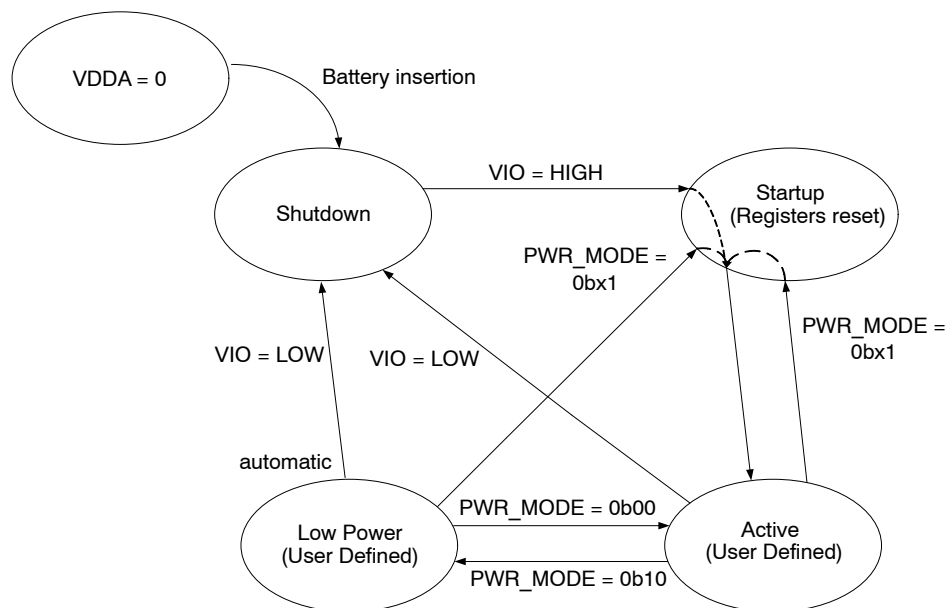

Figure 3. Modes of Operation

TCC-404

VDDA Power-On Reset (POR)

Upon application of VDDA, TCC-404 will be in shutdown mode. All circuit blocks are off and the chip draws only minimal leakage current.

VIO Power-On Reset and Startup Conditions

A high level on VIO places the chip in startup mode which provides a POR to TCC-404. POR resets all registers to their default settings. VIO POR also resets the serial interface circuitry. POR is not a brown-out detector and VIO needs to be brought back to a low level to enable the POR to trigger again.

Table 7. VIO POWER-ON RESET AND STARTUP

Register	Default State for VIO POR	Comment
DAC Boost	[1101]	VHV = 28 V
Power Mode	[01]>[00]	Transitions from shutdown to startup and then automatically to active mode
DAC Enable	[0000]	V _{OUT} A, B, C, D Disabled
DAC A		Output in High-Z Mode
DAC B		Output in High-Z Mode
DAC C		Output in High-Z Mode
DAC D		Output in High-Z Mode

VIO Shutdown

A low level at any time on VIO places the chip in shutdown mode in which all circuit blocks are off. The contents of the registers are not maintained in shutdown mode.

Table 8. VIO THRESHOLDS (VDDA from 2.3 V to 5.5 V; T_A = -30 to +85°C unless otherwise specified)

Parameter	Description	Min	Typ	Max	Unit	Comments
VIORST	VIO Low Threshold	-	-	0.2	V	When VIO is lowered below this threshold level the chip is reset and placed into the shutdown mode

Power Supply Sequencing

The VDDA input is typically directly supplied from the battery and thus is the first on. After VDDA is applied and before VIO is applied to the chip, all circuits are in the shutdown mode and draw minimum leakage currents. Upon application of VIO, the chip automatically starts up using default settings and is placed in the active state waiting for a command via the serial interface.

Table 9. TIMING (VDDA from 2.3 V to 5.5 V; V_{IO} = 1.8 V; T_A = -30 to +85°C; OUT A, OUT B, OUT C, OUT D; CHV = 47 nF; L_{BOOST} = 2.2 μH; VHV = 20 V; Turbo-Charge mode off unless otherwise specified)

Parameter	Description	Min	Typ	Max	Unit	Comments
T _{POR_VREG}	Internal bias settling time from shutdown to active mode	-	50	120	μs	For info only
T _{BOOST_START}	Time to charge CHV @ 95% of set VHV	-	130	-	μs	For info only
T _{SD_TO_ACT}	Startup time from shutdown to active mode	-	180	250	μs	
T _{SET+}	Timing for a 2 V to 16 V transition, measured when voltage reaches within 5% of target voltage, measured between the R (5.6 kΩ) and C (2.7 nF) of an equivalent PTIC series load.	-	50	60	μs	Voltage settling time connected on V _{OUT} A, B, C, D
T _{SET-}	Timing for a 16 V to 2 V transition, measured when voltage reaches within 5% of target voltage, measured between the R (5.6 kΩ) and C (2.7 nF) of an equivalent PTIC series load.	-	50	60	μs	Effective PTIC tuning voltage settling time, measured between an equivalent R and C PTIC load
T _{SET+}	Output A, B, C, D positive settling time with Turbo	-	35	-	μs	Voltage settling time connected on V _{OUT} A, B, C, D
T _{SET-}	Output A, B, C, D negative settling time with Turbo	-	35	-	μs	Voltage settling time connected on V _{OUT} A, B, C, D

TCC-404

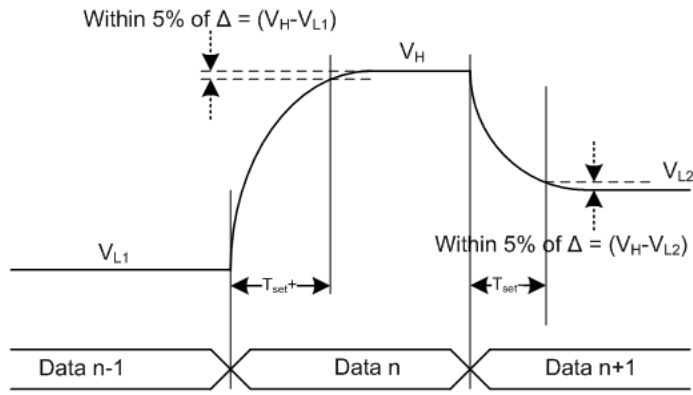

Figure 4. Output Settling Diagram

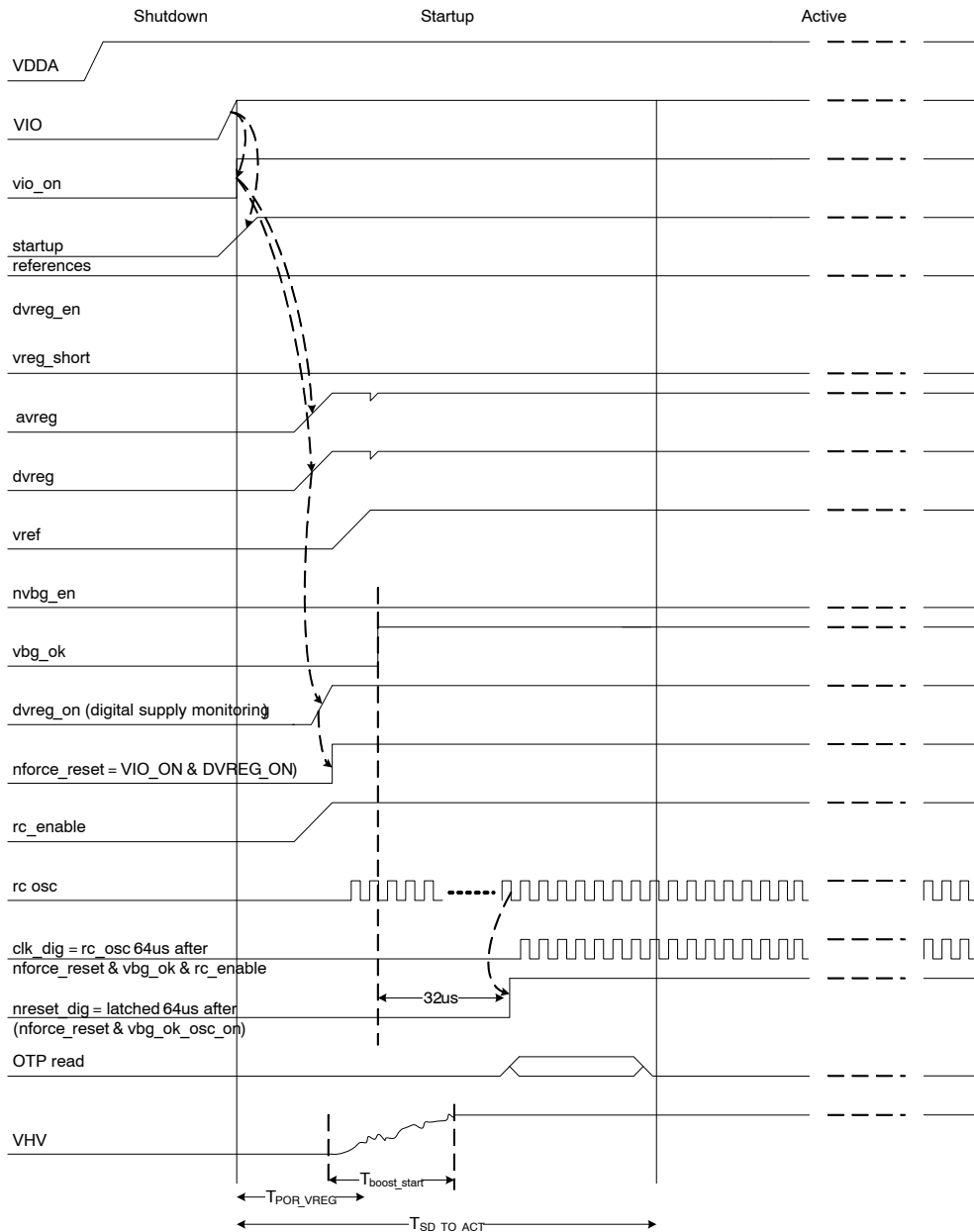

Figure 5. Startup Timing Diagram

Boost Control

TCC-404 integrates an asynchronous current control boost converter. It operates in a discontinuous mode and features spread-spectrum circuitry for Electro-Magnetic Interference (EMI) reduction.

Boost Output Voltage (VHV) Control Principle

The asynchronous control starts the boost converter as soon as the VHV voltage drops below the reference set by the 4-bit DAC and stops the boost converter when the VHV voltage rises above the reference again.

Due to the slow response time of the control loop, the VHV voltage may drop below the set voltage before the control loop compensates for it. In the same manner, VHV can rise higher than the set value. This effect may reduce the maximum output voltage available. Please refer to Figure 6 below.

The asynchronous control reduces switching losses and improves the output (VHV) regulation of the DC/DC converter under light load, particularly in the situation where TCC-404 only maintains the output voltages to fixed values.

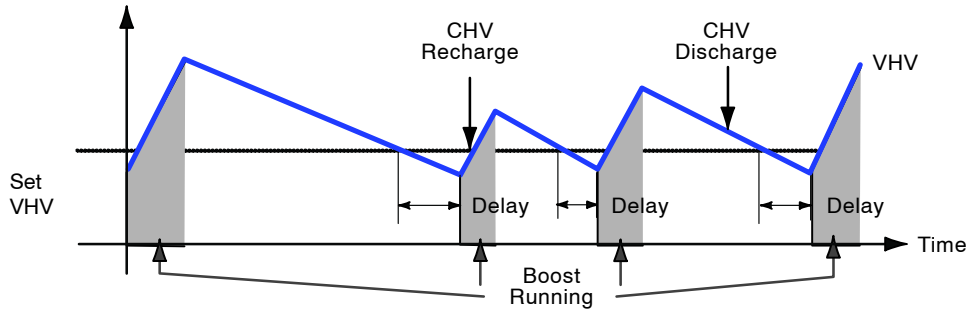

Figure 6. VHV Voltage Waveform

High Impedance (High Z) Feature

In shutdown mode the OUT pins are set to a high impedance mode (high Z). Following is the principle of operation for the control IC:

1. The DAC output voltage V_{OUT} is defined by:

$$V_{OUT} = \frac{\text{DAC code}}{127} \times 24 \text{ or } 28 \text{ V} \quad (\text{eq. 1})$$

2. The RFFE_REG_0x05 controls the range of the DAC (24 or 28 V).
3. The voltage VHV defines the maximum supply voltage of the DAC supply output regulator and is set by a 4-bit control.
4. The maximum DAC DC output voltage V_{OUT} is limited to $(VHV - 2 \text{ V})$. DAC can achieve higher output voltages, but timing is not maintained for swings above $VHV - 2 \text{ V}$.
5. The minimum output DAC voltage V_{OUT} is 1.0 V max.

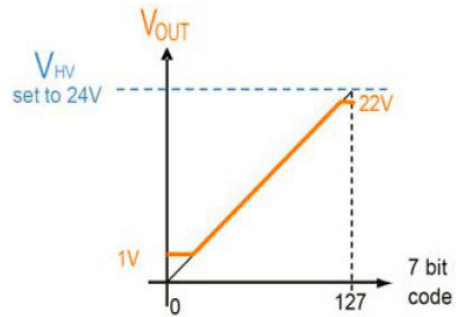

Figure 7. DAC Output Range Example A

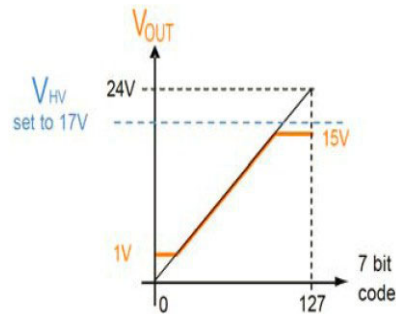

Figure 8. DAC Output Range Example B

Digital Interface

The control IC is fully controlled through a digital interface (DATA, CLK). The digital interface is described in the following sections of this document.

Turbo-Charge Mode

The TCC-404 control IC has an autonomous Turbo-Charge Mode that significantly shortens the system settling time when changing programming voltages.

In Turbo-Charge Mode the DAC output target voltage is temporarily set to either a delta voltage above or a delta voltage below the actual desired target. The delta voltage is 4 volts.

After the DAC value message is received, the delta voltage is calculated by hardware, and is applied in digital format to the input of the DAC, right after trigger is received. The period for which the delta voltage is maintained to the input of the DAC, the Turbo time, is autonomously calculated and based on the following considerations:

- **DACA CONTROL[1:0] / DACB CONTROL[1:0] / DACC CONTROL[1:0] / DACD CONTROL[1:0] :**
These are the DAC operational mode control bits. The bit[0] in the control defines the step size of the DAC as 189 mV (0) or 220 mV (1). The bit[1] in the control enables the autonomous turbo mode. In order the Turbo operation to be enabled each DAC has to have this bit set. Otherwise the DAC values are applied without Turbo.
- **TurboUpMultiplier[2:0]:** If the Turbo direction is UP, the base autonomous Turbo time calculated is multiplied with this configuration factor. The default state of this configuration provides the optimum time for the Turbo UP operation. The factor decoding is as below:
 - ‘000’: multiplication by 1.0
 - ‘001’: multiplication by 1.125
 - ‘010’: multiplication by 1.25
 - ‘011’: multiplication by 1.375 (default)
 - ‘100’: multiplication by 1.5
 - ‘101’: multiplication by 1.625
 - ‘110’: multiplication by 1.75
 - ‘111’: multiplication by 1.875
- **TurboDownMultiplier[2:0]:** If the Turbo direction is DOWN, the base autonomous Turbo time calculated is multiplied with this configuration factor. The default state of this configuration provides the optimum time for the Turbo DOWN operation. The factor decoding is as below:
 - ‘000’: multiplication by 1.0
 - ‘001’: multiplication by 1.125
 - ‘010’: multiplication by 1.25
 - ‘011’: multiplication by 1.375 (default)
 - ‘100’: multiplication by 1.5
 - ‘101’: multiplication by 1.625
 - ‘110’: multiplication by 1.75
 - ‘111’: multiplication by 1.875

- **TurboDownFactor[1:0]:** If the Turbo direction is DOWN and the target voltage is below 4V the Turbo time calculation further adjusted with this factor. The default setting provides the optimum Turbo DOWN operation.
- **GL_A / GL_B / GL_C / GL_D:** These are the DAC update mode configuration fields, which need to be set to turbo mode at the new DAC value update and prior to the SW trigger (optional). These bits are part of the DAC value register. If they are set to 0, the DAC is in Turbo Mode, as long as the corresponding DAC CONTROL register is configured so. If the Turbo is not enabled the DAC value is applied as is.
- The Turbo UP or DOWN voltage is decided based on the comparison of the new DAC value and the old DAC value. If the new value is greater, the turbo direction will be UP. Otherwise it will be DOWN. In case of both DAC values being equal, there is no DAC update applied. After a turbo request is received, any trigger will start the turbo output transition. The trigger could be:
 - ♦ A MIPI-RFFE software trigger controlled by RFFE_PM_TRIG register
 - ♦ An AD pad toggle if the GPIO is enabled as trigger source or MIPI-RFFE command is sent to trigger the AD.
 - ♦ An internal generated trigger after the corresponding DAC value is updated, as described in section **DAC Update Triggering**.

The DAC values send by digital turbo-charge logic to DACs are:

- During turbo-charge delay duration the value applied is “DAC_new ±4 V” (the polarity of the 4 V turbo will depend on if turbo charge is up or down)
- If DAC_new > DAC_old, and DAC_new+4 V is exceeding the word length of the DAC, it is saturated to max value possible.
- If DAC_new < DAC_old, and DAC_new-4 V is a negative number, a DAC value of 0 is applied.
 - ♦ After turbo-charge delay duration the value applied is the actual DAC_new.

Table 10. GLIDE TIMER STEP DURATION

DAC GLIDE TIMER [4:0]					Glide Step Duration in Glide Mode [μ s]
Bit 4	Bit 3	Bit 2	Bit 1	Bit 0	
0	0	0	0	0	2
0	0	0	0	1	4
0	0	0	1	0	6
0	0	0	1	1	8
0	0	1	0	0	10
0	0	1	0	1	12
0	0	1	1	0	14
0	0	1	1	1	16
0	1	0	0	0	18
0	1	0	0	1	20
0	1	0	1	0	22
0	1	0	1	1	24
0	1	1	0	0	26
0	1	1	0	1	28
0	1	1	1	0	30
0	1	1	1	1	32
1	0	0	0	0	34
1	0	0	0	1	36
1	0	0	1	0	38
1	0	0	1	1	40
1	0	1	0	0	42
1	0	1	0	1	44
1	0	1	1	0	46
1	0	1	1	1	48
1	1	0	0	0	50
1	1	0	0	1	52
1	1	0	1	0	54
1	1	0	1	1	56
1	1	1	0	0	58
1	1	1	0	1	60
1	1	1	1	0	62
1	1	1	1	1	64

Transition from Turbo to Turbo or Immediate Update

In the event a new trigger is received during a turbo transition, the ongoing turbo operation is halted and the new DAC value is applied immediately. There won't be any Turbo and the hi_slew is kept low.

Transition from Turbo to Glide

In the event that a new glide transition is triggered during a turbo event, then the turbo process is stopped and the current target value is set at the DAC output immediately without hi_slew. The new glide is started from this value.

DAC Disable during Turbo (including active to low power mode transition)

If the DAC, which is in Turbo is disabled, the target DAC value is immediately applied without hi_slew. The DAC does not continue with the Turbo when it is re-enabled.

Turbo coming out of Low Power Mode

If the DAC, which is in low power mode is triggered with a new Turbo DAC update, the DAC_old value is taken as 0V in autonomous Turbo calculation.

Glide Mode

The TCC-404 control IC has a Glide Mode that significantly extends the system transition time when changing programming voltages.

Glide Mode is controlled by the following registers:

- **GLIDE TIMER STEP SIZE [4:0]:** This register is used only in glide mode and shared between all DACs. It defines the step duration of each glide step. If each DAC is updated over and over with the same glide step, these fields do NOT need to be updated at each DAC update. The various configuration values are listed in Table 10.
- **GL_A / GL_B / GL_C / GL_D:** These are the DAC update mode configuration fields, which need to be set to glide mode at the new DAC value update and prior to the SW trigger (optional). These bits are part of the DAC value register. If they are set to 1, the DAC is in glide mode.

After a Glide request is received, any trigger will start the Glide output transition.

The trigger could be:

- a MIPI-RFFE software trigger controlled by RFFE_PM_TRIG register
- An AD pad toggle if the GPIO is enabled as trigger source or MIPI-RFFE command is sent to trigger the AD
- an internal generated trigger after the corresponding DAC value is updated, as described in a later section.

Immediately after the trigger, the DAC_old value is loaded in the MSB's of the upper byte of a 15 bit accumulator, while the lower byte of accumulator is being reset to 0x00.

At the same time a count step is calculated:

$GLIDE_STEP[6:0] = DAC_new - DAC_old;$ if $DAC_new > DAC_old$

$GLIDE_STEP[6:0] = DAC_old - DAC_new;$ if $DAC_new < DAC_old$

$ACCUMULATOR[14:0] = DAC_old, 0x00;$

NOTE: Glide is disabled if $DAC_new = DAC_old$.

From the moment the trigger is received, a tick is generated internally, with a frequency controlled by the GLIDE TIMER STEP SIZE register. Each DAC has its own tick generator running independently of the other DAC. Each time a trigger is received for a DAC, the setting of the GLIDE TIMER STEP SIZE register is sampled in a counter

dedicated to that DAC. Any update of the GLIDE TIMER STEP SIZE register after trigger is received will be ignored until the next trigger is received

Each time a tick is generated, the content of the accumulator is either incremented or decremented, depending whether DAC_new is either bigger or smaller than DAC_old.

$ACCUMULATOR[14:0] = ACCUMULATOR[14:0] + GLIDE_STEP;$ if $DAC_new > DAC_old$

$ACCUMULATOR[14:0] = ACCUMULATOR[14:0] - GLIDE_STEP;$ if $DAC_new < DAC_old$

Each time a tick is generated, the output of the DAC[6:0] is updated with the value of ACCUMULATOR[14:8];

The Gliding process continues until, upper 7 bits of the accumulator matches the value of the DAC_new.

$ACCUMULATOR[14:8] \geq DAC_new,$ when $DAC_new > DAC_old$

$ACCUMULATOR[14:8] \leq DAC_new,$ when $DAC_new < DAC_old$

The Glide timer will reference the 2 MHz clock divided to provide between 2 μ s and 64 μ s per glide step.

Each DAC is independent in terms of its switching operation, thus each DAC may be independently programmed for Normal, Turbo or Glide regardless of the switching operation of the other DACs.

Transition from Glide to Glide

In the event a new glide request is received during a glide transition, the ongoing glide operation is halted and the new glide operation is started from the DAC value, where the previous glide has left off. The DAC timers can be updated to a new value at the trigger.

Transition from Glide to Turbo or Normal Switching

In the event that a new Normal switching or Turbo DAC value is received during a Glide transition, then the Glide process is stopped and the DAC immediately switches to the newly received target value without Turbo or Glide. The hi_slew is not applied.

DAC Disable during Glide (including active to low power mode transition)

If the DAC, which is gliding is disabled, the DAC value holds on to the value where the glide stops. The DAC does not continue with the glide when it is re-enabled. It drives the last calculated DAC value without a hi_slew.

ASDIV – Dual Radio Control

The TCC-404 carries two sets of registers (Radio0 and Radio1) for only DAC_A/B/C/D Value Registers. The Radio0 set consists of RFFE_REG_0x06, RFFE_REG_0x07, RFFE_REG_0x08, RFFE_REG_0x09. The Radio1 set consists of RFFE_REG_0x0A, RFFE_REG_0x0B, RFFE_REG_0x0C, RFFE_REG_0x0D. These registers set the actual DAC values when their set is active and control the glide turn on and off.

The Dual Radio Control field at RFFE_REG_0x0E register governs the operation of the Dual Radio functionality. The AD pad can be enabled to switch between the Radio0 and Radio1 values according to the state of this pad. The reset state of this register is to disable the Dual Radio operation.

The control register has the following states:

0: The AD (Antenna Diversity) pad is disabled. There is no toggling between the Radio0 and Radio1 Registers. The Radio0 DAC registers are used as the active shadow registers for trigger.

1: The AD (Antenna Diversity) pad is enabled. The Radio0 register set is triggered when the pad input transitions into “0” from “1”. The Radio1 register set is triggered when the pad input transitions into “1” from “0”. The RC clock domain retimed AD pad value defines which set of shadow registers are active for all triggering purposes.

2: The AD (Antenna Diversity) pad is disabled. The Radio0 DAC registers are triggered in any transition into this control value. Rewriting of the same value does not issue a re-trigger. The RC clock domain retimed register activates the Radio0 set of registers. A SW trigger or immediate update captures these Radio0 shadow content into active registers in any consecutive triggering.

3: The AD (Antenna Diversity) pad is disabled. The Radio1 DAC registers are triggered in any transition into this control value. . Rewriting of the same value does not issue a re-trigger. The RC clock domain retimed register activates the Radio1 set of registers. A SW trigger or immediate update captures these Radio1 shadow content into active registers in any consecutive triggering.

The AD pad does not have any pull on it. It has to be physically connected to ground or VIO supply externally. The RC domain retimed state of the dual radio control can be observed through the upper nibble of the Dual radio control register (0x0E). A write into this field is ignored. The sampling of the AD pad is blocked during any RFFE communication to prevent trigger collision between the AD pad and the RFFE Interface. Since the conventional triggering occurs at the end of an RFFE frame, this aligns all sources of triggering.

If a DAC is disabled, the dual radio triggering does not apply to this DAC. It holds the last triggered active register value prior to getting disabled.

ASDIV – Dual Radio Operation Disabled (State0)

This is the single Radio operation, where the Radi0 set of registers in address range 0x06 to 0x09 are the shadow registers mapped to active registers. They are triggered by either immediate update (depending on SW trigger masking) or SW trigger.

The AD pad state is still captured at RC oscillator clock domain continuously. This register output can still be read over the RFFE interface at the dual radio control address (0x0E). This reading does not reflect the active DAC register. The active DAC register is enforced to be the Radio0 set.

This allows the AD pad to be utilized for any system signal state detection when the dual radio is not active.

In this mode of operation the data read back from the Radio0 or Radio1 set of registers always returns the triggered active data sourced from Radio0 set of registers

ASDIV – AD PAD Enabled (State1)

The AD pad defines the active set of registers for triggering. At each transition of the AD pad the corresponding set of DAC value registers are triggered.

Only the set of registers the AD pad is pointing to can be used to trigger an immediate update. In case of the SW trigger enable, only the registers AD pad is activating will be triggered. Therefore there is no possibility to trigger Radio0 and Radio1 set of registers at the same time.

The read back from Radio0 or Radio1 set of registers return only the triggered active register values. The source of the trigger could be either set, only the current active register is read back.

If any exit from this mode is requested, the active registers hold their state (unless the request is to transition into State2 or State3). The exit itself is not a source of trigger.

If the AD Pad value switches under low power mode, the state of the pad can't be detected until the part is active and the DACs are re-enabled. At this point, if its state is different than the state entering into low power mode, the trigger is applied.

ASDIV – Dual Radio over RFFE – Radio0 Trigger (State2)

The AD pad value is ignored in this mode of operation. The status register at address 0x0E reflects the current active set of Radio registers. In case of the low power mode, there could be a difference between this reading and the dual radio control register value, since the register would not be sampled until the part goes back to active mode.

The transition into this state triggers the Radio0 set of registers. If the register is updated as part of an extended register write, the trigger waits until the end of the frame. This way under the same frame the corresponding Radio0 registers can be updated and a trigger is requested.

The immediate update or SW triggering can still be utilized using the Radio0 set of registers.

The read back from the Radio0 or Radio1 addresses return the active register values triggered from the Radio0 source.

While in this mode the Radio1 registers can still be updated. This will not trigger anything.

The exit from this state itself is not a source of trigger.

If the transition into this state occurs during the low power mode, the trigger is applied as soon as the part is out of the low power mode and the DACs are re-enabled.

This Dual Radio triggering over the RFFE Interface has to respect the same timing as the SW triggering

ASDIV – Dual Radio over RFFE – Radio1 Trigger (State3)

The AD pad value is ignored in this mode of operation. The status register at address 0x0E reflects the current active set of Radio registers. In case of the low power mode, there could be a difference between this reading and the dual radio control register value, since the register would not be sampled until the part goes back to active mode.

The transition into this state triggers the Radio1 set of registers. If the register is updated as part of an extended register write, the trigger waits until the end of the frame. This way under the same frame the corresponding Radio1 registers can be updated and a trigger is requested.

The immediate update or SW triggering can still be utilized using the Radio1 set of registers.

The read back from the Radio0 or Radio1 addresses return the active register values triggered from the Radio1 source.

While in this mode the Radio0 registers can still be updated. This will not trigger anything.

The exit from this state itself is not a source of trigger.

If the transition into this state occurs during the low power mode, the trigger is applied as soon as the part is out of the low power mode and the internal oscillator has started.

The Dual Radio triggering over the RFFE Interface has to respect the same timing as the SW triggering.

ASDIV – Glide Handling

The glide operation under the dual radio triggering can be governed globally for all DACs using the Glide Control field of the RFFE_REG_0x0E. The intension is to help reducing the RFFE transactions necessary. In its default state of State0, the glide is purely controlled by the GL_X fields of the DAC value registers.

When the glide control is set to State1, after each dual radio triggering, the corresponding GL bit of the DAC target rffe register is cleared. This allows a “single shot” operation, where the GL_X bits in DAC target registers are considered as a single execution order.

If the dual radio triggering should not be resulting in any glide at all, the glide control can be set to State2. This is effectively a global mask to GL bits in dual radio triggering. The DAC rffe registers hold on to their GL values, the dual radio triggering ignores them.

If the dual radio triggering should always execute a glide in transitions, the glide control can be set to State3. In this case again the GL bits in the source rffe registers hold on to their values. The dual radio triggering enforces the glide bits to be set during the triggering.

DAC Update Triggering

The entire digital logic responsible for DAC updates is using the clock provided by the internal RC oscillator. In order to minimize the power consumption, the RC clock is set at a low frequency around 2 MHz.

DAC Writes

Figure 9 shows the diagram of the DAC data path, from the moment data is written into DACx_value register, until it is sent out to DAC.

After the DACx_value register is written using MIPI-RFFE clock, the data is copied on RC clock domain,

into the first data stage represented in Figure 9 as 'Completed'. The data is moved into 'New' and 'DAC-Out' stages by the DAC driver state machine, once the trigger is detected. The Turbo path also highlights the glide calculation.

If SW trigger is not enabled, then data will flow through the stages right after the corresponding DAC is updated, without waiting for a trigger (MIPI write is considered as the trigger).

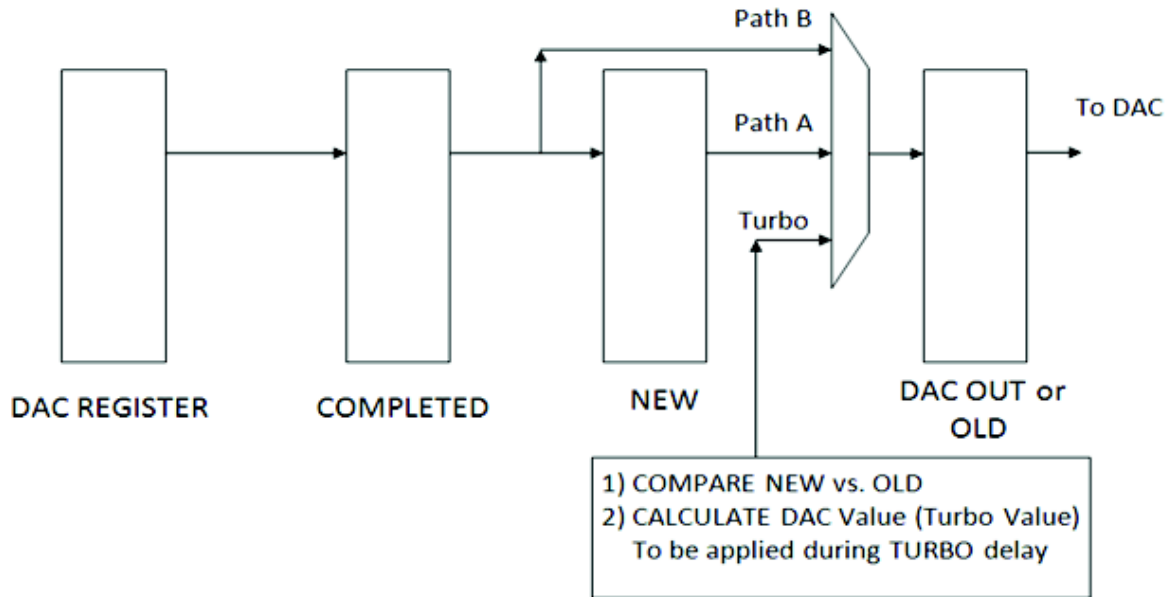

Figure 9. DACx Data Path

To bypass the SW trigger and enable an immediate trigger the Mask bits under the RFFE_PM_TRIG register should be set according to the USID control of the DAC. Trigger Mask 2 is controller with USID_2, Trigger Mask 1 is controlled with USID_1 and Trigger Mask 0 is controlled with USID_0. In MIPI-RFFE configuration, if RFFE_PM_TRIG / Trigger_Mask_2 = '1', and RFFE_PM_TRIG / Trigger_Mask_1 = '1' and RFFE_PM_TRIG / Trigger_Mask_0 = '1' (all software triggers are masked), then each DAC value is copied into 'Completed' stages of each DAC, after the messages RFFE_REG_0x06, RFFE_REG_0x07, RFFE_REG_0x08 or RFFE_REG_0x09 respectively are received, as shown in following sequence.

MIPI_RFFE_WRITE #1: send DAC_A_value and glide/turbo mode to RFFE_REG_0x06

MIPI_RFFE_WRITE #2: send DAC_B_value and glide/turbo mode to RFFE_REG_0x07

MIPI_RFFE_WRITE #3: send DAC_C_value and glide/turbo mode to RFFE_REG_0x08

MIPI_RFFE_WRITE #4: send DAC_D_value and glide/turbo mode to RFFE_REG_0x09

The individual writes above could be combined into a single extended write with all DACs controlled with the same USID or the DURs of the DACs are sitting at "11" configuration. Right after MIPI_RFFE_WRITE #1 to RFFE_REG_0x06, above, is received the DAC_A value register is copied in 'Completed' stage of DAC_A. The glide step, dac control or turbo control DO NOT need to be updated for each DAC update. But if they need to be, they can be updated as part of a full extended write or single write prior to the DAC value updates without any timing limitation. Since the SW trigger is masked, next RC clock cycle after DAC values are copied in 'Completed' stage, the data will move in next stages 'New' and 'DAC-Out' without waiting for any trigger.

The similar events occur for DAC_B, DAC_C and DAC_D after the MIPI_RFFE_WRITE #2 and MIPI_RFFE_WRITE #3.

Due to the fact that the MIPI-RFFE master can send DAC updates messages at a higher frequency, than RC clock, the data buffer 'Completed', can be overwritten if new DAC updates occur in the same time when the buffer is loaded.

While data and configuration are copied from DAC_x_value register into ‘Completed’ stage, the MIPI-RFFE master must not send any new DAC updates to DAC_x_value registers or configurations. The time required for the data to be copied from DAC_x_value register into ‘Completed’ stage is Max 1500 ns, which is defined by the three RC clock cycles required to synchronize data from MIPI-RFFE clock domain to RC clock domain.

In Figure 10, DAC_UPDATE_LAT represents the period when MIPI-RFFE master is not allowed to send any new DAC updates to DAC_x_value registers and DAC configuration registers.

The DAC enables (RFFE_REG_0x00) and Booster configurations (RFFE_REG_0x02) are applied immediately without waiting any trigger. These registers should be configured prior, so that the DAC updates are effective as fast as possible.

If there is already an ongoing DAC update and the Dual Radio control is changed, this is considered as a transition.

Even if the dual radio triggering occurs in lesser than DAC_UPDATE_LAT duration from the RFFE triggering, this is handled as a proper transition.

It takes approximately the same duration as an RFFE trigger to propagate the dual radio trigger

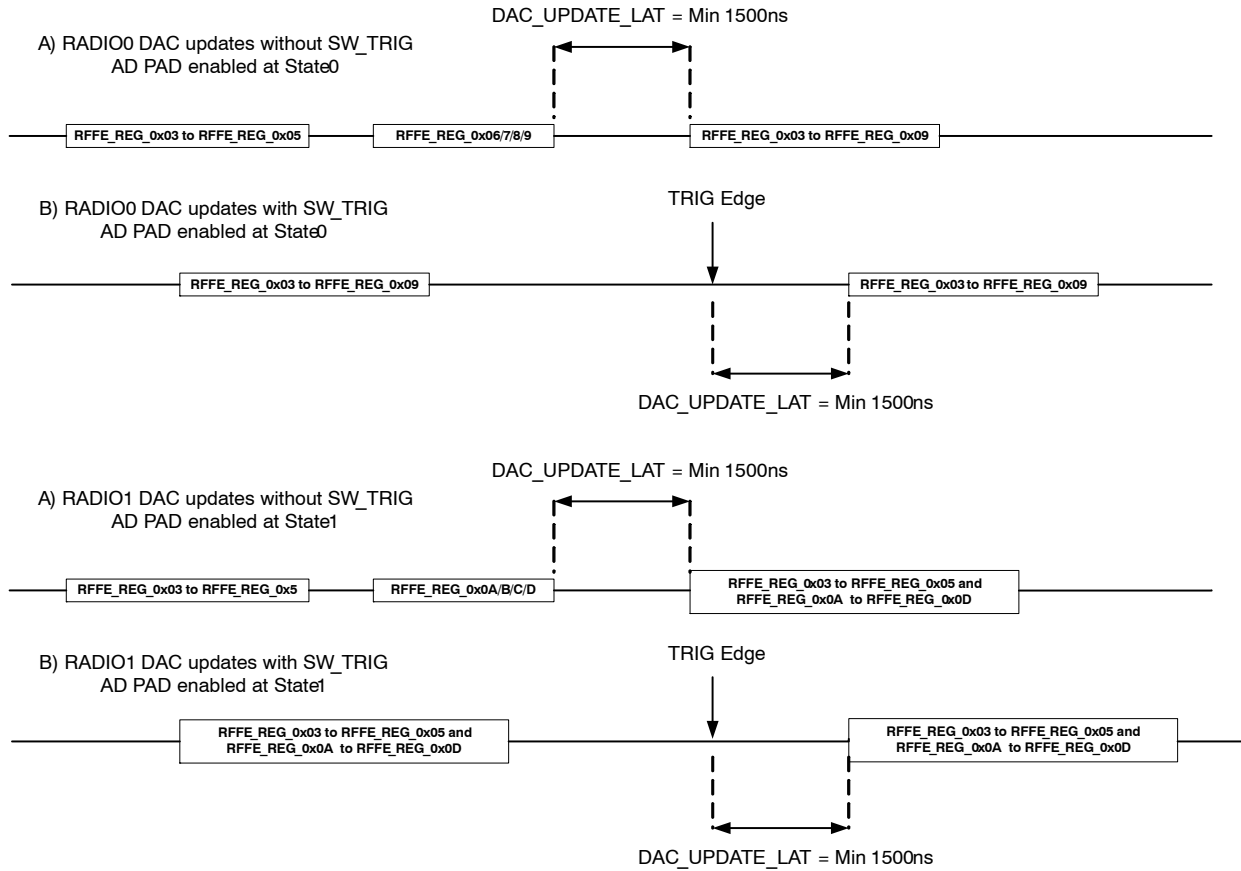

Figure 10. DAC_UPDATE_LAT Requirement

The SW trigger as well as immediate trigger can be configured in many combinations using the DUR settings of the DACs and the USID values. The SW trigger masks can only be changed with the write access using the slave address of their corresponding USID. But the corresponding triggers can be set by accesses over broadcast, with broadcast ID (0x0) or GSID.

The triggering and DAC register access is governed by these rules:

- The DUR configuration assigns a DAC to a USID. The corresponding DAC registers can only be accessed with USID defined by its DUR.

- The immediate update of this DAC is enabled if the SW trigger mask of the corresponding USID is set (disabled).
- The PM_TRIG register bit0 (SW trigger0) is masked by bit4 and assigned to DACs triggering, which are mapped to USID0 or all USIDs (the DAC DUR=0 or 3).
- The PM_TRIG register bit1 (SW trigger1) is masked by bit5 and assigned to DACs triggering, which are mapped to USID1 or all USIDs (the DAC DUR=1 or 3).
- The PM_TRIG register bit2 (SW trigger2) is masked by bit6 and assigned to DACs triggering, which are mapped to USID2 or all USIDs (the DAC DUR=2 or 3).

- For a DAC with DUR=3, all SW masks need to be set for that DAC to be triggered with direct access to its target register.

If all DACs are kept at DUR values of 3 and the USIDs are kept the same (reset condition), the part behaves according to the MIPI spec with single USID. If some of the USIDs are different while DUR=3, the part responds to the accesses with these different USIDs the same fashion.

If all USIDs are kept equal, the part functions with a single USID. But the DUR settings still control the SW trigger mapping for the DACs independent of the USID values. The DACs which are not holding a DUR value of 3 will be under the control of the SW trigger-mask duo mapped by their DUR setting.

In Table 11 some example register settings for listed functionality are provided. For the given functionality the

response of the part to DAC updates and SW triggers are tabulated. In this table the “DAC trigger” corresponds to a trigger happening at the time of the DAC value update. The “SW trigger” corresponds to a trigger happening with the PM_TRIG register write. At this point, it is assumed that the DACs are enabled and the new DAC value is not matching to the existing pre-triggered DAC value in the active register. Some of the abbreviations utilized in the table are:

TRG = successful trigger of the new targets

HLD = no trigger, hold on to existing DAC drives

WR = The new DAC values are captured into RFFE shadow registers

NW = The RFFE write to shadow registers are blocked, no register update.

Table 11. IMMEDIATE vs SOFTWARE TRIGGERING USING USIDs and DURs

FUNCTIONALITY & EXAMPLE REGISTER VALUES	DACA WR ID0	DACA WR ID1	DACA WR ID2	DACA WR Broad	Trigger 3b111 ID0	Trigger 3b111 ID1	Trigger 3b111 ID2	Trigger 3b111 Broad	Trigger 3b001 Broad	Trigger 3b010 Broad	Trigger 3b100 Broad	Comments
(DEFAULT) DAC TRIGGER – SINGLE USID – DUR=3 DUR_A = 3 (USIDx, TRGx) SW_TRG Mask = 3'b111 USID0,1,2 = 4b0111	TRG (WR)	TRG (WR)	TRG (WR)	HLD (NW)	HLD	HLD	HLD	HLD	HLD	HLD	HLD	All USIDs are the same. All SW triggers are masked. The USID DAC writes trigger immediately.
SW TRIGGER – SINGLE USID – DUR =3 DUR_A = 3 (USIDx, TRGx) SW_TRG Mask = 3'b101 USID0,1,2 = 4b0111	HLD (WR)	HLD (WR)	HLD (WR)	HLD (NW)	TRG	TRG	TRG	TRG	HLD	TRG	HLD	All USIDs are the same. Only trigger 1 is enabled. This enables the SW trigger since DUR=3, mapping the DAC to all triggers
DAC TRIGGER – SINGLE USID – DUR=0 DUR_A = 0 (USID0, TRG0) SW_TRG Mask = 3'b101 USID0,1,2 = 4b0111	TRG (WR)	TRG (WR)	TRG (WR)	HLD (NW)	HLD	HLD	HLD	HLD	HLD	HLD	HLD	All USIDs are the same. Only trigger 1 is enabled. The DUR of the DAC is mapping it to trigger 0 (masked). Therefore SW trigger is disabled.
SW TRIGGER – SINGLE USID – DUR =1 DUR_A = 1 (USID1, TRG1) SW_TRG Mask = 3'b101 USID0,1,2 = 4b0111	HLD (WR)	HLD (WR)	HLD (WR)	HLD (NW)	TRG	TRG	TRG	TRG	HLD	TRG	HLD	All USID's are the same. Only trigger 1 is enabled. The DUR of the DAC is mapping it to trigger 1 (enabled). Therefore SW trigger is enabled.
DAC TRIGGER – (1,2) USIDs – DUR=2 DUR_A = 2 (USID2, TRG2) SW_TRG Mask = 3'b100 USID0,1 = 4b0111, USID2 = 4b1000	HLD (NW)	HLD (NW)	TRG (WR)	HLD (NW)	HLD	HLD	HLD	HLD	HLD	HLD	HLD	USID2 is different, only USID2 dac access is allowed and the DAC triggers immediately, since the SW trigger mask is set.
SW TRIGGER – (1,2) USIDs – DUR =2 DUR_A = 2 (USID2, TRG2) SW_TRG Mask = 3'b000 USID0,1 = 4b0111, USID2 = 4b1000	HLD (NW)	HLD (NW)	HLD (WR)	HLD (NW)	HLD	HLD	TRG	TRG	HLD	HLD	TRG	USID2 is different, only USID2 dac access is allowed. Trigger 2 is unmasked, SW trigger is enabled. Only trigger 2 is active for USID2.
DAC TRIGGER – (2,1) USIDs – DUR = 1 DUR_A = 1 (USID1, TRG1) SW_TRG Mask = 3'b110 USID0,1 = 4b0111, USID2 = 4b1000	TRG (WR)	TRG (WR)	HLD (NW)	HLD (NW)	HLD	HLD	HLD	HLD	HLD	HLD	HLD	Since USID0 = USID1 both USID0, USID1 DAC target writes are allowed. SW trigger1 masked; SW triggering disabled
SW TRIGGER – (2,1) USIDs –DUR = 1 DUR_A = 1 (USID1, TRG1) SW_TRG Mask = 3'b100 USID0,1 = 4b0111, USID2 = 4b1000	HLD (WR)	HLD (WR)	HLD (NW)	HLD (NW)	TRG	TRG	HLD	TRG	HLD	TRG	HLD	Same as above but SW trigger 1 is enabled; SW triggering enabled. USID0, USID1 are the same but the DAC is mapped to Trg1 only. Trg0 alone does not trigger.
DAC TRIGGER – (1,1,1) USIDs – DUR = 0 DUR_A = 0 (USID0, TRG0) SW_TRG Mask = 3'b001 USID0 = 4b0111, USID1 = 4b1000, USID2 = 4b1001	TRG (WR)	HLD (NW)	HLD (NW)	HLD (NW)	HLD	HLD	HLD	HLD	HLD	HLD	HLD	The DAC is mapped to USID0 and the corresponding trigger is masked. It triggers immediately at DAC update with USID0
SW TRIGGER – (1,1,1) USIDs – DUR = 0 DUR_A = 0 (USID0, TRG0) SW_TRG Mask = 3'b000 USID0 = 4b0111, USID1 = 4b1000, USID2 = 4b1001	HLD (WR)	HLD (NW)	HLD (NW)	HLD (NW)	TRG	HLD	HLD	TRG	TRG	HLD	HLD	The DAC is mapped to USID0 and the TRG0 is enabled. It triggers only at TRG0 with USID0 or Broadcast access

MIPI RFFE Interface

TCC-404 is a slave device and is compliant to the MIPI Alliance Specification for RF Front-End Control Interface (RFFE) Version 2.0 excluding the interrupt support, extended long R/W, double byte product ID and dual GSID.

Following MIPI RFFE commands are supported:

1. Register 0 WRITE
2. Register WRITE
3. Register READ
4. Extended Register WRITE
5. Extended Register READ

Registers 0x00 to 0x3F are available to be read/written. The writes in extended speed frequency and reads in standard speed frequency are supported. The slew rate on the read access can be configured by the SDATA Pad Slew bit. This can reduce EMI in expense of longer read delay.

The extended register write long and read long commands are not supported. If an extended register write long command is received, no register is written and the RFFE_STATUS.WURE flag is set. If an extended register read long command is received, the part responds with bus idle and the RFFE_STATUS.RURE flag is set.

The read access to registers RFFE_REG_0x03 to RFFE_REG_0x0D returns the active register content, which is the register updated after a trigger. The pre-trigger shadow register does not have read access.

Some registers are exact remapping to meet the RFFE 2.0 register mapping. The GSID is mapped to both address 0x1B and 0x22. The UDR_RST is mapped to both address 0x1A and 0x23. The ERR_SUM is mapped to both address 0x24 and 0x1A.

Table 12. MIPI RFFE INTERFACE SPECIFICATION

($T_A = -30$ to $+85^\circ\text{C}$; $2.3\text{ V} < V_{DDA} < 5.5\text{ V}$; $1.1\text{ V} < V_{IO} < 1.8\text{ V}$; unless otherwise specified)

Parameter	Description	Min	Typ	Max	Unit	Comments
F _{SCLK_EXT}	Clock Extended Speed Frequency	0.032	-	52	MHz	Extended Speed Operation: 1.65 V < V _{IO} < 1.95 V
T _{SCLK_EXT}	Clock Extended Speed Period	0.0192	-	32	μs	Extended Speed Operation: 1.65 V < V _{IO} < 1.95 V
T _{SCLKIH_EXT}	CLK Input Extended High Time	6.0	-	-	ns	Extended Speed
T _{SCLKIL_EXT}	CLK Input Extended Low Time	6.0	-	-	ns	Extended Speed
F _{SCLK_STD}	Clock Standard Speed Frequency	0.032	-	26	MHz	Standard Speed Operation: 1.65 V < V _{IO} < 1.95 V
T _{SCLK_STD}	Clock Standard Speed Period	0.038	-	32	μs	Standard Speed Operation: 1.65 V < V _{IO} < 1.95 V
T _{SCLKIH_STD}	CLK Input Standard High Time	11.25	-	-	ns	Standard Speed
T _{SCLKIL_STD}	CLK Input Standard Low Time	11.25	-	-	ns	Standard Speed
V _{TP}	Positive Going Threshold Voltage	0.4 x V _{IO}	-	0.7 x V _{IO}	V	CLK, DATA, 1.8 V Bus
V _{TN}	Negative Going Threshold Voltage	0.3 x V _{IO}	-	0.6 x V _{IO}	V	CLK, DATA, 1.8 V Bus
V _H	Hysteresis Voltage (V _{TP} - V _{TN})	0.1 x V _{IO}	-	0.4 x V _{IO}	V	CLK, DATA, 1.8 V Bus
I _{IH}	Input Current High	-2	-	+10	μA	SDATA = 0.8 x V _{IO}
		-1	-	+10	μA	SCLK = 0.8 x V _{IO}
I _{IL}	Input Current Low	-2	-	+1	μA	SDATA = 0.2 x V _{IO}
		-1	-	+1	μA	SCLK = 0.2 x V _{IO}
C _{CLK}	Input Capacitance	-	-	2.2	pF	CLK Pin
C _{DATA}	Input Capacitance	-	-	2.5	pF	DATA Pin
TD _{SETUP}	Write DATA Setup Time	-	-	1	ns	Extended Speed
TD _{HOLD}	Write DATA Hold Time	-	-	5	ns	Extended Speed
T _{READ_ACCESS}	Read DATA valid from CLK rising edge	-	-	4.0	ns	V _{IO} = 1.80 V, +25°C, and max 15 pF load on DATA pin. SDATA Pad Slew = 1.
T _{READ_ACCESS}	Read DATA valid from CLK rising edge	-	-	1.93	ns	V _{IO} = 1.80 V, +25°C, and max 15 pF load on DATA pin. SDATA Pad Slew = 0.

Table 12. MIPI RFFE INTERFACE SPECIFICATION (continued)
 ($T_A = -30$ to $+85^\circ\text{C}$; $2.3\text{ V} < V_{DDA} < 5.5\text{ V}$; $1.1\text{ V} < V_{IO} < 1.8\text{ V}$; unless otherwise specified)

Parameter	Description	Min	Typ	Max	Unit	Comments
$T_{\text{READ_ACCESS}}$	Read DATA valid from CLK rising edge	-	-	8.0	ns	$V_{IO} = 1.80\text{ V}$, $+25^\circ\text{C}$, and max 60 pF load on DATA pin. SDATA Pad Slew = 1.
$T_{\text{READ_ACCESS}}$	Read DATA valid from CLK rising edge	-	-	3.81	ns	$V_{IO} = 1.80\text{ V}$, $+25^\circ\text{C}$, and max 60 pF load on DATA pin. SDATA Pad Slew = 0.

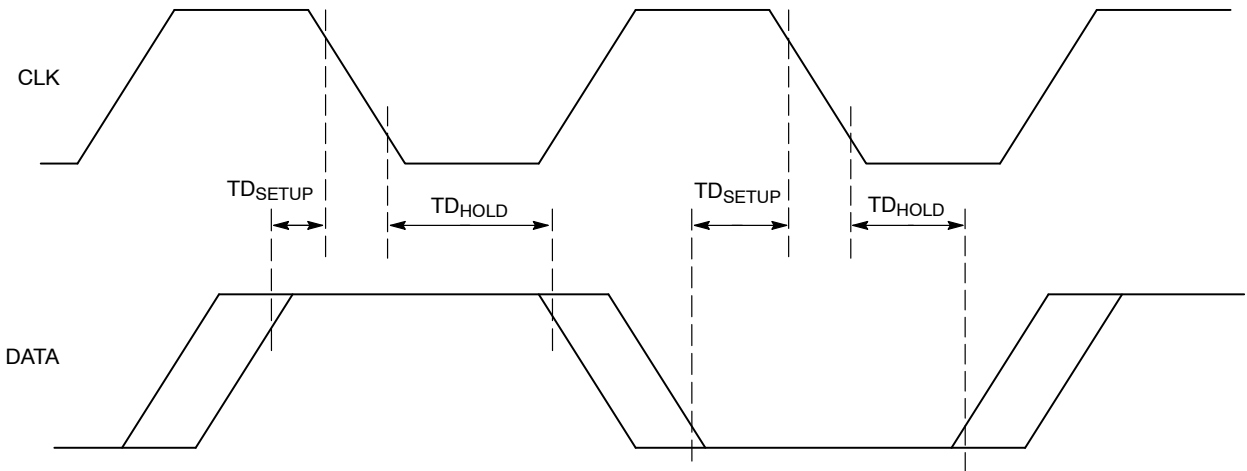

Figure 11. MIPI-RFFE Signal Timing during Master Writes to PTIC Control IC

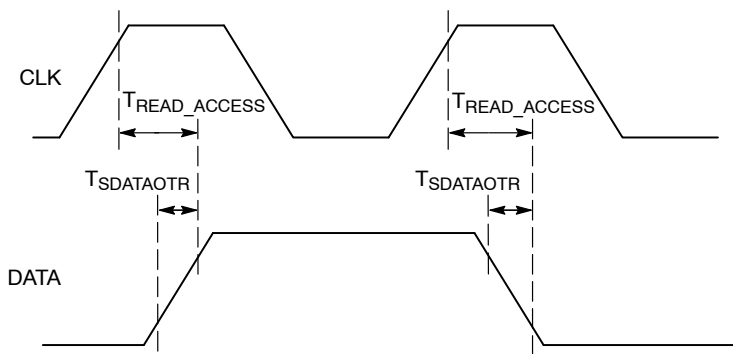

Figure 12. MIPI-RFFE Signal Timing during Master Reads from PTIC Control IC

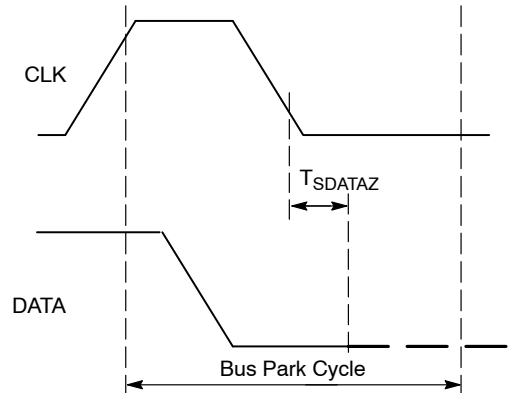

Figure 13. Bus Park Cycle Timing when MIPI-RFFE Master Reads from PTIC Control IC

TCC-404

The control IC contains eighteen 8-bit registers. Register content is described in Table 13. Some additional registers implemented as provision, are not described in this document.

Table 13. MIPI RFFE ADDRESS MAP

Address	Description	USID	Purpose	Access	Size [bits]
0x00	RFFE_REG_0x00	All	DAC enables, Extended Write/Read Control, DATA pad slew	R/W RegWrite0	7
0x01	RFFE_REG_0x01	All	DUR for DAC_A/_B/_C/_D	R/W	8
0x02	RFFE_REG_0x02	All	Booster settings	R/W	8
0x03	RFFE_REG_0x03	All	Glide settings	R/W	8
0x04	RFFE_REG_0x04	All	Autonomous Turbo Settings	R/W	8
0x05	RFFE_REG_0x05	All	DACs Control	R/W	8
0x06	RFFE_REG_0x06	DUR_A	DAC_A Value Radio0	R/W	8
0x07	RFFE_REG_0x07	DUR_B	DAC_B Value Radio0	R/W	8
0x08	RFFE_REG_0x08	DUR_C	DAC_C Value Radio0	R/W	8
0x09	RFFE_REG_0x09	DUR_D	DAC_D Value Radio0	R/W	8
0x0A	RFFE_REG_0x0A	DUR_A	DAC_A Value Radio1	R/W	8
0x0B	RFFE_REG_0x0B	DUR_B	DAC_B Value Radio1	R/W	8
0x0C	RFFE_REG_0x0C	DUR_C	DAC_C Value Radio1	R/W	8
0x0D	RFFE_REG_0x0D	DUR_D	DAC_D Value Radio1	R/W	8
0x0E	RFFE_REG_0x0E	All	Dual Radio Control	R/W	8
0x0F to 0x17	SPARE	N/A	Spare for future product development		
0x18	USID_1	USID_1 & Broadcast	Spare [7:6] [5,4] = Manufacturer ID [9:8] USID_1 [3:0]	R/W	8
0x19	USID_2	USID_2 & Broadcast	Spare [7:6] [5,4] = Manufacturer ID [9:8] USID_2 [3:0]	R/W	8
0x1A	RFFE_STATUS	All	RFFE status register	R/W	8
0x1B	RFFE_GROUP_SID	All	The Group Broadcast ID	R/W	8
0x1C	RFFE_PM_TRIG	All & Broadcast	Power Mode & Trigger Control PWR_MODE [7:6] TRIG_REG [5:0]	R/W	8
0x1D	PID_0, default	All	MIPI Product ID (Note 2)	R	8
0x1E	Manufacturer ID Register	All	MN (10bits long) Manufacturer ID[7:0] (Note 2)	R	8
0x1F	USID_0, default	USID_0 & Broadcast	Spare [7:6] [5,4] = Manufacturer ID [9:8] (Note 3) USID [3:0]	R/W	8
0x20 to 0x21	RFFE 2.0 RESERVED	N/A	Unsupported fields in TCC404 defined by RFFE 2.0		
0x22	RFFE_GROUP_SID_EXT	All	The Group Broadcast ID	R/W	8
0x23	UDR_RST	All	User defined registers software reset	R/W	8
0x24	ERR_SUM	All	User-defined Error Logging	R	8
0x25 to 0x2B	RFFE 2.0 RESERVED	N/A	Unsupported fields in TCC404 defined by RFFE 2.0		

Table 13. MIPI RFFE ADDRESS MAP (continued)

Address	Description	USID	Purpose	Access	Size [bits]
0x2C	TEST_PATT	All	Slave Fixed Test Pattern	R	8
0x2D to 0x3F	RFFE 2.0 RESERVED	N/A	Unsupported fields in TCC404 defined by RFFE 2.0		

2. The least significant bits from the Product ID register are refined by OTP. The other seven bits of product ID are hardcoded in ASIC.
3. The manufacturer ID is hardcoded in ASIC, mapped in a READ-only register.

Register Content Details

Register RFFE:	RFFE_REG_0x00	Address RFFE A[4:0]:	[0x00]
----------------	---------------	----------------------	--------

Reset Source: nreset_dig or SWR = ‘1’ or PWR_MODE = ‘01’ (transition through STARTUP mode)

	7	6	5	4	3	2	1	0
Bits	N/A	spare	SDATA Pad Slew	Extended DAC Jump	DAC D en	DAC C en	DAC B en	DAC A en
Reset	U-0	U-0	W-0	W-0	W-0	W-0	W-0	W-0

Bit [3:0] Each DAC is enabled when the corresponding bit is set. The enable or disable occurs immediately without waiting for a trigger. 0: Off (default) 1: enabled

Bit [4]: In extended write or read jump the address increment over the DACs, which are not intended to be accessed based on the USID of the frame and the DUR configuration of the corresponding DAC. If the access starts intentionally from one of these registers, the address for the first access can’t jump. The consecutive increments take into account the state of the DUR and access USID. The addresses with the “All” notation are never skipped

Bit [5]: The Sdata slew can be controlled with this bit. When there isn’t a high load on the RFFE interface, to reduce the EMI, this bit can be set to increase the slew on the DATA toggling. It will only impact the EMI during the read from tcc404. If the load on the line is very high and the read timing could be jeopardized, the slew bit should be kept low.

Bit [7]: Register 0 write command excludes this bit. The extended writes to this address ignores bit 7. The bit is not utilized

TCC-404

Register RFFE:	RFFE_REG_0x01	Address RFFE A[4:0]:	0x01
----------------	---------------	----------------------	------

Reset Source: nreset_dig or SWR = '1' or PWR_MODE = 'X1' (transition through STARTUP mode)

	7	6	5	4	3	2	1	0
Bits	DUR_D [1:0]		DUR_C [1:0]		DUR_B [1:0]		DUR_A [1:0]	
Reset	W-1	W-1	W-1	W-1	W-1	W-1	W-1	W-1

DUR_x [1:0] (DAC x USID response)

'00': Responds only to USID_0 in DAC register write. SW trigger0 mask defines the triggering source.

'01': Responds only to USID_1 in DAC register write. SW trigger1 mask defines the triggering source.

'10': Responds only to USID_2 in DAC register write. SW trigger2 mask defines the triggering source.

'11': Responds to any 3 USID in DAC register write. Any trigger mask cleared enables the SW triggering.

Register RFFE:	RFFE_REG_0x02	Address RFFE A[4:0]:	0x02
----------------	---------------	----------------------	------

Reset Source: nreset_dig or SWR = '1' or PWR_MODE = 'X1' (transition through STARTUP mode)

	7	6	5	4	3	2	1	0
Bits	Reserved	boost_pwm_en	Reserved	boost_en	Boost voltage value			
Reset	U-0	W-1	U-0	W-1	W-1	W-1	W-0	W-1

Bit [6]: Enables the boost oscillator pwm function. This signal should be turned off in case the booster generates low voltages to reduce the ripple.

Bit [4]: Enable/disable of the booster. Booster must be turned off when the high voltage is provided externally.

Bit [3:0]: **Boost voltage value.** Refer to Table 14 for values

Table 14. BOOST VOLTAGE SETTING

Boost Voltage Value[3:0]	VHV [V]	Note	Boost Voltage Value[3:0]	VHV [V]	Note
0000	15	Target values	1000	23	Target values
0001	16		1001	24	
0010	17		1010	25	
0011	18		1011	26	
0100	19		1100	27	
0101	20		1101	28 (default)	
0110	21		1110	29	
0111	22		1111	30	

Register RFFE:	RFFE_REG_0x03	Address RFFE A[4:0]:	0x03
----------------	---------------	----------------------	------

Reset Source: nreset_dig or SWR = '1' or PWR_MODE = 'X1' (transition through STARTUP mode)

	7	6	5	4	3	2	1	0
Bits	Reserved			GLIDE TIMER STEP SIZE				
Reset	U-0	U-0	U-0	W-0	W-1	W-1	W-1	W-1

Bit [4:0] For the definition of the glide timer step size field, see Table 10.

NOTE: The read access to this register will return the active content post-trigger, not the shadow register.

TCC-404

Register RFFE:	RFFE_REG_0x04	Address RFFE A[4:0]:	0x04
----------------	---------------	----------------------	------

Reset Source: nreset_dig or SWR = '1' or PWR_MODE = 'X1' (transition through STARTUP mode)

	7	6	5	4	3	2	1	0
Bits	TurboUpMultiplier			TurboDownMultiplier			TurboDownFactor	
Reset	W-0	W-0	W-0	W-0	W-1	W-1	W-1	W-1

Bit [7:5]: The Turbo-Up Multiplier. The autonomous Turbo Up time calculated is multiplied with this factor and reloaded into Turbo Timer at the last stage of the Turbo. Effectively the Turbo time calculation is multiplied by a factor of 1.x. The decoding is as below:

- '000': The autonomous turbo up time is applied with a factor of 1.0
- '001': The autonomous turbo up time is applied with a factor of 1.125
- '010': The autonomous turbo up time is applied with a factor of 1.25
- '011': The autonomous turbo up time is applied with a factor of 1.375
- '100': The autonomous turbo up time is applied with a factor of 1.5
- '101': The autonomous turbo up time is applied with a factor of 1.625
- '110': The autonomous turbo up time is applied with a factor of 1.75
- '111': The autonomous turbo up time is applied with a factor of 1.875

Bit [4:2]: The Turbo-Down Multiplier. The autonomous Turbo Down time calculated is multiplied with this factor and reloaded into Turbo Timer at the last stage of the Turbo. Effectively the Turbo time calculation is multiplied by a factor of 1.x. The decoding is as below:

- '000': The autonomous turbo down time is applied with a factor of 1.0
- '001': The autonomous turbo down time is applied with a factor of 1.125
- '010': The autonomous turbo down time is applied with a factor of 1.25
- '011': The autonomous turbo down time is applied with a factor of 1.375
- '100': The autonomous turbo down time is applied with a factor of 1.5
- '101': The autonomous turbo down time is applied with a factor of 1.625
- '110': The autonomous turbo down time is applied with a factor of 1.75
- '111': The autonomous turbo down time is applied with a factor of 1.875

Bit [1:0]: The Turbo-Down Factor. The autonomous Turbo Down time calculation is adjusted further with these two bits if the Turbo Down is active with a target voltage below 4V. The adjustment is done prior to the Turbo-Down Multiplier being applied

NOTE: The read access to this register will return the active content post-trigger, not the shadow register.

Register RFFE:	RFFE_REG_0x05	Address RFFE A[4:0]:	0x05
----------------	---------------	----------------------	------

Reset Source: nreset_dig or SWR = '1' or PWR_MODE = 'X1' (transition through STARTUP mode)

	7	6	5	4	3	2	1	0
Bits	DACD Control		DACC Control		DACB Control		DACA Control	
Reset	W-0	W-0	W-0	W-0	W-0	W-0	W-0	W-0

DACx Control :

- '00': Auto Turbo Mode enabled with 189mV DAC steps, reaching to 28V with +/- 4V delta control
- '01': Auto Turbo Mode enabled with 220mV DAC steps, reaching to Booster level with +4V delta
- '10': Turbo Mode disabled, normal update activated with 189mV DAC steps reaching to 24V
- '11': Turbo Mode disabled, normal update activated with 220 mV DAC steps reaching to 28V

NOTE: The read access to this register will return the active content post-trigger, not the shadow register.

Register RFFE:	RFFE_REG_0x06	Address RFFE A[4:0]:	0x06
----------------	---------------	----------------------	------

Reset Source: nreset_dig or SWR = '1' or PWR_MODE = 'X1' (transition through STARTUP mode)

	7	6	5	4	3	2	1	0
Bits	GL_A Radio0	DAC A value [6:0]						
Reset	W-0	W-0	W-0	W-0	W-0	W-0	W-0	W-0

Bit [7] If the GL_A=1, the update is done with glide. If GL_A =0 and the DACA Turbo/Norm is zero, Turbo is started with the new DAC A value.

NOTE: The read access to this register will return the active content post-trigger, not the shadow register. The DAC value read-back is not the actual analog drive, it is the target level.

TCC-404

Register RFFE:	RFFE_REG_0x07	Address RFFE A[4:0]:	0x07
----------------	---------------	----------------------	------

Reset Source: nreset_dig or SWR = '1' or PWR_MODE = '01' (transition through STARTUP mode)

	7	6	5	4	3	2	1	0
Bits	GL_B Radio0	DAC B value [6:0]						
Reset	W-0	W-0	W-0	W-0	W-0	W-0	W-0	W-0

Bit [7] If the GL_B=1, the update is done with glide. If GL_B =0 and the DACB Turbo/Norm is zero, Turbo is started with the new DAC B value.

NOTE: The read access to this register will return the active content post-trigger, not the shadow register. The DAC value read-back is not the actual analog drive, it is the target level.

TCC-404

Register RFFE:	RFFE_REG_0x08	Address RFFE A[4:0]:	0x08
----------------	---------------	----------------------	------

Reset Source: nreset_dig or SWR = '1' or PWR_MODE = 'X1' (transition through STARTUP mode)

	7	6	5	4	3	2	1	0
Bits	GL_C Radio0	DAC C value [6:0]						
Reset	W-0	W-0	W-0	W-0	W-0	W-0	W-0	W-0

Bit [7] If the GL_C=1, the update is done with glide. If GL_C =0 and the DACC Turbo/Norm is zero, Turbo is started with the new DAC C value.

NOTE: The read access to this register will return the active content post-trigger, not the shadow register. The DAC value read-back is not the actual analog drive, it is the target level.

Register RFFE:	RFFE_REG_0x09	Address RFFE A[4:0]:	0x09
----------------	---------------	----------------------	------

Reset Source: nreset_dig or SWR = '1' or PWR_MODE = 'X1' (transition through STARTUP mode)

	7	6	5	4	3	2	1	0
Bits	GL_D Radio0	DAC D value Radio0 [6:0]						
Reset	W-0	W-0	W-0	W-0	W-0	W-0	W-0	W-0

Bit [7] If the GL_D=1, the update is done with glide. If GL_D =0 and the DACD Turbo/Norm is zero, Turbo is started with the new DAC D value.

NOTE: The read access to this register will return the active content post-trigger, not the shadow register. The DAC value read-back is not the actual analog drive, it is the target level.

Register RFFE:	RFFE_REG_0x0A	Address RFFE A[4:0]:	0x0A
----------------	---------------	----------------------	------

Reset Source: nreset_dig or SWR = '1' or PWR_MODE = 'X1' (transition through STARTUP mode)

	7	6	5	4	3	2	1	0
Bits	GL_A Radio1	DAC A value Radio1 [6:0]						
Reset	W-0	W-0	W-0	W-0	W-0	W-0	W-0	W-0

Bit [7] If the GL_A=1, the update is done with glide. If GL_A =0 and the DACA Turbo/Norm is zero, Turbo is started with the new DAC A value.

NOTE: The read access to this register will return the active content post-trigger, not the shadow register. The DAC value read-back is not the actual analog drive, it is the target level.

Register RFFE:	RFFE_REG_0x0B	Address RFFE A[4:0]:	0x0B
----------------	---------------	----------------------	------

Reset Source: nreset_dig or SWR = '1' or PWR_MODE = 'X1' (transition through STARTUP mode)

	7	6	5	4	3	2	1	0
Bits	GL_B Radio1	DAC B value Radio1 [6:0]						
Reset	W-0	W-0	W-0	W-0	W-0	W-0	W-0	W-0

Bit [7] If the GL_B=1, the update is done with glide. If GL_B =0 and the DACB Turbo/Norm is zero, Turbo is started with the new DAC B value.

NOTE: The read access to this register will return the active content post-trigger, not the shadow register. The DAC value read-back is not the actual analog drive, it is the target level.

Register RFFE:	RFFE_REG_0x0C	Address RFFE A[4:0]:	0x0C
----------------	---------------	----------------------	------

Reset Source: nreset_dig or SWR = '1' or PWR_MODE = 'X1' (transition through STARTUP mode)

	7	6	5	4	3	2	1	0
Bits	GL_C Radio1	DAC C value Radio1 [6:0]						
Reset	W-0	W-0	W-0	W-0	W-0	W-0	W-0	W-0

Bit [7] If the GL_C=1, the update is done with glide. If GL_C =0 and the DACC Turbo/Norm is zero, Turbo is started with the new DAC C value.

NOTE: The read access to this register will return the active content post-trigger, not the shadow register. The DAC value read-back is not the actual analog drive, it is the target level.

TCC-404

Register RFFE:	RFFE_REG_0x0D	Address RFFE A[4:0]:	0x0D
----------------	---------------	----------------------	------

Reset Source: nreset_dig or SWR = '1' or PWR_MODE = 'X1' (transition through STARTUP mode)

	7	6	5	4	3	2	1	0
Bits	GL_D Radio1	DAC D value Radio1 [6:0]						
Reset	W-0	W-0	W-0	W-0	W-0	W-0	W-0	W-0

Bit [7] If the GL_D=1, the update is done with glide. If GL_D =0 and the DACD Turbo/Norm is zero, Turbo is started with the new DAC D value.

NOTE: The read access to this register will return the active content post-trigger, not the shadow register. The DAC value read-back is not the actual analog drive, it is the target level.

Register RFFE:	RFFE_REG_0x0E	Address RFFE A[4:0]:	0x0E
----------------	---------------	----------------------	------

Reset Source: nreset_dig or SWR = '1' or PWR_MODE = 'X1' (transition through STARTUP mode)

	7	6	5	4	3	2	1	0
Bits	Reserved			AD State	Glide Control		Dual Radio Control	
Reset	U-0	U-0	U-0	R-0	W-0	W-0	W-0	W-0

Bit [4]: This bit field is used to read back the state of the active dual radio mode control. It shows whether the Radio0 or Radio1 set of registers are active. If the dual radio operation is disabled, the AD pad value is captured and it is not used internally for any control.

Bit [3:2]: These bits provide global glide control under the dual radio triggering. They don't change the glide operation under the conventional triggering (SW or immediate). The glide control is active in both AD pad and Dual Radio rffe control triggering.

'00': Standard (Default): The glide is active, only if the corresponding target Radio DAC register GL bit is set. The GL bit holds its value after the trigger. Therefore glide is used consecutively as long as GL is set.

'01': Single Shot: After any trigger the corresponding GL bit in the DAC rffe register is cleared. Therefore the glide is executed only once. This avoids the need to clear the GL bit in each DAC register.

'10': Glide Masked: Independent of the GL configurations in DAC registers, the dual radio triggering results in Turbo or Normal update. The GL bits in DAC registers are ignored, "0" values enforced at triggering. The DAC rffe registers hold their values. This is effectively a global mask to the GL bits.

'11': Glide Enforced: Independent of the GL configurations in DAC rffe registers, the dual radio triggering results in glide transition. The GL bits in DAC registers are ignored, "1" values enforced at triggering. The DAC shadow registers hold their values. This is effectively a global overdrive on GL bits.

Bit [1:0]: These fields control the dual radio operation; enabling the operation as well as selecting the active set of DAC registers if the AD pad is not utilized.

'00': The AD pad is disabled. There is no toggling between the Radio0 and Radio1 Registers. The Radio0 DAC registers are used as the active shadow registers.

'01': The AD pad is enabled. The Radio0 register set is triggered when the pad input transitions into "0" from "1". The Radio1 register set is triggered when the pad input transitions into "1" from "0". The pad defines which set of shadow registers are active for all triggering purposes.

'10': The AD pad is disabled. The Radio0 DAC registers are triggered in any transition into this dual radio control value. The Radio0 set of registers are active. A SW trigger or immediate update captures these Radio0 shadow content into active registers.

'11': The AD pad is disabled. The Radio1 DAC registers are triggered in any transition into this dual radio control value. The Radio1 set of registers are active. A SW trigger or immediate update captures these Radio1 shadow content into active registers.

NOTE: The read back value from the fields [3:0] is the RFFE configuration content. These controls are not triggered into a secondary register, since they control the actual triggering.

TCC-404

Register RFFE:	RFFE_USID_1	Address RFFE A[4:0]:	0x18
----------------	-------------	----------------------	------

Reset Source: nreset_dig or SWR = '1' or PWR_MODE = 'X1' (transition through STARTUP mode)

	7	6	5	4	3	2	1	0
Bits	Reserved (2)		MPN9 (2)	MPN8 (2)	USID3 (1)	USID2 (1)	USID1 (1)	USID0 (1)
Reset	U-0	U-0	0	1	W-0	W-1	W-1	W-1

USID = Unique Slave Identifier Register

1. USID field can be changed by:

- ◆ MIPI-RFFE broadcast messages when USID field within the Register Write Command is 0b0000
- ◆ MIPI-RFFE individual messages when USID field within the Register Write Command equal with content of RFFE_REG_0x18[3:0]

2. In the sequence of writing USID field, the upper [7:4] must match the value 0b0001 hardcoded in the RFFE register 0x18

NOTE: USID_1 value is NOT retained during SHUTDOWN power mode.

Register RFFE:	RFFE_USID_2	Address RFFE A[4:0]:	0x19
----------------	-------------	----------------------	------

Reset Source: nreset_dig or SWR = '1' or PWR_MODE = 'X1' (transition through STARTUP mode)

	7	6	5	4	3	2	1	0
Bits	Reserved (2)		MPN9 (2)	MPN8 (2)	USID3 (1)	USID2 (1)	USID1 (1)	USID0 (1)
Reset	0	0	0	1	W-0	W-1	W-1	W-1

USID = Unique Slave Identifier Register

1. USID field can be changed by:

- ◆ MIPI-RFFE broadcast messages when USID field within the Register Write Command is 0b0000
- ◆ MIPI-RFFE individual messages when USID field within the Register Write Command equal with content of RFFE_REG_0x19[3:0]

2. In the sequence of writing USID field, the upper [7:4] must match the value 0b0001 hardcoded in the RFFE register 0x19

NOTE: USID_2 value is NOT retained during SHUTDOWN power mode.

TCC-404

Register RFFE:	RFFE_STATUS	Address RFFE A[4:0]:	0x1A
----------------	-------------	----------------------	------

Reset Source: nreset_dig or SWR = '1' or PWR_MODE = 'X1' (transition through STARTUP mode)

	7	6	5	4	3	2	1	0
Bits	SWR	CFPE	CLE	AFPE	DFPE	RURE	WURE	BGE
Reset	W-0	R-0	R-0	R-0	R-0	R-0	R-0	R-0

SWR Soft-Reset MIPI-RFFE registers

Write '1' to this bit to reset all the MIPI-RFFE registers from address 0x00 to 0x3F, except RFFE_PM_TRIG, RFFE_GROUP_SID, RFFE_USID_0, RFFE_USID_1 and RFFE_USID_2.

This bit will always Read-back '0'.

The soft reset occurs in the last clock cycle of the MIPI-RFFE frame which Writes '1' to this bit.

Right immediately after this frame, all the MIPI-RFFE registers have the reset value and are ready to be reprogrammed as desired.

RFFE_STATUS Bits [6:0] are set '1' by hardware to flag when a certain condition is detected, as described below. RFFE_STATUS Bits [6:0] cannot be written, but it is cleared to '0' under following conditions:

- ◆ Hardware Self-reset is applied after RFFE_STATUS is READ
- ◆ When SWR is written '1'
- ◆ When power mode transitions through STARTUP mode '01'
- ◆ After Power-up Reset

CFPE

1: Command frame with parity error received.

On the occurrence of this error, the slave will ignore the entire Command Sequence

CLE

1: Incompatible command length, due to unexpected SSC received before command length to be completed.

On the occurrence of this error, the slave will accept Write data up to the last correct and complete frame.

When MIPI-RFFE multi-byte Read command is detected, the slave will always replay with an extended Read command of length of one byte.

AFPE

1: Address frame with parity error received.

On the occurrence of this error, the slave will ignore the entire Command Sequence

DFPE

1: Data frame with parity error received.

On the occurrence of this error, the slave will ignore only the erroneous data byte (s)

RURE

1: Read of non-existent register was detected.

On the occurrence of this error, the slave will not respond to the Read command frame. It will keep the bus idle.

WURE

1: Write to non-existent register was detected.

On the occurrence of this error, the slave discards data being written, and on the next received frame, proceeds as normal

BGE

1: Read using the Broadcast ID was detected

On the occurrence of this error, the slave will ignore the entire Command Sequence

TCC-404

Register RFFE:	RFFE_GROUP_SID	Address RFFE A[4:0]:	0x1B
----------------	----------------	----------------------	------

Reset Source: nreset_dig or PWR_MODE = 'X1' (transition through STARTUP mode)

	7	6	5	4	3	2	1	0
Bits	Reserved	Reserved	Reserved	Reserved	GSID[3]	GSID[2]	GSID[1]	GSID[0]
Reset	0	0	0	0	W-0	W-0	W-0	W-0

GSID = Group Slave Identifier Register

NOTE: The GSID [3:0] field can be written directly by messages using USID_0, USID_1 or USID_2.

NOTE: GSID value is NOT retained during SHUTDOWN power mode.

NOTE: GSID value is not affected by SWR bit from RFFE_STATUS register

NOTE: Frames using slave address = GSID, can write only to RFFE_PM_TRIG [7:6] and [2:0].

NOTE: RFFE READ frames containing GSID will be ignored

Register RFFE:	RFFE_PM_TRIG	Address RFFE A[4:0]:	0x1C
----------------	--------------	----------------------	------

Reset Source: nreset_dig or PWR_MODE = 'X1' (transition through STARTUP mode)

	7	6	5	4	3	2	1	0
Bits	Power Mode (Note 4)	Trigger Mask 2 (Notes 1, 2, 3)	Trigger Mask 1 (Notes 1, 2, 3)	Trigger Mask 0 (Notes 1, 2, 3)	Trigger 2 (Note 4)	Trigger 1 (Note 4)	Trigger 0 (Note 4)	
Reset	W-0	W-0	W-1	W-1	W-1	W-0	W-0	W-0

1. The Trigger Mask 2 (bit [5]) can be changed, either set or cleared, only with an individual message using USID_2. The Trigger Mask 1 (bit [4]) can be changed, either set or cleared, only with an individual message using USID_1. The Trigger Mask 0 (bit [3]) can be changed, either set or cleared, only with an individual message using USID_0.
2. During broadcast MIPI-RFFE accesses using Broadcast ID or GSID, Trigger bits [2:0] are masked by the pre-existent setting of Trigger Mask bits [5:3].
3. During Individual MIPI-RFFE accesses, Trigger bits [2:0] are masked by the incoming Trigger Mask bits [5:3] within the same write message to RFFE_PM_TRIG register according to the DAC DUR configurations.
4. Power mode field bits [7:6] and Triggers bits [2:0] can be changed by either MIPI-RFFE broadcast messages (with GSID or Broadcast ID slave address). The power mode can be changed by all USID accesses. The trigger bits can be set by individual messages when slave address fields within the Register Write Command is are equal to their corresponding control USIDs.

NOTE: None of the 8 bits of RFFE_PM_TRIG register bits are affected by SWR bit from RFFE_STATUS register. The default reset values of the Trigger Masks are set to '1' violating the RFFE spec, but the trigger at DAC write is requested to be the default

Bit [7:6]: Power Mode

00: **ACTIVE mode**, defined by following hardware behavior:

- ◆ Boost Control active, VHV set by Digital Interface
- ◆ Vout A, B, C, D enabled and controlled by Digital Interface

01: **STARTUP mode**, defined by following hardware behavior:

- ◆ Boost Control active, VHV set by Digital Interface
- ◆ Vout A, B, C, D disabled

10: **LOW POWER mode** is defined by following hardware behavior:

- ◆ Digital interface is active, while all other circuits are in low power mode

11: **STARTUP mode**, defined by following hardware behavior:

- ◆ Boost Control active, VHV set by Digital Interface
- ◆ Vout A, B, C, D disabled

Bit 5: Mask trigger 2 (only USID_2 write access)

0: Trigger 2 not masked. The DACs, which are configured in their DUR to be controlled by USID_2 have their active registers updated after the Trigger 2 is written a value of 1.

1: Trigger 2 is masked. The DACs, which are configured in their DUR to be controlled by USID_2 have their active registers updated as soon as their new DAC values are written in (default).

Bit 4: Mask trigger 1 (only USID_1 write access)

0: Trigger 1 not masked. The DACs, which are configured in their DUR to be controlled by USID_1 have their active registers updated after the Trigger 1 is written a value of 1.

1: Trigger 2 is masked. The DACs, which are configured in their DUR to be controlled by USID_1 have their active registers updated as soon as their new DAC values are written in (default).

Bit 3: Mask trigger 0 (only USID_0 write access)

0: Trigger 0 not masked. The DACs, which are configured in their DUR to be controlled by USID_0 have their active registers updated after the Trigger 0 is written a value of 1.

TCC-404

1: Trigger 2 is masked. The DACs, which are configured in their DUR to be controlled by USID_0 have their active registers updated as soon as their new DAC values are written in (default).

Bit 2: Trigger 2 (USID_2 or broadcast write access)

Write 1 to this bit, to move data in DACs, which are configured in their DUR under USID_2 control, from shadow registers into active registers. This trigger can be masked by bit 5. The read back of this field returns DACC OR DACD pending trigger status (from immediate or SW trigger). A high state read back implies that either DACC or DACD has a pending trigger.

Bit 1: Trigger 1 (USID_1 or broadcast write access)

Write 1 to this bit, to move data in DACs, which are configured in their DUR under USID_1 control, from shadow registers into active registers. This trigger can be masked by bit 4. The read back of this field returns DACB pending trigger status (from immediate or SW trigger).

Bit 0: Trigger 0 (USID_0 or broadcast write access)

Write 1 to this bit, to move data in DACs, which are configured in their DUR under USID_0 control, from shadow registers into active registers. This trigger can be masked by bit 3. The read back of this field returns DACA pending trigger status (from immediate or SW trigger).

Register RFFE:	RFFE_PRODUCT_ID	Address RFFE A[4:0]:	0x1D
----------------	-----------------	----------------------	------

Reset Source: N/A

	7	6	5	4	3	2	1	0
Bits	PID7	PID6	PID5	PID4	PID3	PID2	PID1	PID0
Reset	0	1	0	0	0	0	0	0

Bits [7:1] are hardcoded in ASIC

Bit [0] depends on version – 0 for TCC-404A

PRODUCT Family ID History:

TCC-103A	0	0	0	0	0	1	0	0
TCC-106A	0	0	0	0	1	0	0	0
TCC-202A	0	0	1	0	0	0	0	0
TCC-206A	0	0	1	0	0	1	0	IDB0 pin
TCC-303A	0	0	0	1	0	0	0	0
TCC-404A	0	1	0	0	0	0	0	0

Register RFFE:	RFFE_MANUFACTURER_ID	Address RFFE A[4:0]:	0x1E
----------------	----------------------	----------------------	------

Reset Source: N/A

	7	6	5	4	3	2	1	0
Bits	MPN7	MPN6	MPN5	MPN4	MPN3	MPN2	MPN1	MPN0
Reset	0	0	1	0	1	1	1	0

The 10 MPN bits (MPN0 to MPN9 partially residing under USID registers) are manufacturing ID bits unique to ON Semiconductor.

Register RFFE:	RFFE_USID_0 (default)	Address RFFE A[4:0]:	0x1F
----------------	-----------------------	----------------------	------

Reset Source: nreset_dig or SWR = '1' or PWR_MODE = 'X1' (transition through STARTUP mode)

	7	6	5	4	3	2	1	0
Bits	Reserved (2)		MPN9 (2)	MPN8 (2)	USID3 (1)	USID2 (1)	USID1 (1)	USID0 (1)
Reset	0	0	0	1	W-0	W-1	W-1	W-1

USID = Unique Slave Identifier Register

1. USID field can be changed by:

- ◆ MIPI-RFFE broadcast messages when USID field within the Register Write Command is 0b0000
- ◆ MIPI-RFFE individual messages when USID field within the Register Write Command equal with content of RFFE_REG_0x1F[3:0]

2. In the sequence of writing USID field, the upper [7:4] must match the value 0b0001 hardcoded in the RFFE register 0x1F

NOTE: USID value is NOT retained during SHUTDOWN power mode.

TCC-404

Register RFFE:	RFFE_GROUP_SID_EXT	Address RFFE A[5:0]:	0x22
----------------	--------------------	----------------------	------

Reset Source: nreset_dig or PWR_MODE = 'X1' (transition through STARTUP mode)

	7	6	5	4	3	2	1	0
Bits	Reserved	Reserved	Reserved	Reserved	GSID[3]	GSID[2]	GSID[1]	GSID[0]
Reset	U-0	U-0	U-0	U-0	W-0	W-0	W-0	W-0

This register is the exact re-mapping from address 0x1B the RFFE_GROUP_SID. The Group ID is defined to be located at address 0x22 by RFFE2.0. In TCC404 it can be accessed at either 0x1B or 0x22.

Register RFFE:	UDR_RST	Address RFFE A[5:0]:	0x23
----------------	---------	----------------------	------

Reset Source: nreset_dig or PWR_MODE = 'X1' (transition through STARTUP mode)

	7	6	5	4	3	2	1	0
Bits	SWR	Reserved (RFFE 2.0)						
Reset	W-0	U-0	U-0	U-0	U-0	U-0	U-0	U-0

This register is the exact re-mapping from address 0x1A the RFFE_STATUS SWR bit. This reset is defined to be located at address 0x23 by RFFE2.0. In TCC404 it can be accessed at either at 0x1A or 0x23.

RFFE 2.0 defines broadcast access support into this field. In TCC404 this is not supported.

Register RFFE:	ERR_SUM	Address RFFE A[5:0]:	0x24
----------------	---------	----------------------	------

Reset Source: nreset_dig or PWR_MODE = 'X1' (transition through STARTUP mode)

	7	6	5	4	3	2	1	0
Bits	Reserved	CFPE	CLE	AFPE	DFPE	RURE	WURE	BGE
Reset	U-0	R-0	R-0	R-0	R-0	R-0	R-0	R-0

This register is the exact re-mapping from address 0x1A the RFFE_STATUS error bits. These rffe errors are defined to be located at address 0x24 by RFFE2.0. In TCC404 it can be accessed at either at 0x1A or 0x24. The RFFE 2.0 does not define the individual sub fields.

Register RFFE:	TEST_PATT	Address RFFE A[5:0]:	0x2C
----------------	-----------	----------------------	------

Reset Source: N/A

	7	6	5	4	3	2	1	0
Bits	RFFE 2.0 FIXED TEST PATTERN							
Reset	R-1	R-1	R-0	R-1	R-0	R-0	R-1	R-0

This field is intended to be used by the device manufacturers as a standardized location where a known, fixed test pattern could be sourced from a given address location. This pattern is defined as 0xD2 by the standard

Register 0 Write Command Sequence

The Command Sequence starts with an SSC which is followed by the Register 0 Write Command Frame. This Frame contains the Slave address, a logic one, and the seven bit word that will be written to Register 0. The Command Sequence is depicted below.

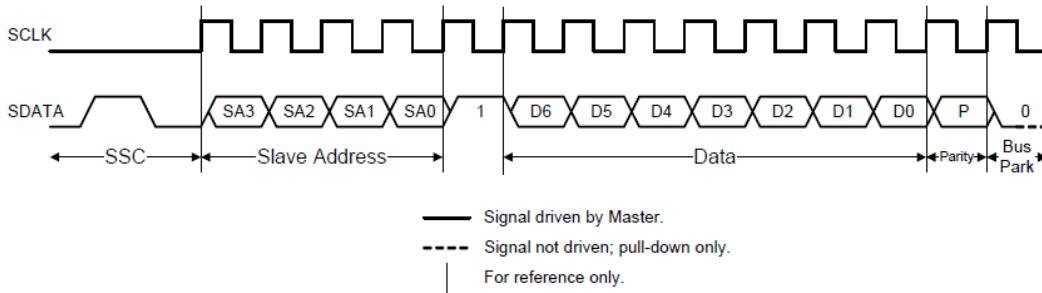

Figure 14. Register 0 Write Command Sequence

Table 15. RFFE COMMAND FRAME FOR REGISTER 0 WRITE COMMAND SEQUENCE

Description	SSC		Command Frame										BP
DAC Enables	1	0	SA [3,0]	1	0	0	0	1	1	1	1	P	BP

Single Register Write Command Sequence

The Write Register command sequence may be used to access each register individually (addresses 0–31).

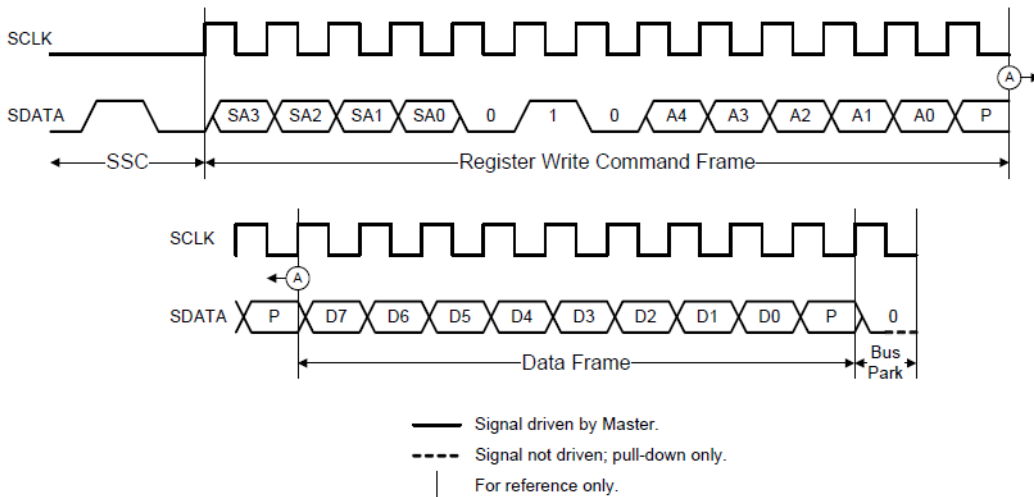

Figure 15. Single Register Write Command Sequence

Table 16. RFFE COMMAND FRAME for REGISTER WRITE COMMAND SEQUENCE for DACS LOADING PROCEDURE

Description	SSC		Command Frame										Data Frame		BP
Register Write DAC A	1	0	SA [3, 0]	0	1	0	0	0	1	1	0	P	GL_A & DAC_A [6:0]	P	BP
Register Write DAC B	1	0	SA [3, 0]	0	1	0	0	0	1	1	1	P	GL_B & DAC_B [6:0]	P	BP
Register Write DAC C	1	0	SA [3, 0]	0	1	0	0	1	0	0	0	P	GL_C & DAC_C [6:0]	P	BP
Register Write DAC D	1	0	SA [3, 0]	0	1	0	0	1	0	0	1	P	GL_D & DAC_D [6:0]	P	BP

This sequence can be used for Read/Write procedure for some other purposes as shown on the following table:

Table 17. OTHER RFFE COMMAND SEQUENCES

Description	SSC		Command Frame								Data Frame								BP				
Active Mode	1	0	SA [3, 0]	0	1	0	1	1	1	0	0	P	0	0	x	x	x	x	x	x	P	BP	
Startup Mode	1	0	SA [3, 0]	0	1	0	1	1	1	0	0	P	0	1	x	x	x	x	x	x	P	BP	
Low Power	1	0	SA [3, 0]	0	1	0	1	1	1	0	0	P	1	0	x	x	x	x	x	x	P	BP	
Reserved	1	0	SA [3, 0]	0	1	0	1	1	1	0	0	P	1	1	x	x	x	x	x	x	P	BP	
Product ID	1	0	SA [3, 0]	0	1	0	1	1	1	0	1	P	0	1	0	0	0	0	0	0	0/1	P	BP
Manufacturer ID	1	0	SA [3, 0]	0	1	0	1	1	1	1	0	P	0	0	1	0	1	1	1	0	P	BP	
Manufacturer USID	1	0	SA [3, 0]	0	1	0	1	1	1	1	1	P	0	0	0	1	USID				P	BP	

Extended Register Write Command Sequence

In order to access more than one register in one sequence or to access the registers in address range 0x20-0x3F this message could be used. Most commonly it will be used for loading four DAC registers at the same time. The four LSBs of the Extended Register Write Command Frame determine the number of bytes that will be written by the Command Sequence. A value of 0b0000 would write one byte and a value of 0b1111 would write sixteen bytes.

If more than one byte is to be written, the register address in the Command Sequence contains the address of the first extended register that will be written to and the Slave's local extended register address shall be automatically incremented by one for each byte written, starting from the address indicated in the Address Frame.

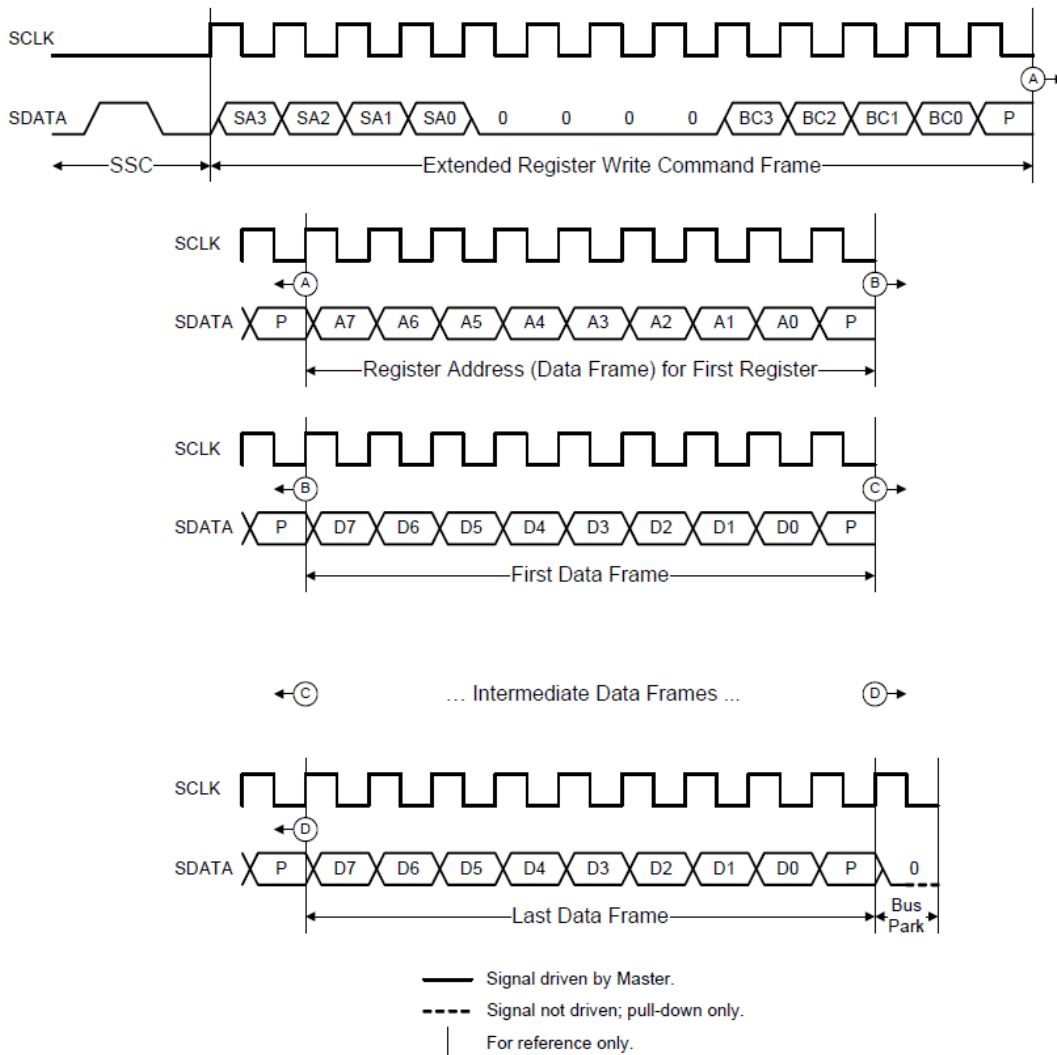

Figure 16. Extended Register Write Command Sequence

Table 18. RFFE Command Frame for Extended Register Write Command Sequence for DACs Loading Procedure

Description	SSC		Command Frame										Address Frame						Data Frame						Bus Park						
Extended Register Write DAC A&B&C&D	1	0	SA [3:0]	0	0	0	0	0	0	0	1	1	P	0	0	0	0	0	1	1	0	P	GL_A & DAC_A	P	GL_B & DAC_B	P	GL_C & DAC_C	P	GL_D & DAC_D	P	BP

Extended or Single Register Read Command Sequence

MIPI-RFFE Read operation can access any register from address 0x00 to 0x3F without the need to enter testkey. Both single Register Read and Extended Register Read commands are supported.

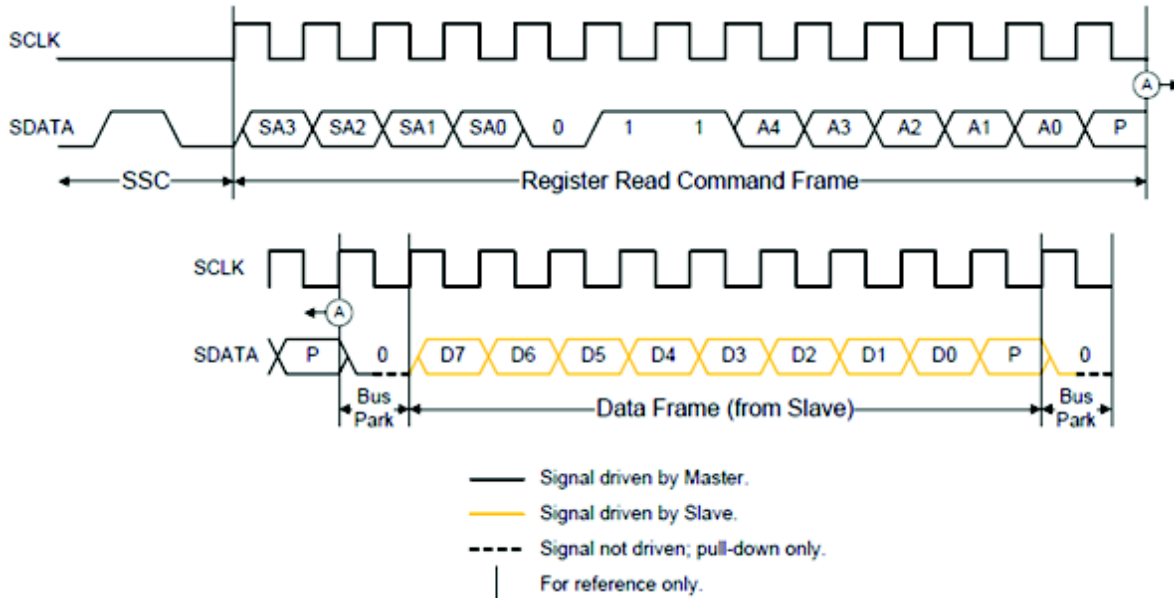

Figure 17. Single Register Read Command Sequence

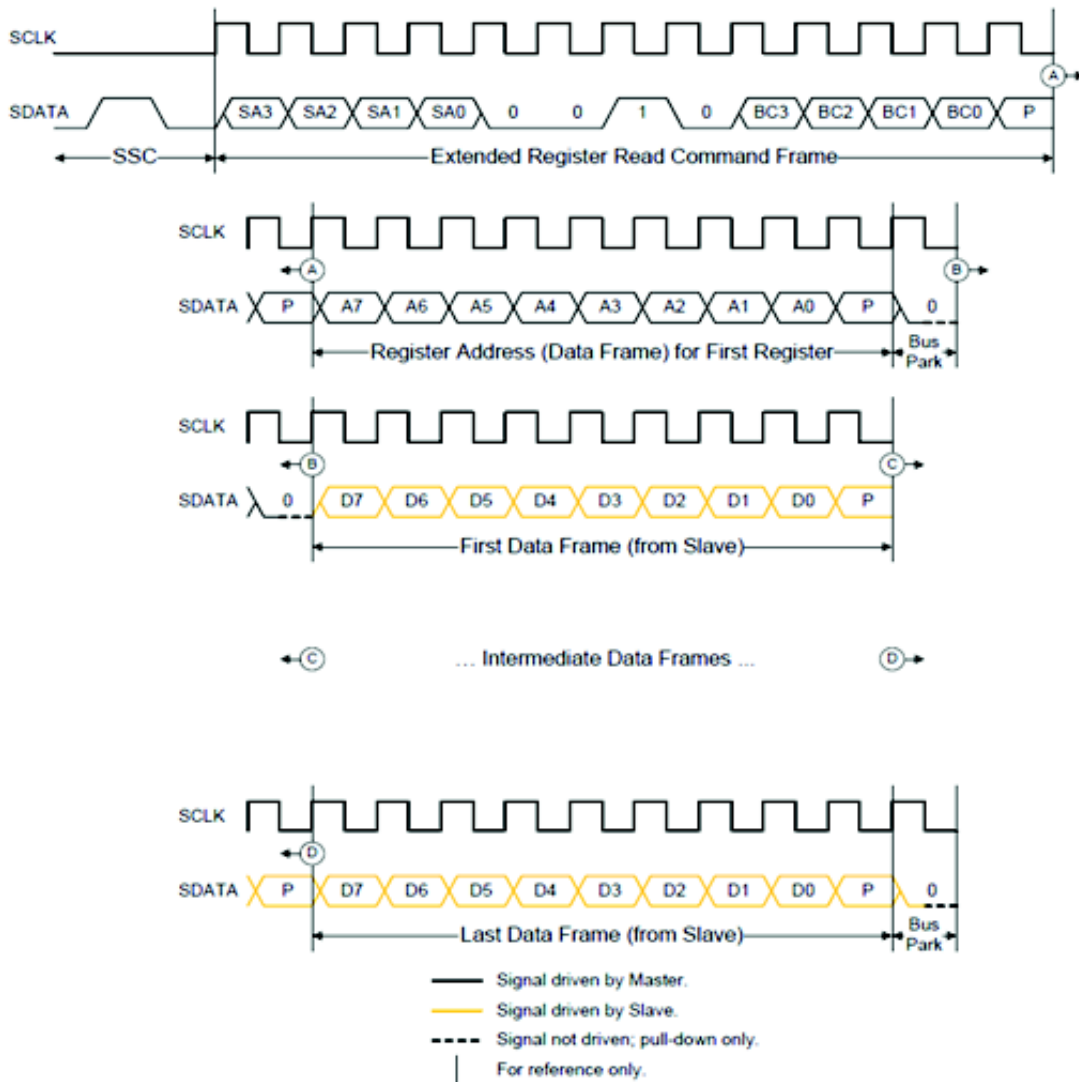

Figure 18. Extended Register Read Command Sequence

Extended Register Write/Read DAC Register Address Jump with DUR

This functionality is enabled by setting the extended dac jump bit under RFFE_REG_0x00. This configuration evaluates the address increment condition based on the DUR settings of the next registers and the Slave ID value utilized by the frame.

- The evaluation at the increment does not skip more than four addresses. This implies that if none of the DAC registers are accessible at their DUR evaluation, the jump stops at 4th address increment and executes a write, which does not go through. The evaluation restarts from this address. This is not a real use case.

The write or read access shall intend to access at least one of the DACs registers.

- If the DUR of the corresponding DAC is set to 0x3, these DAC register addresses can't be skipped. It responds to all three USIDs programmed.

A DAC register address would be skipped in access at the extended increment if its DUR is set to 0x0, 0x1 or 0x2 and the Slave ID used in the access does not match to the USID the DAC is governed with.

Changing USIDs

Changing USID is according to MIPI RFFE specifications. Same Manufacturer_ID and Product_ID apply for USID_0/_1/_2. Note that USID can be changed with broadcast commands, or commands targeting that particular USID. For example to change USID_0, broadcast commands or commands addressing USID_0 can be used.

Change USID_0

- RFFE_WRITE_REG 0x1D [0x40 + OTP[36]]
- RFFE_WRITE_REG 0x1E 0x2E
- RFFE_WRITE_REG 0x1F 0x1Z, where Z is the new USID_0 value

Change USID_1

- RFFE_WRITE_REG 0x1D [0x40 + OTP[36]]
- RFFE_WRITE_REG 0x1E 0x2E
- RFFE_WRITE_REG 0x18 0x1Z, where Z is the new USID_1 value

Change USID_2

- RFFE_WRITE_REG 0x1D [0x40 + OTP[36]]
- RFFE_WRITE_REG 0x1E 0x2E
- RFFE_WRITE_REG 0x19 0x1Z, where Z is the new USID_2 value

EXAMPLE DEVICE OPERATION

Device Setup

1. Enable all four DACs – Write 0x0F to Register 0x00
2. Change VHV voltage to 28 V (Default 28 V)

Change DACs

- Change DACA voltage to 6.8 V; no Glide – Write 0x24 to Register 0x06
- Change DACB voltage to 12.0 V; no Glide – Write 0x40 to Register 0x07
- Change DACC voltage to 0.9 V; no Glide – Write 0x05 to Register 0x08
- Change DACD voltage to 6.8 V; no Glide – Write 0x24 to Register 0x09

Setup Glide

- Set DACs Glide step duration to 28 μ s – Write 0x0D to Register 0x03

Change DACs with Glide

- Keep DACA voltage at 6.8 V; Glide enabled – Write 0xA4 to Register 0x06 (Total Glide duration is $28 \mu\text{s} * 256 \mu\text{s} = 7168 \mu\text{s}$); No output change since $\text{DAC_OLD} = \text{DAC_NEW}$
- Change DACB voltage to 16.4 V; Glide enabled – Write 0xD7 to Register 0x07 (Total Glide duration is $28 \mu\text{s} * 256 \mu\text{s} = 7168 \mu\text{s}$); Transitions from 12 V to 16.4 V over 7.168 ms
- Change DACC Voltage to 20.5 V; Glide enabled – Write 0xED to Register 0x08 (Total Glide Duration is $28 \mu\text{s} * 256 \mu\text{s} = 7168 \mu\text{s}$); Transitions from 0.9 V to 20.5 V over 7.168 ms
- Change DACD voltage to 16.4 V; Glide enabled – Write 0xD7 to Register 0x09 (Total Glide duration is $28 \mu\text{s} * 256 \mu\text{s} = 7168 \mu\text{s}$); Transition from 6.8 V to 16.4 V over 7.168 ms

NOTE: Any sequential registers (Eg. 0x03–0x0D, as mentioned in Setup Glide and Change DACs with Glide sections) can be written with a single extended MIPI write, rather than individual write commands.

TCC-404

Following picture shows TCC-404 and all the necessary external components

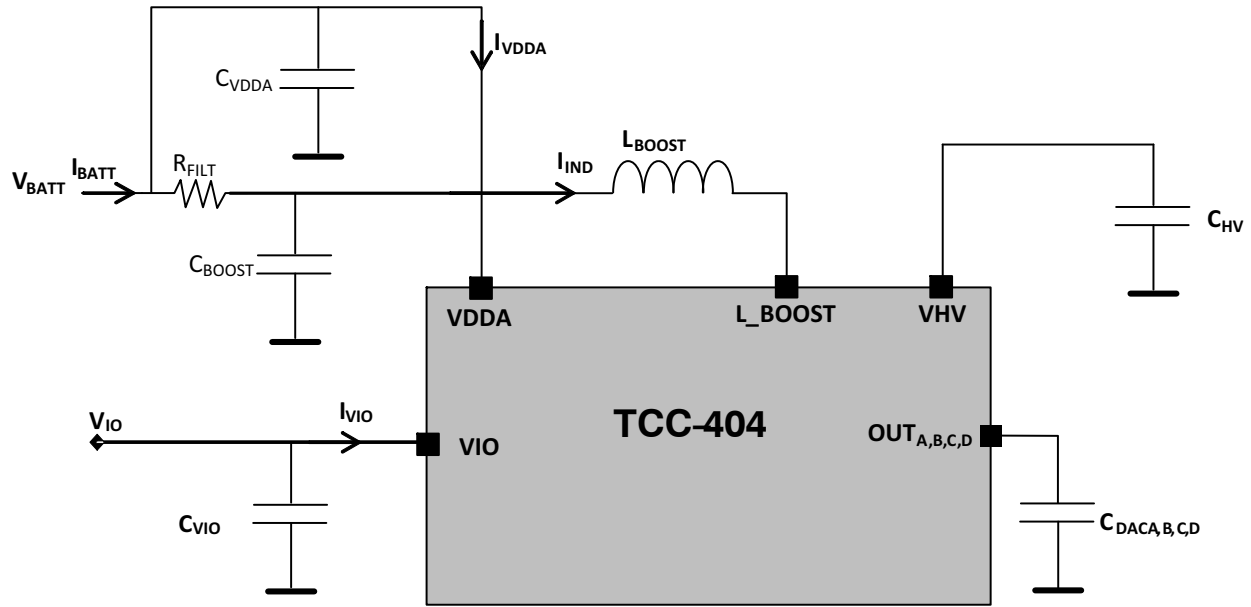

Figure 19. TCC-404 with External Components

Table 19. RECOMMENDED EXTERNAL BOM

Component	Description	Nominal Value	Package	Recommended P/N
C _{BOOST}	Boost Supply Capacitor, 10 V	1 μ F	0402	TY: JMK105BJ105KV-F
L _{BOOST}	Boost Inductor	2.2 μ H to 4.7 μ H	0603	2.2 μ H: TY MBKK1608T2R2 3.3 μ H: TY MBKK1608T3R3M 4.7 μ H: TY MBKK1608T4R7M
R _{FILT}	Filtering resistor, 5%	3.3 Ω	0402	Yageo : RC0402JR-073R3L
C _{VIO}	V _{IO} Supply Decoupling, 10 V	100 nF	0201	Murata: GRM033R61A104ME15D
C _{VDDA}	V _{VDDA} Supply Decoupling, 10 V	1 μ F	0402	TY : JMK105BJ105KV-F
C _{HV}	Boost Tank Capacitor, 50 V	47 nF	0402	Murata: GRM155R71H473KA01J
C _{dacA,B,C,D}	Decoupling Capacitor, 50 V (Note 5)	100 pF	0201	Murata: GRM0335C1H101JD01D

5. Recommended in noise reduction only– not essential but place next to PTIC if used

Table 20. ORDERING INFORMATION

Device	Marking	Package	Shipping [†]
TCC-404A-RT	T44a	WLCSP12 (Pb-Free)	3000 / Tape & Reel
TCC-404B-RT	T44b		

[†]For information on tape and reel specifications, including part orientation and tape sizes, please refer to our Tape and Reel Packaging Specifications Brochure, BRD8011/D.

ASSEMBLY INSTRUCTIONS

Note: It is recommended that under normal circumstances, this device and associated components should be located in a shielded enclosure.



WLCSP12, 1.575x1.025x0.68
CASE 567WF
ISSUE A

DATE 11 JUL 2018

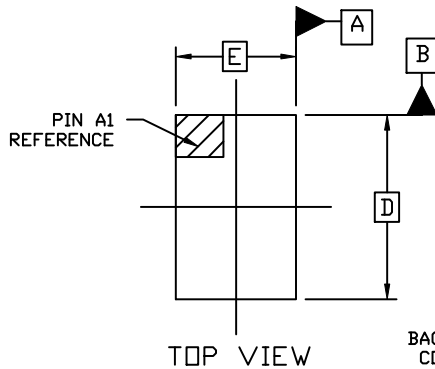

TOP VIEW

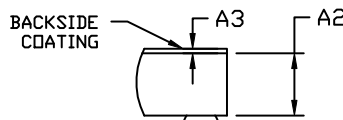

DETAIL A

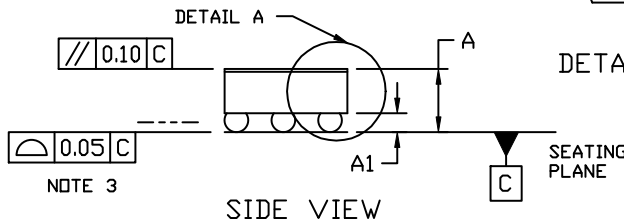

SIDE VIEW

NOTES:

1. DIMENSIONING AND TOLERANCING PER ASME Y14.5M, 1994.
2. CONTROLLING DIMENSION: MILLIMETERS
3. COPLANARITY APPLIES TO THE SPHERICAL CROWNS OF THE SOLDER BALLS.

DIM	MILLIMETERS	
	MIN.	MAX.
A	---	0.68
A1	0.13	0.19
A2	0.38 REF	
A3	0.025 REF	
b	0.17	0.23
D	1.575 BSC	
E	1.025 BSC	
e	0.35 BSC	

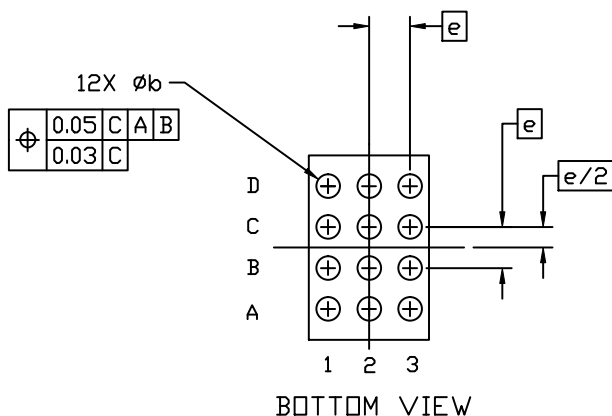

BOTTOM VIEW

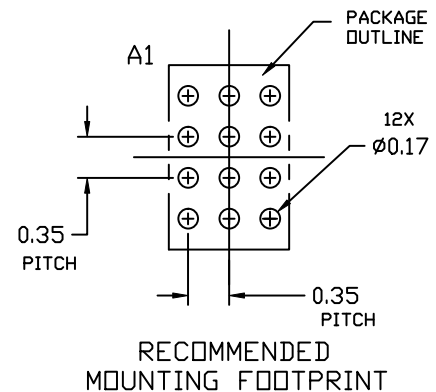

RECOMMENDED MOUNTING FOOTPRINT

GENERIC MARKING DIAGRAM*

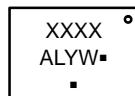

- A = Assembly Location
- L = Wafer Lot
- Y = Year
- W = Work Week
- = Pb-Free Package

(Note: Microdot may be in either location)

*This information is generic. Please refer to device data sheet for actual part marking. Pb-Free indicator, "G" or microdot "▪", may or may not be present. Some products may not follow the Generic Marking.

DOCUMENT NUMBER:	98AON86772G	Electronic versions are uncontrolled except when accessed directly from the Document Repository. Printed versions are uncontrolled except when stamped "CONTROLLED COPY" in red.
DESCRIPTION:	WLCSP12, 1.575x1.025x0.68	PAGE 1 OF 1

ON Semiconductor and are trademarks of Semiconductor Components Industries, LLC dba ON Semiconductor or its subsidiaries in the United States and/or other countries. ON Semiconductor reserves the right to make changes without further notice to any products herein. ON Semiconductor makes no warranty, representation or guarantee regarding the suitability of its products for any particular purpose, nor does ON Semiconductor assume any liability arising out of the application or use of any product or circuit, and specifically disclaims any and all liability, including without limitation special, consequential or incidental damages. ON Semiconductor does not convey any license under its patent rights nor the rights of others.

ON Semiconductor and  are trademarks of Semiconductor Components Industries, LLC dba ON Semiconductor or its subsidiaries in the United States and/or other countries. ON Semiconductor owns the rights to a number of patents, trademarks, copyrights, trade secrets, and other intellectual property. A listing of ON Semiconductor's product/patent coverage may be accessed at www.onsemi.com/site/pdf/Patent-Marking.pdf. ON Semiconductor reserves the right to make changes without further notice to any products herein. ON Semiconductor makes no warranty, representation or guarantee regarding the suitability of its products for any particular purpose, nor does ON Semiconductor assume any liability arising out of the application or use of any product or circuit, and specifically disclaims any and all liability, including without limitation special, consequential or incidental damages. Buyer is responsible for its products and applications using ON Semiconductor products, including compliance with all laws, regulations and safety requirements or standards, regardless of any support or applications information provided by ON Semiconductor. "Typical" parameters which may be provided in ON Semiconductor data sheets and/or specifications can and do vary in different applications and actual performance may vary over time. All operating parameters, including "Typicals" must be validated for each customer application by customer's technical experts. ON Semiconductor does not convey any license under its patent rights nor the rights of others. ON Semiconductor products are not designed, intended, or authorized for use as a critical component in life support systems or any FDA Class 3 medical devices or medical devices with a same or similar classification in a foreign jurisdiction or any devices intended for implantation in the human body. Should Buyer purchase or use ON Semiconductor products for any such unintended or unauthorized application, Buyer shall indemnify and hold ON Semiconductor and its officers, employees, subsidiaries, affiliates, and distributors harmless against all claims, costs, damages, and expenses, and reasonable attorney fees arising out of, directly or indirectly, any claim of personal injury or death associated with such unintended or unauthorized use, even if such claim alleges that ON Semiconductor was negligent regarding the design or manufacture of the part. ON Semiconductor is an Equal Opportunity/Affirmative Action Employer. This literature is subject to all applicable copyright laws and is not for resale in any manner.

PUBLICATION ORDERING INFORMATION

LITERATURE FULFILLMENT:

Email Requests to: orderlit@onsemi.com

ON Semiconductor Website: www.onsemi.com

TECHNICAL SUPPORT

North American Technical Support:
Voice Mail: 1 800-282-9855 Toll Free USA/Canada
Phone: 011 421 33 790 2910

Europe, Middle East and Africa Technical Support:

Phone: 00421 33 790 2910

For additional information, please contact your local Sales Representative

