

ON Semiconductor

Is Now

onsemi™

To learn more about onsemi™, please visit our website at
www.onsemi.com

onsemi and **onsemi** and other names, marks, and brands are registered and/or common law trademarks of Semiconductor Components Industries, LLC dba "**onsemi**" or its affiliates and/or subsidiaries in the United States and/or other countries. **onsemi** owns the rights to a number of patents, trademarks, copyrights, trade secrets, and other intellectual property. A listing of **onsemi** product/patent coverage may be accessed at www.onsemi.com/site/pdf/Patent-Marking.pdf. **onsemi** reserves the right to make changes at any time to any products or information herein, without notice. The information herein is provided "as-is" and **onsemi** makes no warranty, representation or guarantee regarding the accuracy of the information, product features, availability, functionality, or suitability of its products for any particular purpose, nor does **onsemi** assume any liability arising out of the application or use of any product or circuit, and specifically disclaims any and all liability, including without limitation special, consequential or incidental damages. Buyer is responsible for its products and applications using **onsemi** products, including compliance with all laws, regulations and safety requirements or standards, regardless of any support or applications information provided by **onsemi**. "Typical" parameters which may be provided in **onsemi** data sheets and/or specifications can and do vary in different applications and actual performance may vary over time. All operating parameters, including "Typicals" must be validated for each customer application by customer's technical experts. **onsemi** does not convey any license under any of its intellectual property rights nor the rights of others. **onsemi** products are not designed, intended, or authorized for use as a critical component in life support systems or any FDA Class 3 medical devices or medical devices with a same or similar classification in a foreign jurisdiction or any devices intended for implantation in the human body. Should Buyer purchase or use **onsemi** products for any such unintended or unauthorized application, Buyer shall indemnify and hold **onsemi** and its officers, employees, subsidiaries, affiliates, and distributors harmless against all claims, costs, damages, and expenses, and reasonable attorney fees arising out of, directly or indirectly, any claim of personal injury or death associated with such unintended or unauthorized use, even if such claim alleges that **onsemi** was negligent regarding the design or manufacture of the part. **onsemi** is an Equal Opportunity/Affirmative Action Employer. This literature is subject to all applicable copyright laws and is not for resale in any manner. Other names and brands may be claimed as the property of others.

NCS5651MNSGEVB

NCS5651MNSG Evaluation Board User's Manual



ON Semiconductor®

www.onsemi.com

EVAL BOARD USER'S MANUAL

Introduction

The NCS5651MNSGEVB is an evaluation board for the NCS5651 operational amplifier.

The NCS5651 is a high efficiency, class B, low distortion power line driver. It incorporates two operational amplifiers (opamps). The output opamp is designed to drive up to 2 A peak. At an output current of 1.5 A, the output voltage is guaranteed to swing within 1 V or less of either rail, giving the user improved SNR. In addition to the output amplifier, a small-signal opamp is provided which can be configured as a unity gain follower buffer or can provide a stage of a 4-pole low pass filter.

Although the NCS5651 is designed for power line communication (PLC) applications, it is equally suitable to drive actuators or motors, or for any application where a robust power amplifier is required.

For more information refer to [1, 2, 3].

Description

The evaluation boards are small ($26 \times 23.5 \text{ mm}^2$) printed circuit boards (Figure 1) carrying the NCS5651 line driver. The schematic is appended at the end of this document.

An NCP4640H033 linear regulator is provided to derive the 3.3 V V_{uc} voltage. The latter determines the output voltage of the warning output pins of the line driver. These three pins (viz. the thermal warning flag, the thermal shutdown flag, and the current limitation flag) are connected to LEDs.

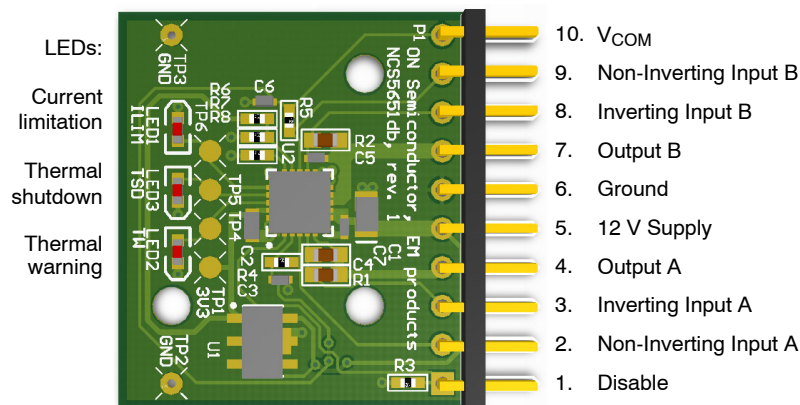

Figure 1. NCS5651MNSGEVB Outline

A 2.54 mm-pitch header with ten pins brings the most important signals outside.

Besides the ground and 12 V supply pin, these include the line driver disable and 6 V V_{com} bias voltage generated by the line driver. Both signals can be left open if unused.

All pins of the two operational amplifiers are available on the header. As a result, any opamp topology can be realized by fitting the appropriate external feedback and biasing network.

To ensure stability, 10 pF ceramic capacitors are fitted on the board between the inverting input and the output of each opamp. This must be taken into account if an external capacitance is added, as is the case with a multi-feedback (MFB) topology.

For convenience, a 3 k Ω resistor is also fitted between the non-inverting input and V_{com} . If this biasing is not required, for instance to realize a Sallen and Key filter topology, the resistor should be removed.

NCS5651MNSGEVB

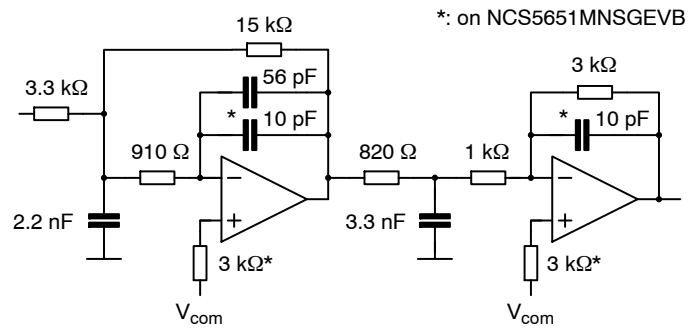

Figure 2. Recommended Transmission Filter for PLC with PL110 Carrier Frequencies

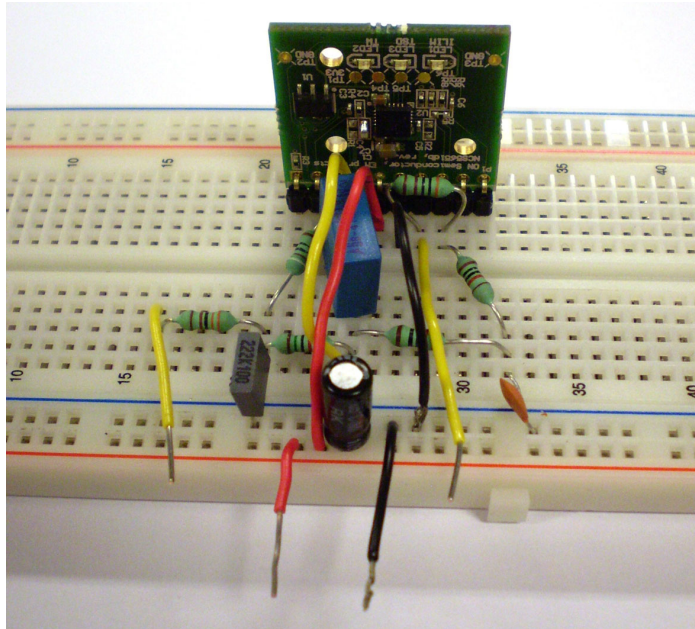

Figure 3. The Schematic of Figure 2 Built on Breadboard with an NCS5651MNSGEVB

Application Ideas

The size and header of the evaluation board make it perfectly suited for breadboarding. For instance, Figure 2 shows the recommended transmission filter for PLC S-FSK* with the PL110 carrier frequencies (105 and 115 kHz). This schematic is easily realized on breadboard (Figure 3).

Some applications require a lower copper-to-ambient thermal resistance (R_{CuA}) to improve line driver cooling. The board design makes it possible to fit a heat sink on the bottom side: solder mask openings and mounting holes are foreseen.

The heat sink can be mounted with thermally conducting adhesive tape (Figure 4). For more information on cooling, refer to [1, 4].

Fischer Elektronik ICK SMD B 19 SA is recommended. It may be obtained through Farnell (ref. 4302266) or Newark (ref. 34M6437).

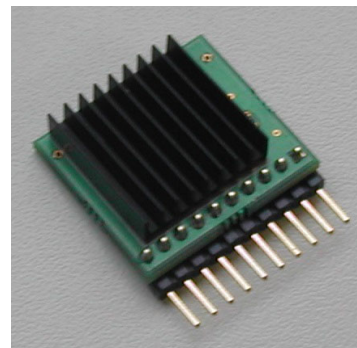

Figure 4. Adding a Heat Sink to Improve Cooling

*Spread-frequency shift keying (S-FSK) is a modulation scheme widely used in power line communication (PLC). It combines simplicity (and thus allows a low cost implementation) with good resilience.

NCS5651MNSGEVB

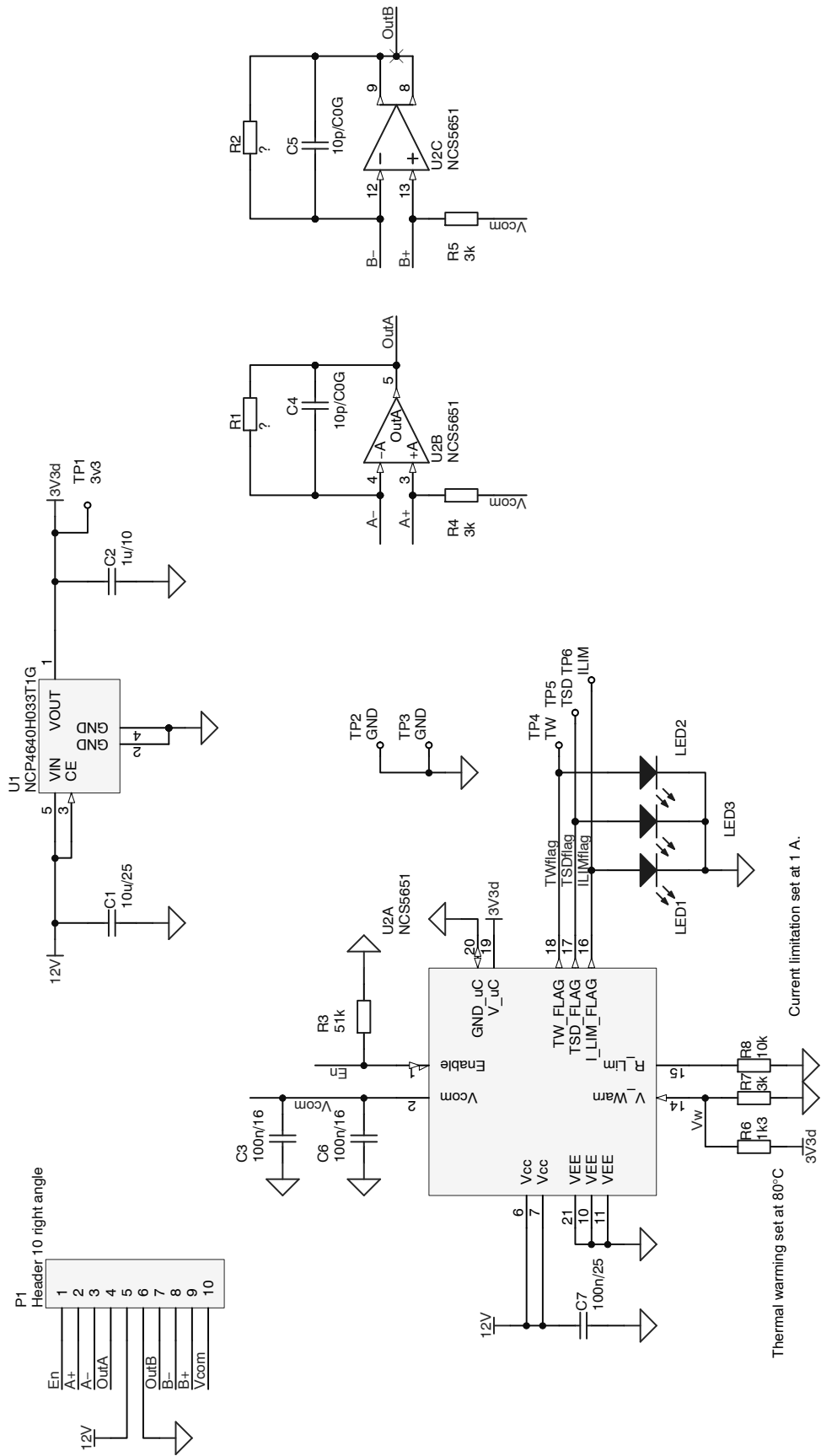

Figure 5. NCS5651MNSGEVB Schematic

NCS5651MNSGEVB

References

- [1] ON Semiconductor. Evaluation kit for power-line communication user manual, December 2014.
- [2] ON Semiconductor. Getting started with power line communication (application note AND9165/D), June 2014. Online at www.onsemi.com/pub_link/Collateral/AND9165-D.PDF.
- [3] ON Semiconductor. NCS5651 2 Amp PLC line driver datasheet, December 2014. Online at www.onsemi.com/pub_link/Collateral/NCS5651-D.PDF.
- [4] ON Semiconductor, Roger Stout. Thermal considerations for the NCS5651 (application note AND8402/D), August 2014. Online at www.onsemi.com/pub_link/Collateral/AND8402-D.PDF.

ON Semiconductor and the ON Semiconductor logo are trademarks of Semiconductor Components Industries, LLC dba ON Semiconductor or its subsidiaries in the United States and/or other countries. ON Semiconductor owns the rights to a number of patents, trademarks, copyrights, trade secrets, and other intellectual property. A listing of ON Semiconductor's product/patent coverage may be accessed at www.onsemi.com/site/pdf/Patent-Marking.pdf. ON Semiconductor is an Equal Opportunity/Affirmative Action Employer. This literature is subject to all applicable copyright laws and is not for resale in any manner.

The evaluation board/kit (research and development board/kit) (hereinafter the "board") is not a finished product and is as such not available for sale to consumers. The board is only intended for research, development, demonstration and evaluation purposes and should as such only be used in laboratory/development areas by persons with an engineering/technical training and familiar with the risks associated with handling electrical/mechanical components, systems and subsystems. This person assumes full responsibility/liability for proper and safe handling. Any other use, resale or redistribution for any other purpose is strictly prohibited.

The board is delivered "AS IS" and without warranty of any kind including, but not limited to, that the board is production-worthy, that the functions contained in the board will meet your requirements, or that the operation of the board will be uninterrupted or error free. ON Semiconductor expressly disclaims all warranties, express, implied or otherwise, including without limitation, warranties of fitness for a particular purpose and non-infringement of intellectual property rights.

ON Semiconductor reserves the right to make changes without further notice to any board.

You are responsible for determining whether the board will be suitable for your intended use or application or will achieve your intended results. Prior to using or distributing any systems that have been evaluated, designed or tested using the board, you agree to test and validate your design to confirm the functionality for your application. Any technical, applications or design information or advice, quality characterization, reliability data or other services provided by ON Semiconductor shall not constitute any representation or warranty by ON Semiconductor, and no additional obligations or liabilities shall arise from ON Semiconductor having provided such information or services.

The boards are not designed, intended, or authorized for use in life support systems, or any FDA Class 3 medical devices or medical devices with a similar or equivalent classification in a foreign jurisdiction, or any devices intended for implantation in the human body. Should you purchase or use the board for any such unintended or unauthorized application, you shall indemnify and hold ON Semiconductor and its officers, employees, subsidiaries, affiliates, and distributors harmless against all claims, costs, damages, and expenses, and reasonable attorney fees arising out of, directly or indirectly, any claim of personal injury or death associated with such unintended or unauthorized use, even if such claim alleges that ON Semiconductor was negligent regarding the design or manufacture of the board.

This evaluation board/kit does not fall within the scope of the European Union directives regarding electromagnetic compatibility, restricted substances (RoHS), recycling (WEEE), FCC, CE or UL, and may not meet the technical requirements of these or other related directives.

FCC WARNING – This evaluation board/kit is intended for use for engineering development, demonstration, or evaluation purposes only and is not considered by ON Semiconductor to be a finished end product fit for general consumer use. It may generate, use, or radiate radio frequency energy and has not been tested for compliance with the limits of computing devices pursuant to part 15 of FCC rules, which are designed to provide reasonable protection against radio frequency interference. Operation of this equipment may cause interference with radio communications, in which case the user shall be responsible, at its expense, to take whatever measures may be required to correct this interference.

ON Semiconductor does not convey any license under its patent rights nor the rights of others.

LIMITATIONS OF LIABILITY: ON Semiconductor shall not be liable for any special, consequential, incidental, indirect or punitive damages, including, but not limited to the costs of requalification, delay, loss of profits or goodwill, arising out of or in connection with the board, even if ON Semiconductor is advised of the possibility of such damages. In no event shall ON Semiconductor's aggregate liability from any obligation arising out of or in connection with the board, under any theory of liability, exceed the purchase price paid for the board, if any.

For more information and documentation, please visit www.onsemi.com.

PUBLICATION ORDERING INFORMATION

LITERATURE FULFILLMENT:

Email Requests to: orderlit@onsemi.com

ON Semiconductor Website: www.onsemi.com

TECHNICAL SUPPORT

North American Technical Support:

Voice Mail: 1 800-282-9855 Toll Free USA/Canada

Phone: 011 421 33 790 2910

Europe, Middle East and Africa Technical Support:

Phone: 00421 33 790 2910

For additional information, please contact your local Sales Representative

