

Ambient Light Sensor, Linear Current Output, with 2-Stage Gain Switching

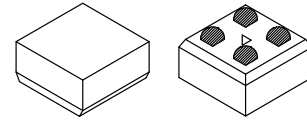

ODCSP4 1.01x1.01
 CASE 570AC

LA0151CS

Overview

The LA0151CS is a photo IC for ultra-small package ambient light sensor. It enables to be mounted on a very small limited space such as on the mobile phones which is becoming small and thinner and on other mobile applications.

Features

- Linear Current Output
- Low Gain Mode Function [Low Gain: -35 dB]

Typical Applications

- Mobile Phones and Tablets
- Digital Still Cameras
- Security Camera

SPECIFICATION

ABSOLUTE MAXIMUM RATINGS (at Ta = 25°C)

Parameter	Symbol	Conditions	Rating	Unit
Maximum Supply Voltage	V _{CC}		6	V
Operating Temperature	T _{opr}		-30 to +85	°C
Storage Temperature	T _{stg}		-40 to +100	°C

Stresses exceeding those listed in the Maximum Ratings table may damage the device. If any of these limits are exceeded, device functionality should not be assumed, damage may occur and reliability may be affected.

RECOMMENED OPERATING CONDITIONS AND OPERATING VOLTAGE RANGE (at Ta = 25°C)

Parameter	Symbol	Conditions	Rating			Unit
			Min	Typ	Max	
Recommended Supply Voltage	V _{CC}		2.2	3.3	5.5	V
SW Pin Low Voltage	V _l	Normal gain mode	0	-	0.4	V
SW Pin High Voltage	V _h	Low gain mode	2.1	-	-	V

Functional operation above the stresses listed in the Recommended Operating Ranges is not implied. Extended exposure to stresses beyond the Recommended Operating Ranges limits may affect device reliability.

ORDERING INFORMATION

Ordering Code	Package	Shipping [†]
LA0151CS-TLM-E	ODCSP4 (Pb-Free / Halogen Free)	5000 / Tape & Reel

[†]For information on tape and reel specifications, including part orientation and tape sizes, please refer to our Tape and Reel Packaging Specifications Brochure, BRD8011/D.

LA0151CS

ELECTRICAL CHARACTERISTICS (at $T_a = 25^\circ\text{C}$, $V_{CC} = 3.3\text{ V}$)

Parameter	Symbol	Conditions	Ratings			Unit
			Min	Typ	Max	
Current Dissipation (1) (Note 2, 4)	I_{CC}	$E_v = 1000\text{ lx}$, $R_L = 5\text{ k}\Omega$, N mode	90	150	210	μA
Current Dissipation (2) (Note 2, 4)	I_{CC}	$E_v = 1000\text{ lx}$, $R_L = 5\text{ k}\Omega$, L mode	42	70	98	μA
Output Current (1) (Note 2, 4)	I_{O1}	$E_v = 100\text{ lx}$, N mode	6	8	10	μA
Output Current (2) (Note 2, 4)	I_{O2}	$E_v = 1000\text{ lx}$, N mode	60	80	100	μA
Output Current (3) (Note 2, 4)	I_{O3}	$E_v = 100\text{ lx}$, L mode	0.12	0.16	0.2	μA
Output Current (4) (Note 2, 4)	I_{O4}	$E_v = 1000\text{ lx}$, L mode	1.2	1.6	2.0	μA
Dark Current	I_{leak}	$E_v = 0\text{ lx}$, N mode, L mode	-	-	0.1	μA
Temperature Coefficient (Note 3)	I_{tc}	$E_v = 100\text{ lx}$, N mode, L mode, $T_a = -20\text{ to }60^\circ\text{C}$	-	0.34	-	$\%/^\circ\text{C}$
Rise Time (1) (Note 5)	T_{r1}	$E_v = 1000\text{ lx}$, $R_L = 5\text{ k}\Omega$, N mode	-	15	40	μs
Rise Time (2) (Note 5)	T_{r2}	$E_v = 1000\text{ lx}$, $R_L = 500\text{ k}\Omega$, L mode	-	20	50	μs
Fall Time (1) (Note 5)	T_{f1}	$E_v = 1000\text{ lx}$, $R_L = 5\text{ k}\Omega$, N mode	-	150	500	μs
Fall Time (2) (Note 5)	T_{f2}	$E_v = 1000\text{ lx}$, $R_L = 500\text{ k}\Omega$, L mode	-	150	500	μs
Peak Sensitivity Wave Length (Note 3)	λ_p		-	550	-	nm
Saturation Output Voltage (Note 6)	V_O	$E_v = 1000\text{ lx}$, $R_L = 150\text{ k}\Omega$, N mode	3.0	3.2	-	V

Product parametric performance is indicated in the Electrical Characteristics for the listed test conditions, unless otherwise noted. Product performance may not be indicated by the Electrical Characteristics if operated under different conditions.

1. N mode and L mode stand for the normal gain mode and the low gain mode, respectively.
2. Measured with the standard light source A. White LED is used instead in the mass production line.
3. Design guaranteed item
4. Test circuit for measuring current dissipation and output current

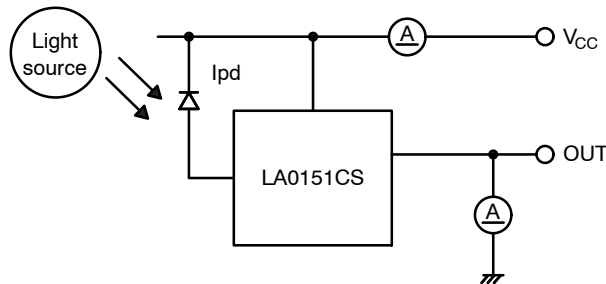

Figure 1.

5. Measuring method of rise time (T_r) and fall time (T_f)

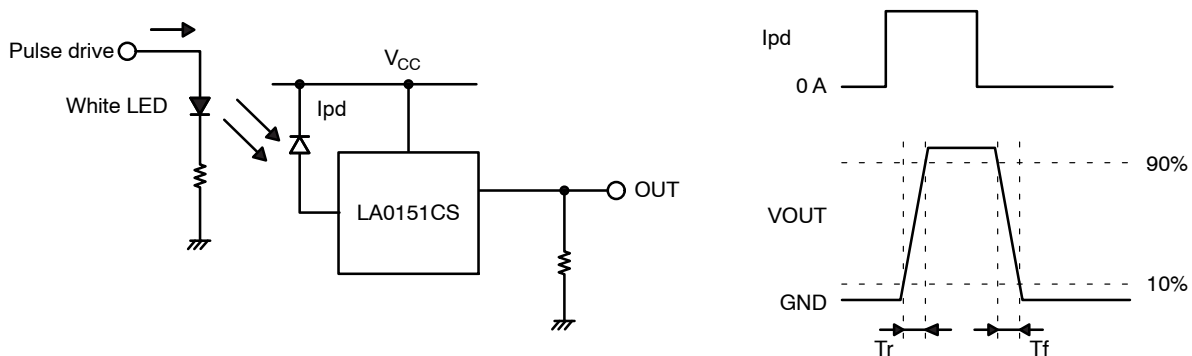

Figure 2.

6. Reference value: min = 2.6 V and typ = 2.8 V when $V_{CC} = 2.9\text{ V}$

LA0151CS

PAD LAYOUT

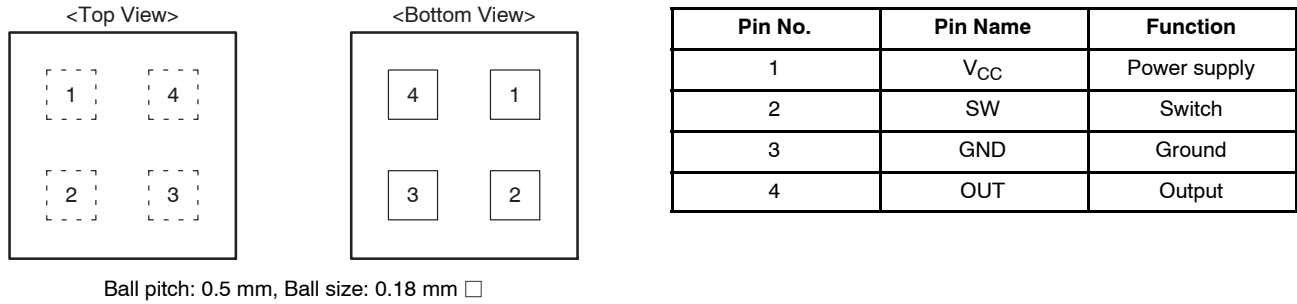
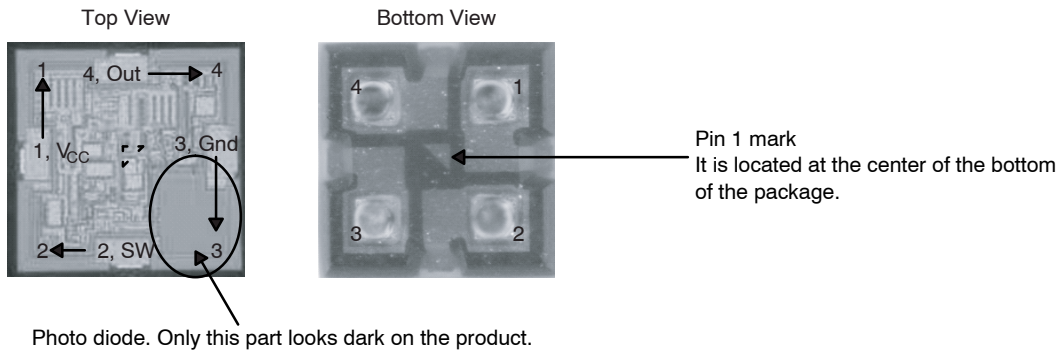

Figure 3. Pad Layout

PAD LAYOUT (Photos)



*The photo diode is located in pin 3. Be careful not to mistake the pin 1 mark for the photo diode.

Figure 4. Pad Layout (Photos)

INTERNAL BLOCK DIAGRAM

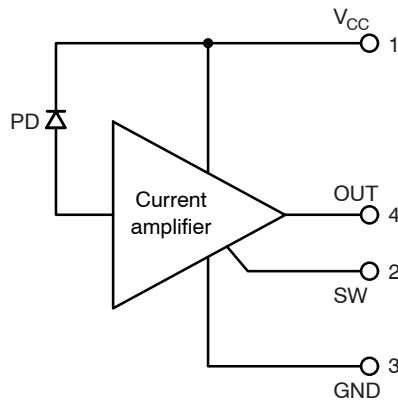

Figure 5. Internal Block Diagram

LA0151CS

CHIP PATTERN AND PHOTO-RECEIVING PATTERN DIAGRAMS

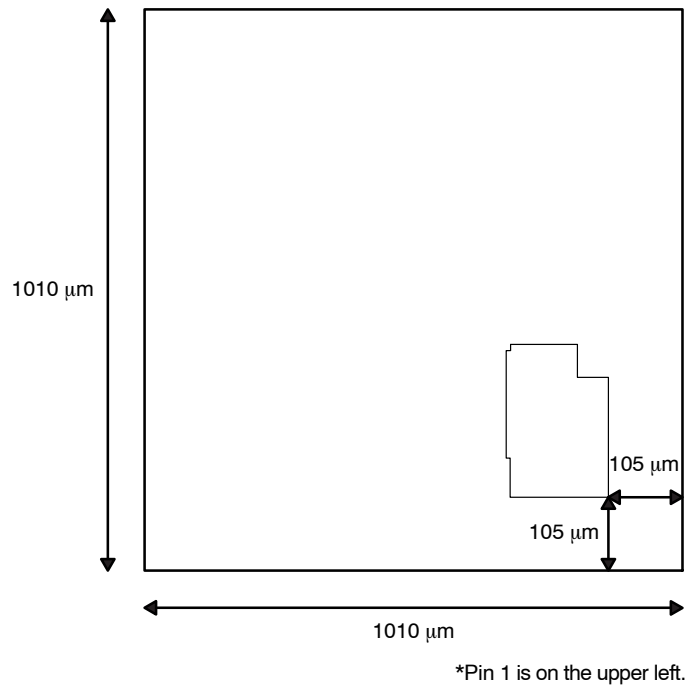

Figure 6. LA0151CS Chip Pattern Diagram (Top View)

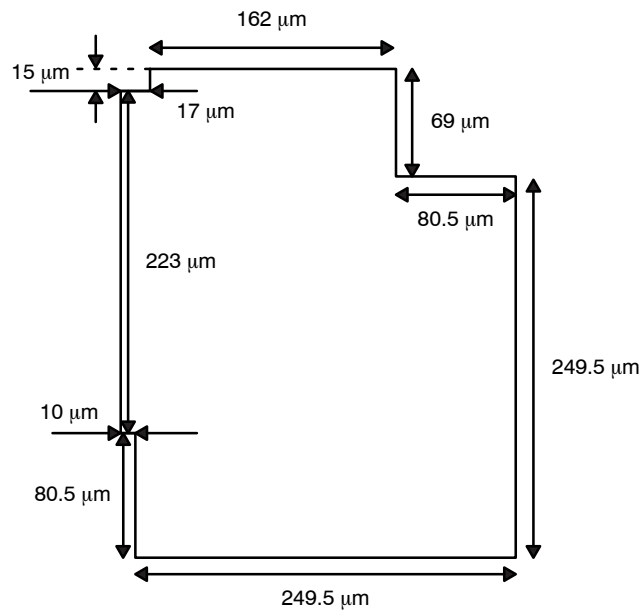

Figure 7. LA0151CS Photo-receiving Pattern Enlarged Diagram (Effective Area)

LA0151CS

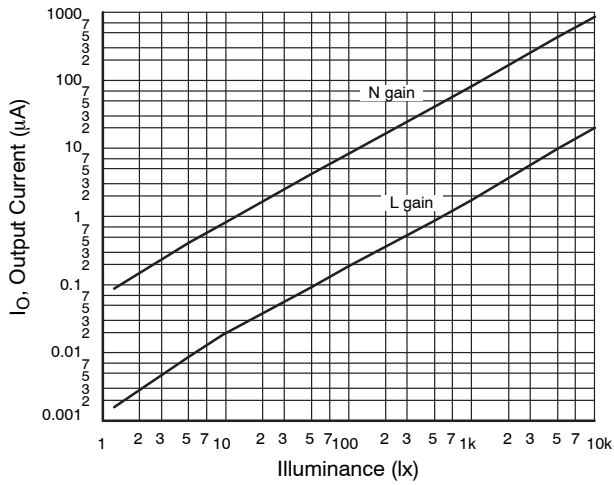

Figure 8. I_O - Illuminance

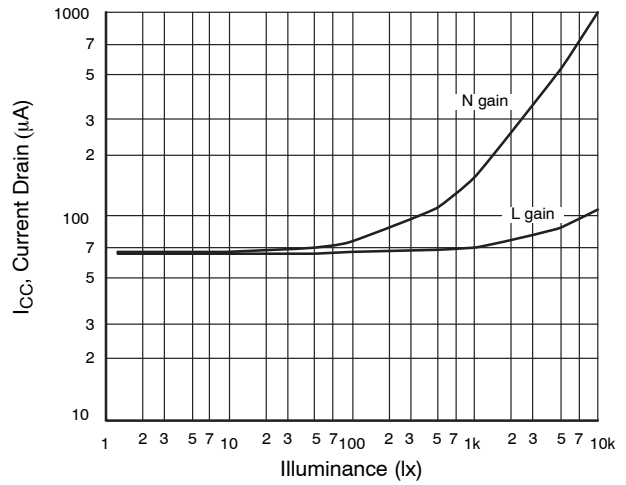

Figure 9. I_{CC} - Illuminance

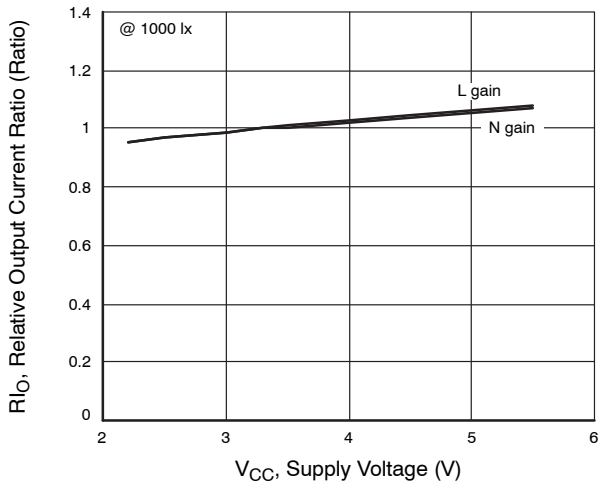

Figure 10. R_{I_O} - V_{CC}

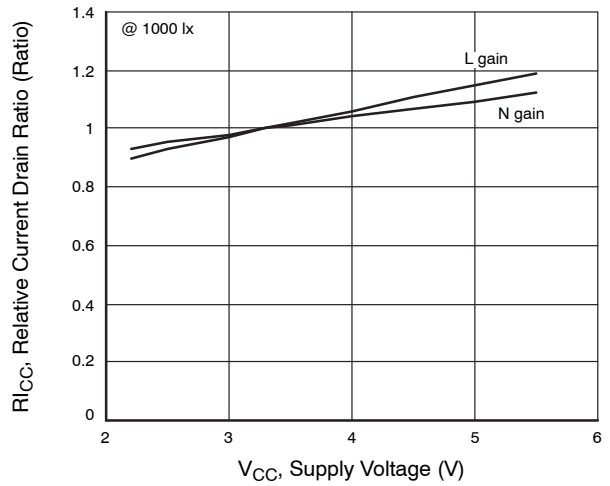

Figure 11. $R_{I_{CC}}$ - V_{CC}

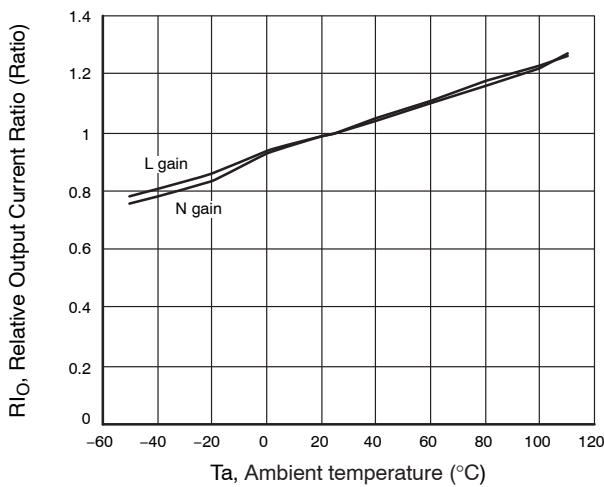

Figure 12. R_{I_O} - T_a

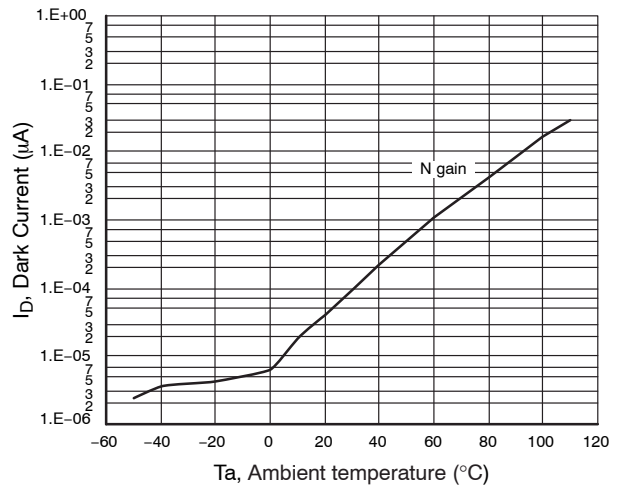

Figure 13. I_D - T_a

LA0151CS

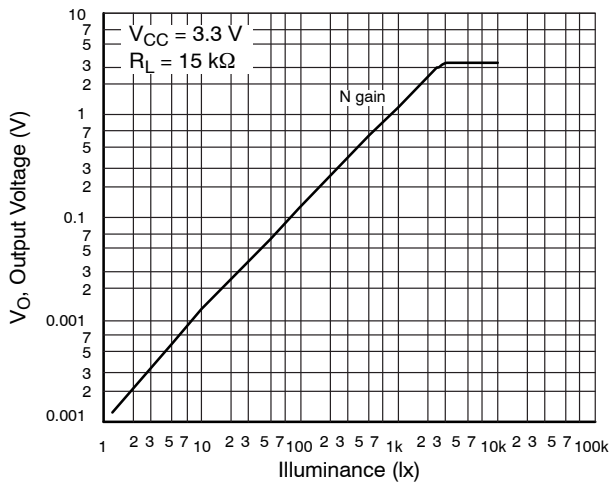

Figure 14. V_O – Illuminance

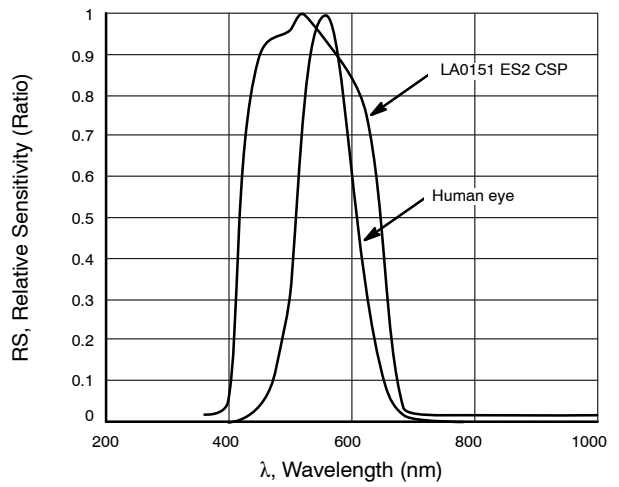

Figure 15. RS – λ

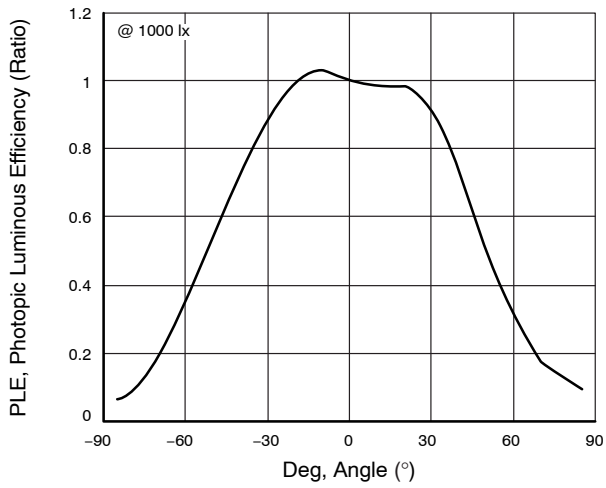

Figure 16. PLE – Deg N Gain

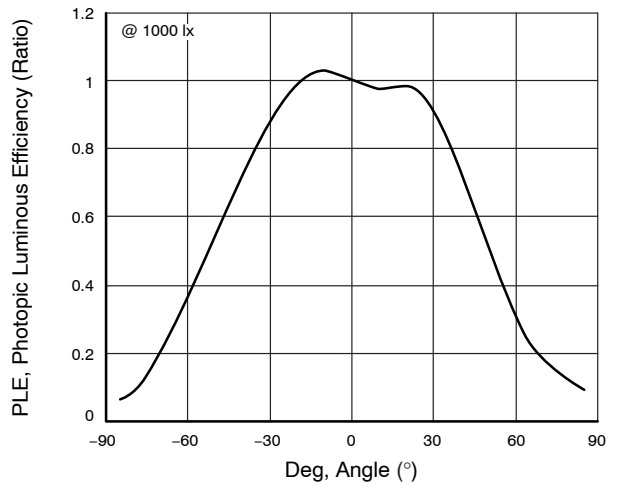
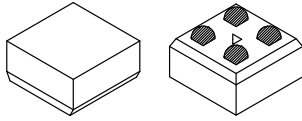

Figure 17. PLE – Deg L Gain

MECHANICAL CASE OUTLINE

PACKAGE DIMENSIONS

ON Semiconductor®



ODCSP4 1.01x1.01
CASE 570AC
ISSUE O

DATE 31 MAR 2012

TOP VIEW

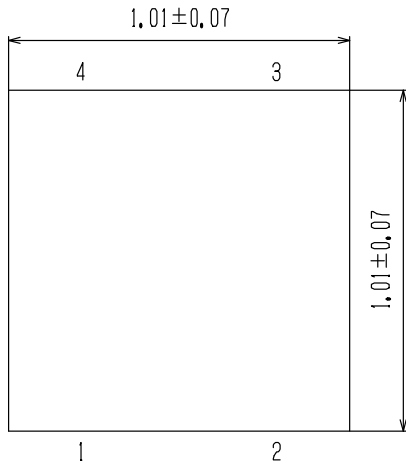

SIDE VIEW

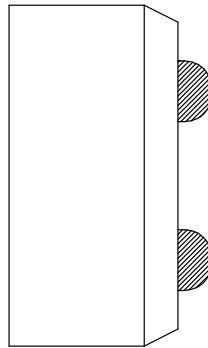

BOTTOM VIEW

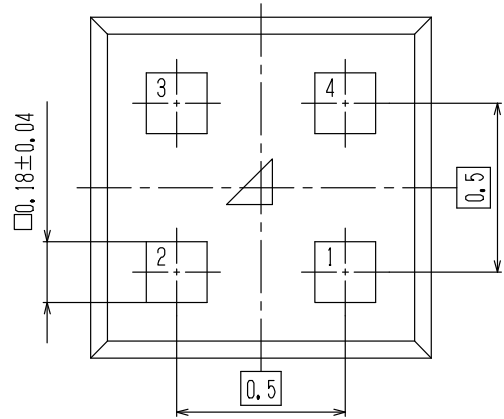

SIDE VIEW

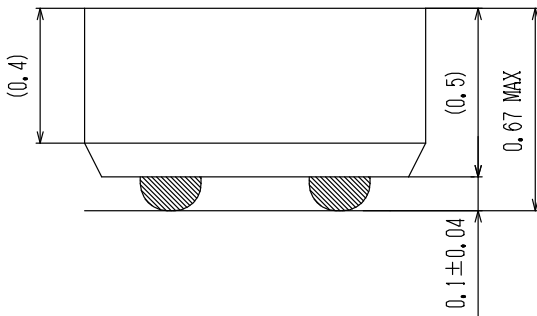

DOCUMENT NUMBER:	98AON78694E	Electronic versions are uncontrolled except when accessed directly from the Document Repository. Printed versions are uncontrolled except when stamped "CONTROLLED COPY" in red.
DESCRIPTION:	ODCSP4 1.01X1.01	PAGE 1 OF 1

ON Semiconductor and are trademarks of Semiconductor Components Industries, LLC dba ON Semiconductor or its subsidiaries in the United States and/or other countries. ON Semiconductor reserves the right to make changes without further notice to any products herein. ON Semiconductor makes no warranty, representation or guarantee regarding the suitability of its products for any particular purpose, nor does ON Semiconductor assume any liability arising out of the application or use of any product or circuit, and specifically disclaims any and all liability, including without limitation special, consequential or incidental damages. ON Semiconductor does not convey any license under its patent rights nor the rights of others.

onsemi, **Onsemi**, and other names, marks, and brands are registered and/or common law trademarks of Semiconductor Components Industries, LLC dba "**onsemi**" or its affiliates and/or subsidiaries in the United States and/or other countries. **onsemi** owns the rights to a number of patents, trademarks, copyrights, trade secrets, and other intellectual property. A listing of **onsemi**'s product/patent coverage may be accessed at www.onsemi.com/site/pdf/Patent-Marking.pdf. **onsemi** reserves the right to make changes at any time to any products or information herein, without notice. The information herein is provided "as-is" and **onsemi** makes no warranty, representation or guarantee regarding the accuracy of the information, product features, availability, functionality, or suitability of its products for any particular purpose, nor does **onsemi** assume any liability arising out of the application or use of any product or circuit, and specifically disclaims any and all liability, including without limitation special, consequential or incidental damages. Buyer is responsible for its products and applications using **onsemi** products, including compliance with all laws, regulations and safety requirements or standards, regardless of any support or applications information provided by **onsemi**. "Typical" parameters which may be provided in **onsemi** data sheets and/or specifications can and do vary in different applications and actual performance may vary over time. All operating parameters, including "Typicals" must be validated for each customer application by customer's technical experts. **onsemi** does not convey any license under any of its intellectual property rights nor the rights of others. **onsemi** products are not designed, intended, or authorized for use as a critical component in life support systems or any FDA Class 3 medical devices or medical devices with a same or similar classification in a foreign jurisdiction or any devices intended for implantation in the human body. Should Buyer purchase or use **onsemi** products for any such unintended or unauthorized application, Buyer shall indemnify and hold **onsemi** and its officers, employees, subsidiaries, affiliates, and distributors harmless against all claims, costs, damages, and expenses, and reasonable attorney fees arising out of, directly or indirectly, any claim of personal injury or death associated with such unintended or unauthorized use, even if such claim alleges that **onsemi** was negligent regarding the design or manufacture of the part. **onsemi** is an Equal Opportunity/Affirmative Action Employer. This literature is subject to all applicable copyright laws and is not for resale in any manner.

PUBLICATION ORDERING INFORMATION

LITERATURE FULFILLMENT:

Email Requests to: orderlit@onsemi.com

onsemi Website: www.onsemi.com

TECHNICAL SUPPORT

North American Technical Support:

Voice Mail: 1 800-282-9855 Toll Free USA/Canada

Phone: 011 421 33 790 2910

Europe, Middle East and Africa Technical Support:

Phone: 00421 33 790 2910

For additional information, please contact your local Sales Representative

