

# MC1455, MC1455B, NCV1455B

## Timers

The MC1455 monolithic timing circuit is a highly stable controller capable of producing accurate time delays or oscillation. Additional terminals are provided for triggering or resetting if desired. In the time delay mode, time is precisely controlled by one external resistor and capacitor. For astable operation as an oscillator, the free-running frequency and the duty cycle are both accurately controlled with two external resistors and one capacitor. The circuit may be triggered and reset on falling waveforms, and the output structure can source or sink up to 200 mA or drive TTL circuits.

### Features

- Direct Replacement for NE555 Timers
- Timing from Microseconds through Hours
- Operates in Both Astable and Monostable Modes
- Adjustable Duty Cycle
- High Current Output Can Source or Sink 200 mA
- Output Can Drive TTL
- Temperature Stability of 0.005% per °C
- Normally ON or Normally OFF Output
- Pb-Free Packages are Available

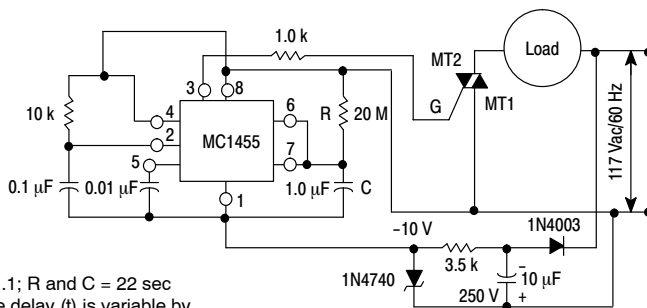

$t = 1.1; R \text{ and } C = 22 \text{ sec}$   
Time delay ( $t$ ) is variable by changing  $R$  and  $C$  (see Figure 16).

Figure 1.22 Second Solid State Time Delay Relay Circuit

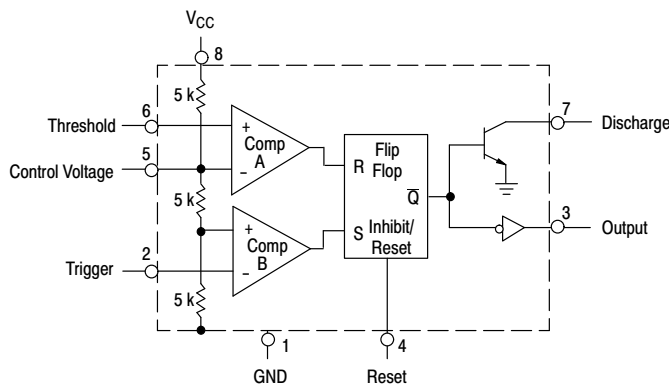

Figure 2. Representative Block Diagram



ON Semiconductor®

<http://onsemi.com>

### MARKING DIAGRAMS

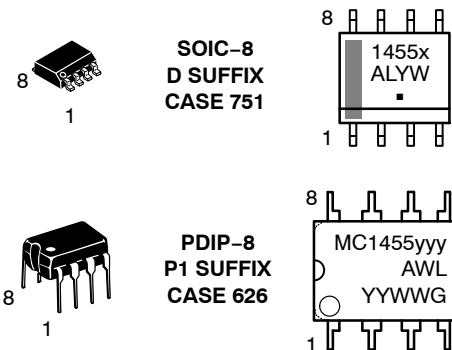

x = B or V  
yyy = BP1 or P1  
A = Assembly Location  
L = Wafer Lot  
Y, YY = Year  
W, WW = Work Week  
▪ or G = Pb-Free Package

### ORDERING INFORMATION

See detailed ordering and shipping information in the package dimensions section on page 9 of this data sheet.

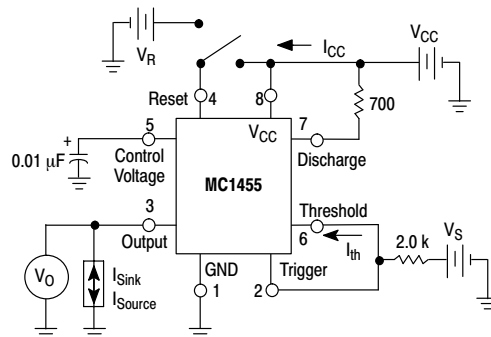

Test circuit for measuring DC parameters (to set output and measure parameters):

- When  $V_S \geq 2/3 V_{CC}$ ,  $V_O$  is low.
- When  $V_S \leq 1/3 V_{CC}$ ,  $V_O$  is high.
- When  $V_O$  is low, Pin 7 sinks current. To test for Reset, set  $V_O$  high, apply Reset voltage, and test for current flowing into Pin 7. When Reset is not in use, it should be tied to  $V_{CC}$ .

Figure 3. General Test Circuit

# MC1455, MC1455B, NCV1455B

## MAXIMUM RATINGS ( $T_A = +25^\circ\text{C}$ , unless otherwise noted.)

Rating	Symbol	Value	Unit
Power Supply Voltage	$V_{CC}$	+18	Vdc
Discharge Current (Pin 7)	$I_7$	200	mA
Power Dissipation (Package Limitation) P1 Suffix, Plastic Package Derate above $T_A = +25^\circ\text{C}$	$P_D$	625	mW
D Suffix, Plastic Package Derate above $T_A = +25^\circ\text{C}$	$P_D$	5.0 625 160	mW/ $^\circ\text{C}$ mW $^\circ\text{C}/\text{W}$
Operating Temperature Range (Ambient) MC1455B MC1455 NCV1455B	$T_A$	-40 to +85 0 to +70 -40 to +125	$^\circ\text{C}$
Maximum Operating Die Junction Temperature	$T_J$	+150	$^\circ\text{C}$
Storage Temperature Range	$T_{stg}$	-65 to +150	$^\circ\text{C}$

Stresses exceeding Maximum Ratings may damage the device. Maximum Ratings are stress ratings only. Functional operation above the Recommended Operating Conditions is not implied. Extended exposure to stresses above the Recommended Operating Conditions may affect device reliability.

## ELECTRICAL CHARACTERISTICS ( $T_A = +25^\circ\text{C}$ , $V_{CC} = +5.0\text{ V}$ to $+15\text{ V}$ , unless otherwise noted.)

Characteristics	Symbol	Min	Typ	Max	Unit
Operating Supply Voltage Range	$V_{CC}$	4.5	-	16	V
Supply Current $V_{CC} = 5.0\text{ V}$ , $R_L = \infty$ $V_{CC} = 15\text{ V}$ , $R_L = \infty$ , Low State (Note 1)	$I_{CC}$	-	3.0 10	6.0 15	mA
Timing Error ( $R = 1.0\text{ k}\Omega$ to $100\text{ k}\Omega$ ) (Note 2) Initial Accuracy $C = 0.1\text{ }\mu\text{F}$ Drift with Temperature Drift with Supply Voltage		-	1.0 50 0.1	-	% PPM/ $^\circ\text{C}$ %/V
Threshold Voltage/Supply Voltage	$V_{th}/V_{CC}$	-	2/3	-	
Trigger Voltage $V_{CC} = 15\text{ V}$ $V_{CC} = 5.0\text{ V}$	$V_T$	-	5.0 1.67	-	V
Trigger Current	$I_T$	-	0.5	-	$\mu\text{A}$
Reset Voltage	$V_R$	0.4	0.7	1.0	V
Reset Current	$I_R$	-	0.1	-	mA
Threshold Current (Note 3)	$I_{th}$	-	0.1	0.25	$\mu\text{A}$
Discharge Leakage Current (Pin 7)	$I_{dischg}$	-	-	100	nA
Control Voltage Level $V_{CC} = 15\text{ V}$ $V_{CC} = 5.0\text{ V}$	$V_{CL}$	9.0 2.6	10 3.33	11 4.0	V
Output Voltage Low $I_{Sink} = 10\text{ mA}$ ( $V_{CC} = 15\text{ V}$ ) $I_{Sink} = 50\text{ mA}$ ( $V_{CC} = 15\text{ V}$ ) $I_{Sink} = 100\text{ mA}$ ( $V_{CC} = 15\text{ V}$ ) $I_{Sink} = 200\text{ mA}$ ( $V_{CC} = 15\text{ V}$ ) $I_{Sink} = 8.0\text{ mA}$ ( $V_{CC} = 5.0\text{ V}$ ) $I_{Sink} = 5.0\text{ mA}$ ( $V_{CC} = 5.0\text{ V}$ )	$V_{OL}$	-	0.1 0.4 2.0 2.5 -	0.25 0.75 2.5 -	V
Output Voltage High $V_{CC} = 15\text{ V}$ ( $I_{Source} = 200\text{ mA}$ ) $V_{CC} = 15\text{ V}$ ( $I_{Source} = 100\text{ mA}$ ) $V_{CC} = 5.0\text{ V}$ ( $I_{Source} = 100\text{ mA}$ )	$V_{OH}$	- 12.75 2.75	12.5 13.3 3.3	- -	V
Rise Time Differential Output	$t_r$	-	100	-	ns
Fall Time Differential Output	$t_f$	-	100	-	ns

- Supply current when output is high is typically 1.0 mA less.
- Tested at  $V_{CC} = 5.0\text{ V}$  and  $V_{CC} = 15\text{ V}$  Monostable mode.
- This will determine the maximum value of  $R_A + R_B$  for 15 V operation. The maximum total  $R = 20\text{ M}\Omega$ .
- $T_{low} = 0^\circ\text{C}$  for MC1455,  $T_{low} = -40^\circ\text{C}$  for MC1455B, NCV1455B  
 $T_{high} = +70^\circ\text{C}$  for MC1455,  $T_{high} = +85^\circ\text{C}$  for MC1455B,  $T_{high} = +125^\circ\text{C}$  for NCV1455B
- NCV prefix is for Automotive and other applications requiring site and change control.

# MC1455, MC1455B, NCV1455B

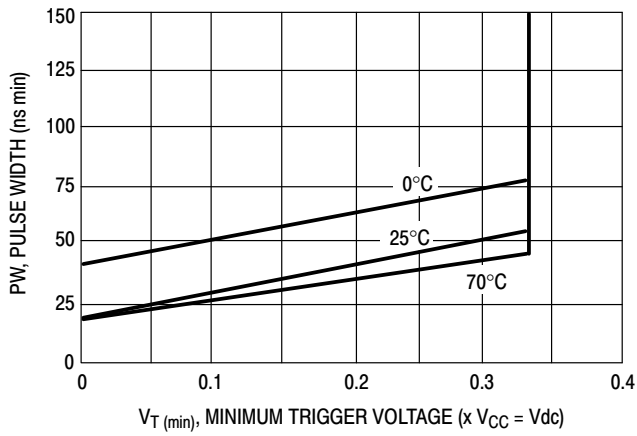

Figure 4. Trigger Pulse Width

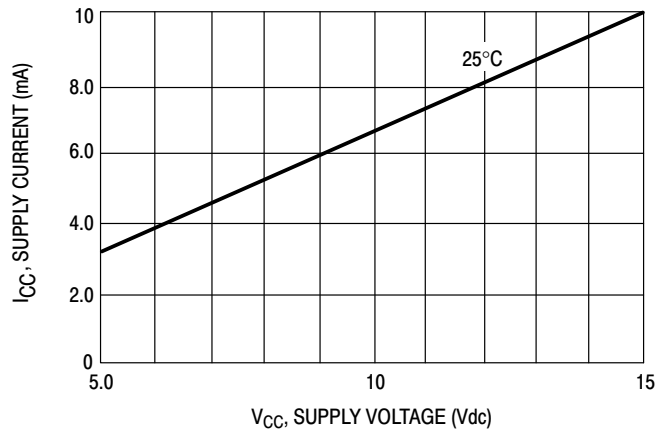

Figure 5. Supply Current

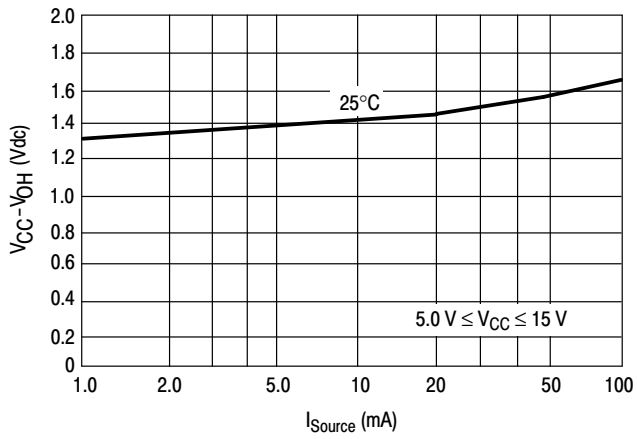

Figure 6. High Output Voltage

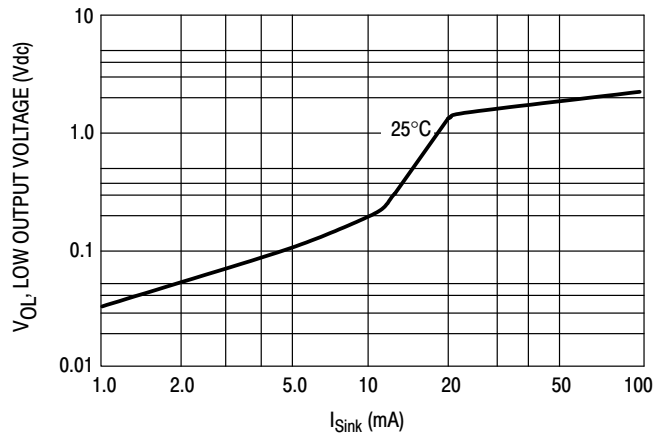

Figure 7. Low Output Voltage @  $V_{CC} = 5.0$  V<sub>dc</sub>

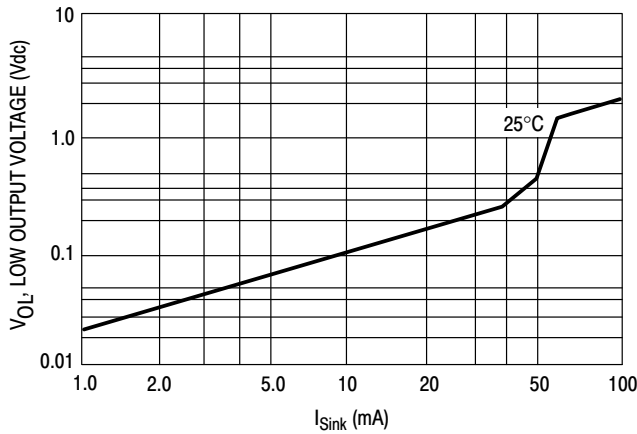

Figure 8. Low Output Voltage @  $V_{CC} = 10$  V<sub>dc</sub>

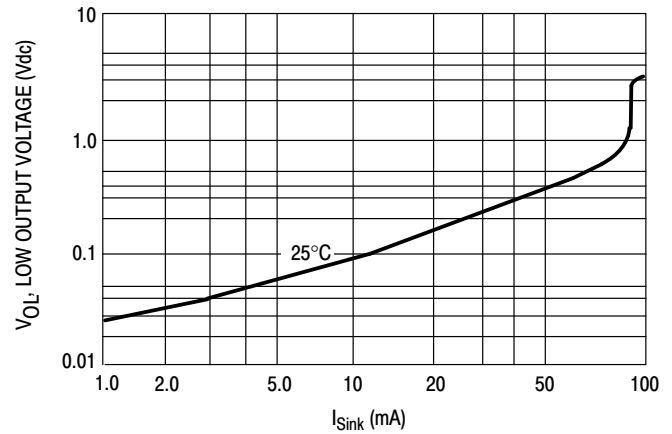

Figure 9. Low Output Voltage @  $V_{CC} = 15$  V<sub>dc</sub>

# MC1455, MC1455B, NCV1455B

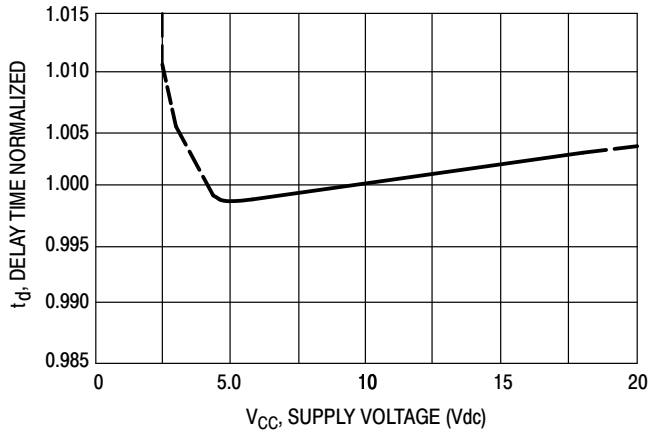

Figure 10. Delay Time versus Supply Voltage

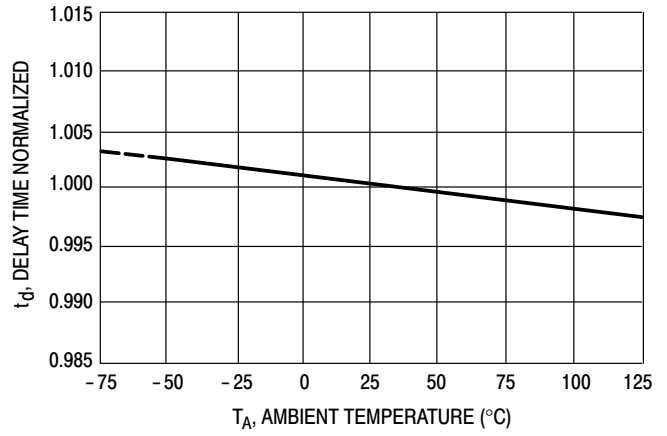

Figure 11. Delay Time versus Temperature

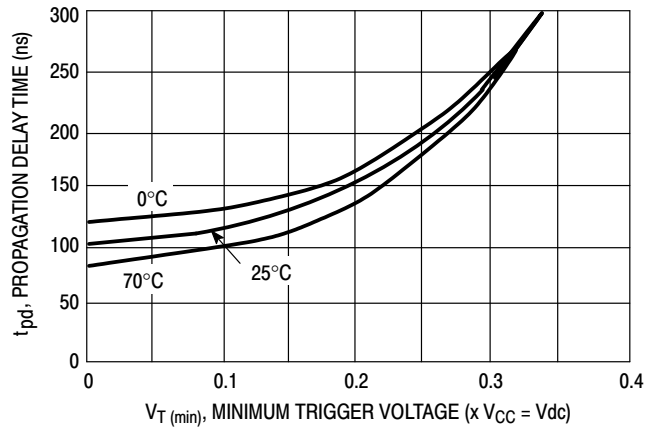

Figure 12. Propagation Delay versus Trigger Voltage

# MC1455, MC1455B, NCV1455B

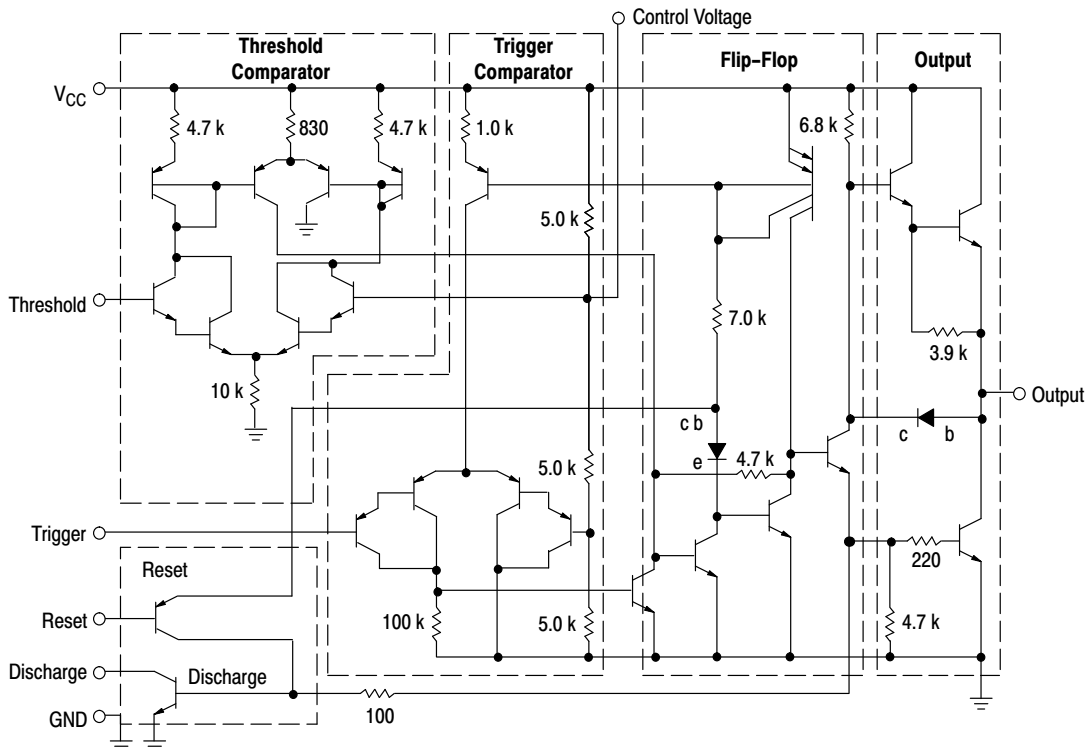

Figure 13. Representative Circuit Schematic

## GENERAL OPERATION

The MC1455 is a monolithic timing circuit which uses an external resistor – capacitor network as its timing element. It can be used in both the monostable (one-shot) and astable modes with frequency and duty cycle controlled by the capacitor and resistor values. While the timing is dependent upon the external passive components, the monolithic circuit provides the starting circuit, voltage comparison and other functions needed for a complete timing circuit. Internal to the integrated circuit are two comparators, one for the input signal and the other for capacitor voltage; also a flip-flop and digital output are included. The comparator reference voltages are always a fixed ratio of the supply voltage thus providing output timing independent of supply voltage.

### Monostable Mode

In the monostable mode, a capacitor and a single resistor are used for the timing network. Both the threshold terminal and the discharge transistor terminal are connected together in this mode (refer to circuit in Figure 14). When the input voltage to the trigger comparator falls below  $1/3 V_{CC}$ , the comparator output triggers the flip-flop so that its output sets low. This turns the capacitor discharge transistor “off” and drives the digital output to the high state. This condition allows the capacitor to charge at an exponential rate which is set by the RC time constant. When the capacitor voltage reaches  $2/3 V_{CC}$ , the threshold comparator resets the flip-flop. This action discharges the timing capacitor and returns the digital output to the low state. Once the flip-flop

has been triggered by an input signal, it cannot be retriggered until the present timing period has been completed. The time that the output is high is given by the equation  $t = 1.1 R_A C$ . Various combinations of R and C and their associated times are shown in Figure 16. The trigger pulse width must be less than the timing period.

A reset pin is provided to discharge the capacitor, thus interrupting the timing cycle. As long as the reset pin is low, the capacitor discharge transistor is turned “on” and prevents the capacitor from charging. While the reset voltage is applied the digital output will remain the same. The reset pin should be tied to the supply voltage when not in use.

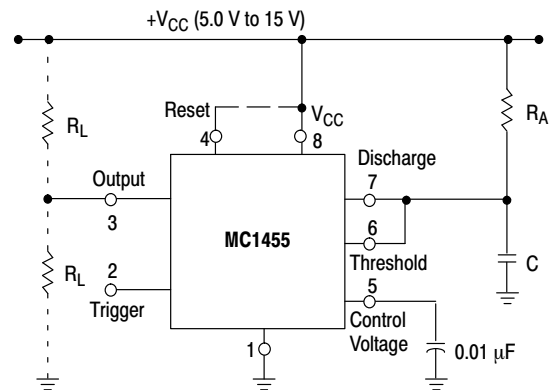

Figure 14. Monostable Circuit



Figure 15. Monostable Waveforms

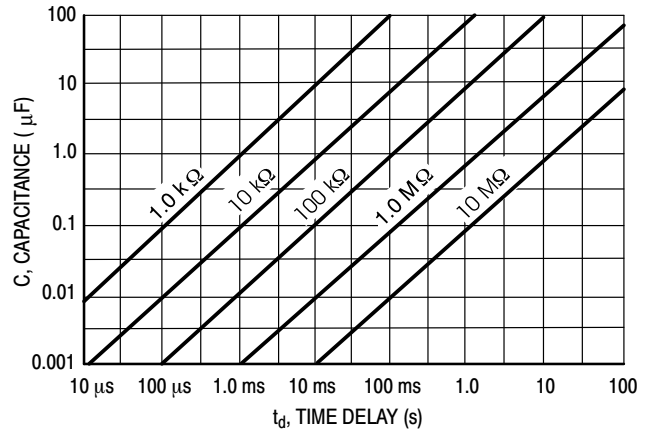

Figure 16. Time Delay

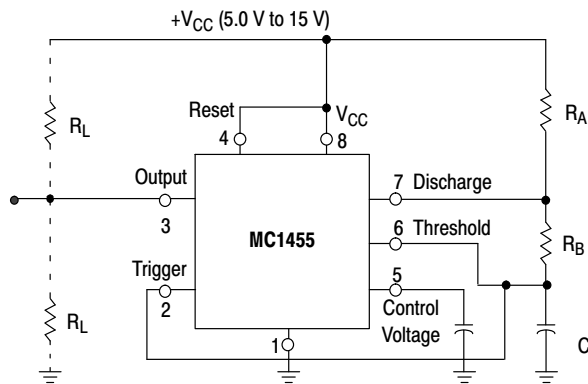

Figure 17. Astable Circuit

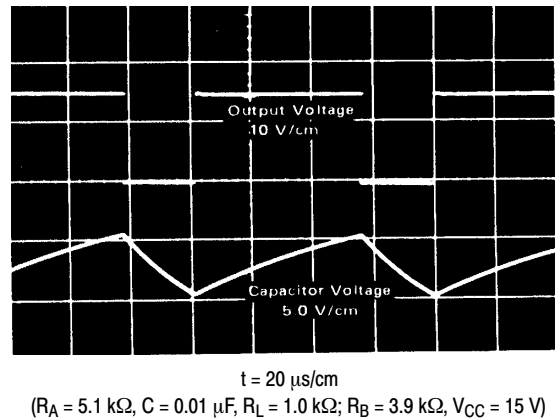

Figure 18. Astable Waveforms

**Astable Mode**

In the astable mode the timer is connected so that it will retrigger itself and cause the capacitor voltage to oscillate between 1/3 V<sub>CC</sub> and 2/3 V<sub>CC</sub>. See Figure 17.

The external capacitor charges to 2/3 V<sub>CC</sub> through R<sub>A</sub> and R<sub>B</sub> and discharges to 1/3 V<sub>CC</sub> through R<sub>B</sub>. By varying the ratio of these resistors the duty cycle can be varied. The charge and discharge times are independent of the supply voltage.

The charge time (output high) is given by:

$$t_1 = 0.695 (R_A + R_B) C$$

The discharge time (output low) is given by:

$$t_2 = 0.695 (R_B) C$$

Thus the total period is given by:

$$T = t_1 + t_2 = 0.695 (R_A + 2R_B) C$$

The frequency of oscillation is then:

$$f = \frac{1}{T} = \frac{1.44}{(R_A + 2R_B) C}$$

and may be easily found as shown in Figure 19.

The duty cycle is given by: 
$$DC = \frac{R_B}{R_A + 2R_B}$$

To obtain the maximum duty cycle R<sub>A</sub> must be as small as possible; but it must also be large enough to limit the discharge current (Pin 7 current) within the maximum rating of the discharge transistor (200 mA).

The minimum value of R<sub>A</sub> is given by:

$$R_A \geq \frac{V_{CC}(V_{dc})}{17 (A)} \geq \frac{V_{CC}(V_{dc})}{0.2}$$

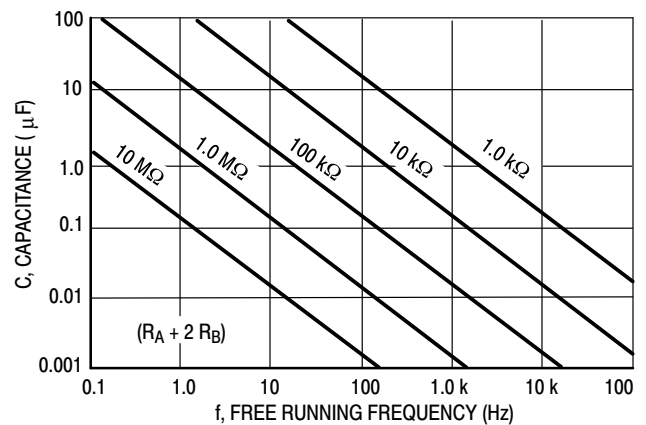

Figure 19. Free Running Frequency

APPLICATIONS INFORMATION

Linear Voltage Ramp

In the monostable mode, the resistor can be replaced by a constant current source to provide a linear ramp voltage. The capacitor still charges from 0  $V_{CC}$  to  $2/3 V_{CC}$ . The linear ramp time is given by:

$$t = \frac{2}{3} \frac{V_{CC}}{I}, \text{ where } I = \frac{V_{CC} - V_B - V_{BE}}{R_E}$$

If  $V_B$  is much larger than  $V_{BE}$ , then  $t$  can be made independent of  $V_{CC}$ .

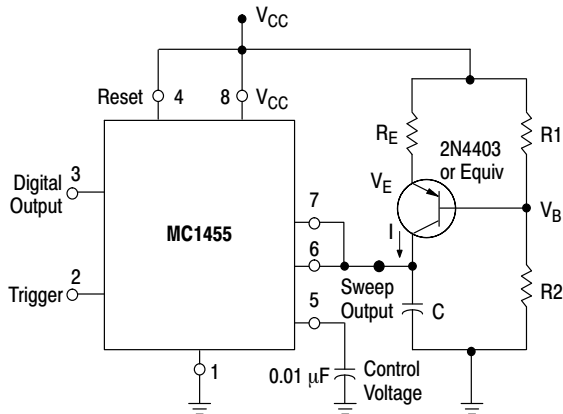

Figure 20. Linear Voltage Sweep Circuit

Missing Pulse Detector

The timer can be used to produce an output when an input pulse fails to occur within the delay of the timer. To accomplish this, set the time delay to be slightly longer than the time between successive input pulses. The timing cycle is then continuously reset by the input pulse train until a change in frequency or a missing pulse allows completion of the timing cycle, causing a change in the output level.

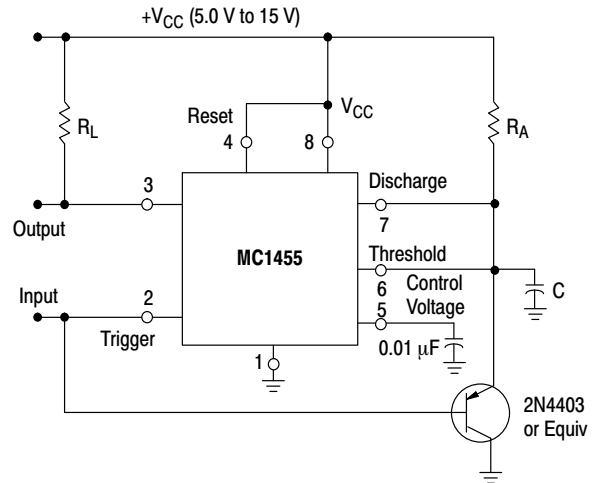
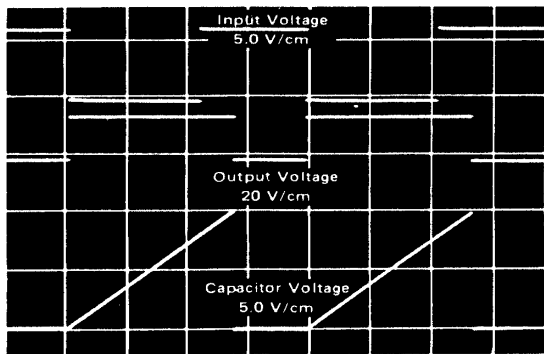

Figure 21. Missing Pulse Detector



$t = 100 \mu\text{s/cm}$

( $R_E = 10 \text{ k}\Omega$ ,  $R_2 = 100 \text{ k}\Omega$ ,  $R_1 = 39 \text{ k}\Omega$ ,  $C = 0.01 \mu\text{F}$ ,  $V_{CC} = 15 \text{ V}$ )

Figure 22. Linear Voltage Ramp Waveforms

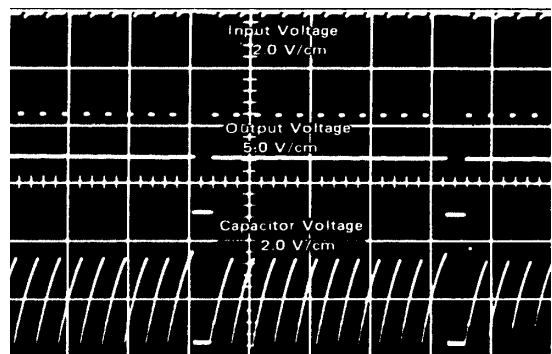

$t = 500 \mu\text{s/cm}$

( $R_A = 2.0 \text{ k}\Omega$ ,  $R_L = 1.0 \text{ k}\Omega$ ,  $C = 0.01 \mu\text{F}$ ,  $V_{CC} = 15 \text{ V}$ )

Figure 23. Missing Pulse Detector Waveforms

**Pulse Width Modulation**

If the timer is triggered with a continuous pulse train in the monostable mode of operation, the charge time of the capacitor can be varied by changing the control voltage at Pin 5. In this manner, the output pulse width can be modulated by applying a modulating signal that controls the threshold voltage.

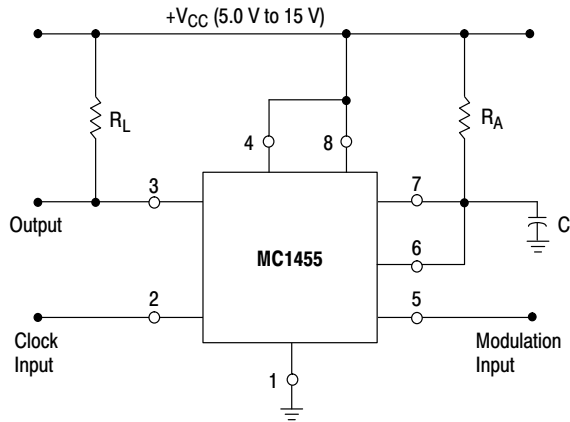

**Figure 24. Pulse Width Modulator**

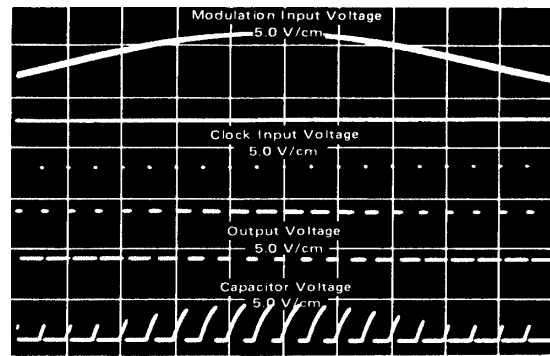

$t = 0.5 \text{ ms/cm}$   
 $(R_A = 10 \text{ k}\Omega, C = 0.02 \text{ }\mu\text{F}, V_{CC} = 15 \text{ V})$

**Figure 25. Pulse Width Modulation Waveforms**

**Test Sequences**

Several timers can be connected to drive each other for sequential timing. An example is shown in Figure 26 where the sequence is started by triggering the first timer which runs for 10 ms. The output then switches low momentarily and starts the second timer which runs for 50 ms and so forth.

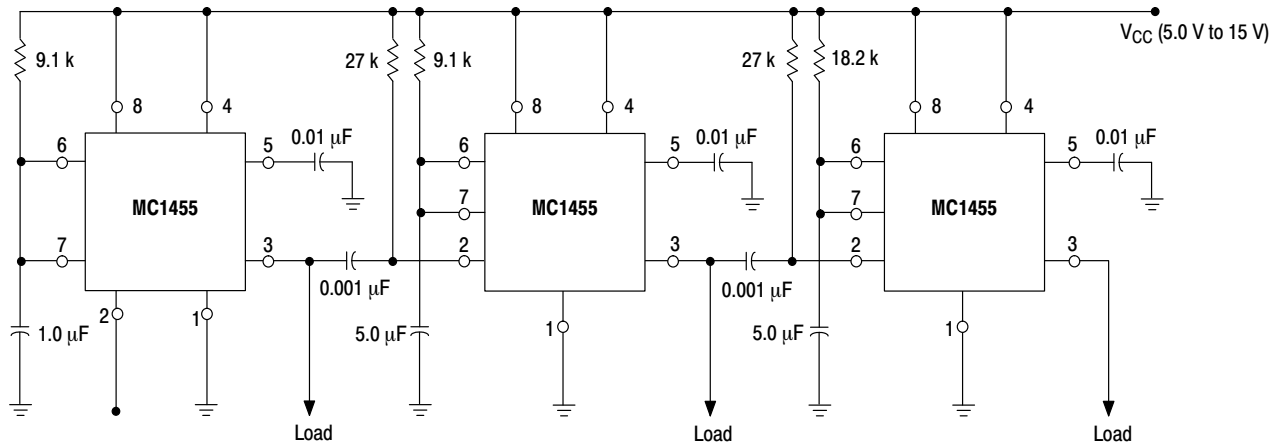

**Figure 26. Sequential Timer**



## MC1455, MC1455B, NCV1455B

### ORDERING INFORMATION

Device	Operating Temperature Range	Package	Shipping†
MC1455P1	$T_A = 0^{\circ}\text{C to } +70^{\circ}\text{C}$	PDIP-8	50 Units / Rail
MC1455P1G		PDIP-8 (Pb-Free)	50 Units / Rail
MC1455D		SOIC-8	98 Units / Rail
MC1455DG		SOIC-8 (Pb-Free)	98 Units / Rail
MC1455DR2		SOIC-8	2500 Units / Tape & Reel
MC1455DR2G		SOIC-8 (Pb-Free)	2500 Units / Tape & Reel
MC1455BD	$T_A = -40^{\circ}\text{C to } +85^{\circ}\text{C}$	SOIC-8	98 Units / Rail
MC1455BDG		SOIC-8 (Pb-Free)	98 Units / Rail
MC1455BDR2		SOIC-8	2500 Units / Tape & Reel
MC1455BDR2G		SOIC-8 (Pb-Free)	2500 Units / Tape & Reel
MC1455BP1		PDIP-8	50 Units / Rail
MC1455BP1G		PDIP-8 (Pb-Free)	50 Units / Rail
NCV1455BDR2*	$T_A = -40^{\circ}\text{C to } +125^{\circ}\text{C}$	SOIC-8	2500 Units / Tape & Reel
NCV1455BDR2G*		SOIC-8 (Pb-Free)	2500 Units / Tape & Reel

†For information on tape and reel specifications, including part orientation and tape sizes, please refer to our Tape and Reel Packaging Specifications Brochure, BRD8011/D.

\*NCV prefix is for automotive and other applications requiring site and control changes.

# MECHANICAL CASE OUTLINE PACKAGE DIMENSIONS

ON Semiconductor®



SCALE 1:1

PDIP-8  
CASE 626-05  
ISSUE P

DATE 22 APR 2015

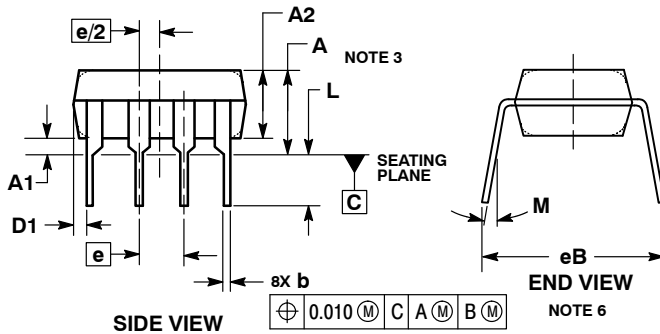
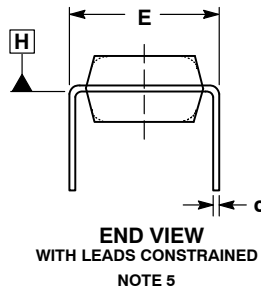
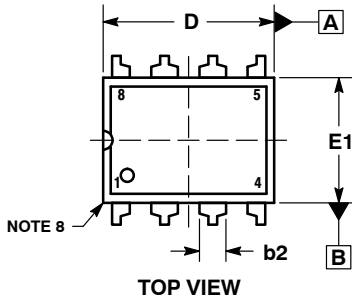

NOTES:

1. DIMENSIONING AND TOLERANCING PER ASME Y14.5M, 1994.
2. CONTROLLING DIMENSION: INCHES.
3. DIMENSIONS A, A1 AND L ARE MEASURED WITH THE PACKAGE SEATED IN JEDEC SEATING PLANE GAUGE GS-3.
4. DIMENSIONS D, D1 AND E1 DO NOT INCLUDE MOLD FLASH OR PROTRUSIONS. MOLD FLASH OR PROTRUSIONS ARE NOT TO EXCEED 0.10 INCH.
5. DIMENSION E IS MEASURED AT A POINT 0.015 BELOW DATUM PLANE H WITH THE LEADS CONSTRAINED PERPENDICULAR TO DATUM C.
6. DIMENSION eB IS MEASURED AT THE LEAD TIPS WITH THE LEADS UNCONSTRAINED.
7. DATUM PLANE H IS COINCIDENT WITH THE BOTTOM OF THE LEADS, WHERE THE LEADS EXIT THE BODY.
8. PACKAGE CONTOUR IS OPTIONAL (ROUNDED OR SQUARE CORNERS).

DIM	INCHES		MILLIMETERS	
	MIN	MAX	MIN	MAX
A	----	0.210	----	5.33
A1	0.015	----	0.38	----
A2	0.115	0.195	2.92	4.95
b	0.014	0.022	0.35	0.56
b2	0.060 TYP		1.52 TYP	
C	0.008	0.014	0.20	0.36
D	0.355	0.400	9.02	10.16
D1	0.005	----	0.13	----
E	0.300	0.325	7.62	8.26
E1	0.240	0.280	6.10	7.11
e	0.100 BSC		2.54 BSC	
eB	----	0.430	----	10.92
L	0.115	0.150	2.92	3.81
M	----	10°	----	10°

GENERIC MARKING DIAGRAM\*

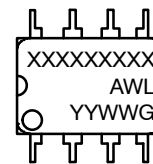

- XXXX = Specific Device Code
- A = Assembly Location
- WL = Wafer Lot
- YY = Year
- WW = Work Week
- G = Pb-Free Package

\*This information is generic. Please refer to device data sheet for actual part marking. Pb-Free indicator, "G" or microdot "▪", may or may not be present.

- STYLE 1:  
PIN 1. AC IN  
2. DC + IN  
3. DC - IN  
4. AC IN  
5. GROUND  
6. OUTPUT  
7. AUXILIARY  
8. V<sub>CC</sub>

DOCUMENT NUMBER:	98ASB42420B	Electronic versions are uncontrolled except when accessed directly from the Document Repository. Printed versions are uncontrolled except when stamped "CONTROLLED COPY" in red.
DESCRIPTION:	PDIP-8	PAGE 1 OF 1

ON Semiconductor and are trademarks of Semiconductor Components Industries, LLC dba ON Semiconductor or its subsidiaries in the United States and/or other countries. ON Semiconductor reserves the right to make changes without further notice to any products herein. ON Semiconductor makes no warranty, representation or guarantee regarding the suitability of its products for any particular purpose, nor does ON Semiconductor assume any liability arising out of the application or use of any product or circuit, and specifically disclaims any and all liability, including without limitation special, consequential or incidental damages. ON Semiconductor does not convey any license under its patent rights nor the rights of others.

# MECHANICAL CASE OUTLINE PACKAGE DIMENSIONS

ON Semiconductor®

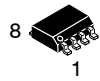

SCALE 1:1

SOIC-8 NB  
CASE 751-07  
ISSUE AK

DATE 16 FEB 2011

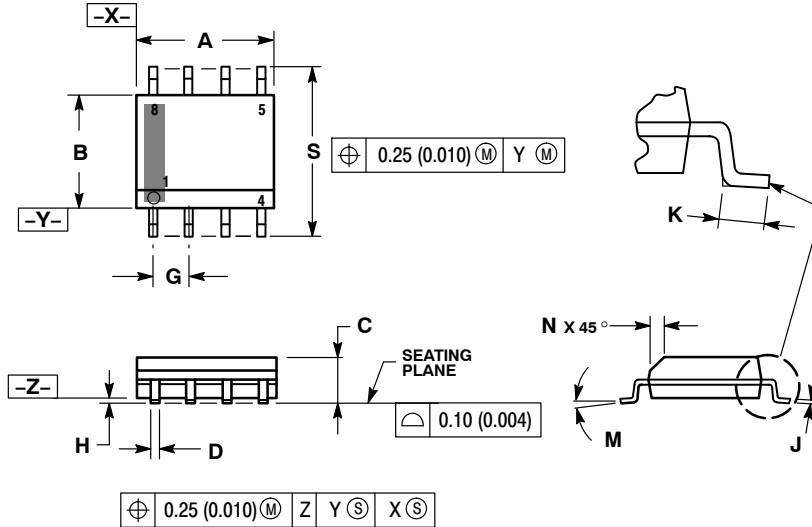

- NOTES:
1. DIMENSIONING AND TOLERANCING PER ANSI Y14.5M, 1982.
  2. CONTROLLING DIMENSION: MILLIMETER.
  3. DIMENSION A AND B DO NOT INCLUDE MOLD PROTRUSION.
  4. MAXIMUM MOLD PROTRUSION 0.15 (0.006) PER SIDE.
  5. DIMENSION D DOES NOT INCLUDE DAMBAR PROTRUSION. ALLOWABLE DAMBAR PROTRUSION SHALL BE 0.127 (0.005) TOTAL IN EXCESS OF THE D DIMENSION AT MAXIMUM MATERIAL CONDITION.
  6. 751-01 THRU 751-06 ARE OBSOLETE. NEW STANDARD IS 751-07.

DIM	MILLIMETERS		INCHES	
	MIN	MAX	MIN	MAX
A	4.80	5.00	0.189	0.197
B	3.80	4.00	0.150	0.157
C	1.35	1.75	0.053	0.069
D	0.33	0.51	0.013	0.020
G	1.27 BSC		0.050 BSC	
H	0.10	0.25	0.004	0.010
J	0.19	0.25	0.007	0.010
K	0.40	1.27	0.016	0.050
M	0°	8°	0°	8°
N	0.25	0.50	0.010	0.020
S	5.80	6.20	0.228	0.244

## GENERIC MARKING DIAGRAM\*

### SOLDERING FOOTPRINT\*

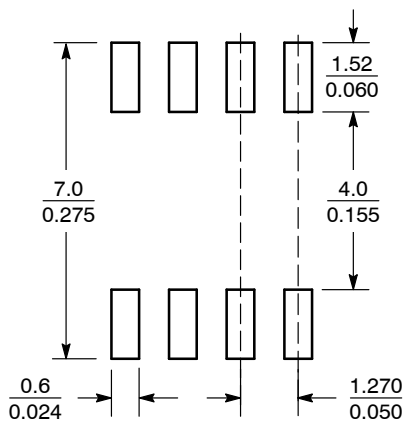

SCALE 6:1 (mm/inches)

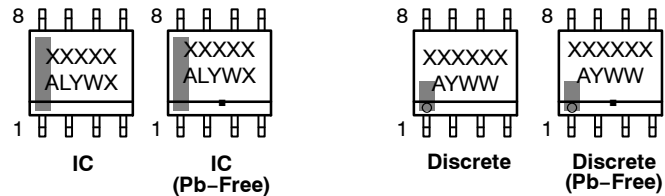

XXXXXX = Specific Device Code  
A = Assembly Location  
L = Wafer Lot  
Y = Year  
W = Work Week  
▪ = Pb-Free Package

XXXXXX = Specific Device Code  
A = Assembly Location  
Y = Year  
WW = Work Week  
▪ = Pb-Free Package

\*This information is generic. Please refer to device data sheet for actual part marking. Pb-Free indicator, "G" or microdot "▪", may or may not be present. Some products may not follow the Generic Marking.

\*For additional information on our Pb-Free strategy and soldering details, please download the ON Semiconductor Soldering and Mounting Techniques Reference Manual, SOLDERRM/D.

STYLES ON PAGE 2

DOCUMENT NUMBER:	98ASB42564B	Electronic versions are uncontrolled except when accessed directly from the Document Repository. Printed versions are uncontrolled except when stamped "CONTROLLED COPY" in red.
DESCRIPTION:	SOIC-8 NB	PAGE 1 OF 2

ON Semiconductor and ON are trademarks of Semiconductor Components Industries, LLC dba ON Semiconductor or its subsidiaries in the United States and/or other countries. ON Semiconductor reserves the right to make changes without further notice to any products herein. ON Semiconductor makes no warranty, representation or guarantee regarding the suitability of its products for any particular purpose, nor does ON Semiconductor assume any liability arising out of the application or use of any product or circuit, and specifically disclaims any and all liability, including without limitation special, consequential or incidental damages. ON Semiconductor does not convey any license under its patent rights nor the rights of others.

**SOIC-8 NB**  
**CASE 751-07**  
**ISSUE AK**

DATE 16 FEB 2011

- |  |   |   |   |
|--|---|---|---|
| <p><b>STYLE 1:</b><br/>         PIN 1. EMITTER<br/>         2. COLLECTOR<br/>         3. COLLECTOR<br/>         4. EMITTER<br/>         5. EMITTER<br/>         6. BASE<br/>         7. BASE<br/>         8. EMITTER</p>   | <p><b>STYLE 2:</b><br/>         PIN 1. COLLECTOR, DIE, #1<br/>         2. COLLECTOR, #1<br/>         3. COLLECTOR, #2<br/>         4. COLLECTOR, #2<br/>         5. BASE, #2<br/>         6. EMITTER, #2<br/>         7. BASE, #1<br/>         8. EMITTER, #1</p>               | <p><b>STYLE 3:</b><br/>         PIN 1. DRAIN, DIE #1<br/>         2. DRAIN, #1<br/>         3. DRAIN, #2<br/>         4. DRAIN, #2<br/>         5. GATE, #2<br/>         6. SOURCE, #2<br/>         7. GATE, #1<br/>         8. SOURCE, #1</p>                            | <p><b>STYLE 4:</b><br/>         PIN 1. ANODE<br/>         2. ANODE<br/>         3. ANODE<br/>         4. ANODE<br/>         5. ANODE<br/>         6. ANODE<br/>         7. ANODE<br/>         8. COMMON CATHODE</p>   |
| <p><b>STYLE 5:</b><br/>         PIN 1. DRAIN<br/>         2. DRAIN<br/>         3. DRAIN<br/>         4. DRAIN<br/>         5. GATE<br/>         6. GATE<br/>         7. SOURCE<br/>         8. SOURCE</p>   | <p><b>STYLE 6:</b><br/>         PIN 1. SOURCE<br/>         2. DRAIN<br/>         3. DRAIN<br/>         4. SOURCE<br/>         5. SOURCE<br/>         6. GATE<br/>         7. GATE<br/>         8. SOURCE</p>  | <p><b>STYLE 7:</b><br/>         PIN 1. INPUT<br/>         2. EXTERNAL BYPASS<br/>         3. THIRD STAGE SOURCE<br/>         4. GROUND<br/>         5. DRAIN<br/>         6. GATE 3<br/>         7. SECOND STAGE Vd<br/>         8. FIRST STAGE Vd</p>                    | <p><b>STYLE 8:</b><br/>         PIN 1. COLLECTOR, DIE #1<br/>         2. BASE, #1<br/>         3. BASE, #2<br/>         4. COLLECTOR, #2<br/>         5. COLLECTOR, #2<br/>         6. EMITTER, #2<br/>         7. EMITTER, #1<br/>         8. COLLECTOR, #1</p>                              |
| <p><b>STYLE 9:</b><br/>         PIN 1. EMITTER, COMMON<br/>         2. COLLECTOR, DIE #1<br/>         3. COLLECTOR, DIE #2<br/>         4. EMITTER, COMMON<br/>         5. EMITTER, COMMON<br/>         6. BASE, DIE #2<br/>         7. BASE, DIE #1<br/>         8. EMITTER, COMMON</p> | <p><b>STYLE 10:</b><br/>         PIN 1. GROUND<br/>         2. BIAS 1<br/>         3. OUTPUT<br/>         4. GROUND<br/>         5. GROUND<br/>         6. BIAS 2<br/>         7. INPUT<br/>         8. GROUND</p>  | <p><b>STYLE 11:</b><br/>         PIN 1. SOURCE 1<br/>         2. GATE 1<br/>         3. SOURCE 2<br/>         4. GATE 2<br/>         5. DRAIN 2<br/>         6. DRAIN 2<br/>         7. DRAIN 1<br/>         8. DRAIN 1</p>   | <p><b>STYLE 12:</b><br/>         PIN 1. SOURCE<br/>         2. SOURCE<br/>         3. SOURCE<br/>         4. GATE<br/>         5. DRAIN<br/>         6. DRAIN<br/>         7. DRAIN<br/>         8. DRAIN</p>   |
| <p><b>STYLE 13:</b><br/>         PIN 1. N.C.<br/>         2. SOURCE<br/>         3. SOURCE<br/>         4. GATE<br/>         5. DRAIN<br/>         6. DRAIN<br/>         7. DRAIN<br/>         8. DRAIN</p>  | <p><b>STYLE 14:</b><br/>         PIN 1. N-SOURCE<br/>         2. N-GATE<br/>         3. P-SOURCE<br/>         4. P-GATE<br/>         5. P-DRAIN<br/>         6. P-DRAIN<br/>         7. N-DRAIN<br/>         8. N-DRAIN</p>   | <p><b>STYLE 15:</b><br/>         PIN 1. ANODE 1<br/>         2. ANODE 1<br/>         3. ANODE 1<br/>         4. ANODE 1<br/>         5. CATHODE, COMMON<br/>         6. CATHODE, COMMON<br/>         7. CATHODE, COMMON<br/>         8. CATHODE, COMMON</p>               | <p><b>STYLE 16:</b><br/>         PIN 1. EMITTER, DIE #1<br/>         2. BASE, DIE #1<br/>         3. EMITTER, DIE #2<br/>         4. BASE, DIE #2<br/>         5. COLLECTOR, DIE #2<br/>         6. COLLECTOR, DIE #2<br/>         7. COLLECTOR, DIE #1<br/>         8. COLLECTOR, DIE #1</p> |
| <p><b>STYLE 17:</b><br/>         PIN 1. VCC<br/>         2. V2OUT<br/>         3. V1OUT<br/>         4. TXE<br/>         5. RXE<br/>         6. VEE<br/>         7. GND<br/>         8. ACC</p>  | <p><b>STYLE 18:</b><br/>         PIN 1. ANODE<br/>         2. ANODE<br/>         3. SOURCE<br/>         4. GATE<br/>         5. DRAIN<br/>         6. DRAIN<br/>         7. CATHODE<br/>         8. CATHODE</p>   | <p><b>STYLE 19:</b><br/>         PIN 1. SOURCE 1<br/>         2. GATE 1<br/>         3. SOURCE 2<br/>         4. GATE 2<br/>         5. DRAIN 2<br/>         6. MIRROR 2<br/>         7. DRAIN 1<br/>         8. MIRROR 1</p>   | <p><b>STYLE 20:</b><br/>         PIN 1. SOURCE (N)<br/>         2. GATE (N)<br/>         3. SOURCE (P)<br/>         4. GATE (P)<br/>         5. DRAIN<br/>         6. DRAIN<br/>         7. DRAIN<br/>         8. DRAIN</p>   |
| <p><b>STYLE 21:</b><br/>         PIN 1. CATHODE 1<br/>         2. CATHODE 2<br/>         3. CATHODE 3<br/>         4. CATHODE 4<br/>         5. CATHODE 5<br/>         6. COMMON ANODE<br/>         7. COMMON ANODE<br/>         8. CATHODE 6</p>  | <p><b>STYLE 22:</b><br/>         PIN 1. I/O LINE 1<br/>         2. COMMON CATHODE/VCC<br/>         3. COMMON CATHODE/VCC<br/>         4. I/O LINE 3<br/>         5. COMMON ANODE/GND<br/>         6. I/O LINE 4<br/>         7. I/O LINE 5<br/>         8. COMMON ANODE/GND</p> | <p><b>STYLE 23:</b><br/>         PIN 1. LINE 1 IN<br/>         2. COMMON ANODE/GND<br/>         3. COMMON ANODE/GND<br/>         4. LINE 2 IN<br/>         5. LINE 2 OUT<br/>         6. COMMON ANODE/GND<br/>         7. COMMON ANODE/GND<br/>         8. LINE 1 OUT</p> | <p><b>STYLE 24:</b><br/>         PIN 1. BASE<br/>         2. EMITTER<br/>         3. COLLECTOR/ANODE<br/>         4. COLLECTOR/ANODE<br/>         5. CATHODE<br/>         6. CATHODE<br/>         7. COLLECTOR/ANODE<br/>         8. COLLECTOR/ANODE</p>                                      |
| <p><b>STYLE 25:</b><br/>         PIN 1. VIN<br/>         2. N/C<br/>         3. REXT<br/>         4. GND<br/>         5. IOUT<br/>         6. IOUT<br/>         7. IOUT<br/>         8. IOUT</p>   | <p><b>STYLE 26:</b><br/>         PIN 1. GND<br/>         2. dv/dt<br/>         3. ENABLE<br/>         4. ILIMIT<br/>         5. SOURCE<br/>         6. SOURCE<br/>         7. SOURCE<br/>         8. VCC</p>  | <p><b>STYLE 27:</b><br/>         PIN 1. ILIMIT<br/>         2. OVLO<br/>         3. UVLO<br/>         4. INPUT+<br/>         5. SOURCE<br/>         6. SOURCE<br/>         7. SOURCE<br/>         8. DRAIN</p>  | <p><b>STYLE 28:</b><br/>         PIN 1. SW_TO_GND<br/>         2. DASIC_OFF<br/>         3. DASIC_SW_DET<br/>         4. GND<br/>         5. V_MON<br/>         6. VBULK<br/>         7. VBULK<br/>         8. VIN</p>  |
| <p><b>STYLE 29:</b><br/>         PIN 1. BASE, DIE #1<br/>         2. EMITTER, #1<br/>         3. BASE, #2<br/>         4. EMITTER, #2<br/>         5. COLLECTOR, #2<br/>         6. COLLECTOR, #2<br/>         7. COLLECTOR, #1<br/>         8. COLLECTOR, #1</p>                        | <p><b>STYLE 30:</b><br/>         PIN 1. DRAIN 1<br/>         2. DRAIN 1<br/>         3. GATE 2<br/>         4. SOURCE 2<br/>         5. SOURCE 1/DRAIN 2<br/>         6. SOURCE 1/DRAIN 2<br/>         7. SOURCE 1/DRAIN 2<br/>         8. GATE 1</p>                           |   |   |

<b>DOCUMENT NUMBER:</b>	<b>98ASB42564B</b>	Electronic versions are uncontrolled except when accessed directly from the Document Repository. Printed versions are uncontrolled except when stamped "CONTROLLED COPY" in red.
<b>DESCRIPTION:</b>	<b>SOIC-8 NB</b>	<b>PAGE 2 OF 2</b>

ON Semiconductor and  are trademarks of Semiconductor Components Industries, LLC dba ON Semiconductor or its subsidiaries in the United States and/or other countries. ON Semiconductor reserves the right to make changes without further notice to any products herein. ON Semiconductor makes no warranty, representation or guarantee regarding the suitability of its products for any particular purpose, nor does ON Semiconductor assume any liability arising out of the application or use of any product or circuit, and specifically disclaims any and all liability, including without limitation special, consequential or incidental damages. ON Semiconductor does not convey any license under its patent rights nor the rights of others.

**onsemi**, **Onsemi**, and other names, marks, and brands are registered and/or common law trademarks of Semiconductor Components Industries, LLC dba "**onsemi**" or its affiliates and/or subsidiaries in the United States and/or other countries. **onsemi** owns the rights to a number of patents, trademarks, copyrights, trade secrets, and other intellectual property. A listing of **onsemi**'s product/patent coverage may be accessed at [www.onsemi.com/site/pdf/Patent-Marking.pdf](http://www.onsemi.com/site/pdf/Patent-Marking.pdf). **onsemi** reserves the right to make changes at any time to any products or information herein, without notice. The information herein is provided "as-is" and **onsemi** makes no warranty, representation or guarantee regarding the accuracy of the information, product features, availability, functionality, or suitability of its products for any particular purpose, nor does **onsemi** assume any liability arising out of the application or use of any product or circuit, and specifically disclaims any and all liability, including without limitation special, consequential or incidental damages. Buyer is responsible for its products and applications using **onsemi** products, including compliance with all laws, regulations and safety requirements or standards, regardless of any support or applications information provided by **onsemi**. "Typical" parameters which may be provided in **onsemi** data sheets and/or specifications can and do vary in different applications and actual performance may vary over time. All operating parameters, including "Typicals" must be validated for each customer application by customer's technical experts. **onsemi** does not convey any license under any of its intellectual property rights nor the rights of others. **onsemi** products are not designed, intended, or authorized for use as a critical component in life support systems or any FDA Class 3 medical devices or medical devices with a same or similar classification in a foreign jurisdiction or any devices intended for implantation in the human body. Should Buyer purchase or use **onsemi** products for any such unintended or unauthorized application, Buyer shall indemnify and hold **onsemi** and its officers, employees, subsidiaries, affiliates, and distributors harmless against all claims, costs, damages, and expenses, and reasonable attorney fees arising out of, directly or indirectly, any claim of personal injury or death associated with such unintended or unauthorized use, even if such claim alleges that **onsemi** was negligent regarding the design or manufacture of the part. **onsemi** is an Equal Opportunity/Affirmative Action Employer. This literature is subject to all applicable copyright laws and is not for resale in any manner.

## PUBLICATION ORDERING INFORMATION

### LITERATURE FULFILLMENT:

Email Requests to: [orderlit@onsemi.com](mailto:orderlit@onsemi.com)

**onsemi** Website: [www.onsemi.com](http://www.onsemi.com)

### TECHNICAL SUPPORT

**North American Technical Support:**

Voice Mail: 1 800-282-9855 Toll Free USA/Canada

Phone: 011 421 33 790 2910

**Europe, Middle East and Africa Technical Support:**

Phone: 00421 33 790 2910

For additional information, please contact your local Sales Representative

