

MMT05B230T3, MMT05B260T3, MMT05B310T3

Preferred Devices

Thyristor Surge Protectors High Voltage Bidirectional TSPD

These Thyristor Surge Protective devices (TSPD) prevent overvoltage damage to sensitive circuits by lightning, induction and power line crossings. They are breakover-triggered crowbar protectors. Turn-off occurs when the surge current falls below the holding current value.

Secondary protection applications for electronic telecom equipment at customer premises.

Features

- High Surge Current Capability: 50 A 10 x 1000 μ sec, for Controlled Temperature Environments
- The MMT05B230T3 Series is used to help equipment meet various regulatory requirements including: Bellcore 1089, ITU K.20 & K.21, IEC 950, UL 1459 & 1950 and FCC Part 68
- Bidirectional Protection in a Single Device
- Little Change of Voltage Limit with Transient Amplitude or Rate
- Freedom from Wearout Mechanisms Present in Non-Semiconductor Devices
- Fail-Safe, Shorts When Overstressed, Preventing Continued Unprotected Operation
- Surface Mount Technology (SMT)
-  Indicates UL Registered – File #E210057
- Pb-Free Packages are Available

MAXIMUM RATINGS ($T_J = 25^\circ\text{C}$ unless otherwise noted)

Rating	Symbol	Value	Unit
Off-State Voltage – Maximum MMT05B230T3 MMT05B260T3 MMT05B310T3	V_{DM}	± 170 ± 200 ± 270	V
Maximum Pulse Surge Short Circuit Current Non-Repetitive Double Exponential Decay Waveform (Notes 1 and 2) (-25°C Initial Temperature) 8 x 20 μ sec 10 x 160 μ sec 10 x 560 μ sec 10 x 1000 μ sec	I_{PPS1} I_{PPS2} I_{PPS3} I_{PPS4}	± 150 ± 100 ± 70 ± 50	A(pk)
Maximum Non-Repetitive Rate of Change of On-State Current Double Exponential Waveform, $R = 1.0$, $L = 1.5 \mu\text{H}$, $C = 1.67 \mu\text{F}$, $I_{pk} = 110\text{A}$	di/dt	± 150	A/ μ s

Stresses exceeding Maximum Ratings may damage the device. Maximum Ratings are stress ratings only. Functional operation above the Recommended Operating Conditions is not implied. Extended exposure to stresses above the Recommended Operating Conditions may affect device reliability.

1. Allow cooling before testing second polarity.
2. Measured under pulse conditions to reduce heating.



ON Semiconductor®

<http://onsemi.com>

BIDIRECTIONAL TSPD (⚡)
50 AMPERE SURGE
265 thru 365 VOLTS



SMB
(No Polarity)
(Essentially JEDEC DO-214AA)
CASE 403C

MARKING DIAGRAMS

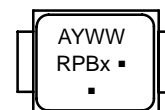

RPBx = Device Code
x = G or J
Y = Year
WW = Work Week
▪ = Pb-Free Package

ORDERING INFORMATION

See detailed ordering and shipping information in the package dimensions section on page 5 of this data sheet.

Preferred devices are recommended choices for future use and best overall value.

MMT05B230T3, MMT05B260T3, MMT05B310T3

THERMAL CHARACTERISTICS

Characteristic	Symbol	Max	Unit
Operating Temperature Range Blocking or Conducting State	T_{J1}	-40 to +125	°C
Overload Junction Temperature – Maximum Conducting State Only	T_{J2}	+175	°C
Instantaneous Peak Power Dissipation ($I_{pk} = 50$ A, 10×1000 μ sec @ 25°C)	P_{PK}	2000	W
Maximum Lead Temperature for Soldering Purposes 1/8" from Case for 10 Seconds	T_L	260	°C

ELECTRICAL CHARACTERISTICS ($T_J = 25^\circ\text{C}$ unless otherwise noted) Devices are bidirectional. All electrical parameters apply to forward and reverse polarities.

Characteristics	Symbol	Min	Typ	Max	Unit
Breakover Voltage (Both polarities) ($dv/dt = 100$ V/ μ s, $I_{SC} = 1.0$ A, $V_{dc} = 1000$ V) (+65°C)	$V_{(BO)}$	-	-	265 320 365 280 340 400	V
Breakover Voltage (Both polarities) ($f = 60$ Hz, $I_{SC} = 1.0$ A(rms), $V_{OC} = 1000$ V(rms), $R_f = 1.0$ k Ω , $t = 0.5$ cycle) (Note 3) (+65°C)	$V_{(BO)}$	-	-	265 320 365 280 340 400	V
Breakover Voltage Temperature Coefficient	$dV_{(BO)}/dT_J$	-	0.08	-	%/°C
Breakdown Voltage ($I_{(BR)} = 1.0$ mA) Both polarities	$V_{(BR)}$	-	190 240 280	-	V
Off State Current ($V_{D1} = 50$ V) Both polarities ($V_{D2} = V_{DM}$) Both polarities	I_{D1} I_{D2}	-	-	2.0 5.0	μ A
On-State Voltage ($I_T = 1.0$ A) ($PW \leq 300$ μ s, Duty Cycle $\leq 2\%$) (Note 3)	V_T	-	1.53	3.0	V
Breakover Current ($f = 60$ Hz, $V_{DM} = 1000$ V(rms), $R_S = 1.0$ k Ω) – Both polarities	I_{BO}	-	230	-	mA
Holding Current (Both polarities) (Note 3) $V_S = 500$ V; I_T (Initiating Current) = ± 1.0 A	I_H	150	340	-	mA
Critical Rate of Rise of Off-State Voltage (Linear waveform, $V_D = \text{Rated } V_{BR}$, $T_J = 25^\circ\text{C}$)	dv/dt	2000	-	-	V/ μ s
Capacitance ($f = 1.0$ MHz, 50 Vdc, 1.0 V rms Signal) ($f = 1.0$ MHz, 2.0 Vdc, 15 mV rms Signal)	C_O	-	22 53	- 75	pF

3. Measured under pulse conditions to reduce heating.

MMT05B230T3, MMT05B260T3, MMT05B310T3

Voltage Current Characteristic of TSPD (Bidirectional Device)

Symbol	Parameter
I_{D1}, I_{D2}	Off State Leakage Current
V_{D1}, V_{D2}	Off State Blocking Voltage
V_{BR}	Breakdown Voltage
V_{BO}	Breakover Voltage
I_{BO}	Breakover Current
I_H	Holding Current
V_{TM}	On State Voltage

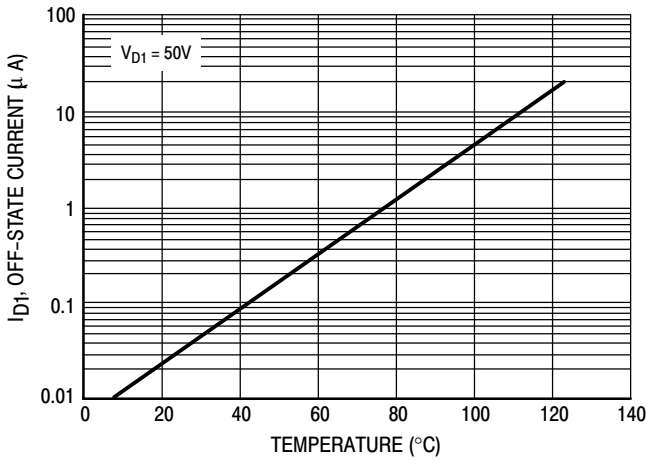
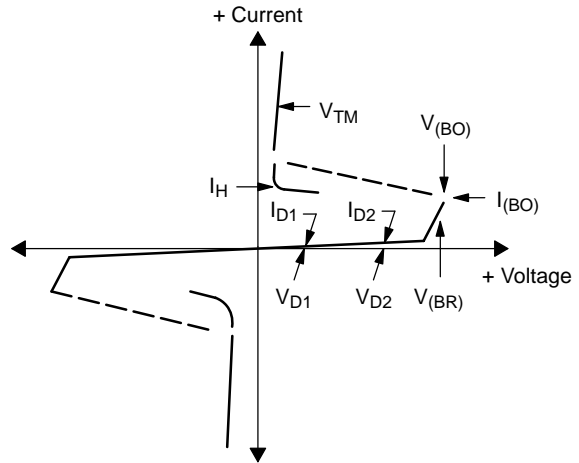

Figure 1. Off-State Current versus Temperature

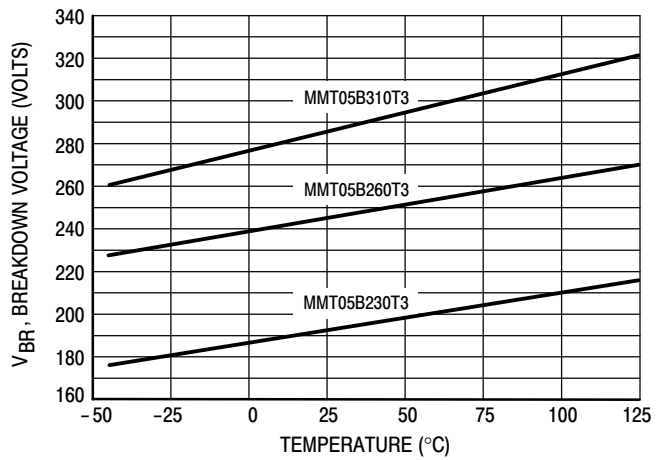

Figure 2. Breakdown Voltage versus Temperature

MMT05B230T3, MMT05B260T3, MMT05B310T3

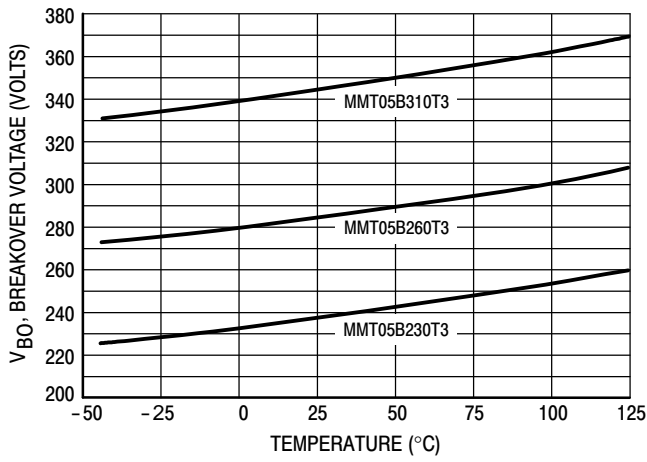

Figure 3. Breakover Voltage versus Temperature

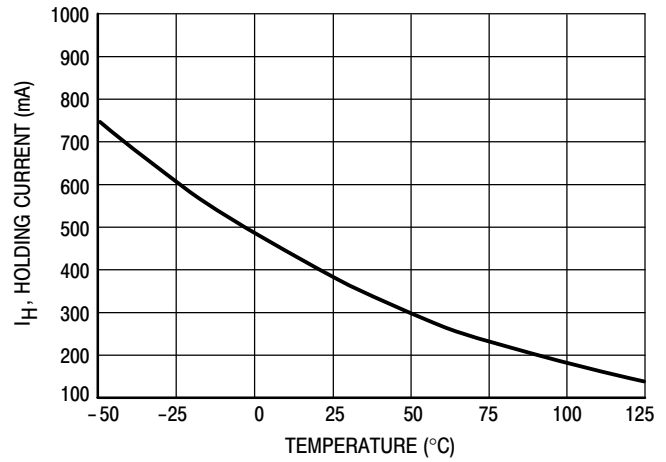

Figure 4. Holding Current versus Temperature

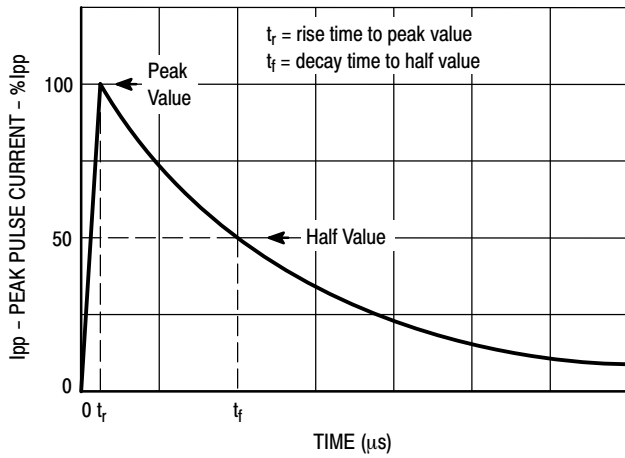

Figure 5. Exponential Decay Pulse Waveform

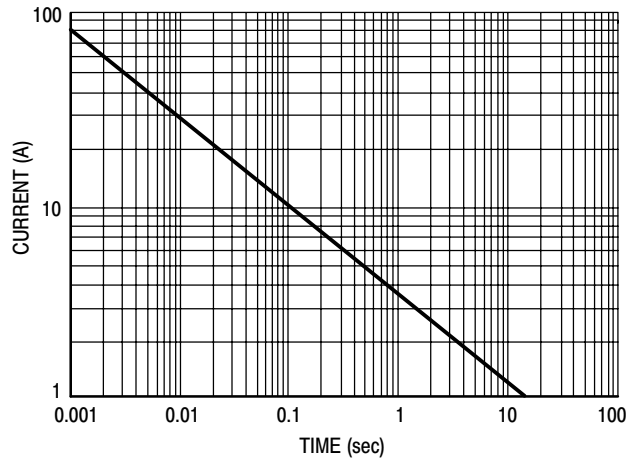
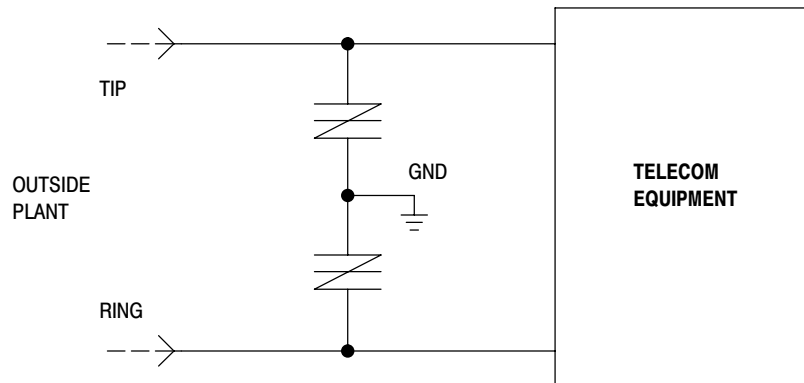
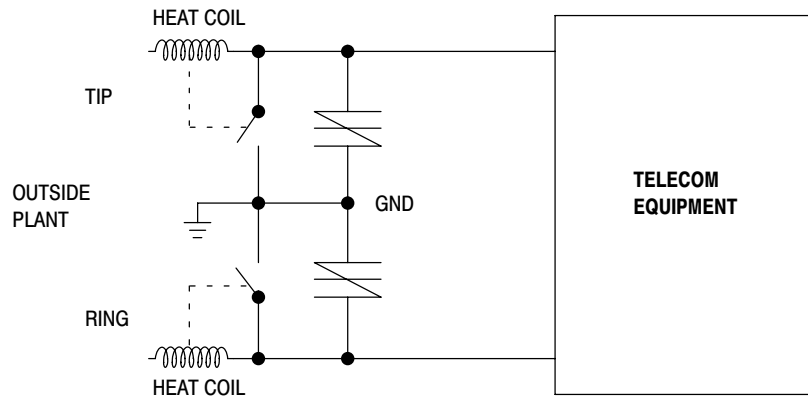
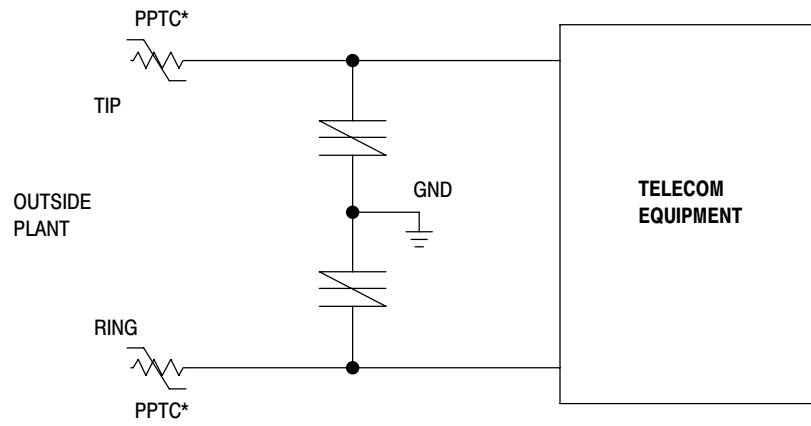

Figure 6. Peak Surge On-State Current versus Surge Current Duration, Sinusoidal Waveform



MMT05B230T3, MMT05B260T3, MMT05B310T3



ORDERING INFORMATION

Device	Package	Shipping [†]
MMT05B230T3	SMB	2500 / Tape & Reel
MMT05B230T3G	SMB (Pb-Free)	
MMT05B260T3	SMB	
MMT05B260T3G	SMB (Pb-Free)	
MMT05B310T3	SMB	
MMT05B310T3G	SMB (Pb-Free)	

[†]For information on tape and reel specifications, including part orientation and tape sizes, please refer to our Tape and Reel Packaging Specifications Brochure, BRD8011/D.

MECHANICAL CASE OUTLINE

PACKAGE DIMENSIONS

ON Semiconductor®



SMB CASE 403C-01 ISSUE A

DATE 01/02/2000



SCALE 1:1

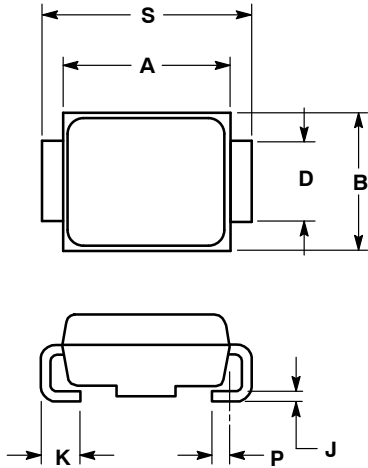

NOTES:

1. DIMENSIONING AND TOLERANCING PER ANSI Y14.5M, 1982.
2. CONTROLLING DIMENSION: INCH.
3. D DIMENSION SHALL BE MEASURED WITHIN DIMENSION P.

DIM	INCHES		MILLIMETERS	
	MIN	MAX	MIN	MAX
A	0.160	0.180	4.06	4.57
B	0.130	0.150	3.30	3.81
C	0.075	0.095	1.90	2.41
D	0.077	0.083	1.96	2.11
H	0.0020	0.0060	0.051	0.152
J	0.006	0.012	0.15	0.30
K	0.030	0.050	0.76	1.27
P	0.020	REF	0.51	REF
S	0.205	0.220	5.21	5.59

MARKING DIAGRAM

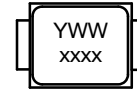

- xxxx = Specific Device Code
- Y = Year
- WW = Work Week

DOCUMENT NUMBER:	98ARB18918C	Electronic versions are uncontrolled except when accessed directly from the Document Repository. Printed versions are uncontrolled except when stamped "CONTROLLED COPY" in red.
DESCRIPTION:	SMB	PAGE 1 OF 1

ON Semiconductor and are trademarks of Semiconductor Components Industries, LLC dba ON Semiconductor or its subsidiaries in the United States and/or other countries. ON Semiconductor reserves the right to make changes without further notice to any products herein. ON Semiconductor makes no warranty, representation or guarantee regarding the suitability of its products for any particular purpose, nor does ON Semiconductor assume any liability arising out of the application or use of any product or circuit, and specifically disclaims any and all liability, including without limitation special, consequential or incidental damages. ON Semiconductor does not convey any license under its patent rights nor the rights of others.

ON Semiconductor and  are trademarks of Semiconductor Components Industries, LLC dba ON Semiconductor or its subsidiaries in the United States and/or other countries. ON Semiconductor owns the rights to a number of patents, trademarks, copyrights, trade secrets, and other intellectual property. A listing of ON Semiconductor's product/patent coverage may be accessed at www.onsemi.com/site/pdf/Patent-Marking.pdf. ON Semiconductor reserves the right to make changes without further notice to any products herein. ON Semiconductor makes no warranty, representation or guarantee regarding the suitability of its products for any particular purpose, nor does ON Semiconductor assume any liability arising out of the application or use of any product or circuit, and specifically disclaims any and all liability, including without limitation special, consequential or incidental damages. Buyer is responsible for its products and applications using ON Semiconductor products, including compliance with all laws, regulations and safety requirements or standards, regardless of any support or applications information provided by ON Semiconductor. "Typical" parameters which may be provided in ON Semiconductor data sheets and/or specifications can and do vary in different applications and actual performance may vary over time. All operating parameters, including "Typicals" must be validated for each customer application by customer's technical experts. ON Semiconductor does not convey any license under its patent rights nor the rights of others. ON Semiconductor products are not designed, intended, or authorized for use as a critical component in life support systems or any FDA Class 3 medical devices or medical devices with a same or similar classification in a foreign jurisdiction or any devices intended for implantation in the human body. Should Buyer purchase or use ON Semiconductor products for any such unintended or unauthorized application, Buyer shall indemnify and hold ON Semiconductor and its officers, employees, subsidiaries, affiliates, and distributors harmless against all claims, costs, damages, and expenses, and reasonable attorney fees arising out of, directly or indirectly, any claim of personal injury or death associated with such unintended or unauthorized use, even if such claim alleges that ON Semiconductor was negligent regarding the design or manufacture of the part. ON Semiconductor is an Equal Opportunity/Affirmative Action Employer. This literature is subject to all applicable copyright laws and is not for resale in any manner.

PUBLICATION ORDERING INFORMATION

LITERATURE FULFILLMENT:

Email Requests to: orderlit@onsemi.com

ON Semiconductor Website: www.onsemi.com

TECHNICAL SUPPORT

North American Technical Support:
Voice Mail: 1 800-282-9855 Toll Free USA/Canada
Phone: 011 421 33 790 2910

Europe, Middle East and Africa Technical Support:

Phone: 00421 33 790 2910

For additional information, please contact your local Sales Representative

