

ON Semiconductor

Is Now

onsemi™

To learn more about onsemi™, please visit our website at
www.onsemi.com

onsemi and onsemi and other names, marks, and brands are registered and/or common law trademarks of Semiconductor Components Industries, LLC dba "onsemi" or its affiliates and/or subsidiaries in the United States and/or other countries. onsemi owns the rights to a number of patents, trademarks, copyrights, trade secrets, and other intellectual property. A listing of onsemi product/patent coverage may be accessed at www.onsemi.com/site/pdf/Patent-Marking.pdf. onsemi reserves the right to make changes at any time to any products or information herein, without notice. The information herein is provided "as-is" and onsemi makes no warranty, representation or guarantee regarding the accuracy of the information, product features, availability, functionality, or suitability of its products for any particular purpose, nor does onsemi assume any liability arising out of the application or use of any product or circuit, and specifically disclaims any and all liability, including without limitation special, consequential or incidental damages. Buyer is responsible for its products and applications using onsemi products, including compliance with all laws, regulations and safety requirements or standards, regardless of any support or applications information provided by onsemi. "Typical" parameters which may be provided in onsemi data sheets and/or specifications can and do vary in different applications and actual performance may vary over time. All operating parameters, including "Typicals" must be validated for each customer application by customer's technical experts. onsemi does not convey any license under any of its intellectual property rights nor the rights of others. onsemi products are not designed, intended, or authorized for use as a critical component in life support systems or any FDA Class 3 medical devices or medical devices with a same or similar classification in a foreign jurisdiction or any devices intended for implantation in the human body. Should Buyer purchase or use onsemi products for any such unintended or unauthorized application, Buyer shall indemnify and hold onsemi and its officers, employees, subsidiaries, affiliates, and distributors harmless against all claims, costs, damages, and expenses, and reasonable attorney fees arising out of, directly or indirectly, any claim of personal injury or death associated with such unintended or unauthorized use, even if such claim alleges that onsemi was negligent regarding the design or manufacture of the part. onsemi is an Equal Opportunity/Affirmative Action Employer. This literature is subject to all applicable copyright laws and is not for resale in any manner. Other names and brands may be claimed as the property of others.

ARX3A0 - CSP35

ARX3A0 - CSP35 Evaluation Board User's Manual



ON Semiconductor®

www.onsemi.com

Evaluation Board Overview

The evaluation boards are designed to demonstrate the features of ON Semiconductor's image sensors products. This headboard is intended to plug directly into the Demo3 system. Test points and jumpers on the board provide access to the clock, I/Os and other miscellaneous signals.

Features

- Clock Input
 - ◆ Default – 27 MHz Crystal Oscillator
 - ◆ Optional Demo3 Controlled MClk
- Two Wire Serial Interface
 - ◆ Selectable Base Address
- 2 Lane MIPI Interface
- RoHS Compliant

Block Diagram

EVAL BOARD USER'S MANUAL



Figure 1. ARX3A0 Evaluation Board

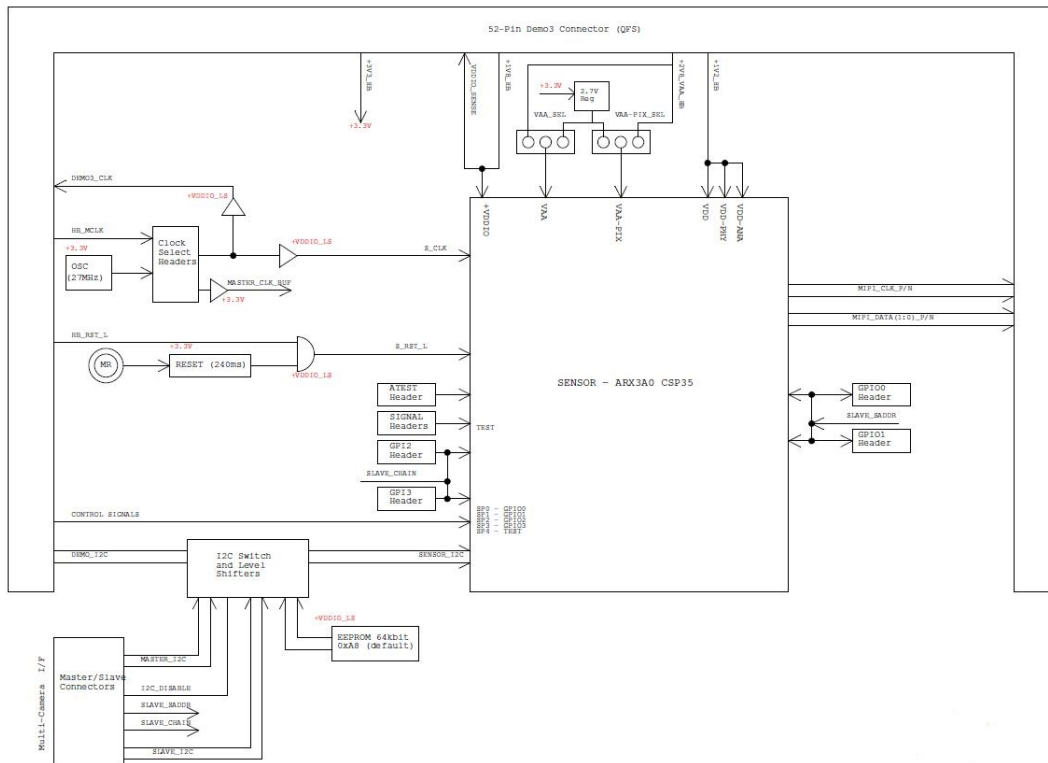

Figure 2. Block Diagram of ARX3A0 Evaluation Board

ARX3A0 – CSP35

Top View

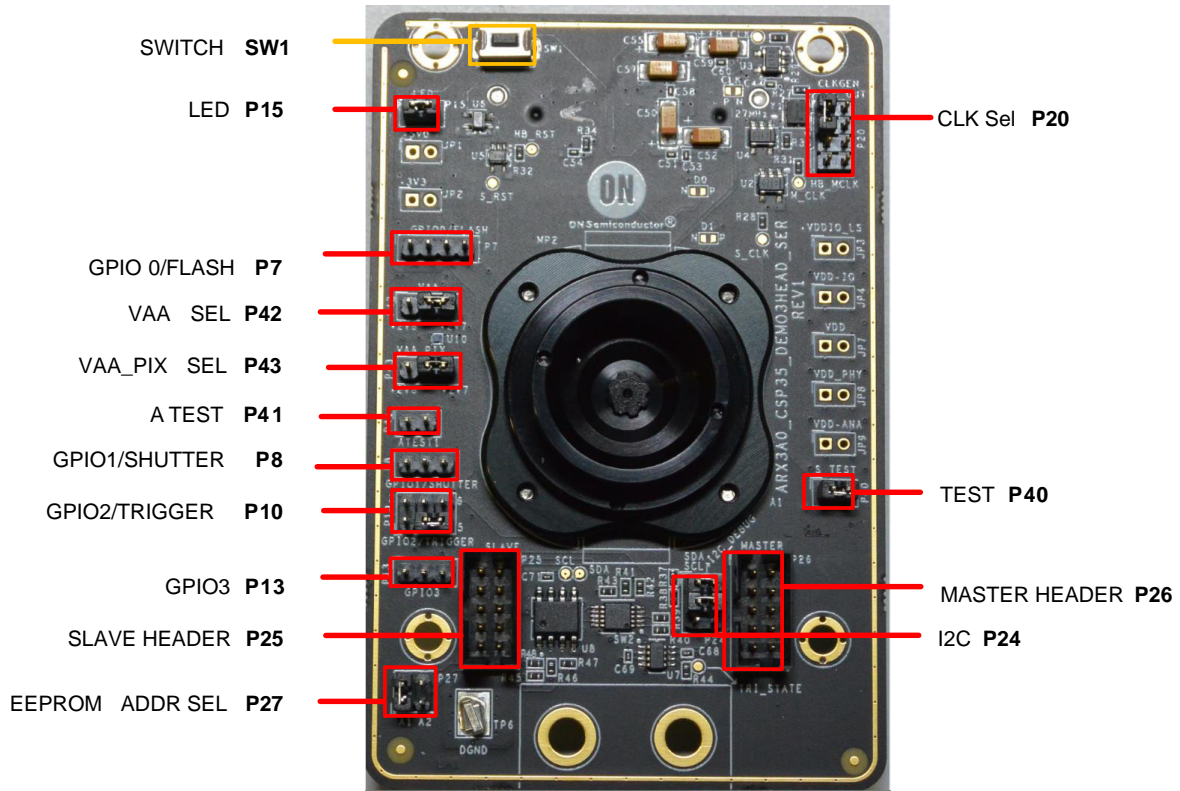

Figure 3. Top View of Evaluation Board – Default Jumpers

Bottom View

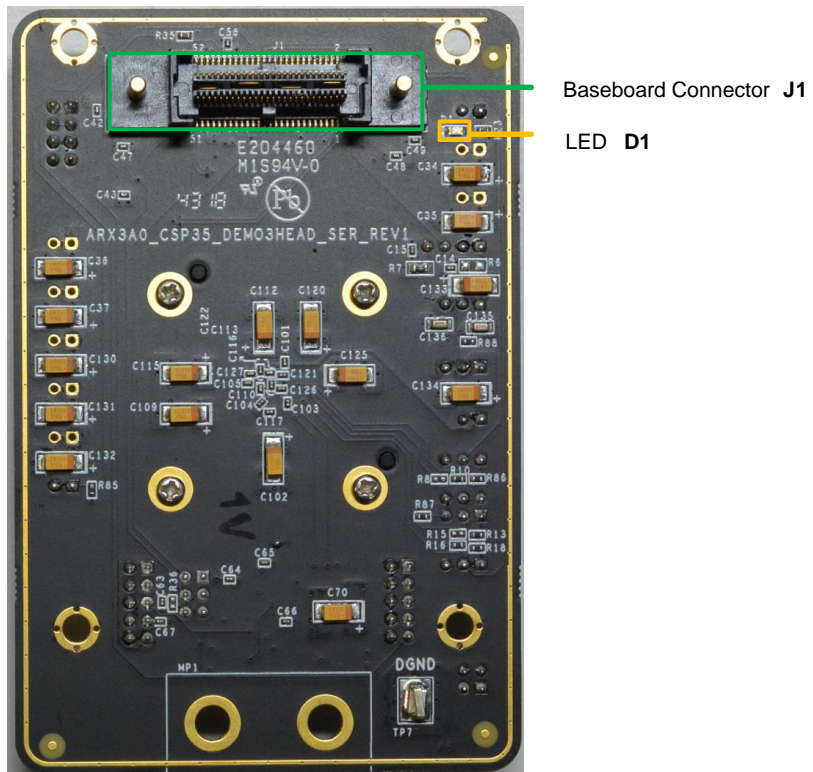

Figure 4. Bottom View of the Evaluation Board – Connector

ARX3A0 – CSP35

Jumper Locations

The jumpers on headboards start with Pin 1 on the leftmost side of the pin. Grouped jumpers increase in pin size with each jumper added.



Figure 5. Pin Locations for a Single Jumper.
Pin 1 is Located at the Leftmost Side and Increases as it Moves to the Right

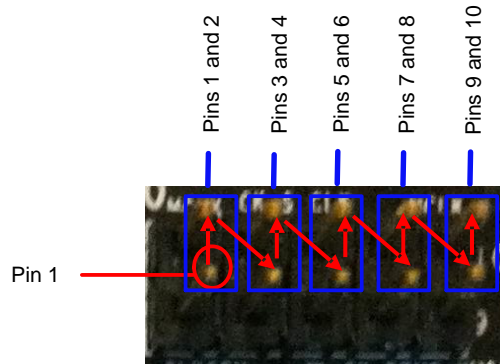

Figure 6. Pin Locations and Assignments of Grouped Jumpers.
Pin 1 is Located at the Bottom–Left Corner and Increases in a Zigzag Fashion Shown in the Picture (P10 and P27)

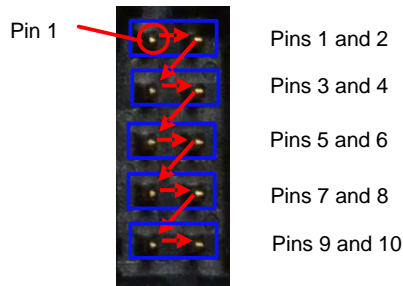

Figure 7. Pin Locations and Assignments of Grouped Jumpers.
Pin 1 is Located at the Top–Left Corner and Increases in a Zigzag Fashion Shown in the Picture (P20, P24, P25 and P26)

ARX3A0 – CSP35

Jumper/Header Functions & Default Positions

Table 1. JUMPERS AND HEADERS

Jumper/Header No.	Jumper/Header Name	Pins	Description
P7	GPIO0/FLASH	Open (Default)	
		1	+5V0
		2	GND
		3	GPIO0/FLASH
		4	+3V3
P8	SHUTTER / GPIO1	Open (Default)	Normal Operation
		1–2	Pulled Up
		2–3	Pulled low
P10	GPIO2/TRIGGER	3–5 (Default)	GPIO2 Pull Down
		1–3	GPIO2 Pull Up
		2–4	Trigger from Demo3
		Pin 4	Function Generator Input
P13	GPIO3	Open (default)	Normal Operation / Multi-Camera Slave Mode
		1–2	GPIO3 Pulled up
		2–3	GPIO3 Pulled down / Master Mode
P15	LED	1–2 (Default)	Power LED ON
		Open	Power LED OFF
P20	CLK Selection	1–3 (Default)	Select on-board oscillator clock & enable master clock output
		2–4	Select Slave clock (for slave sensor in multi-camera mode)
		3–5	Select Demo3 clock
		6–8	Enable Master clock (to support slave sensor in multi-camera mode)
P24	I ² C	1–2 & 3–4 (Default)	Demo3 SCL & SDA connected to sensor SCL & SDA respectively
P25, P26	Multi Camera (Slave/Master)		Refer schematics for the connection
P27	EEPROM Addr. Sel	1–2 Closed & 3–4 Open (Default)	EEPROM Address set to 0xA8
		1–2 open & 3–4 Open	EEPROM Address set to 0xAC
		1–2 open & 3–4 closed	EEPROM Address set to 0xA4
		1–2 Closed & 3–4 closed	EEPROM Address set to 0xA0
P40	TEST	1–2 (Default)	Normal Mode Operation
		Open	Test Mode
P41	ATEST1	Open (Default)	Normal operation
		Pin 1 & 2	Analog manufacturing test access
P42	VAA Sel	2–3 (Default)	VAA is at 2.7 V from the on board LDO
		1–2	VAA is at 2.8 V from Demo3 Baseboard
P43	VAA-PIX Sel	2–3 (Default)	VAA-PIX is at 2.7 V from the on board LDO
		1–2	VAA-PIX is at 2.8 V from Demo3 Baseboard
SW1	RESET	N/A	When pushed, 240 ms reset signal will be sent to ARX3A0

ARX3A0 – CSP35

Interfacing to ON Semiconductor Demo3 Baseboard

The ON Semiconductor Demo3 baseboard has a similar 52-pin connector P5 which mates with J1 of the headboard. The four mounting holes secure the baseboard and the headboard with spacers and screws.

Shorted Jumpers for Power Measurement

Different supplies to the evaluation board are provided by trace shorted jumper, for any voltage and power measurements. To conduct current measurement on a given power rail, cut the trace between the two pins of their respective JP, and insert an ammeter prior to powering up the system. The figure below shows where the trace to cut is located.

Table 2. SHORTED JUMPERS FOR POWER MEASUREMENT

Jumper	Voltage (V)
JP1 (From Demo3)	5.0
JP2 (Peripheral 3.3V)	3.3
JP3 (VDDIO_LS)	1.8
JP4 (VDDIO)	1.8
JP7 (VDD)	1.2
JP8 (VDD-PHY)	1.2
JP9 (VDD-ANA)	1.2
P42 (VAA)	2.7
P43 (VAA-PIX)	2.7

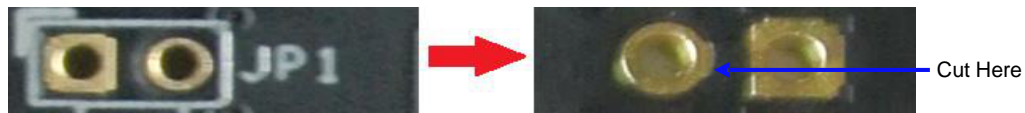

**Figure 8. Top and Bottom View of Shorted Jumper.
The Bottom View Shows the Trace Location to Cut for Current Measurement.**

ON Semiconductor and the ON Semiconductor logo are trademarks of Semiconductor Components Industries, LLC dba ON Semiconductor or its subsidiaries in the United States and/or other countries. ON Semiconductor owns the rights to a number of patents, trademarks, copyrights, trade secrets, and other intellectual property. A listing of ON Semiconductor's product/patent coverage may be accessed at www.onsemi.com/site/pdf/Patent-Marking.pdf. ON Semiconductor is an Equal Opportunity/Affirmative Action Employer. This literature is subject to all applicable copyright laws and is not for resale in any manner.

The evaluation board/kit (research and development board/kit) (hereinafter the "board") is not a finished product and is as such not available for sale to consumers. The board is only intended for research, development, demonstration and evaluation purposes and should as such only be used in laboratory/development areas by persons with an engineering/technical training and familiar with the risks associated with handling electrical/mechanical components, systems and subsystems. This person assumes full responsibility/liability for proper and safe handling. Any other use, resale or redistribution for any other purpose is strictly prohibited.

The board is delivered "AS IS" and without warranty of any kind including, but not limited to, that the board is production-worthy, that the functions contained in the board will meet your requirements, or that the operation of the board will be uninterrupted or error free. ON Semiconductor expressly disclaims all warranties, express, implied or otherwise, including without limitation, warranties of fitness for a particular purpose and non-infringement of intellectual property rights.

ON Semiconductor reserves the right to make changes without further notice to any board.

You are responsible for determining whether the board will be suitable for your intended use or application or will achieve your intended results. Prior to using or distributing any systems that have been evaluated, designed or tested using the board, you agree to test and validate your design to confirm the functionality for your application. Any technical, applications or design information or advice, quality characterization, reliability data or other services provided by ON Semiconductor shall not constitute any representation or warranty by ON Semiconductor, and no additional obligations or liabilities shall arise from ON Semiconductor having provided such information or services.

The boards are not designed, intended, or authorized for use in life support systems, or any FDA Class 3 medical devices or medical devices with a similar or equivalent classification in a foreign jurisdiction, or any devices intended for implantation in the human body. Should you purchase or use the board for any such unintended or unauthorized application, you shall indemnify and hold ON Semiconductor and its officers, employees, subsidiaries, affiliates, and distributors harmless against all claims, costs, damages, and expenses, and reasonable attorney fees arising out of, directly or indirectly, any claim of personal injury or death associated with such unintended or unauthorized use, even if such claim alleges that ON Semiconductor was negligent regarding the design or manufacture of the board.

This evaluation board/kit does not fall within the scope of the European Union directives regarding electromagnetic compatibility, restricted substances (RoHS), recycling (WEEE), FCC, CE or UL, and may not meet the technical requirements of these or other related directives.

FCC WARNING – This evaluation board/kit is intended for use for engineering development, demonstration, or evaluation purposes only and is not considered by ON Semiconductor to be a finished end product fit for general consumer use. It may generate, use, or radiate radio frequency energy and has not been tested for compliance with the limits of computing devices pursuant to part 15 of FCC rules, which are designed to provide reasonable protection against radio frequency interference. Operation of this equipment may cause interference with radio communications, in which case the user shall be responsible, at its expense, to take whatever measures may be required to correct this interference.

ON Semiconductor does not convey any license under its patent rights nor the rights of others.

LIMITATIONS OF LIABILITY: ON Semiconductor shall not be liable for any special, consequential, incidental, indirect or punitive damages, including, but not limited to the costs of requalification, delay, loss of profits or goodwill, arising out of or in connection with the board, even if ON Semiconductor is advised of the possibility of such damages. In no event shall ON Semiconductor's aggregate liability from any obligation arising out of or in connection with the board, under any theory of liability, exceed the purchase price paid for the board, if any.

For more information and documentation, please visit www.onsemi.com.

PUBLICATION ORDERING INFORMATION

LITERATURE FULFILLMENT:

Email Requests to: orderlit@onsemi.com

ON Semiconductor Website: www.onsemi.com

TECHNICAL SUPPORT

North American Technical Support:

Voice Mail: 1 800-282-9855 Toll Free USA/Canada

Phone: 011 421 33 790 2910

Europe, Middle East and Africa Technical Support:

Phone: 00421 33 790 2910

For additional information, please contact your local Sales Representative