**SPIRIT1 169 MHz low data rate transceiver daughterboard
with range extender**

Data brief

**Description**

The STEVAL-IKR002V7D product evaluation board is based on the SPIRIT1, a very low-power RF transceiver intended for RF wireless applications in the sub 1 GHz frequency band.

The STEVAL-IKR002V7D also features an on-board external front-end module from Skyworks® (SKY66100-11), which can reach a maximum output power of +27 dBm (500 mW).

Features

- SPIRIT1 low power sub GHz transceiver in a standalone RF module tuned for 169 MHz, with external Skyworks® front-end module (SKY66100-11)
- Modulation schemes: 2-FSK, GFSK, MSK, GMSK, OOK, and ASK
- Programmable air data rate: from 1 to 500 kbps
- Maximum output power: +27 dBm
- Excellent receiver sensitivity (-123 dBm)
- Suitable for wireless M-BUS applications
- Meets the tight narrow-band system requirements
- Low duty cycle RX/TX operation mode
- Automatic acknowledgment, retransmission, and timeout protocol engine
- AES 128-bit encryption co-processor
- SPI interface for microcontroller
- RoHS compliant

1 Schematic diagram

Figure 1. STEVAL-IKR002V7D circuit schematic (1 of 2)

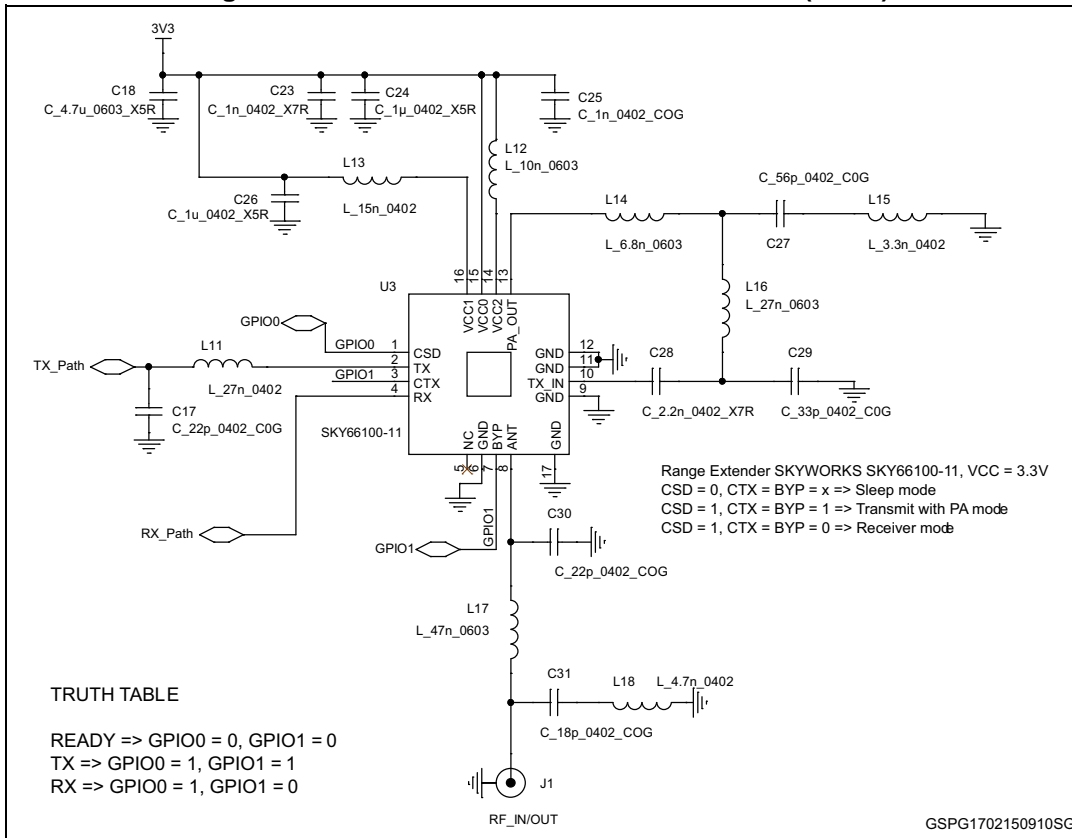
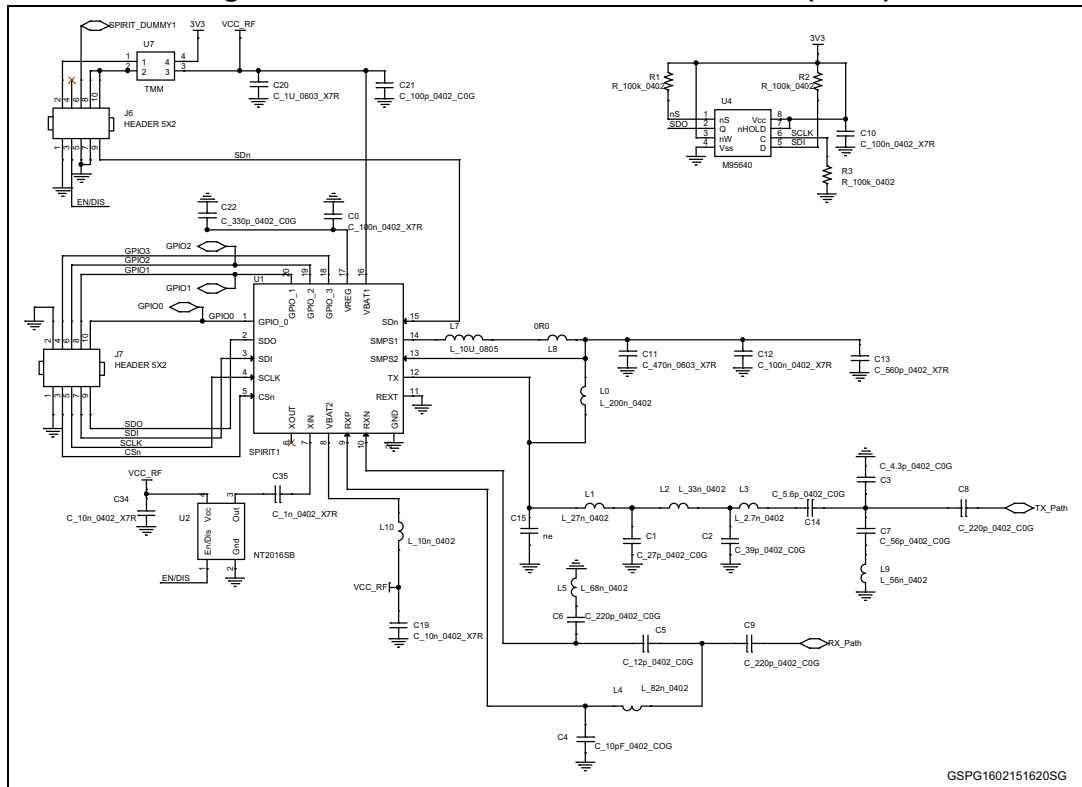

Figure 2. STEVAL-IKR002V7D circuit schematic (2 of 2)



GSPG1602151620SG

2 Revision history

Table 1. Document revision history

Date	Revision	Changes
07-Aug-2014	1	Initial release
19-Feb-2015	2	Updated <i>Figure 1 on page 2</i> and <i>Figure 2 on page 3</i>

IMPORTANT NOTICE – PLEASE READ CAREFULLY

STMicroelectronics NV and its subsidiaries ("ST") reserve the right to make changes, corrections, enhancements, modifications, and improvements to ST products and/or to this document at any time without notice. Purchasers should obtain the latest relevant information on ST products before placing orders. ST products are sold pursuant to ST's terms and conditions of sale in place at the time of order acknowledgement.

Purchasers are solely responsible for the choice, selection, and use of ST products and ST assumes no liability for application assistance or the design of Purchasers' products.

No license, express or implied, to any intellectual property right is granted by ST herein.

Resale of ST products with provisions different from the information set forth herein shall void any warranty granted by ST for such product.

ST and the ST logo are trademarks of ST. All other product or service names are the property of their respective owners.

Information in this document supersedes and replaces information previously supplied in any prior versions of this document.

© 2015 STMicroelectronics – All rights reserved

