

## Features

- Two lane DisplayPort® 1.2a receiver
- Triple 8-bit video DAC
  - 162 MSPS throughput rate
  - VSIS compatible
  - RGB output with 0 to 700 mV range
- 3.3 V HSYNC, VSYNC
- Resolution through WUXGA
- EDID, MCCS pass-through support
- 3.3 V DDC output signals
- Sink detection logic
- Low power operation – Active 400 mW, standby mode 15 mW
- Package: 64-pin QFN, 6 x 6 mm

## Applications

- DisplayPort to VGA dongle as an attachment to notebook and desktop PCs
- DisplayPort to VGA conversion for notebook and desktop PC motherboard applications

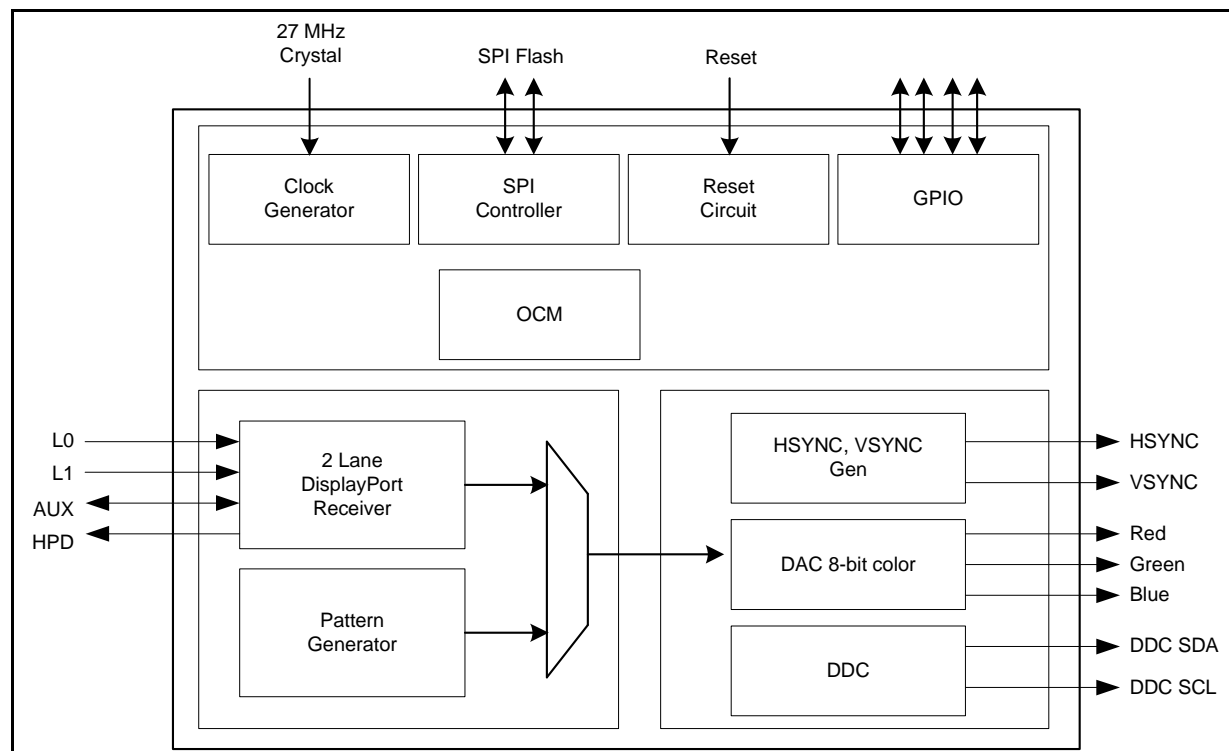

## 1. Description

STDP3160 is a DisplayPort to VGA signal format converter for interfacing DisplayPort based PC, notebook, tablet, and smart phones with conventional VGA displays. DisplayPort offers a unified, scalable, and cost effective interface for embedded and external display applications. As desktop and notebook PCs are increasingly transitioning from conventional analog type interfaces to DisplayPort, STDP3160 facilitates the transition by offering seamless connectivity between new DisplayPort PC, notebooks, and the installed base VGA monitors and projectors. Besides the dongle application, STDP3160 is also a perfect fit for the notebook and desktop motherboard designs based on new generation Intel, AMD CPU/GPU architecture. STDP3160 is a highly integrated converter featuring a DisplayPort receiver, video DAC, clock form generator, test pattern generator, and sink detection block. In addition, STDP3160 includes EDID and MCCS pass-through features, forming a fully transparent operation between the PC and display. Active power consumption of this device is as low as 400 mW, and thus it can be powered by the DisplayPort source when used in a dongle application. The device has a built-in sink detection feature that determines the active and standby state. The device enters into standby (low power) state whenever the VGA cable is disconnected and returns to normal operation when the cable is connected back.

STDP3160 supports video resolutions from VGA through WUXGA. The input DisplayPort interface consists of two main lanes, AUX channel, and HPD signal that maps directly to a standard DisplayPort connector via two layers PCB. The output interface consists of analog R, G, B video, Hsync, Vsync, and DDC signals. Analog video signal amplitude ranges from 0 to 700 mV from an 8-bit video DAC with maximum sampling frequency of 162 MHz. The VGA output signal interface conforms to the VSIS standards with separate Hsync and Vsync control signals. The DDC\_SDA and DDC\_CLK signals are driven from an I2C master, which controls I2C traffic between the DisplayPort AUX channel and external slave device.

MegaChips offers an STDP3160 designers kit with complete reference hardware and firmware.

**Figure 1. System diagram**

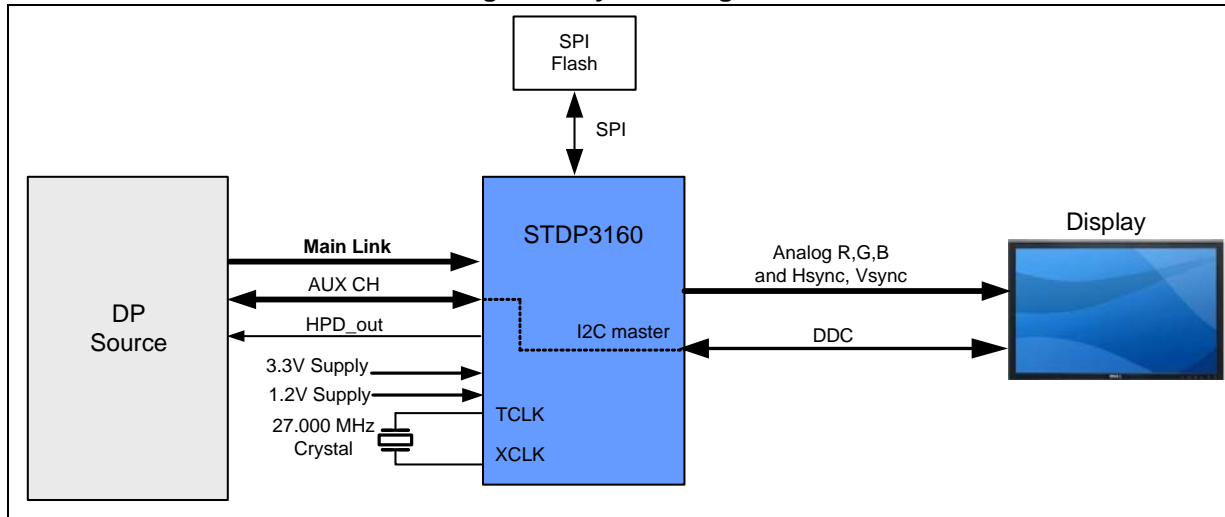

## 2. Benefits

- Production-proven DisplayPort receiver from the DisplayPort leader
- Comprehensive feature set for DisplayPort to VGA dongle and for notebook embedded application
- Proven interoperability with DisplayPort sources from all major graphics vendors
- Cost savings due to optimized BOM, low power, low EMI, and small form factor
- DisplayPort CTS compliant
- Windows based software tool for factory/field upgrade – programs over DP AUX channel

### 3. Feature attributes

- DisplayPort 1.2a compliant receiver offering 5.4 Gbps bandwidth over two lanes
- Integrated triple 8-bit, 162 MHz video DAC for analog VGA signal output
- Supports up to 1080p, 1920 x 1200 reduced blanking video resolution
- EDID and MCCS pass-through from PC source to display
- Spread spectrum (de-spreading) for EMI reduction
- Automatic sink detection
- Low power standby mode operation initiated based on sink detection status
- SPI interface with external Serial Flash for storing firmware and system configuration data for customization purposes
- Optional two-wire host interface for device configuration using external controller
- UART interface for chip debug and development purpose
- ISP over DP AUX channel
- General-purpose I/O pins for system usage
- Powered from DisplayPort source
- 3.3 V IO, 1.2 V Core
- 64-pin QFN (6 x 6 mm) package

## 4. Ordering information

**Table 1. Order codes**

Part number	Description
STDP3160-AB	64-pin QFN (6 x 6 mm)

## 5. Revision history

**Table 2. Document revision history**

Date	Revision	Changes
13-Jul-2012	A	Preliminary release.
30-Nov-2012	B	Updated silicon revision in Section 4: Ordering information.
11-Jan-2013	C	All instances of DisplayPort1.1a changed to DisplayPort1.2a.
16-May-2014	D	Updated to comply with MegaChips documentation style/formatting.
15-Sep-2014	E	Updated footers and added copyright information to last page.

### Notice

Semiconductor products may possibly experience breakdown or malfunction. Adequate care should be taken with respect to the safety design of equipment in order to prevent the occurrence of human injury, fire or social loss in the event of breakdown or malfunction of semiconductor products

The overview of operations and illustration of applications described in this document indicate the conceptual method of use of the semiconductor product and do not guarantee operability in equipment in which the product is actually used.

The names of companies and trademarks stated in this document are registered trademarks of the relevant companies.

MegaChips Co. provides no guarantees nor grants any implementation rights with respect to industrial property rights, intellectual property rights and other such rights belonging to third parties or/and MegaChips Co. in the use of products and of technical information including information on the overview of operations and the circuit diagrams that are described in this document.

The product described in this document may possibly be considered goods or technology regulated by the Foreign Currency and Foreign Trade Control Law. In the event such law applies, export license will be required under said law when exporting the product. This regulation shall be valid in Japan domestic.

In the event the intention is to use the product described in this document in applications that require an extremely high standard of reliability such as nuclear systems, aerospace equipment or medical equipment for life support, please contact the sales department of MegaChips Co. in advance.

All information contained in this document is subject to change without notice.

Copyright ©2014 MegaChips Corporation All rights reserved

**MegaChips Corporation**  
**Head Quarters**  
1-1-1 Miyahara, Yodogawa-ku Osaka 532-0003, Japan  
TEL: +81-6-6399-2884

**MegaChips Corporation**  
**Tokyo Office**  
17-6 Ichiban-cho, Chiyoda-ku, Tokyo 102-0082, Japan  
TEL: +81-3-3512-5080

**MegaChips Corporation**  
**Makuhari Office**  
1-3 Nakase Mihama-ku Chiba 261-8501, Japan  
TEL: +81-43-296-7414

**MegaChips Corporation**  
**San Jose Office**  
2033 Gateway Place, Suite 400, San Jose, CA 95110 U.S.A.  
TEL: +1-408-570-0555

**MegaChips Corporation**  
**India Branch**  
17th Floor, Concorde Block UB City,  
Vittal Mallya Road, Bangalore 560-001, India  
TEL: +91-80-4041-3999

**MegaChips Corporation**  
**Taiwan Branch**  
RM. B 2F, Worldwide House, No.129,  
Min Sheng E. Rd., Sec. 3, Taipei 105, Taiwan  
TEL: +886-2-2547-1297

**MegaChips Corporation**  
**Tainan Office**  
RM. 2, 8F, No.24, Da Qiao 2 Rd., Yong Kang Dist.,  
Tainan 710, Taiwan  
TEL: +886-6-302-2898

**MegaChips Corporation**  
**Zhunan Office**  
No.118, Chung-Hua Rd., Chu-Nan, Miao-Li 350, Taiwan  
TEL: +886-37-666-156

**MegaChips Corporation**  
**Shenzhen Office**  
Room 6307, Office Tower, Shun Hing Square, 5002  
Shen Nan Dong Road, Luohu District,  
Shenzhen 518000, P. R. China  
TEL: +86-755-3664-6990