

150 W HID digital ballast based on the STLUX385A

Data brief

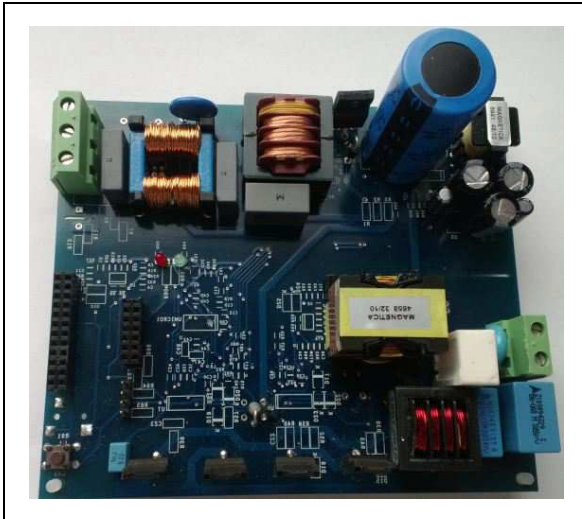

Features

- Input voltage: 185 - 265 Vac
- Rated lamp power: 150 W
- Efficiency: > 92.5%
- Power Factor: > 0.996
- Input current THD: < 10%
- Overtemperature protection for the electronics
- Open load detection
- Short-circuit protection
- Input overvoltage protection
- EMI: EN55015 pre-compliance
- PLM remote control ready

Description

The STEVAL-ILH007V1 evaluation board is a 150 W high intensity discharge (HID) digital ballast platform based on the STLUX385A digital controller.

This solution is designed to drive sodium and metal halide HID lamps. The board is composed of two stages, the power factor corrector (PFC) and the inverter.

The PFC is based on a boost topology to correct the AC input current in phase with the AC voltage mains. The inverter is based on a full bridge topology to drive the lamps. The STLUX385A digital controller drives both stages.

The STLUX385A device is part of the STLUX™ family of STMicroelectronics digital devices tailored for lighting and power conversion applications.

The heart of the STLUX is the SMED (state machine, event driven) technology which allows the device to operate several independently-configurable PWM clocks with up to 1.3 ns resolution. A SMED is a powerful autonomous state machine which is programmed to react to both external and internal events and may evolve without any software intervention. The SMED even reaction time can be as low as 10 ns, giving the STLUX the ability of operating in time critical applications. The SMEDs are configured and programmed via the STLUX internal low-power microcontroller (STM8 for the STLUX385A).

The STEVAL-ILH007V1 is designed to receive commands by the PLM remote control unit, to create a network for street lighting based on power line communication.

Figure 2. Full bridge electric scheme

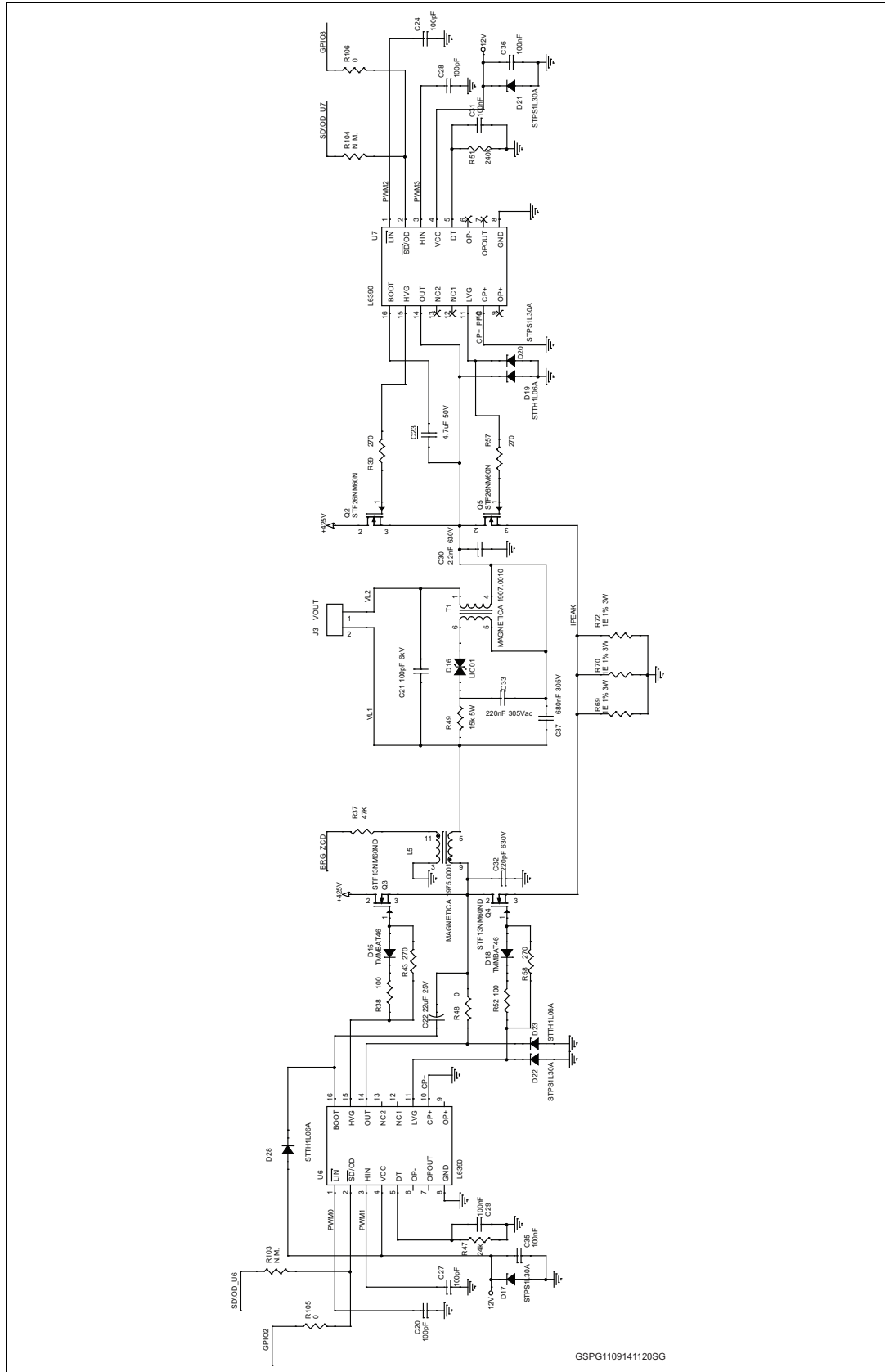

GSPG11091411205G



Figure 3. Control section electric scheme

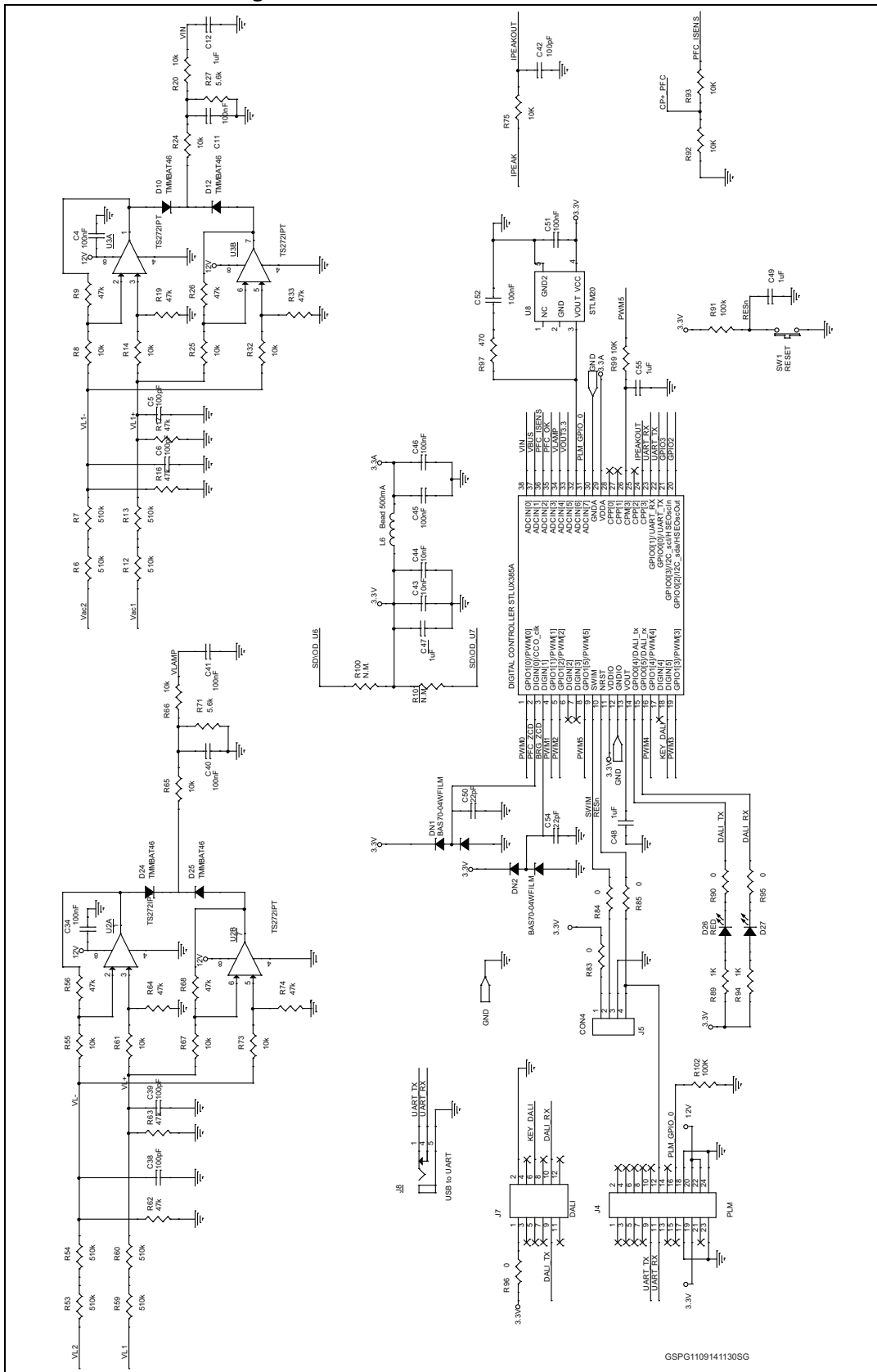

GSPG1109141130SG



Figure 4. Auxiliary power supply electric scheme

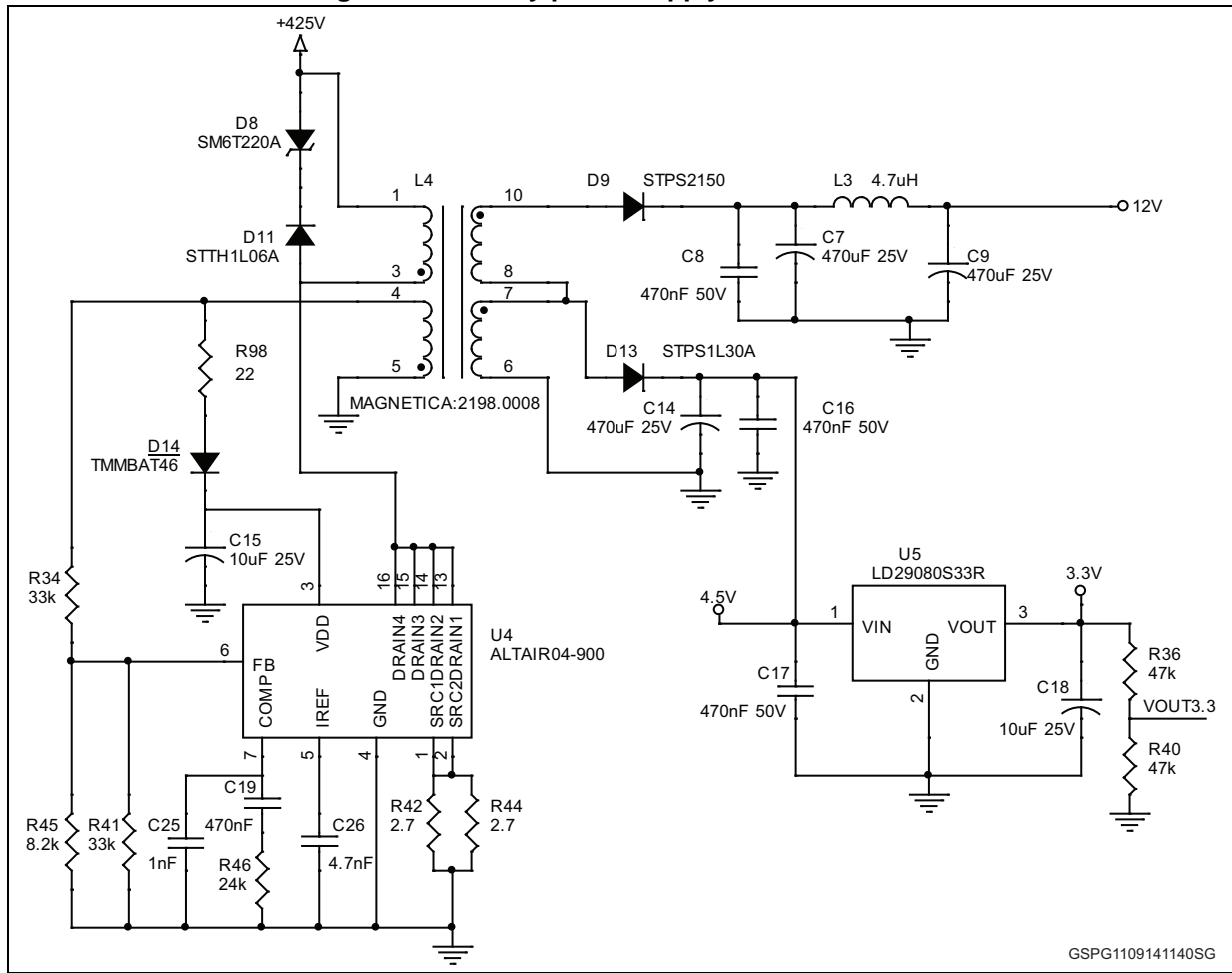

2 Revision history

Table 1. Document revision history

Date	Revision	Changes
15-Jan-2014	1	Initial release.
11-Sep-2014	2	Updated features and description in cover page.
18-Sep-2014	3	Updated: – <i>Figure 1 on page 2</i> and <i>Figure 2 on page 3</i> Added: – <i>Figure 3 on page 4</i> and <i>Figure 4 on page 5</i>

IMPORTANT NOTICE – PLEASE READ CAREFULLY

STMicroelectronics NV and its subsidiaries ("ST") reserve the right to make changes, corrections, enhancements, modifications, and improvements to ST products and/or to this document at any time without notice. Purchasers should obtain the latest relevant information on ST products before placing orders. ST products are sold pursuant to ST's terms and conditions of sale in place at the time of order acknowledgement.

Purchasers are solely responsible for the choice, selection, and use of ST products and ST assumes no liability for application assistance or the design of Purchasers' products.

No license, express or implied, to any intellectual property right is granted by ST herein.

Resale of ST products with provisions different from the information set forth herein shall void any warranty granted by ST for such product.

ST and the ST logo are trademarks of ST. All other product or service names are the property of their respective owners.

Information in this document supersedes and replaces information previously supplied in any prior versions of this document.

© 2014 STMicroelectronics – All rights reserved

