

MEMS audio sensor high-performance analog bottom-port microphone

Datasheet - production data



Description

The MP23AB02B is a compact, low-power microphone built with a low-profile sensing element.

The sensing element, capable of detecting acoustic waves, is manufactured using a specialized silicon micromachining process to produce audio sensors.

The MP23AB02B has an acoustic overload point of 125 dB SPL with a 64 dB signal-to-noise ratio.

The MP23AB02B is available in a package compliant with reflow soldering and is guaranteed to operate over an extended temperature range from -40 °C to +85 °C.

Features

- Single supply voltage operation
- Low power consumption
- Omnidirectional sensitivity
- High signal-to-noise ratio
- High bandwidth
- Package compliant with reflow soldering

Table 1. Device summary

Order code	Temperature range (°C)	Package	Packing
MP23AB02B	-40 to +85	(3.35 x 2.5 x 0.98) mm	Tray
MP23AB02BTR	-40 to +85	(3.35 x 2.5 x 0.98) mm	Tape and reel

1 Pin description

Figure 1. Pin connections

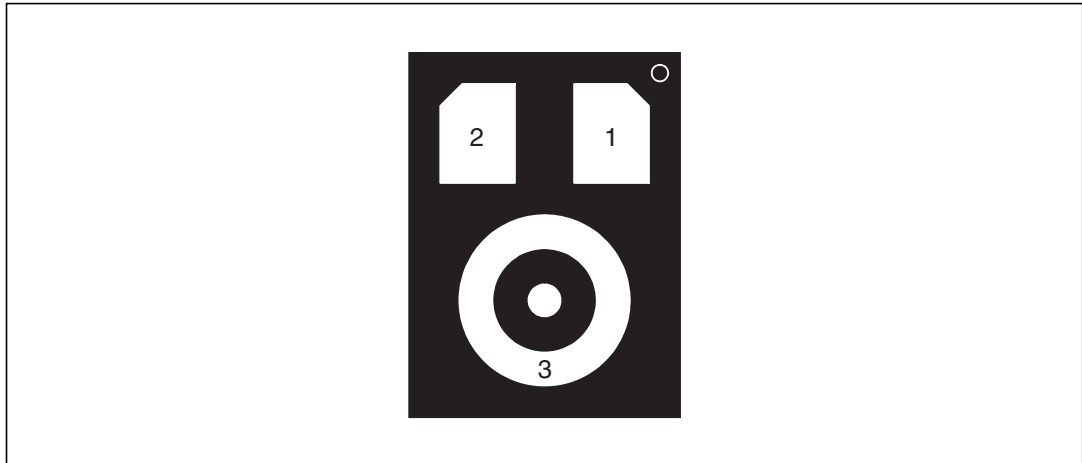

Table 2. Pin description

Pin n°	Pin name	Function
1	Out	Analog output
2	Vdd	Power supply
3	GND	Ground

2 Acoustic and electrical specifications

2.1 Acoustic and electrical characteristics

The values listed in the table below are specified for $V_{dd} = 1.8\text{ V}$, $T_{amb} = 25\text{ °C}$ unless otherwise specified.

Table 3. Acoustic and electrical characteristics

Symbol	Parameter	Test condition	Min.	Typ. ⁽¹⁾	Max.	Unit
Vdd	Supply voltage		1.6	1.8	3.6	V
Idd	Current consumption	mean value = 2 V		150	220	μA
So	Sensitivity	1 kHz (0 dB = 1 V/Pa)	-41	-38	-35	dBV/PA
SNR	Signal-to-noise ratio	A-weighted, 1 kHz (0 dB = 1 V/Pa)		64		dB
Top	Operating temperature range		-40		+85	°C

1. Typical specifications are not guaranteed

Table 4. Distortion specifications at 1 kHz

Parameter	Test condition	Value
Distortion	94	< 0.5%
Distortion	120	< 2%
Distortion	124	= 10%

Figure 2. Frequency response

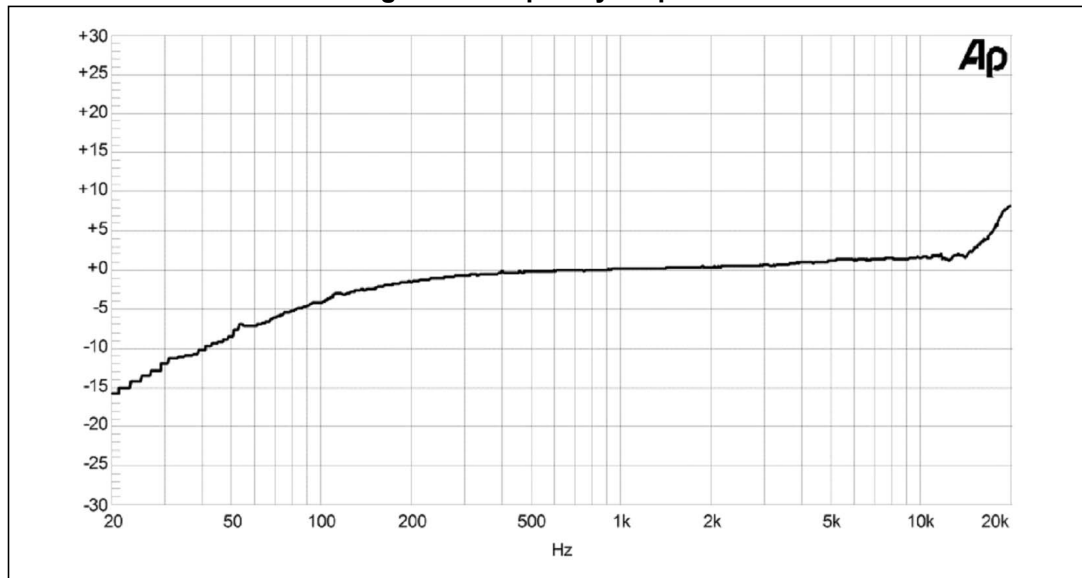

3 Absolute maximum ratings

Stresses above those listed as “Absolute maximum ratings” may cause permanent damage to the device. This is a stress rating only and functional operation of the device under these conditions is not implied. Exposure to maximum rating conditions for extended periods may affect device reliability.

Table 5. Absolute maximum ratings

Symbol	Ratings	Maximum value	Unit
V _{dd}	Supply voltage	-0.5 to 4	V
T _{STG}	Storage temperature range	-40 to +125	°C



This device is sensitive to mechanical shock, improper handling can cause permanent damage to the part.



This device is sensitive to electrostatic discharge (ESD), improper handling can cause permanent damage to the part.

4 Application recommendations

Figure 3. MP23AB02B electrical connections and external component values

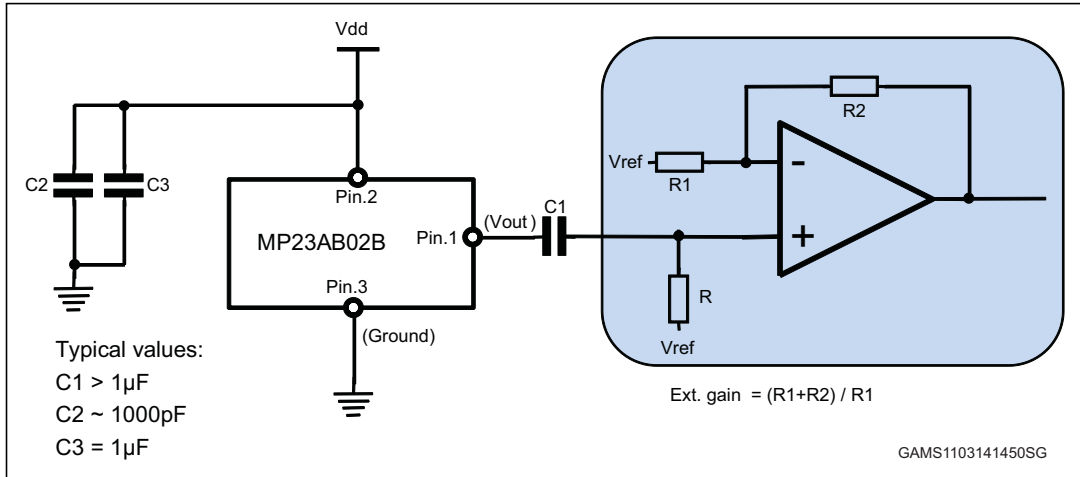

5 Package mechanical data

In order to meet environmental requirements, ST offers these devices in different grades of ECOPACK[®] packages, depending on their level of environmental compliance. ECOPACK[®] specifications, grade definitions and product status are available at: www.st.com. ECOPACK[®] is an ST trademark.

Figure 4. RHLGA metal cap 3-lead 3.35 mm x 2.5 mm x 0.98 mm package outline

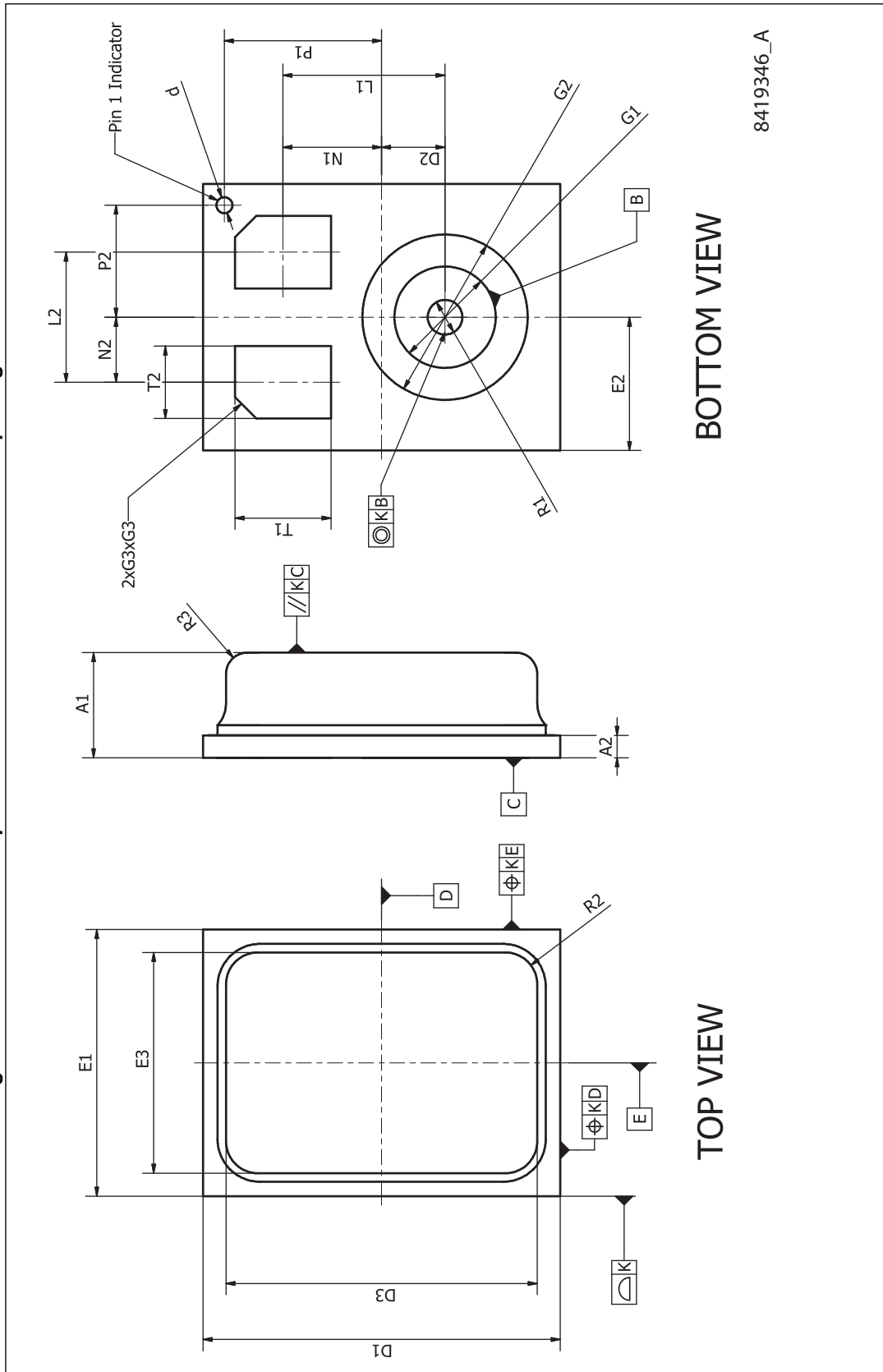
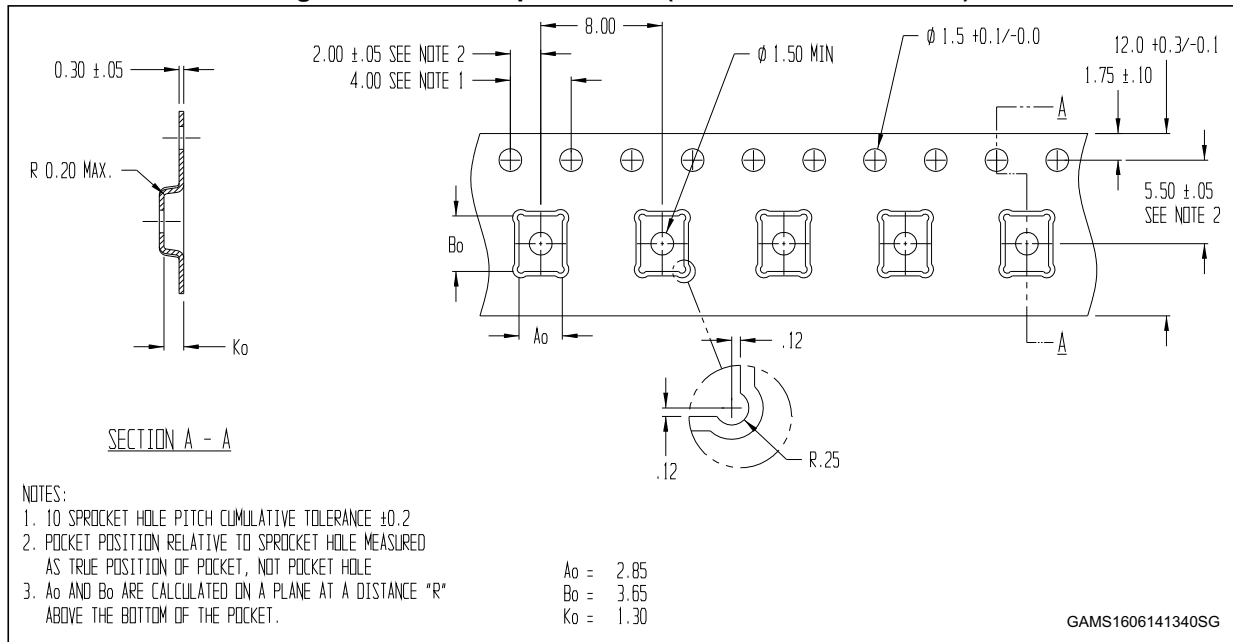

Table 6. RHLGA metal cap 3-lead (3.35 x 2.5 x 0.98 mm⁹ package dimensions

Reference	Dimensions (mm)		
	Min.	Typ.	Max.
A1	0.880	0.980	1.080
A2	0.200	0.250	0.300
D1	3.250	3.350	3.450
D2	0.495	0.595	0.695
D3	2.770	2.920	3.070
R1	0.275	0.325	0.375
R2		0.28	
R3		0.25	
E1	2.400	2.500	2.600
E2	1.150	1.250	1.350
E3	1.920	2.070	2.220
L1	1.480	1.520	1.560
L2	1.180	1.220	1.260
N1	0.885	0.925	0.965
N2	0.570	0.610	0.650
T1	0.860	0.900	0.940
T2	0.640	0.680	0.720
G1	0.900	0.950	1.000
G2	1.400	1.550	1.600
G3	0.100	0.150	0.200
P1	1.425	1.475	1.525
P2	1.000	1.050	1.100
d		0.150	
K		0.050	

Figure 5. RHLGA tape and reel (dimensions are in mm.)



6 Soldering information

Figure 6. Recommended soldering profile limits

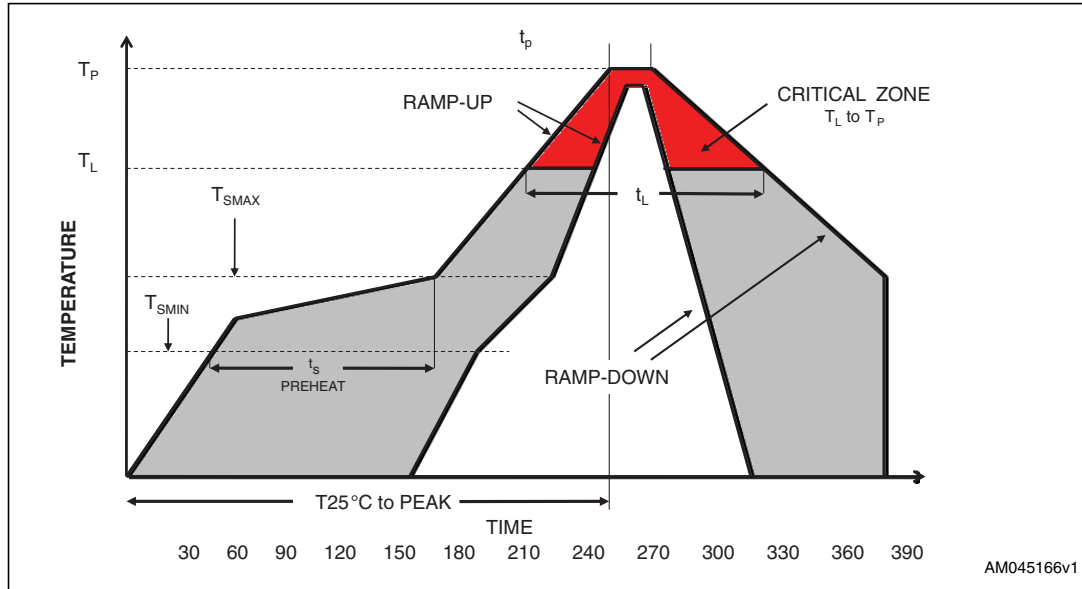

Table 7. Recommended soldering profile limits

Description	Parameter	Pb free
Average ramp rate	T_L to T_P	3 °C/sec max
Preheat		
Minimum temperature	T_{SMIN}	150 °C
Maximum temperature	T_{SMAX}	200 °C
Time (T_{SMIN} to T_{SMAX})	t_s	60 sec to 120 sec
Ramp-up rate	T_{SMAX} to T_L	
Time maintained above liquidus temperature	t_L	60 sec to 150 sec
Liquidus temperature	T_L	217 °C
Peak temperature	T_P	260 °C max
Time within 5 °C of actual peak temperature		20 sec to 40 sec
Ramp-down rate		6 °C/sec max
Time 25 °C ($t = 25$ °C) to peak temperature		8 minutes max

7 Revision history

Table 8. Document revision history

Date	Revision	Changes
21-Mar-2014	1	Initial release.
16-Jun-2014	2	Updated <i>Figure 5 on page 9</i> .
22-Sep-2014	3	Updated acoustic overload point in <i>Description</i> .

IMPORTANT NOTICE – PLEASE READ CAREFULLY

STMicroelectronics NV and its subsidiaries ("ST") reserve the right to make changes, corrections, enhancements, modifications, and improvements to ST products and/or to this document at any time without notice. Purchasers should obtain the latest relevant information on ST products before placing orders. ST products are sold pursuant to ST's terms and conditions of sale in place at the time of order acknowledgement.

Purchasers are solely responsible for the choice, selection, and use of ST products and ST assumes no liability for application assistance or the design of Purchasers' products.

No license, express or implied, to any intellectual property right is granted by ST herein.

Resale of ST products with provisions different from the information set forth herein shall void any warranty granted by ST for such product.

ST and the ST logo are trademarks of ST. All other product or service names are the property of their respective owners.

Information in this document supersedes and replaces information previously supplied in any prior versions of this document.

© 2014 STMicroelectronics – All rights reserved