

REVISIONS			
LTR	DESCRIPTION	DATE (YR-MO-DA)	APPROVED
A	Add device type 02. Add vendor CAGE 01295. Change to one part one part number format. Add ground bounce and latch-up immunity tests. Add 10.1 substitution statement. Changes to table I. Editorial corrections throughout. - jak	92-07-09	Monica L. Poelking
B	Change in accordance with NOR 5962-R042-93 - tjr	92-12-29	Monica L. Poelking
C	Change in accordance with NOR 5962-R196-95 – jak	95-09-13	Monica L. Poelking
D	Add device type 03. Add vendor CAGE F8859. Add case outlines X. Add radiation features for device type 01. Update boilerplate to MIL-PRF-38535 requirements. - jak	02-12-18	Thomas M. Hess
E	Add radiation features for device type 03 in section 1.5. Update the boilerplate to include radiation hardness assured requirements for device type 03. Editorial changes throughout. - jak	05-03-15	Thomas M. Hess
F	Update boilerplate to current MIL-PRF-38535 requirements and to include radiation hardness assurance requirements. Add appendix A to document. - LTG	07-05-25	Thomas M. Hess

REV																				
SHEET																				
REV	F	F	F	F	F	F	F	F	F	F	F	F	F	F	F	F	F	F	F	F
SHEET	15	16	17	18	19	20	21	22	23	24	25	26	27	28	29	30	31	32		
REV STATUS OF SHEETS	REV			F	F	F	F	F	F	F	F	F	F	F	F	F	F	F	F	F
	SHEET			1	2	3	4	5	6	7	8	9	10	11	12	13	14			
PMIC N/A	PREPARED BY Greg Pitz				<b>DEFENSE SUPPLY CENTER COLUMBUS</b> <b>COLUMBUS, OHIO 43218-3990</b> <a href="http://www.dsc.dla.mil">http://www.dsc.dla.mil</a>  MICROCIRCUIT, DIGITAL, ADVANCED CMOS, OCTAL TRANSCEIVER WITH THREE-STATE OUTPUTS, TTL COMPATIBLE INPUTS, MONOLITHIC SILICON															
<b>STANDARD MICROCIRCUIT DRAWING</b>  THIS DRAWING IS AVAILABLE FOR USE BY ALL DEPARTMENTS AND AGENCIES OF THE DEPARTMENT OF DEFENSE  AMSC N/A	CHECKED BY D. A. DiCenzo																			
	APPROVED BY N. A. Hauck																			
	DRAWING APPROVAL DATE 87-08-06																			
	REVISION LEVEL F																			
	SIZE A	CAGE CODE 67268	5962-87663																	
	SHEET 1 OF 32																			



1.3 Absolute maximum ratings. 1/ 2/

Supply voltage range ( $V_{CC}$ ) .....	-0.5 V dc to +6.0 V dc
DC input voltage ( $V_{IN}$ ) .....	-0.5 V dc to $V_{CC} + 0.5$ V dc
DC output voltage range ( $V_{OUT}$ ) .....	-0.5 V dc to $V_{CC} + 0.5$ V dc
Clamp diode current ( $I_{IK}, I_{OK}$ ).....	$\pm 20$ mA
DC output current ( $I_{OUT}$ ) .....	$\pm 50$ mA
DC $V_{CC}$ or GND current ( $I_{CC}, I_{GND}$ ).....	$\pm 200$ mA 3/
Storage temperature range ( $T_{STG}$ ) .....	-65°C to +150°C
Maximum power dissipation ( $P_D$ ).....	500 mW
Lead temperature (soldering, 10 seconds):	
Case outline X.....	+260°C
All other case outlines except case X .....	+300°C
Thermal resistance, junction-to-case ( $\theta_{JC}$ ) .....	See MIL-STD-1835
Junction temperature ( $T_J$ ).....	+175°C
Case operating temperature ( $T_C$ ) .....	-55°C to +125°C

1.4 Recommended operating conditions. 2/ 4/

Supply voltage range ( $V_{CC}$ ) .....	+4.5 V dc to +5.5 V dc
Input voltage range ( $V_{IN}$ ) .....	+0.0 V dc to $V_{CC}$
Output voltage range ( $V_{OUT}$ ).....	+0.0 V dc to $V_{CC}$
Maximum low level input voltage ( $V_{IL}$ ):	
$V_{CC} = 4.5$ V.....	0.8 V
$V_{CC} = 5.5$ V.....	0.8 V
Minimum high level input voltage ( $V_{IH}$ ):	
$V_{CC} = 4.5$ V.....	2.0 V
$V_{CC} = 5.5$ V.....	2.0 V
Case operating temperature range ( $T_C$ ) .....	-55°C to +125°C
Input rise and fall rate ( $t_r$ and $t_f$ ) maximum:	
$V_{CC} = 4.5$ V.....	10 ns/V
$V_{CC} = 5.5$ V.....	8 ns/V
Maximum high level output current ( $I_{OH}$ ) .....	-24 mA
Maximum low level output current ( $I_{OL}$ ) .....	24 mA

1.5 Radiation features.

Device type 01:	
Maximum total dose available (dose rate = 50 – 300 rads (Si)/s).....	100 Krads (Si)
Single Event Latch-up (SEL) .....	$\geq 120$ MeV-cm <sup>2</sup> /mg 5/
Device type 03:	
Maximum total dose available (dose rate = 50 – 300 rads (Si)/s).....	300 krads (Si)
Single Event Latch-up (SEL) .....	$\geq 93$ MeV-cm <sup>2</sup> /mg 5/

- 1/ Stresses above the absolute maximum rating may cause permanent damage to the device. Extended operation at the maximum levels may degrade performance and affect reliability. The maximum junction temperature may be exceeded for allowable short duration burn-in screening conditions in accordance with method 5004 of MIL-STD-883.
- 2/ Unless otherwise noted, all voltages are referenced to GND.
- 3/ For packages with multiple  $V_{CC}$  and GND pins, this value represents the maximum total current flowing into or out of all  $V_{CC}$  or GND pins.
- 4/ Unless otherwise specified, the values listed above shall apply over the full  $V_{CC}$  and  $T_C$  recommended operating range.
- 5/ Limits are guaranteed by design or process, but not production tested unless specified by the customer through the purchase order or contract.

<b>STANDARD MICROCIRCUIT DRAWING</b> DEFENSE SUPPLY CENTER COLUMBUS COLUMBUS, OHIO 43218-3990	SIZE <b>A</b>		<b>5962-87663</b>
		REVISION LEVEL <b>F</b>	SHEET <b>3</b>

2. APPLICABLE DOCUMENTS

2.1 Government specification, standards, and handbooks. The following specification, standards, and handbooks form a part of this drawing to the extent specified herein. Unless otherwise specified, the issues of these documents are those cited in the solicitation or contract.

DEPARTMENT OF DEFENSE SPECIFICATION

MIL-PRF-38535 - Integrated Circuits, Manufacturing, General Specification for.

DEPARTMENT OF DEFENSE STANDARDS

MIL-STD-883 - Test Method Standard Microcircuits.  
 MIL-STD-1835 - Interface Standard Electronic Component Case Outlines.

DEPARTMENT OF DEFENSE HANDBOOKS

MIL-HDBK-103 - List of Standard Microcircuit Drawings.  
 MIL-HDBK-780 - Standard Microcircuit Drawings.

(Copies of these documents are available online at <http://assist.daps.dla.mil/quicksearch/> or <http://assist.daps.dla.mil> or from the Standardization Document Order Desk, 700 Robbins Avenue, Building 4D, Philadelphia, PA 19111-5094.)

2.2 Non-Government publications. The following document(s) form a part of this document to the extent specified herein. Unless otherwise specified, the issues of these documents are those cited in the solicitation or contract.

ELECTRONIC INDUSTRIES ALLIANCE (EIA)

EIA/JEDEC Standard No. 78 - IC Latch-up Test  
 JEDEC Standard No. 20 - Standard for Description of 54/74ACXXXX and 54/74ACTXXXX Advanced High-Speed CMOS Devices.

(Copies of these documents are available online at <http://www.jedec.org> or from Electronic Industries Alliance, 2500 Wilson Boulevard, Arlington, VA 22201-3834.)

AMERICAN SOCIETY FOR TESTING AND MATERIALS (ASTM)

ASTM F1192 - Standard Guide for the Measurement of Single Event Phenomena (SEP) Induced by Heavy Ion Irradiation of semiconductor Devices.

(Copies of these documents are available online at <http://www.astm.org> or from ASTM International, 100 Barr Harbor Drive, P.O. Box C700, West Conshohocken, PA 19428-2959).

2.3 Order of precedence. In the event of a conflict between the text of this drawing and the references cited herein, the text of this drawing takes precedence. Nothing in this document, however, supersedes applicable laws and regulations unless a specific exemption has been obtained.

3. REQUIREMENTS

3.1 Item requirements. The individual item requirements for device classes B, S, Q, and V shall be in accordance with MIL-PRF-38535 and as specified herein or as modified in the device manufacturer's Quality Management (QM) plan. The modification in the QM plan shall not affect the form, fit, or function as described herein. The individual item requirements for device class M shall be in accordance with MIL-PRF-38535, appendix A for non-JAN class level B devices and as specified herein.

3.1.1 Microcircuit die. For the requirements of microcircuit die, see appendix A to this document.

<b>STANDARD                  MICROCIRCUIT DRAWING</b> DEFENSE SUPPLY CENTER COLUMBUS COLUMBUS, OHIO 43218-3990	SIZE <b>A</b>		<b>5962-87663</b>
		REVISION LEVEL F	SHEET 4

3.2 Design, construction, and physical dimensions. The design, construction, and physical dimensions shall be as specified in MIL-PRF-38535 and herein for device classes B, S, Q, and V or MIL-PRF-38535, appendix A and herein for device class M.

3.2.1 Case outlines. The case outlines shall be in accordance with 1.2.4 and figure 1, herein.

3.2.2 Terminal connections. The terminal connections shall be as specified on figure 2.

3.2.3 Truth table. The truth table shall be as specified on figure 3.

3.2.4 Logic diagram. The logic diagram shall be as specified on figure 4.

3.2.5 Ground bounce waveforms and test circuit. The ground bounce waveforms and test circuit shall be as specified on figure 5.

3.2.6 Switching waveforms and test circuit. The switching waveforms and test circuit shall be as specified on figure 6.

3.2.7 Radiation exposure circuit. The radiation exposure circuit shall be maintained by the manufacturer under document revision level control and shall be made available to the preparing and acquiring activity upon request.

3.3 Electrical performance characteristics and postirradiation parameter limits. Unless otherwise specified herein, the electrical performance characteristics and postirradiation parameter limits are as specified in table IA and shall apply over the full case operating temperature range. Test conditions for these specified characteristics and limits are as specified in table IA.

3.4 Electrical test requirements. The electrical test requirements shall be the subgroups specified in table IIA. The electrical tests for each subgroup are defined in table IA.

3.5 Marking. The part shall be marked with the PIN listed in 1.2 herein. In addition, the manufacturer's PIN may also be marked. For packages where marking of the entire SMD PIN number is not feasible due to space limitations, the manufacturer has the option of not marking the "5962-" on the device. For RHA product using this option, the RHA designator shall still be marked. Marking for device classes B, S, Q, and V shall be in accordance with MIL-PRF-38535. Marking for device class M shall be in accordance with MIL-PRF-38535, appendix A.

3.5.1 Certification/compliance mark. The certification mark for device classes B, S, Q, and V shall be a "QML" or "Q" as required in MIL-PRF-38535. The compliance mark for device class M shall be a "C" as required in MIL-PRF-38535, appendix A.

3.6 Certificate of compliance. For device classes B, S, Q, and V, a certificate of compliance shall be required from a QML-38535 listed manufacturer in order to supply to the requirements of this drawing (see 6.6.1 herein). For device class M, a certificate of compliance shall be required from a manufacturer in order to be listed as an approved source of supply in MIL-HDBK-103 (see 6.6.2 herein). The certificate of compliance submitted to DSCC-VA prior to listing as an approved source of supply for this drawing shall affirm that the manufacturer's product meets, for device classes B, S, Q, and V, the requirements of MIL-PRF-38535 and herein or for device class M, the requirements of MIL-PRF-38535, appendix A and herein.

3.7 Certificate of conformance. A certificate of conformance as required for device classes B, S, Q, and V in MIL-PRF-38535 or for device class M in MIL-PRF-38535, appendix A shall be provided with each lot of microcircuits delivered to this drawing.

3.8 Notification of change for device class M. For device class M, notification to DSCC-VA of change of product (see 6.2 herein) involving devices acquired to this drawing is required for any change that affects this drawing.

3.9 Verification and review for device class M. For device class M, DSCC, DSCC's agent, and the acquiring activity retain the option to review the manufacturer's facility and applicable required documentation. Offshore documentation shall be made available onshore at the option of the reviewer.

3.10 Microcircuit group assignment for device class M. Device class M devices covered by this drawing shall be in microcircuit group number 37 (see MIL-PRF-38535, appendix A).

<b>STANDARD MICROCIRCUIT DRAWING</b> DEFENSE SUPPLY CENTER COLUMBUS COLUMBUS, OHIO 43218-3990	SIZE <b>A</b>		<b>5962-87663</b>
		REVISION LEVEL F	SHEET 5

TABLE IA. Electrical performance characteristics.

Test and MIL-STD-883 test method <u>1/</u>	Symbol	Test Conditions <u>2/ 3/</u> -55°C ≤ T <sub>C</sub> ≤ +125°C +4.5 V ≤ V <sub>CC</sub> ≤ +5.5 V unless otherwise specified	Device type <u>4/</u> and device class	V <sub>CC</sub>	Group A subgroups	Limits <u>5/</u>		Unit
						Min	Max	
High level output voltage 3006	V <sub>OH1</sub> <u>6/</u>	For all inputs affecting output under test, V <sub>IN</sub> = V <sub>IH</sub> or V <sub>IL</sub> V <sub>IH</sub> = 2.0 V V <sub>IL</sub> = 0.8 V For all other inputs, V <sub>IN</sub> = V <sub>CC</sub> or GND I <sub>OH</sub> = -50 μA	All All	4.5 V	1, 2, 3	4.4		V
	V <sub>OH2</sub> <u>7/ 8/</u>	For all inputs affecting output under test, V <sub>IN</sub> = V <sub>IH</sub> or V <sub>IL</sub> V <sub>IH</sub> = 2.0 V V <sub>IL</sub> = 0.8 V For all other inputs, V <sub>IN</sub> = V <sub>CC</sub> or GND I <sub>OH</sub> = -50 μA	M	01	5.5 V	1, 2, 3	5.4	
			D	B, S, Q, V				
			P, L, R					
	V <sub>OH3</sub> <u>7/ 8/</u>	For all inputs affecting output under test, V <sub>IN</sub> = V <sub>IH</sub> or V <sub>IL</sub> V <sub>IH</sub> = 2.0 V V <sub>IL</sub> = 0.8 V For all other inputs, V <sub>IN</sub> = V <sub>CC</sub> or GND I <sub>OH</sub> = -24 mA	M	01	4.5 V	1, 2, 3	3.7	
			D	B, S, Q, V				
			P, L, R					
	V <sub>OH4</sub> <u>6/</u>	For all inputs affecting output under test, V <sub>IN</sub> = V <sub>IH</sub> or V <sub>IL</sub> V <sub>IH</sub> = 2.0 V V <sub>IL</sub> = 0.8 V For all other inputs, V <sub>IN</sub> = V <sub>CC</sub> or GND I <sub>OH</sub> = -24 mA	All All		5.5 V	1, 2, 3	4.7	
	V <sub>OH5</sub> <u>7/ 8/ 9/</u>	For all inputs affecting output under test, V <sub>IN</sub> = V <sub>IH</sub> or V <sub>IL</sub> V <sub>IH</sub> = 2.0 V V <sub>IL</sub> = 0.8 V For all other inputs, V <sub>IN</sub> = V <sub>CC</sub> or GND I <sub>OH</sub> = -50 mA	M	01	5.5 V	1, 2, 3	3.85	
			D	B, S, Q, V				
P, L, R								

See footnotes at end of table.

**STANDARD  
MICROCIRCUIT DRAWING**  
DEFENSE SUPPLY CENTER COLUMBUS  
COLUMBUS, OHIO 43218-3990

SIZE  
**A**

REVISION LEVEL  
**F**

**5962-87663**

SHEET  
**6**

TABLE IA. Electrical performance characteristics - Continued.

Test and MIL-STD-883 test method <u>1/</u>	Symbol	Test Conditions <u>2/ 3/</u> -55°C ≤ T <sub>C</sub> ≤ +125°C +4.5 V ≤ V <sub>CC</sub> ≤ +5.5 V unless otherwise specified	Device type <u>4/</u> and device class	V <sub>CC</sub>	Group A subgroups	Limits <u>5/</u>		Unit		
						Min	Max			
Low level output voltage 3007	V <sub>OL1</sub> <u>6/</u>	For all inputs affecting output under test, V <sub>IN</sub> = V <sub>IH</sub> or V <sub>IL</sub> V <sub>IH</sub> = 2.0 V V <sub>IL</sub> = 0.8 V For all other inputs, V <sub>IN</sub> = V <sub>CC</sub> or GND I <sub>OL</sub> = 50 μA	All All	4.5 V	1, 2, 3		0.1	V		
	V <sub>OL2</sub> <u>7/ 8/</u>	For all inputs affecting output under test, V <sub>IN</sub> = V <sub>IH</sub> or V <sub>IL</sub> V <sub>IH</sub> = 2.0 V V <sub>IL</sub> = 0.8 V For all other inputs, V <sub>IN</sub> = V <sub>CC</sub> or GND I <sub>OL</sub> = 50 μA	All	5.5 V	1, 2, 3		0.1			
			M					01	1	0.1
			D P, L, R					B, S, Q, V		0.1 0.1
	V <sub>OL3</sub> <u>7/ 8/</u>	For all inputs affecting output under test, V <sub>IN</sub> = V <sub>IH</sub> or V <sub>IL</sub> V <sub>IH</sub> = 2.0 V V <sub>IL</sub> = 0.8 V For all other inputs, V <sub>IN</sub> = V <sub>CC</sub> or GND I <sub>OL</sub> = 24 mA	All	4.5 V	1, 3		0.4			
			B, S, Q, V						2	0.5
			All						1	0.4
			M						2, 3	0.5
			M					01	1	0.4
			D P, L, R					B, S, Q, V		0.4 0.4
	V <sub>OL4</sub> <u>6/</u>	For all inputs affecting output under test, V <sub>IN</sub> = V <sub>IH</sub> or V <sub>IL</sub> V <sub>IH</sub> = 2.0 V V <sub>IL</sub> = 0.8 V For all other inputs, V <sub>IN</sub> = V <sub>CC</sub> or GND I <sub>OL</sub> = 24 mA	All	5.5 V	1, 3		0.4			
			B, S, Q, V						2	0.5
			All						1	0.4
			M						2, 3	0.5
	V <sub>OL5</sub> <u>7/ 8/ 9/</u>	For all inputs affecting output under test, V <sub>IN</sub> = V <sub>IH</sub> or V <sub>IL</sub> V <sub>IH</sub> = 2.0 V V <sub>IL</sub> = 0.8 V For all other inputs, V <sub>IN</sub> = V <sub>CC</sub> or GND I <sub>OL</sub> = 50 mA	All	5.5 V	1, 2, 3		1.65			
All								1	1.65	
M			01						1.65	
D P, L, R			B, S, Q, V						1.65	

See footnotes at end of table.

<b>STANDARD MICROCIRCUIT DRAWING</b> DEFENSE SUPPLY CENTER COLUMBUS COLUMBUS, OHIO 43218-3990	SIZE <b>A</b>		<b>5962-87663</b>
		REVISION LEVEL <b>F</b>	SHEET <b>7</b>

TABLE IA. Electrical performance characteristics - Continued.

Test and MIL-STD-883 test method <u>1/</u>	Symbol	Test Conditions <u>2/ 3/</u> -55°C ≤ T <sub>C</sub> ≤ +125°C +4.5 V ≤ V <sub>CC</sub> ≤ +5.5 V unless otherwise specified	Device type <u>4/</u> and device class	V <sub>CC</sub>	Group A subgroups	Limits <u>5/</u>		Unit
						Min	Max	
Three-state output leakage current high 3021	I <sub>OZH</sub> <u>7/ 8/</u> <u>10/</u>	OE = V <sub>IH</sub> or V <sub>IL</sub> V <sub>IH</sub> = 2.0 V V <sub>IL</sub> = 0.8 V For all other inputs, V <sub>IN</sub> = V <sub>CC</sub> or GND V <sub>OUT</sub> = 5.5 V	All	5.5 V	1		0.6	μA
			B, S, Q, V		2		11.0	
			All		1		0.6	
			M		2, 3		11.0	
			M		1		3.0	
			D				10.0	
			P, L, R				20.0	
M, D, P, L, R, F	03		5.0					
		Q, V						
Three-state output leakage current low 3020	I <sub>OZL</sub> <u>7/ 8/</u> <u>10/</u>	OE = V <sub>IH</sub> or V <sub>IL</sub> V <sub>IH</sub> = 2.0 V V <sub>IL</sub> = 0.8 V For all other inputs, V <sub>IN</sub> = V <sub>CC</sub> or GND V <sub>OUT</sub> = GND	All	5.5 V	1		-0.6	μA
			B, S, Q, V		2		-11.0	
			All		1		-0.6	
			M		2, 3		-11.0	
			M		1		-3.0	
			D				-10.0	
			P, L, R				-20.0	
M, D, P, L, R, F	03		-5.0					
		Q, V						
Positive input clamp voltage 3022	V <sub>IC+</sub> <u>7/ 8/</u>	For input under test, I <sub>IN</sub> = 1 mA	All	GND	1	0.4	1.5	V
			B, S, Q, V		1	0.4	1.5	
			M			0.4	1.5	
			D			0.4	1.5	
		P, L, R						
Negative input clamp voltage 3022	V <sub>IC-</sub> <u>7/ 8/</u>	For input under test, I <sub>IN</sub> = -1 mA	All	OPEN	1	-0.4	-1.5	V
			B, S, Q, V		1	-0.4	-1.5	
			M			-0.4	-1.5	
			D			-0.4	-1.5	
		P, L, R						
Input current high 3010	I <sub>IH</sub> <u>7/ 8/</u> <u>10/</u>	For input under test, V <sub>IN</sub> = V <sub>CC</sub> For all other inputs, V <sub>IN</sub> = V <sub>CC</sub> or GND	All	5.5 V	1		0.1	μA
			B, S, Q, V		2		1.0	
			All		1		0.1	
			M		2, 3		1.0	
			M		1		0.1	
			D				0.1	
			P, L, R				0.1	

See footnotes at end of table.

**STANDARD  
MICROCIRCUIT DRAWING**  
DEFENSE SUPPLY CENTER COLUMBUS  
COLUMBUS, OHIO 43218-3990

SIZE  
**A**

REVISION LEVEL  
**F**

**5962-87663**

SHEET  
**8**



TABLE IA. Electrical performance characteristics - Continued.

Test and MIL-STD-883 test method <u>1/</u>	Symbol	Test Conditions <u>2/ 3/</u> -55°C ≤ T <sub>C</sub> ≤ +125°C +4.5 V ≤ V <sub>CC</sub> ≤ +5.5 V unless otherwise specified	Device type <u>4/</u> and device class	V <sub>CC</sub>	Group A subgroups	Limits <u>5/</u>		Unit
						Min	Max	
Input current low 3009	I <sub>IL</sub> <u>7/ 8/</u> <u>10/</u>	For input under test, V <sub>IN</sub> = GND For all other inputs, V <sub>IN</sub> = V <sub>CC</sub> or GND	All B, S, Q, V	5.5 V	1		-0.1	μA
					2		-1.0	
			All M		1		-0.1	
					2, 3		-1.0	
			M D		1		-0.1	
			P, L, R				-0.1	
Control input capacitance 3012	C <sub>IN</sub>	See 4.4.1c T <sub>C</sub> = +25°C	All All	GND	4		10.0	pF
Input/output capacitance 3012	C <sub>I/O</sub>	See 4.4.1c T <sub>C</sub> = +25°C	01, 03 All	5.5 V	4		15.0	pF
			02 All	5.0 V	4		24.0	
Power dissipation capacitance	C <sub>PD</sub> <u>11/</u>	See 4.4.1c T <sub>C</sub> = +25°C	01, 03 All	5.0 V	4		85.0	pF
			02 All	5.0 V	4		83.0	
Quiescent supply current delta, TTL input levels	ΔI <sub>CC</sub> <u>7/ 8/</u> <u>12/</u>	For input under test, V <sub>IN</sub> = V <sub>CC</sub> - 2.1 V For all other inputs, V <sub>IN</sub> = V <sub>CC</sub> or GND	01 B, S, Q, V	5.5 V	3		1.6	mA
					1, 2		1.0	
			03 Q, V		1, 2, 3		1.6	
			All M		1, 2, 3		1.6	
			M D		1		1.6	
			P, L, R				1.6	
Quiescent supply current, output high 3005	I <sub>CCH</sub> <u>7/ 8/</u>	OE = GND For all other inputs, V <sub>IN</sub> = V <sub>CC</sub> or GND	All B, S, Q, V	5.5 V	1		2.0	μA
					2		40.0	
			All M		1		8.0	
					2, 3		160.0	
			M D		1		300.0	
			P, L, R				1.0	
			3.0					
		M, D, P, L, R, F <u>13/</u>	03 Q, V			50	μA	

See footnotes at end of table.

**STANDARD  
MICROCIRCUIT DRAWING**  
DEFENSE SUPPLY CENTER COLUMBUS  
COLUMBUS, OHIO 43218-3990

SIZE  
**A**

REVISION LEVEL  
**F**

**5962-87663**

SHEET  
**9**

TABLE IA. Electrical performance characteristics - Continued.

Test and MIL-STD-883 test method <u>1/</u>	Symbol	Test Conditions <u>2/ 3/</u> -55°C ≤ T <sub>C</sub> ≤ +125°C +4.5 V ≤ V <sub>CC</sub> ≤ +5.5 V unless otherwise specified	Device type <u>4/</u> and device class	V <sub>CC</sub>	Group A subgroups	Limits <u>5/</u>		Unit	
						Min	Max		
Quiescent supply current, output low 3005	I <sub>CCL</sub> <u>7/ 8/</u>	OE = GND For all other inputs, V <sub>IN</sub> = V <sub>CC</sub> or GND	All	5.5 V	1		2.0	μA	
			B, S, Q, V		2		40.0		
			All		1		8.0		
			M		2, 3		160.0		
			M		01	1		300.0	mA
			D		B, S, Q, V			1.0	
			P, L, R					3.0	
M, D, P, L, R, F <u>13/</u>	03 Q, V			50	μA				
Quiescent supply current, outputs three-state 3005	I <sub>CCZ</sub> <u>7/ 8/</u>	OE = V <sub>CC</sub> For all other inputs, V <sub>IN</sub> = V <sub>CC</sub> or GND	All	5.5 V	1		2.0	μA	
			B, S, Q, V		2		40.0		
			All		1		8.0		
			M		2, 3		160.0		
			M		01	1		300.0	mA
			D		B, S, Q, V			1.0	
			P, L, R					3.0	
M, D, P, L, R, F <u>13/</u>	03 Q, V			50	μA				
Low level ground bounce noise	V <sub>GBL</sub> <u>14/ 15/</u>	V <sub>LD</sub> = 2.5 V I <sub>OL</sub> = +24 mA See figure 5	All B, S, Q, V	4.5 V	4		2000	mV	
High level ground bounce noise	V <sub>GBH</sub> <u>14/ 15/</u>	V <sub>LD</sub> = 2.5 V I <sub>OH</sub> = -24 mA See figure 5	All B, S, Q, V	4.5 V	4		2000	mV	
Latch-up input/output over-voltage	I <sub>CC</sub> (O/V1) <u>16/</u>	t <sub>w</sub> ≥ 100 μs, t <sub>cool</sub> ≥ t <sub>w</sub> 5 μs ≤ t <sub>r</sub> ≤ 5 ms 5 μs ≤ t <sub>f</sub> ≤ 5 ms V <sub>test</sub> = 6.0 V V <sub>CCQ</sub> = 5.5 V V <sub>over</sub> = 10.5 V	All B, S, Q, V	5.5 V	2		200	mA	
Latch-up input/output positive over-current	I <sub>CC</sub> (O/I1+) <u>16/</u>	t <sub>w</sub> ≥ 100 μs, t <sub>cool</sub> ≥ t <sub>w</sub> 5 μs ≤ t <sub>r</sub> ≤ 5 ms 5 μs ≤ t <sub>f</sub> ≤ 5 ms V <sub>test</sub> = 6.0 V V <sub>CCQ</sub> = 5.5 V I <sub>trigger</sub> = +120 mA	All B, S, Q, V	5.5 V	2		200	mA	
Latch-up input/output negative over-current	I <sub>CC</sub> (O/I1-) <u>16/</u>	t <sub>w</sub> ≥ 100 μs, t <sub>cool</sub> ≥ t <sub>w</sub> 5 μs ≤ t <sub>r</sub> ≤ 5 ms 5 μs ≤ t <sub>f</sub> ≤ 5 ms V <sub>test</sub> = 6.0 V V <sub>CCQ</sub> = 5.5 V I <sub>trigger</sub> = -120 mA	All B, S, Q, V	5.5 V	2		200	mA	

See footnotes at end of table.

<b>STANDARD MICROCIRCUIT DRAWING</b> DEFENSE SUPPLY CENTER COLUMBUS COLUMBUS, OHIO 43218-3990	SIZE <b>A</b>		<b>5962-87663</b>
		REVISION LEVEL <b>F</b>	SHEET 10

TABLE IA. Electrical performance characteristics - Continued.

Test and MIL-STD-883 test method <u>1/</u>	Symbol	Test Conditions <u>2/ 3/</u> -55°C ≤ T <sub>C</sub> ≤ +125°C +4.5 V ≤ V <sub>CC</sub> ≤ +5.5 V unless otherwise specified	Device type <u>4/</u> and device class	V <sub>CC</sub>	Group A subgroups	Limits <u>5/</u>		Unit				
						Min	Max					
Latch-up supply over-voltage	I <sub>CC</sub> (O/V2) <u>16/</u>	t <sub>w</sub> ≥ 100 μs, t <sub>cool</sub> ≥ t <sub>w</sub> 5 μs ≤ t <sub>r</sub> ≤ 5 ms 5 μs ≤ t <sub>f</sub> ≤ 5 ms V <sub>test</sub> = 6.0 V V <sub>CCQ</sub> = 5.5 V V <sub>over</sub> = 9.0 V	All B, S, Q, V	5.5 V	2		100	mA				
Truth table test output voltage 3014	<u>7/ 8/</u> <u>17/</u>	V <sub>IL</sub> = 0.40 V V <sub>IH</sub> = 2.40 V Verify output V <sub>OUT</sub> See 4.4.1	All	4.5 V	7, 8	L	H					
			All	5.5 V	7, 8	L	H					
			M	4.5 V	7	L	H					
			B, S, Q, V			L	H					
M	4.5 V	7	L	H								
P, L, R			L	H								
Propagation delay time, data to output, An to Bn and Bn to An 3003	t <sub>PHL</sub> , t <sub>PLH</sub> <u>7/ 8/</u> <u>18/ 19/</u>	C <sub>L</sub> = 50 pF minimum R <sub>L</sub> = 500Ω See figure 6	01	4.5 V	9, 11	1.0	8.0	ns				
			B, S, Q, V						10	1.0	10.0	
			02						9, 11	1.0	9.2	
			B, S, Q, V	10	1.0	10.6						
			03	4.5 V	9	1.0	8.5		ns			
			All							10, 11	1.0	10.0
			01							9	1.0	8.0
			M							10, 11	1.0	10.0
			02							9	1.0	9.2
			M							10, 11	1.0	10.6
			M	4.5 V	9	1.0	8.0					
			D							B, S, Q, V	1.0	8.0
P, L, R	1.0	8.0										
Propagation delay time, output enable, OE to An or Bn 3003	t <sub>PZH</sub> , t <sub>PZL</sub> <u>7/ 8/</u> <u>18/ 19/</u>	C <sub>L</sub> = 50 pF minimum R <sub>L</sub> = 500Ω See figure 6	01	4.5 V	9, 11	1.0	10.0	ns				
			B, S, Q, V						10	1.0	13.0	
			02						9, 11	1.0	12.0	
			B, S, Q, V	10	1.0	14.1						
			03	4.5 V	9	1.0	10.0		ns			
			All							10, 11	1.0	13.0
			01							9	1.0	10.0
			M							10, 11	1.0	13.0
			02							9	1.0	12.0
			M							10, 11	1.0	14.1
			M	4.5 V	9	1.0	10.0					
			D							B, S, Q, V	1.0	10.0
P, L, R	1.0	10.0										

See footnotes at end of table.

<b>STANDARD MICROCIRCUIT DRAWING</b> DEFENSE SUPPLY CENTER COLUMBUS COLUMBUS, OHIO 43218-3990	SIZE <b>A</b>		<b>5962-87663</b>
		REVISION LEVEL F	SHEET 11

TABLE IA. Electrical performance characteristics - Continued.

Test and MIL-STD-883 test method <u>1/</u>	Symbol	Test Conditions <u>2/ 3/</u> -55°C ≤ T <sub>C</sub> ≤ +125°C +4.5 V ≤ V <sub>CC</sub> ≤ +5.5 V unless otherwise specified	Device type <u>4/</u> and device class	V <sub>CC</sub>	Group A subgroups	Limits <u>5/</u>		Unit
						Min	Max	
Propagation delay time, output disable, OE to An or Bn 3003	t <sub>PHZ</sub> , t <sub>PLZ</sub> <u>7/ 8/</u> <u>18/ 19/</u>	C <sub>L</sub> = 50 pF minimum, R <sub>L</sub> = 500Ω, See figure 6	01	4.5 V	9, 11	1.0	10.0	ns
			B, S, Q, V		10	1.0	12.0	
			02		9, 10	1.0	12.9	
			B, S, Q, V	4.5 V	11	1.0	14.6	
			03		9	1.0	12.0	
			All		10, 11	1.0	13.0	
			01		9	1.0	10.0	
			M		10, 11	1.0	12.0	
			02		9	1.0	12.9	
			M	10, 11	1.0	14.6		
			M	01	9	1.0	10.0	
			D			1.0	10.0	
P, L, R	1.0	10.0						

1/ For tests not listed in the referenced MIL-STD-883 (e.g. ΔI<sub>CC</sub>), utilize the general test procedure under the conditions listed herein. All inputs and outputs shall be tested, as applicable, to the tests in table IA herein.

2/ Each input/output, as applicable, shall be tested at the specified temperature for the specified limits. Output terminals not designated shall be high level logic, low level logic, or open, except as follows:

- a. V<sub>IC</sub> (pos) tests, the GND terminal can be open. T<sub>C</sub> = +25°C.
- b. V<sub>IC</sub> (neg) tests, the V<sub>CC</sub> terminal shall be open. T<sub>C</sub> = +25°C.
- c. All I<sub>CC</sub> and ΔI<sub>CC</sub> tests, the output terminal shall be open. When performing these tests, the current meter shall be placed in the circuit such that all current flows through the meter.

3/ RHA parts for device type 01 of this drawing have been characterized through all levels M, D, P, L, and R of irradiation. However, these devices are only tested at the 'R' level. Pre and post irradiation values are identical unless otherwise specified in table IA. When performing post irradiation electrical measurements for any RHA level, T<sub>A</sub> = +25°C.

RHA parts for device type 03 of this drawing have been characterized through all levels M, D, P, L, R, and F of irradiation. However, these devices are only tested at the 'F' level. Pre and post irradiation values are identical unless otherwise specified in table IA. When performing post irradiation electrical measurements for any RHA level, T<sub>A</sub> = +25°C.

4/ The word "All" in the device type and device class column, means non-RHA limits for all device types and classes. M, D, P, L, R, and/or F in the conditions column are postirradiation limits for those device types and classes specified in the device type and device class column.

5/ For negative and positive voltage and current values, the sign designates the potential difference in reference to GND and the direction of current flow, respectively; and the absolute value of the magnitude, not the sign, is relative to the minimum and maximum limits, as applicable, listed herein.

<b>STANDARD MICROCIRCUIT DRAWING</b> DEFENSE SUPPLY CENTER COLUMBUS COLUMBUS, OHIO 43218-3990	SIZE <b>A</b>		<b>5962-87663</b>
		REVISION LEVEL <b>F</b>	SHEET 12

TABLE IA. Electrical performance characteristics - Continued.

- 6/ For device classes B, S, Q, and V, this test is guaranteed, if not tested, to the limits specified in table IA.
- 7/ RHA samples do not have to be tested at -55°C and +125°C prior to irradiation.
- 8/ When performing post irradiation electrical measurements for RHA level,  $T_A = +25^\circ\text{C}$ . Limits shown are guaranteed at  $T_A = +25^\circ\text{C} \pm 5^\circ\text{C}$ .
- 9/ Transmission driving tests are performed at  $V_{CC} = 5.5\text{ V}$  dc with a 2 ms duration maximum. This test may be performed using  $V_{IN} = V_{CC}$  or GND. When  $V_{IN} = V_{CC}$  or GND is used, the test is guaranteed for  $V_{IN} = 2.0\text{ V}$  or  $0.8\text{ V}$ .
- 10/ For  $I_{OZH}$  and  $I_{OZL}$  tests, three-state output conditions are required. For I/O pins, the  $I_{IH}$  and  $I_{IL}$  measurements shall not be directly performed. These measurements are included in the  $I_{OZH}$  and  $I_{OZL}$  limits, respectively.
- 11/ Power dissipation capacitance ( $C_{PD}$ ) determines the no load dynamic power consumption,  $P_D = (C_{PD} + C_L)(V_{CC} \times V_{CC})f + (I_{CC} \times V_{CC}) + (n \times d \times \Delta I_{CC} \times V_{CC})$  and the dynamic current consumption,  $I_S = (C_{PD} + C_L)V_{CC}f + I_{CC} + n \times d \times \Delta I_{CC}$ . For both  $P_D$  and  $I_S$ , n is the number of device inputs at TTL levels, f is the frequency of the input signal, and d is the duty cycle of the input signal.
- 12/ This test may be performed either one input at a time (preferred method) or with all input pins simultaneously at  $V_{IN} = V_{CC} - 2.1\text{ V}$  (alternate method). Classes B, S, Q, and V shall use the preferred method. When the test is performed using the alternate test method, the maximum limits are equal to the number of inputs at a high TTL input level times the  $\Delta I_{CC}$  maximum limits; and the preferred method and limits are guaranteed.
- 13/ The maximum limit for this parameter at 100 krad(s) is  $2.0\ \mu\text{A}$ .
- 14/ This test is for qualification only. Ground bounce tests are performed on a nonswitching (quiescent) output and are used to measure the magnitude of induced noise caused by other simultaneously switching outputs. The test is performed on a low noise bench test fixture with all outputs fully dc loaded ( $I_{OL}$  maximum and  $I_{OH}$  minimum =  $\pm 24\text{ mA}$ , for example) and  $50\text{ pF}$  load capacitance (see figure 5). The loads must be located as close as possible to the device output. Inputs are then conditioned with  $1\text{ MHz}$  pulse ( $t_r = t_f = 3.5 \pm 1.5\text{ ns}$ ) switching simultaneously and in phase such that one output is forced low and all others (possible) are switched. The low level ground bounce noise is measured at the quiet output using a F.E.T. oscilloscope probe with at least  $1\text{ M}\Omega$  impedance. Measurement is taken from the peak of the largest positive pulse with respect to the nominal low level output voltage (figure 5). The device inputs are then conditioned such that the output under test is at a high nominal  $V_{OH}$  level. The high level ground bounce measurement is then measured from nominal  $V_{OH}$  level to the largest negative peak. This procedure is repeated such that all outputs are tested at a high and low level with a maximum number of outputs switching.
- 15/ When used in synchronous TTL compatible systems, ground bounce ( $V_{GBL}$  and  $V_{GBH}$ ) =  $2,000\text{ mV}$  can be a possible problem.
- 16/ See EIA/JEDEC Standard No. 78 for electrically induced latch-up test methods and procedures. The values listed for  $I_{trigger}$  and  $V_{over}$  are to be accurate within  $\pm 5$  percent.
- 17/ Tests shall be performed in sequence, attributes data only. Functional tests shall include the truth table and other logic patterns used for fault detection. Functional tests shall be performed in sequence as approved by the qualifying activity on qualified devices. The input voltage levels have an allowable tolerance in accordance with MIL-STD-883 already incorporated. For outputs,  $L < 2.5\text{ V}$ ,  $H \geq 2.5\text{ V}$ . Functional tests at  $V_{CC} = 4.5\text{ V}$  are worst case for RHA specified devices.
- 18/ Device classes B, S, Q, and V are tested at  $V_{CC} = 4.5\text{ V}$  at  $T_C = +125^\circ\text{C}$  for sample testing and at  $V_{CC} = 4.5\text{ V}$  at  $T_C = +25^\circ\text{C}$  for screening. Other voltages of  $V_{CC}$  and temperatures are guaranteed, if not tested. See 4.4.1d.
- 19/ AC limits at  $V_{CC} = 5.5\text{ V}$  are equal to the limits at  $V_{CC} = 4.5\text{ V}$  and guaranteed by testing at  $V_{CC} = 4.5\text{ V}$ . Minimum ac limits for  $V_{CC} = 5.5\text{ V}$  are  $1.0\text{ ns}$  and guaranteed by guardbanding the  $V_{CC} = 4.5\text{ V}$  minimum limits to  $1.5\text{ ns}$ . For propagation delay tests, all paths must be tested.

<b>STANDARD MICROCIRCUIT DRAWING</b> DEFENSE SUPPLY CENTER COLUMBUS COLUMBUS, OHIO 43218-3990	SIZE <b>A</b>		<b>5962-87663</b>
		REVISION LEVEL F	SHEET 13

TABLE IB. SEP test limits. 1/ 2/

Device type	SEP	T <sub>C</sub> = temperature ±10°C	V <sub>CC</sub>	Effective LET
01	SEL	+25°C	4.5 V and 5.5 V	≥ 120 MeV-cm <sup>2</sup> /mg
03	SEL	+25°C	4.5 V and 5.5 V	≥ 93 MeV-cm <sup>2</sup> /mg

1/ For SEP test conditions, see 4.4.5.2 herein.

2/ Technology characterization and model verification supplemented by in-line data may be used in lieu of end-of-line testing. Test plan must be approved by TRB and qualifying activity.

**STANDARD  
MICROCIRCUIT DRAWING**  
DEFENSE SUPPLY CENTER COLUMBUS  
COLUMBUS, OHIO 43218-3990

SIZE  
**A**

REVISION LEVEL  
F

**5962-87663**

SHEET  
14

Case X

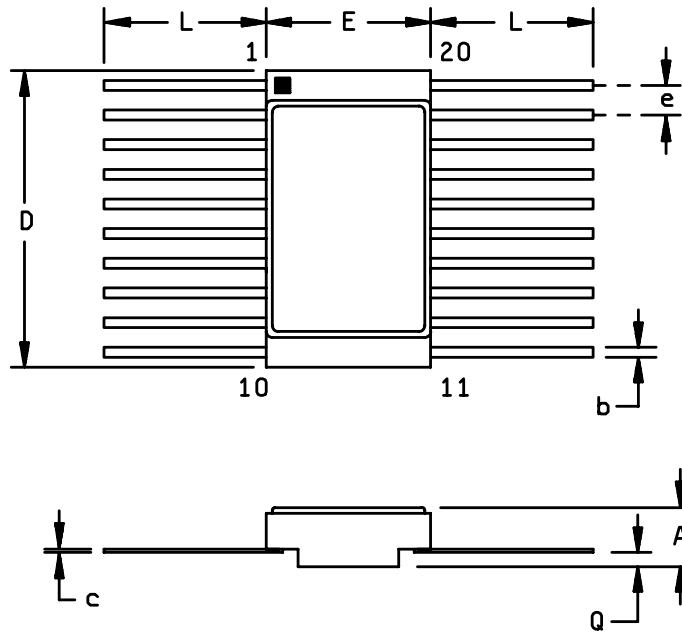

Symbol	Dimensions			
	Inches		Millimeters	
	Min	Max	Min	Max
A	.045	.085	1.14	2.16
b	.015	.019	0.38	0.48
c	.003	.006	0.076	0.152
D	.505	.515	12.83	13.08
E	.275	.285	6.99	7.24
e	.045	.055	1.14	1.40
L	.250	.370	6.35	9.39
Q	.010	---	0.25	---
N	20		20	

FIGURE 1. Case outlines.

**STANDARD  
MICROCIRCUIT DRAWING**  
DEFENSE SUPPLY CENTER COLUMBUS  
COLUMBUS, OHIO 43218-3990

SIZE  
**A**

REVISION LEVEL  
F

**5962-87663**

SHEET  
15

Device types	01, 03	02	
Case outlines	R, S, X, and 2	L	3
Terminal number	Terminal symbol		
1	$\overline{T/R}$	A0	NC
2	A0	A1	$V_{CC}$
3	A1	A2	B3
4	A2	A3	B2
5	A3	GND	B1
6	A4	GND	$\overline{B0}$
7	A5	GND	$\overline{T/R}$
8	A6	GND	NC
9	A7	A4	A0
10	GND	A5	A1
11	B7	A6	A2
12	B6	$\overline{A7}$	A3
13	B5	$\overline{OE}$	GND
14	B4	B7	GND
15	B3	B6	NC
16	B2	B5	GND
17	B1	B4	GND
18	$\overline{B0}$	$V_{CC}$	A4
19	$\overline{OE}$	$V_{CC}$	A5
20	$V_{CC}$	B3	A6
21	---	B2	A7
22	---	B1	$\overline{NC}$
23	---	$\overline{B0}$	$\overline{OE}$
24	---	$\overline{T/R}$	B7
25	---	---	B6
26	---	---	B5
27	---	---	B4
28	---	---	$V_{CC}$

NC = No connection

FIGURE 2. Terminal connections.

All device types		
Inputs		Output
$\overline{OE}$	$\overline{T/R}$	
L	L	Bus B data to Bus A
L	H	Bus A data to Bus B
H	X	High Z state

H = High voltage level  
L = Low voltage level  
X = Irrelevant  
Z = High impedance

NOTE: When  $\overline{OE} = H$ , all inputs and outputs are in the Z state.

FIGURE 3. Truth table.

<b>STANDARD  MICROCIRCUIT DRAWING</b> DEFENSE SUPPLY CENTER COLUMBUS COLUMBUS, OHIO 43218-3990	SIZE <b>A</b>		<b>5962-87663</b>
		REVISION LEVEL <b>F</b>	SHEET 16



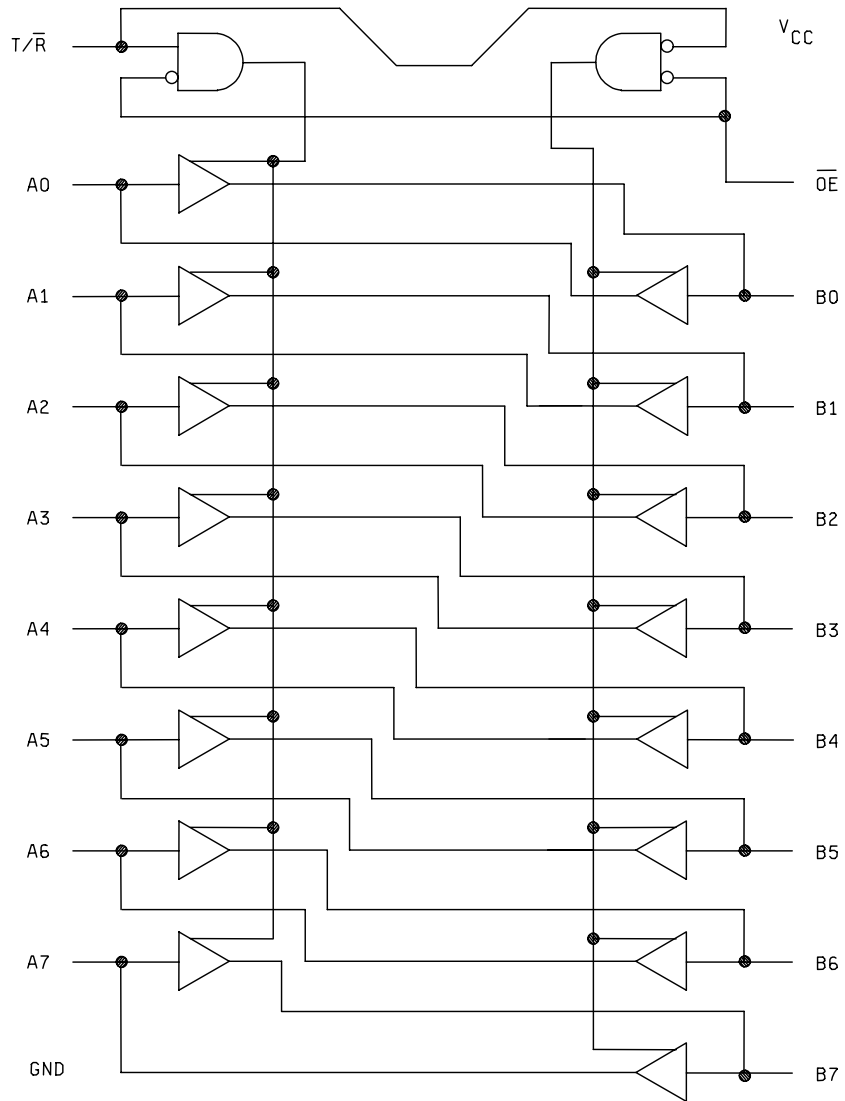

FIGURE 4. Logic diagram.

**STANDARD  
MICROCIRCUIT DRAWING**  
DEFENSE SUPPLY CENTER COLUMBUS  
COLUMBUS, OHIO 43218-3990

SIZE  
**A**

REVISION LEVEL  
**F**

**5962-87663**

SHEET  
17

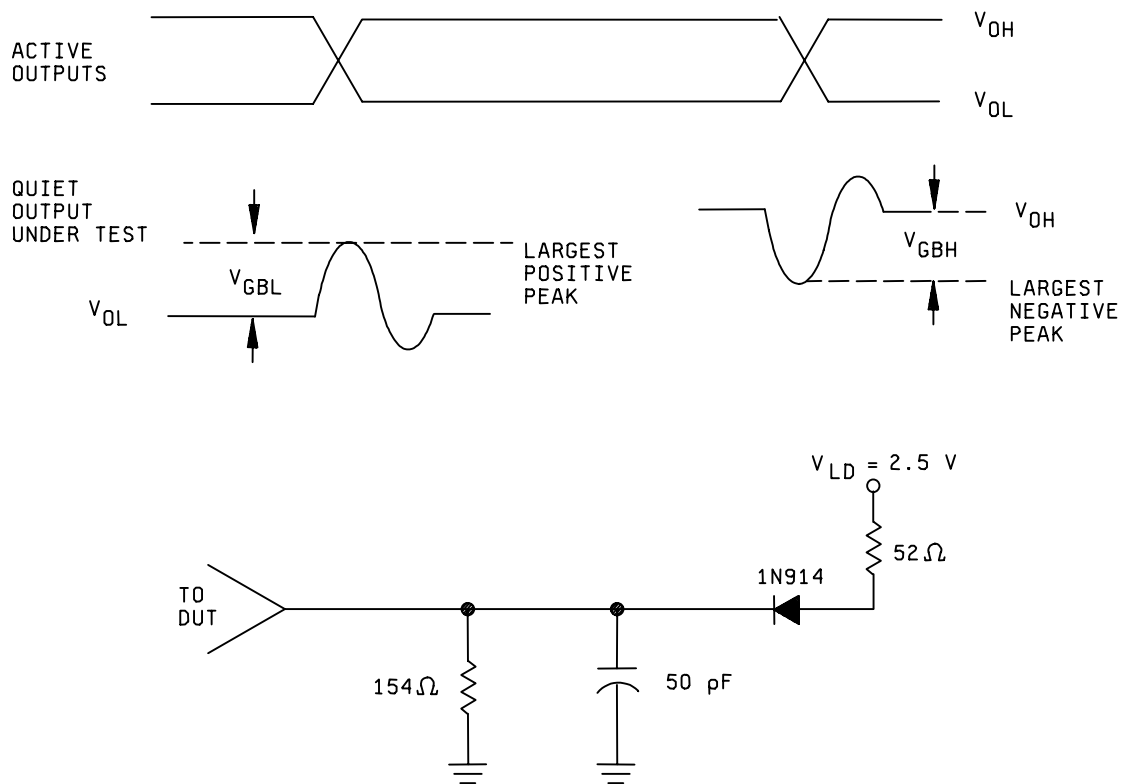

NOTE: Resistor and capacitor tolerances =  $\pm 10\%$ .

FIGURE 5. Ground bounce waveforms and test circuit.

<b>STANDARD MICROCIRCUIT DRAWING</b> DEFENSE SUPPLY CENTER COLUMBUS COLUMBUS, OHIO 43218-3990	SIZE <b>A</b>		<b>5962-87663</b>
		REVISION LEVEL <b>F</b>	SHEET 18

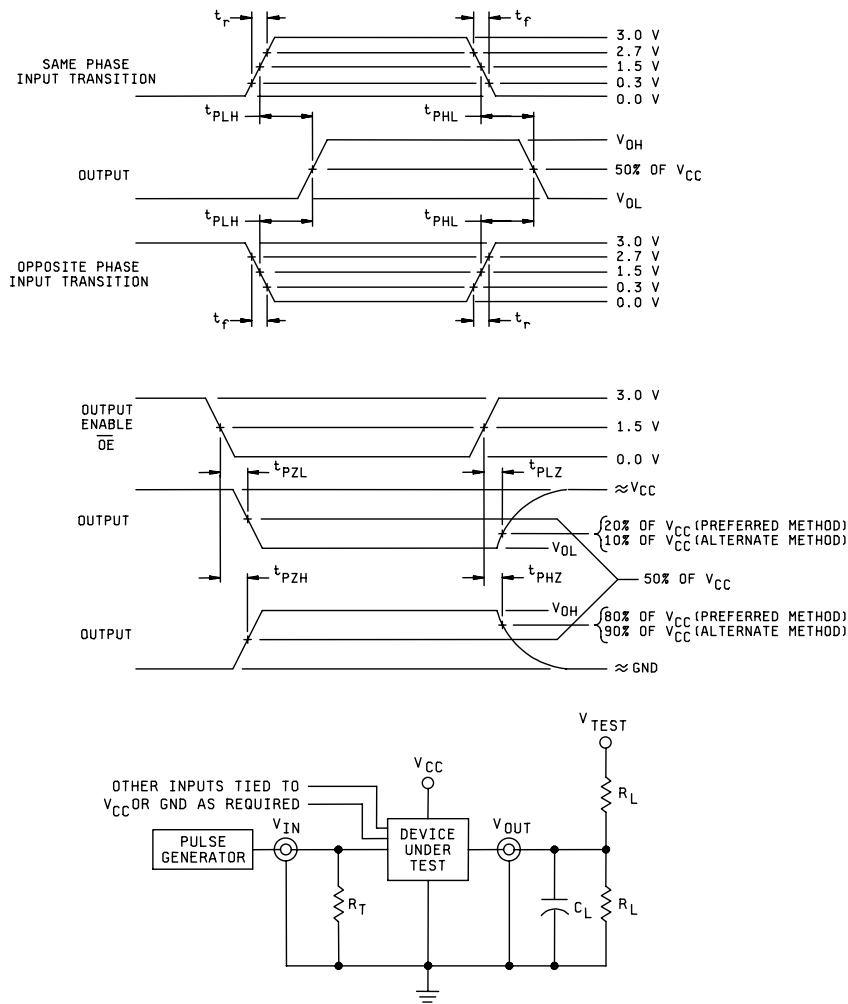

**NOTES:**

1. Preferred method - used for device type 02:  
 When measuring  $t_{PHZ}$  and  $t_{PZH}$ :  $V_{TEST} = GND$   
 When measuring  $t_{PLZ}$  and  $t_{PZL}$ :  $V_{TEST} = 2 \times V_{CC}$   
 When measuring  $t_{PLH}$  and  $t_{PHL}$ :  $V_{TEST} = \text{open}$   
 Alternate method - used for device types 01 and 03:  
 When measuring  $t_{PLZ}$  and  $t_{PZL}$ :  $V_{TEST} = 2 \times V_{CC}$   
 When measuring  $t_{PHZ}$ ,  $t_{PZH}$ ,  $t_{PLH}$ , and  $t_{PHL}$ :  $V_{TEST} = \text{open}$
2.  $C_L = 50 \text{ pF}$  minimum or equivalent (includes test jig and probe capacitance).
3.  $R_T = 50\Omega$  or equivalent.  $R_L = 500\Omega$  or equivalent.
4. Input signal from pulse generator:  $V_{IN} = 0.0 \text{ V}$  to  $3.0 \text{ V}$ ;  $PRR \leq 10 \text{ MHz}$ ;  $t_r \leq 3 \text{ ns}$ ;  $t_f \leq 3 \text{ ns}$ ; duty cycle = 50 percent.
5. Timing parameters shall be tested at a minimum input frequency of 1 MHz.
6. Outputs are measured one at a time with one output per measurement.

FIGURE 6. Switching waveforms and test circuit.

<b>STANDARD MICROCIRCUIT DRAWING</b> DEFENSE SUPPLY CENTER COLUMBUS COLUMBUS, OHIO 43218-3990	SIZE <b>A</b>		<b>5962-87663</b>
		REVISION LEVEL <b>F</b>	SHEET 19

4. VERIFICATION

4.1 Sampling and inspection. For device classes B, S, Q, and V, sampling and inspection procedures shall be in accordance with MIL-PRF-38535 or as modified in the device manufacturer's Quality Management (QM) plan. The modification in the QM plan shall not affect the form, fit, or function as described herein. For device class M, sampling and inspection procedures shall be in accordance with MIL-PRF-38535, appendix A

4.2 Screening. For device classes B, S, Q, and V, screening shall be in accordance with MIL-PRF-38535, and shall be conducted on all devices prior to qualification and technology conformance inspection. For device class M, screening shall be in accordance with method 5004 of MIL-STD-883, and shall be conducted on all devices prior to quality conformance inspection.

4.2.1 Additional criteria for device classes M, B, and S.

a. Burn-in test, method 1015 of MIL-STD-883.

- (1) Test condition A, B, C, or D. The test circuit shall be maintained by the manufacturer under document revision level control and shall be made available to the preparing or acquiring activity upon request. The test circuit shall specify the inputs, outputs, biases, and power dissipation, as applicable, in accordance with the intent specified in method 1015 of MIL-STD-883.
- (2)  $T_A = +125^\circ\text{C}$ , minimum.
- (3) Delete the sequence specified in 3.1.10 through 3.1.14 of method 5004 and substitute lines 1 through 7 test requirements of table IIA herein.
- (4) For device class M, unless otherwise specified, the requirements for device class B in method 1015 of MIL-STD-883 shall be followed.
- (5) Unless otherwise specified in the QM plan for static burn-in, device class B and S, test condition A, method 1015 of MIL-STD-883, test duration for each static test shall be 24 hours minimum for class S devices and in accordance with table IA of method 1015 for class B devices.
  - (a) For static burn-in I, all inputs shall be connected to GND. Outputs may be open or connected to  $V_{CC}/2 \pm 0.5\text{ V}$ . Resistors R1 are optional on both inputs and open outputs, and required on outputs connected to  $V_{CC}/2 \pm 0.5\text{ V}$ .  $R1 = 220\Omega$  to  $47\text{ k}\Omega$ .
  - (b) For static burn-in II, all inputs shall be connected through the R1 resistors to  $V_{CC}$ . Outputs may be open or connected to  $V_{CC}/2 \pm 0.5\text{ V}$ . Resistors R1 are optional in open outputs and required on outputs connected to  $V_{CC}/2 \pm 0.5\text{ V}$ .  $R1 = 220\Omega$  to  $47\text{ k}\Omega$ .
  - (c)  $V_{CC} = 5.5\text{ V} +0.5\text{ V}, -0.00\text{ V}$ .
- (6) Unless otherwise specified in the QM plan for dynamic burn-in, device classes B and S, test condition D, method 1015 of MIL-STD-883, the following shall apply:
  - (a) Input resistors =  $220\Omega$  to  $2\text{ k}\Omega \pm 20$  percent.
  - (b) Output resistors =  $220\Omega \pm 20$  percent.
  - (c)  $V_{CC} = 5.5\text{ V} +0.5\text{ V}, -0.00\text{ V}$ .

<b>STANDARD MICROCIRCUIT DRAWING</b> DEFENSE SUPPLY CENTER COLUMBUS COLUMBUS, OHIO 43218-3990	SIZE <b>A</b>		<b>5962-87663</b>
		REVISION LEVEL F	SHEET 20

- (d) The output enable control pin(s) shall be connected through the resistors in parallel to  $V_{CC}$  or GND, as applicable, to enable the outputs. All other inputs shall be connected through the resistors in parallel to a common clock pulse (CP), as applicable. Outputs shall be connected through the resistors to  $V_{CC}/2 \pm 0.5 V$ .
- (e) CP = 25 kHz to 1 MHz square wave; duty cycle = 50 percent  $\pm 15$  percent;  $V_{IH} = 4.5 V$  to  $V_{CC}$ ,  $V_{IL} = 0 V \pm 0.5 V$ ;  $t_r, t_f \leq 100 ns$ .
- b. Interim and final electrical test parameters shall be as specified in table IIA herein.
- c. For class S devices, post dynamic burn-in, or class B devices, post static burn-in, electrical parameter measurements may, at the manufacturer's option, be performed separately or included in the final electrical parameter requirements.

TABLE IIA. Electrical test requirements.

Test requirements	Subgroups <u>1/</u> (in accordance with MIL-STD-883, method 5005, table I)	Subgroups <u>1/</u> (in accordance with MIL-PRF-38535, table III)			
	Device class M	Device <u>2/</u> class B	Device <u>2/</u> class S	Device class Q	Device class V
Interim electrical parameters, method 5004		1	1	1	1
Static burn-in I, method 1015 (4.2.1a)	<u>3/</u>	Not required	Required <u>4/</u>	Not required	Required <u>4/</u>
Interim electrical parameters, method 5004 (4.2.1b)			1 <u>5/</u>		1 <u>5/</u>
Static burn-in II, method 1015 (4.2.1a)	<u>3/</u>	Required <u>6/</u>	Required <u>4/</u>	Required <u>6/</u>	Required <u>4/</u>
Interim electrical parameters, method 5004 (see 4.2.1b)		1 <u>2/</u> , <u>5/</u>	1 <u>2/</u> , <u>5/</u>	1 <u>2/</u> , <u>5/</u>	1 <u>2/</u> , <u>5/</u>
Dynamic burn-in I, method 1015 (4.2.1a)	<u>3/</u>	Not required	Required <u>4/</u>	Not required	Required <u>4/</u>
Interim electrical parameters, method 5004 (4.2.1b)			1 <u>5/</u>		1 <u>5/</u>
Final electrical parameters, method 5004	1, 2, 3, 7, 8, 9 <u>2/</u>	1, 2, 7, 9 <u>2/</u> , <u>6/</u>	1, 2, 7, 9 <u>2/</u>	1, 2, 3, 7, 8, 9, 10, 11 <u>2/</u> , <u>6/</u>	1, 2, 3, 7, 8, 9, 10, 11 <u>2/</u>
Group A test requirements, method 5005 (4.4.1)	1, 2, 3, 4, 7, 8, 9, 10, 11	1, 2, 3, 4, 7, 8, 9, 10, 11	1, 2, 3, 4, 7, 8, 9, 10, 11	1, 2, 3, 4, 7, 8, 9, 10, 11	1, 2, 3, 4, 7, 8, 9, 10, 11
Group B end-point electrical parameters, method 5005 (4.4.2)			1, 2, 3, 7, 8, 9, 10, 11 <u>5/</u>		
Group C end-point electrical parameters, method 5005 (4.4.3)	1, 2, 3	1, 2 <u>5/</u>		1, 2, 3 <u>5/</u>	1, 2, 3, 7, 8, 9, 10, 11 <u>5/</u>
Group D end-point electrical parameters, method 5005 (4.4.4)	1, 2, 3	1, 2	1, 2, 3	1, 2, 3	1, 2, 3
Group E end-point electrical parameters, method 5005 (4.4.5)	1, 7, 9	1, 7, 9	1, 7, 9	1, 7, 9	1, 7, 9

See footnotes on next sheet.

<b>STANDARD MICROCIRCUIT DRAWING</b> DEFENSE SUPPLY CENTER COLUMBUS COLUMBUS, OHIO 43218-3990	SIZE <b>A</b>		<b>5962-87663</b>
		REVISION LEVEL <b>F</b>	SHEET 21

TABLE IIA. Electrical test requirements – Continued.

- 1/ Blank spaces indicate tests are not applicable.
- 2/ PDA applies to subgroup 1 (see 4.2.3). For device classes S and V, PDA applies to subgroups 1 and 7 (see 4.2.3).
- 3/ The burn-in shall meet the requirements of 4.2.1a herein.
- 4/ On all class S lots, the device manufacturer shall maintain read-and-record data (as a minimum on disk) for burn-in electrical parameters (group A, subgroup 1), in accordance with method 5004 of MIL-STD-883. For pre-burn-in and interim electrical parameters, the read-and-record requirements are for delta measurements only.
- 5/ Delta limits shall be required only on table IA, subgroup 1. The delta values shall be computed with reference to the previous interim electrical parameters. The delta limits are specified in table IIB.
- 6/ The device manufacturer may at his option either complete subgroup 1 electrical parameter measurements, including delta measurements, within 96 hours after burn-in completion (removal of bias); or may complete subgroup 1 electrical measurements without delta measurements within 24 hours after burn-in completion (removal of bias). When the manufacturer elects to perform the subgroup 1 electrical parameter measurements without delta measurements, there is no requirement to perform the pre-burn-in electrical tests (first interim electrical parameters test in table IIA).

4.2.2 Additional criteria for device classes B, S, Q, and V.

- a. The burn-in test duration, test condition and test temperature, or approved alternatives shall be as specified in the device manufacturer's QM plan in accordance with MIL-PRF-38535. The burn-in test circuit shall be maintained under document revision level control of the device manufacturer's Technology Review Board (TRB) in accordance with MIL-PRF-38535 and shall be made available to the acquiring or preparing activity upon request. The test circuit shall specify the inputs, outputs, biases, and power dissipation, as applicable, in accordance with the intent specified in method 1015 of MIL-STD-883.
- b. Interim and final electrical test parameters shall be as specified in table IIA herein.
- c. Additional screening for device class V or S beyond the requirements of device class Q or B shall be as specified in MIL-PRF-38535, appendix B.

4.2.3 Percent defective allowable (PDA).

- a. The PDA for class S or V devices shall be 5 percent for static burn-in and 5 percent for dynamic burn-in, based on the exact number of devices submitted to each separate burn-in.
- b. Static burn-in I and II failures shall be cumulative for determining the PDA.
- c. The PDA for class B or Q devices shall be in accordance with MIL-PRF-38535 for static burn-in. Dynamic burn-in is not required.
- d. The PDA for class M devices shall be in accordance with MIL-PRF-38535, appendix A for static burn-in and dynamic burn-in.
- e. Those devices whose measured characteristics, after burn-in, exceed the specified delta limits or electrical parameter limits specified in table I, subgroup I, are defective and shall be removed from the lot. The verified number of failed devices times 100 divided by the total number of devices in the lot initially submitted to burn-in shall be used to determine the percent defective for the lot, and the lot shall be accepted or rejected based on the specified PDA.

4.3 Qualification inspection for device classes B, S, Q, and V. Qualification inspection for device classes B, S, Q, and V shall be in accordance with MIL-PRF-38535. Inspections to be performed shall be those specified in MIL-PRF-38535 and herein for groups A, B, C, D, and E inspections (see 4.4.1 through 4.4.5).

<b>STANDARD MICROCIRCUIT DRAWING</b> DEFENSE SUPPLY CENTER COLUMBUS COLUMBUS, OHIO 43218-3990	SIZE <b>A</b>		<b>5962-87663</b>
		REVISION LEVEL <b>F</b>	SHEET 22

TABLE IIB. Burn-in and operating life test, delta parameters (+25°C).

Parameter <sup>1/</sup>	Symbol	Device types	Delta limits
Supply current	$I_{CCH}, I_{CCL}, I_{CCZ}$	01 <sup>2/</sup>	±100 nA
		03	±300 nA
Supply current delta	$\Delta I_{CC}$	03	±0.4 mA
Input current low level	$I_{IL}$	03	±20 nA
Input current high level	$I_{IH}$	03	±20 nA
Output voltage low level $V_{CC} = 5.5 \text{ V } I_{OL} = 24 \text{ mA}$	$V_{OL}$	03	±0.04 V
Output voltage high level $V_{CC} = 5.5 \text{ V } I_{OH} = -24 \text{ mA}$	$V_{OH}$	03	±0.20 V

- <sup>1/</sup> These parameters shall be recorded before and after the required burn-in and life tests to determine delta limits.  
<sup>2/</sup> This parameter is not production tested.

4.4 Conformance inspection. Technology conformance inspection for classes B, S, Q, and V shall be in accordance with MIL-PRF-38535 including groups A, B, C, D, and E inspections and as specified herein. Quality conformance inspection for device class M shall be in accordance with MIL-PRF-38535, appendix A and as specified herein. Inspections to be performed for device class M shall be those specified in method 5005 of MIL-STD-883 and herein for groups A, B, C, D, and E inspections (see 4.4.1 through 4.4.5).

4.4.1 Group A inspection.

- a. Tests shall be as specified in table IIA herein.
- b. Latch-up and ground bounce tests are required for device classes B, S, Q, and V. These tests shall be performed only for initial qualification and after process or design changes which may affect the performance of the device. Latch-up tests shall be considered destructive. For latch-up and ground bounce tests, test all applicable pins on five devices with zero failures.
- c.  $C_{IN}$ ,  $C_{I/O}$ , and  $C_{PD}$  shall be measured only for initial qualification and after process or design changes which may affect capacitance.  $C_{IN}$  and  $C_{I/O}$  shall be measured between the designated terminal and GND at a frequency of 1 MHz.  $C_{PD}$  shall be tested in accordance with the latest revision of JEDEC Standard No. 20 and table IA herein. For  $C_{IN}$ ,  $C_{I/O}$ , and  $C_{PD}$ , test all applicable pins on five devices with zero failures.
- d. For device classes B, S, Q, and V, subgroups 9 and 11 tests shall be measured only for initial qualification and after process or design changes which may affect dynamic performance.
- e. For device class M, subgroups 7 and 8 tests shall be sufficient to verify the truth table in figure 3 herein. The test vectors used to verify the truth table shall test all possible input to output logic patterns. For device classes B, S, Q and V, subgroups 7 and 8 shall include verifying the functionality of the device.

4.4.2 Group B inspection. When applicable, the group B inspection end-point electrical parameters shall be as specified in table IIA herein. For device class S steady-state life tests, the test circuit shall be maintained by the manufacturer and made available to the acquiring or preparing activity upon request.

4.4.3 Group C inspection. The group C inspection end-point electrical parameters shall be as specified in table IIA herein.

<b>STANDARD MICROCIRCUIT DRAWING</b> DEFENSE SUPPLY CENTER COLUMBUS COLUMBUS, OHIO 43218-3990	SIZE <b>A</b>		<b>5962-87663</b>
		REVISION LEVEL <b>F</b>	SHEET 23

4.4.3.1 Additional criteria for device class M. Steady-state life test conditions, method 1005 of MIL-STD-883:

- a. Test condition A, B, C, or D. The test circuit shall be maintained by the manufacturer under document revision level control and shall be made available to the preparing or acquiring activity upon request. The test circuit shall specify the inputs, outputs, biases, and power dissipation, as applicable, in accordance with the intent specified in method 1005 of MIL-STD-883.
- b.  $T_A = +125^\circ\text{C}$ , minimum.
- c. Test duration: 1,000 hours, except as permitted by method 1005 of MIL-STD-883.

4.4.3.2 Additional criteria for device classes B, S, Q, and V. The steady-state life test duration, test condition and test temperature, or approved alternatives shall be as specified in the device manufacturer's QM plan in accordance with MIL-PRF-38535. The test circuit shall be maintained under document revision level control by the device manufacturer's TRB in accordance with MIL-PRF-38535 and shall be made available to the acquiring or preparing activity upon request. The test circuit shall specify the inputs, outputs, biases, and power dissipation, as applicable, in accordance with the intent specified in method 1005 of MIL-STD-883.

4.4.4 Group D inspection. Group D inspection end-point electrical parameters shall be as specified in table IIA herein.

4.4.5 Group E inspection. Group E inspection is required only for parts intended to be marked as radiation hardness assured (see 3.5 herein).

- a. End-point electrical parameters shall be as specified in table IIA herein.
- b. For device classes B, S, Q, and V, the devices or test vehicle shall be subjected to radiation hardness assured tests as specified in MIL-PRF-38535 for RHA level being tested. For device class M, the devices shall be subjected to radiation hardness assured tests as specified in MIL-PRF-38535, appendix A for RHA level being tested. All device classes must meet the postirradiation end-point electrical parameter limits as defined in table IA at  $T_A = +25^\circ\text{C} \pm 5^\circ$ , after exposure, to the subgroups specified in table IIA herein.
- c. RHA tests for device classes M, B, S, Q, and V for levels M, D, P, L, R, and F shall be performed through each level to determine at what levels the devices meet the RHA requirements. These RHA tests shall be performed for initial qualification and after design or process changes which may affect the RHA performance of the device.
- d. Prior to irradiation, each selected sample shall be assembled in its qualified package. It shall pass the specified group A electrical parameters in table IA for subgroups specified in table IIA herein.

4.4.5.1 Total dose irradiation testing. Total dose irradiation testing shall be performed in accordance with MIL-STD-883, method 1019, condition A and as specified herein. Prior to and during total dose irradiation characterization and testing, the devices for characterization shall be biased so that 50 percent are at inputs high and 50 percent are at inputs low, and the devices for testing shall be biased to the worst case condition established during characterization. Devices shall be biased as follows:

a. Device type 01:

(1) Inputs tested high,  $V_{CC} = 5.5 \text{ V dc } +5\%$ ,  $R_{CC} = 10\Omega \pm 20\%$ ,  $V_{IN} = 5.0 \text{ V dc } +5\%$ ,  $R_{IN} = 1 \text{ k}\Omega \pm 20\%$  and all outputs are open.

(2) Inputs tested low,  $V_{CC} = 5.5 \text{ V dc } +5\%$ ,  $R_{CC} = 10\Omega \pm 20\%$ ,  $V_{IN} = 0.0 \text{ V dc}$ ,  $R_{IN} = 1 \text{ k}\Omega \pm 20\%$  and all outputs are open.

b. Device type 03:

(1) Inputs tested high,  $V_{CC} = 5.5 \text{ V dc } \pm 5\%$ ,  $V_{IN} = 5.0 \text{ V dc } +10\%$ ,  $R_{IN} = 1 \text{ k}\Omega \pm 20\%$ , and all outputs are open.

(2) Inputs tested low,  $V_{CC} = 5.5 \text{ V dc } \pm 5\%$ ,  $V_{IN} = 0.0 \text{ V dc}$ ,  $R_{IN} = 1 \text{ k}\Omega \pm 20\%$ , and all outputs are open.

<b>STANDARD MICROCIRCUIT DRAWING</b> DEFENSE SUPPLY CENTER COLUMBUS COLUMBUS, OHIO 43218-3990	SIZE <b>A</b>		<b>5962-87663</b>
		REVISION LEVEL <b>F</b>	SHEET 24



4.4.5.1.1 Accelerated annealing test. Accelerated annealing tests shall be performed on all devices requiring an RHA level greater than 5K rads (Si). The post-anneal end-point electrical parameter limits shall be as specified in table IA herein and shall be the pre-irradiation end-point electrical parameter limit at +25°C ±5°C. Testing shall be performed at initial qualification and after any design or process changes which may affect the RHA response of the device.

4.4.5.2 Single event phenomena (SEP). When specified in the purchase order or contract, SEP testing shall be required on class V devices. SEP testing shall be performed on the Standard Evaluation Circuit (SEC) or alternate SEP test vehicle as approved by the qualifying activity at initial qualification and after any design or process changes which may affect the upset or latchup characteristics. Test four devices with zero failures. ASTM F1192 may be used as a guideline when performing SEP testing. The test conditions for SEP are as follows:

- a. The ion beam angle of incidence shall be between normal to the die surface and 60° to the normal, inclusive (i.e. 0° ≤ angle ≤ 60°). No shadowing of the ion beam due to fixturing or package related effects is allowed.
- b. The fluence shall be ≥ 100 errors or ≥ 10<sup>7</sup> ions/cm<sup>2</sup>.
- c. The flux shall be between 10<sup>2</sup> and 10<sup>5</sup> ions/cm<sup>2</sup>/s. The cross-section shall be verified to be flux independent by measuring the cross-section at two flux rates which differ by at least an order of magnitude.
- d. The particle range shall be ≥ 20 microns in silicon.
- e. The upset test temperature shall be +25°C and the latchup test temperature is maximum rated operating temperature ±10°C.
- f. Bias conditions shall be defined by the manufacturer for latchup measurements.
- g. For SEP test limits, see table IB herein.

4.5 Methods of inspection. Methods of inspection shall be specified as follows:

4.5.1 Voltage and current. Unless otherwise specified, all voltages given are referenced to the microcircuit GND terminal. Currents given are conventional current and positive when flowing into the referenced terminal.

5. PACKAGING

5.1 Packaging requirements. The requirements for packaging shall be in accordance with MIL-PRF-38535 for device classes B, S, Q, and V or MIL-PRF-38535, appendix A for device class M.

6. NOTES

6.1 Intended use. Microcircuits conforming to this drawing are intended for use for Government microcircuit applications (original equipment), design applications, and logistics purposes.

6.1.1 Replaceability. Microcircuits covered by this drawing will replace the same generic device covered by a contractor-prepared specification or drawing.

6.1.2 Substitutability. Device classes B and Q devices will replace device class M devices.

6.1.2.1 Substitution data.

<u>New PIN</u>	<u>Old PIN</u>
5962-8766301MRA	5962-8766301RA
5962-8766301MSA	5962-8766301SA
5962-8766301M2A	5962-87663012A

<b>STANDARD MICROCIRCUIT DRAWING</b> DEFENSE SUPPLY CENTER COLUMBUS COLUMBUS, OHIO 43218-3990	SIZE <b>A</b>		<b>5962-87663</b>
		REVISION LEVEL F	SHEET 25

6.2 Configuration control of SMD's. All proposed changes to existing SMD's will be coordinated with the users of record for the individual documents. This coordination will be accomplished using DD Form 1692, Engineering Change Proposal.

6.3 Record of users. Military and industrial users should inform Defense Supply Center Columbus (DSCC) when a system application requires configuration control and which SMD's are applicable to that system. DSCC will maintain a record of users and this list will be used for coordination and distribution of changes to the drawings. Users of drawings covering microelectronic devices (FSC 5962) should contact DSCC-VA, telephone (614) 692-0544.

6.4 Comments. Comments on this drawing should be directed to DSCC-VA, Columbus, Ohio 43218-3990, or telephone (614) 692-0547.

6.5 Abbreviations, symbols, and definitions. The abbreviations, symbols, and definitions used herein are defined in MIL-PRF-38535 and MIL-HDBK-1331.

6.6 Sources of supply.

6.6.1 Sources of supply for device classes B, S, Q, and V. Sources of supply for device classes B, S, Q, and V are listed in QML-38535. The vendors listed in QML-38535 have submitted a certificate of compliance (see 3.6 herein) to DSCC-VA and have agreed to this drawing.

6.6.2 Approved sources of supply for device class M. Approved sources of supply for class M are listed in MIL-HDBK-103. The vendors listed in MIL-HDBK-103 have agreed to this drawing and a certificate of compliance (see 3.6 herein) has been submitted to and accepted by DSCC-VA.

6.7 Additional information. When specified in the purchase order or contract, a copy of the following additional data shall be supplied.

- a. RHA upset levels.
- b. Test conditions (SEP).
- c. Number of upsets (SEP).
- d. Number of transients (SEP).
- e. Occurrence of latchup (SEP).

<b>STANDARD MICROCIRCUIT DRAWING</b> DEFENSE SUPPLY CENTER COLUMBUS COLUMBUS, OHIO 43218-3990	SIZE <b>A</b>		<b>5962-87663</b>
		REVISION LEVEL F	SHEET 26

APPENDIX A  
APPENDIX A FORMS A PART OF SMD 5962-87663

A.1 SCOPE

A.1.1 Scope. This appendix establishes minimum requirements for microcircuit die to be supplied under the Qualified Manufacturers List (QML) Program. QML microcircuit die meeting the requirements of MIL-PRF-38535 and the manufacturers approved QM plan for use in monolithic microcircuits, multi-chip modules (MCMs), hybrids, electronic modules, or devices using chip and wire designs in accordance with MIL-PRF-38534 are specified herein. Two product assurance classes consisting of military high reliability (device class Q) and space application (device class V) are reflected in the Part or Identification Number (PIN). When available, a choice of Radiation Hardness Assurance (RHA) levels are reflected in the PIN.

A.1.2 PIN. The PIN is as shown in the following example:

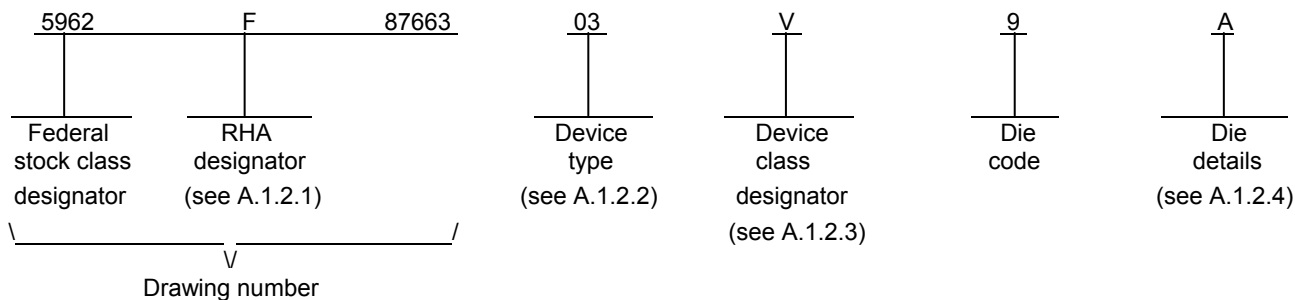

A.1.2.1 RHA designator. Device classes Q and V RHA identified die meet the MIL-PRF-38535 specified RHA levels. A dash (-) indicates a non-RHA die.

A.1.2.2 Device type(s). The device type(s) identify the circuit function as follows:

<u>Device type</u>	<u>Generic number</u>	<u>Circuit function</u>
03	54ACT245	Octal transceiver with three-state outputs, TTL compatible inputs

A.1.2.3 Device class designator. Device class Q designator will not be included in the PIN and will not be marked on the device since the device class designator has been added after the original issuance of this drawing.

<u>Device class</u>	<u>Device requirements documentation</u>
Q or V	Certification and qualification to the die requirements of MIL-PRF-38535

<b>STANDARD MICROCIRCUIT DRAWING</b> DEFENSE SUPPLY CENTER COLUMBUS COLUMBUS, OHIO 43218-3990	SIZE <b>A</b>		<b>5962-87663</b>
		REVISION LEVEL F	SHEET 27

APPENDIX A  
APPENDIX A FORMS A PART OF SMD 5962-87663

A.1.2.4 Die details. The die details designation is a unique letter which designates the die's physical dimensions, bonding pad location(s) and related electrical function(s), interface materials, and other assembly related information, for each product and variant supplied to this appendix.

A.1.2.4.1 Die physical dimensions.

<u>Die type</u>	<u>Figure number</u>
03	A-1

A.1.2.4.2 Die bonding pad locations and electrical functions.

<u>Die type</u>	<u>Figure number</u>
03	A-1

A.1.2.4.3 Interface materials.

<u>Die type</u>	<u>Figure number</u>
03	A-1

A.1.2.4.4 Assembly related information.

<u>Die type</u>	<u>Figure number</u>
03	A-1

A.1.3 Absolute maximum ratings. See paragraph 1.3 herein for details.

A.1.4 Recommended operating conditions. See paragraph 1.4 herein for details.

<b>STANDARD MICROCIRCUIT DRAWING</b> DEFENSE SUPPLY CENTER COLUMBUS COLUMBUS, OHIO 43218-3990	SIZE <b>A</b>	REVISION LEVEL F	<b>5962-87663</b>  SHEET 28

APPENDIX A  
APPENDIX A FORMS A PART OF SMD 5962-87663

A.2. APPLICABLE DOCUMENTS

A.2.1 Government specification, standards, and handbooks. The following specification, standard, and handbooks form a part of this drawing to the extent specified herein. Unless otherwise specified, the issues of these documents are those cited in the solicitation or contract.

DEPARTMENT OF DEFENSE SPECIFICATION

MIL-PRF-38535 - Integrated Circuits, Manufacturing, General Specification for.

DEPARTMENT OF DEFENSE STANDARD

MIL-STD-883 - Test Method Standard Microcircuits.

DEPARTMENT OF DEFENSE HANDBOOKS

MIL-HDBK-103 - List of Standard Microcircuit Drawings.  
MIL-HDBK-780 - Standard Microcircuit Drawings.

(Copies of these documents are available online at <http://assist.daps.dla.mil/quicksearch/> or <http://assist.daps.dla.mil> or from the Standardization Document Order Desk, 700 Robbins Avenue, Building 4D, Philadelphia, PA 19111-5094.)

A.2.2 Order of precedence. In the event of a conflict between the text of this drawing and the references cited herein, the text of this drawing takes precedence. Nothing in this document, however, supersedes applicable laws and regulations unless a specific exemption has been obtained.

A.3 REQUIREMENTS

A.3.1 Item requirements. The individual item requirements for device classes Q and V shall be in accordance with MIL-PRF-38535 and as specified herein or as modified in the device manufacturer's Quality Management (QM) plan. The modification in the QM plan shall not affect the form, fit, or function as described herein.

A.3.2 Design, construction and physical dimensions. The design, construction, and physical dimensions shall be as specified in MIL-PRF-38535 and herein and the manufacturer's QM plan for device classes Q and V.

A.3.2.1 Die physical dimensions. The die physical dimensions shall be as specified in A.1.2.4.1 and on figure A-1.

A.3.2.2 Die bonding pad locations and electrical functions. The die bonding pad locations and electrical functions shall be as specified in A.1.2.4.2 and on figure A-1.

A.3.2.3 Interface materials. The interface materials for the die shall be as specified in A.1.2.4.3 and on figure A-1.

A.3.2.4 Assembly related information. The assembly related information shall be as specified in A.1.2.4.4 and on figure A-1.

A.3.2.5 Truth table. The truth table shall be as defined in paragraph 3.2.3 herein.

A.3.2.6 Radiation exposure circuit. The radiation exposure circuit shall be as defined in paragraph 3.2.7 herein.

A.3.3 Electrical performance characteristics and post-irradiation parameter limits. Unless otherwise specified herein, the electrical performance characteristics and post-irradiation parameter limits are as specified in table IA of the body of this document.

A.3.4 Electrical test requirements. The wafer probe test requirements shall include functional and parametric testing sufficient to make the packaged die capable of meeting the electrical performance requirements in table IA.

<b>STANDARD MICROCIRCUIT DRAWING</b> DEFENSE SUPPLY CENTER COLUMBUS COLUMBUS, OHIO 43218-3990	SIZE <b>A</b>		<b>5962-87663</b>
		REVISION LEVEL F	SHEET 29

APPENDIX A  
APPENDIX A FORMS A PART OF SMD 5962-87663

A.3.5 Marking. As a minimum, each unique lot of die, loaded in single or multiple stack of carriers, for shipment to a customer, shall be identified with the wafer lot number, the certification mark, the manufacturer's identification and the PIN listed in A.1.2 herein. The certification mark shall be a "QML" or "Q" as required by MIL-PRF-38535.

A.3.6 Certification of compliance. For device classes Q and V, a certificate of compliance shall be required from a QML-38535 listed manufacturer in order to supply to the requirements of this drawing (see A.6.4 herein). The certificate of compliance submitted to DSCC-VA prior to listing as an approved source of supply for this appendix shall affirm that the manufacturer's product meets, for device classes Q and V, the requirements of MIL-PRF-38535 and the requirements herein.

A.3.7 Certificate of conformance. A certificate of conformance as required for device classes Q and V in MIL-PRF-38535 shall be provided with each lot of microcircuit die delivered to this drawing.

A.4 VERIFICATION

A.4.1 Sampling and inspection. For device classes Q and V, die sampling and inspection procedures shall be in accordance with MIL-PRF-38535 or as modified in the device manufacturer's Quality Management (QM) plan. The modifications in the QM plan shall not affect the form, fit, or function as described herein.

A.4.2 Screening. For device classes Q and V, screening shall be in accordance with MIL-PRF-38535, and as defined in the manufacturer's QM plan. As a minimum, it shall consist of:

- a. Wafer lot acceptance for class V product using the criteria defined in MIL-STD-883, method 5007.
- b. 100% wafer probe (see paragraph A.3.4 herein).
- c. 100% internal visual inspection to the applicable class Q or V criteria defined in MIL-STD-883, method 2010 or the alternate procedures allowed in MIL-STD-883, method 5004.

A.4.3 Conformance inspection.

A.4.3.1 Group E inspection. Group E inspection is required only for parts intended to be identified as radiation assured (see A.3.5 herein). RHA levels for device classes Q and V shall be as specified in MIL-PRF-38535. End point electrical testing of packaged die shall be as specified in table IIA herein. Group E tests and conditions are as specified in paragraphs 4.4.4 herein.

A.5 DIE CARRIER

A.5.1 Die carrier requirements. The requirements for the die carrier shall be accordance with the manufacturer's QM plan or as specified in the purchase order by the acquiring activity. The die carrier shall provide adequate physical, mechanical and electrostatic protection.

A.6 NOTES

A.6.1 Intended use. Microcircuit die conforming to this drawing are intended for use in microcircuits built in accordance with MIL-PRF-38535 or MIL-PRF-38534 for government microcircuit applications (original equipment), design applications, and logistics purposes.

A.6.2 Comments. Comments on this appendix should be directed to DSCC-VA, Columbus, Ohio 43218-3990 or telephone (614) 692-0547.

A.6.3 Abbreviations, symbols, and definitions. The abbreviations, symbols, and definitions used herein are defined in MIL-PRF-38535 and MIL-HDBK-1331.

A.6.4 Sources of supply for device classes Q and V. Sources of supply for device classes Q and V are listed in QML-38535. The vendors listed within QML-38535 have submitted a certificate of compliance (see A.3.6 herein) to DSCC-VA and have agreed to this drawing.

<b>STANDARD MICROCIRCUIT DRAWING</b> DEFENSE SUPPLY CENTER COLUMBUS COLUMBUS, OHIO 43218-3990	SIZE <b>A</b>		<b>5962-87663</b>
		REVISION LEVEL F	SHEET 30

APPENDIX A  
APPENDIX A FORMS A PART OF SMD 5962-87663

Die physical dimensions.

Die size: 2408 x 2250  $\mu\text{m}$   
Die thickness: 285  $\pm$ 25  $\mu\text{m}$

Die bonding pad locations and electrical functions.

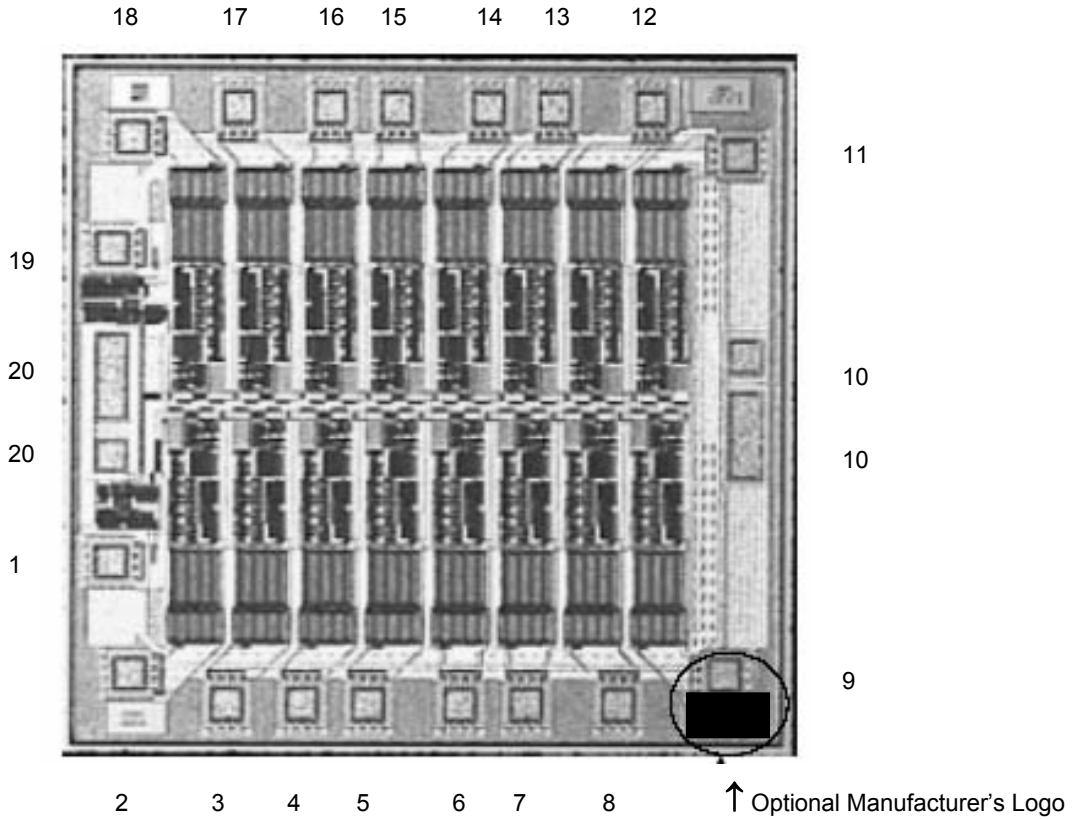

Pad size: Pad numbers 1 to 9 and 11 to 19: 100 x 100  $\mu\text{m}$   
Pad numbers 10 (GND) and 20 ( $V_{CC}$ ): 100 x 280  $\mu\text{m}$

NOTE: Pad numbers reflect terminal numbers when placed in case outline X (see figure 1).

FIGURE A-1

<b>STANDARD MICROCIRCUIT DRAWING</b> DEFENSE SUPPLY CENTER COLUMBUS COLUMBUS, OHIO 43218-3990	SIZE <b>A</b>		<b>5962-87663</b>
		REVISION LEVEL <b>F</b>	SHEET 31

APPENDIX A  
APPENDIX A FORMS A PART OF SMD 5962-87663

Interface materials.

Top metallization:                   Al Si Cu                   0.85 μm

Backside metallization:           None

Glassivation.

    Type:                               P. Vapox + Nitride  
    Thickness:                        0.5 μm – 0.7 μm

Substrate:                            Silicon

Assembly related information.

Substrate potential:               Floating or tied to GND

Special assembly instructions:   Bond pad #20 (V<sub>CC</sub>) first

FIGURE A-1 – Continued.

<b>STANDARD MICROCIRCUIT DRAWING</b> DEFENSE SUPPLY CENTER COLUMBUS COLUMBUS, OHIO 43218-3990	SIZE <b>A</b>	<b>5962-87663</b>
	REVISION LEVEL <b>F</b>	SHEET <b>32</b>



## STANDARD MICROCIRCUIT DRAWING BULLETIN

DATE: 07-05-25

Approved sources of supply for SMD 5962-87663 are listed below for immediate acquisition information only and shall be added to MIL-HDBK-103 and QML-38535 during the next revision. MIL-HDBK-103 and QML-38535 will be revised to include the addition or deletion of sources. The vendors listed below have agreed to this drawing and a certificate of compliance has been submitted to and accepted by DSCC-VA. This information bulletin is superseded by the next dated revision of MIL-HDBK-103 and QML-38535. DSCC maintains an online database of all current sources of supply at <http://www.dscclia.mil/Programs/Smcr/>.

Standard microcircuit drawing PIN <u>1/</u>	Vendor CAGE number	Vendor similar PIN <u>2/</u>
5962-8766301RA	0C7V7	54ACT245DMQB
5962-8766301SA	0C7V7	54ACT245FMQB
5962-87663012A	0C7V7	54ACT245LMQB
5962-8766301MRA	01295 0C7V7	SNJ54ACT245J 54ACT245DMQB
5962-8766301MSA	27014 01295 0C7V7	54ACT245FMQB SNJ54ACT245W 54ACT245FMQB
5962-8766301M2A	01295 0C7V7	SNJ54ACT245FK 54ACT245LMQB
5962-8766301BRA	0C7V7	JM54ACT245BRA
5962-8766301B2A	0C7V7	JM54ACT245B2A
5962-8766301BSA	0C7V7	JM54ACT245BSA
5962-8766301SRA	01295	SNV54ACT245J
5962-8766301SSA	01295	SNV54ACT245W
5962-8766301S2A	<u>3/</u>	54ACT245
5962-8766302M3A	3V146	54ACT11245/B3A
5962-8766302MLA	3V146	54ACT11245/BLA
5962-8766303QXA	<u>3/</u>	54ACT245K02Q
5962-8766303QXC	<u>3/</u>	54ACT245K01Q
5962-8766303VXA	<u>3/</u>	54ACT245K02V
5962-8766303VXC	<u>3/</u>	54ACT245K01V
5962R8766301BRA	<u>3/</u>	JM54ACT245BRA-R
5962R8766301BSA	<u>3/</u>	JM54ACT245BSA-R
5962R8766301B2A	<u>3/</u>	JM54ACT245B2A-R
5962R8766301SRA	27014	JM54ACT245SRA-R
5962R8766301SSA	27014	JM54ACT245SSA-R
5962R8766301S2A	27014	JM54ACT245S2A-R
5962F8766303QXA	F8859	RHFACT245K02Q
5962F8766303QXC	F8859	RHFACT245K01Q
5962F8766303VXA	F8859	RHFACT245K02V
5962F8766303VXC	F8859	RHFACT245K01V
5962F8766303QRA	F8859	RHFACT245D04Q
5962F8766303QRC	F8859	RHFACT245D03Q
5962F8766303VRA	F8859	RHFACT245D04V
5962F8766303VRC	F8859	RHFACT245D03V
5962F8766303V9A	F8859	ACT245DIE2V

See footnotes on next sheet.

STANDARD MICROCIRCUIT DRAWING BULLETIN – Continued.

- 1/ The lead finish shown for each PIN representing a hermetic package is the most readily available from the manufacturer listed for that part. If the desired lead finish is not listed, contact the vendor to determine its availability.
- 2/ Caution. Do not use this number for item acquisition. Items acquired to this number may not satisfy the performance requirements of this drawing.
- 3/ Not available from an approved source of supply.

<u>Vendor CAGE number</u>	<u>Vendor name and address</u>
27014	National Semiconductor 2900 Semiconductor Drive P.O. Box 58090 Santa Clara, CA 95052-8090
01295	Texas Instruments Inc. Semiconductor Group 8505 Forest Ln. P.O. Box 660199 Dallas, TX 75243 Point of contact: U.S. Highway 75 South P.O. Box 84, M/S 853 Sherman, TX 75090-9493
F8859	ST Microelectronics 3 rue de Suisse CS 60816 35208 RENNES cedex2 – France
3V146	Rochester Electronics 16 Malcolm Hoyt Drive Newburyport, MA 01950
0C7V7	QP Semiconductor 2945 Oakmead Village Court Santa Clara, CA 95051

The information contained herein is disseminated for convenience only and the Government assumes no liability whatsoever for any inaccuracies in the information bulletin.