

Dual Output Low Dropout Regulator

DESCRIPTION

The SiP2214 is a dual output low dropout regulator capable of supplying 150 mA from output 1 and 300 mA from output 2. In addition to the LDOs, an open drain output has been included, which is capable of sinking 150 mA. The SiP2214 offers a low dropout, low ground current and extremely low noise with the addition of a bypass capacitor.

Protection features include POR with adjustable delay, undervoltage lockout, output current limit, and thermal shutdown.

The fixed output version of SiP2214 is available in the MLP33-10 PowerPAK package and the adjustable version is available in the MLP44-16 PowerPAK package. Both packages are specified to operate over the range of - 40 °C to 85 °C.

FEATURES

- 2.25 V to 5.5 V input voltage range
- Two outputs - 150 mA and 300 mA
- Low ground current
- Open drain driver output
- POR
- Current limit
- Thermal shutdown
- MLP33-10 and MLP44-16 PowerPAK[®] packages



APPLICATIONS

- Cellular phones
- Wireless modems
- PDAs

TYPICAL APPLICATION CIRCUIT

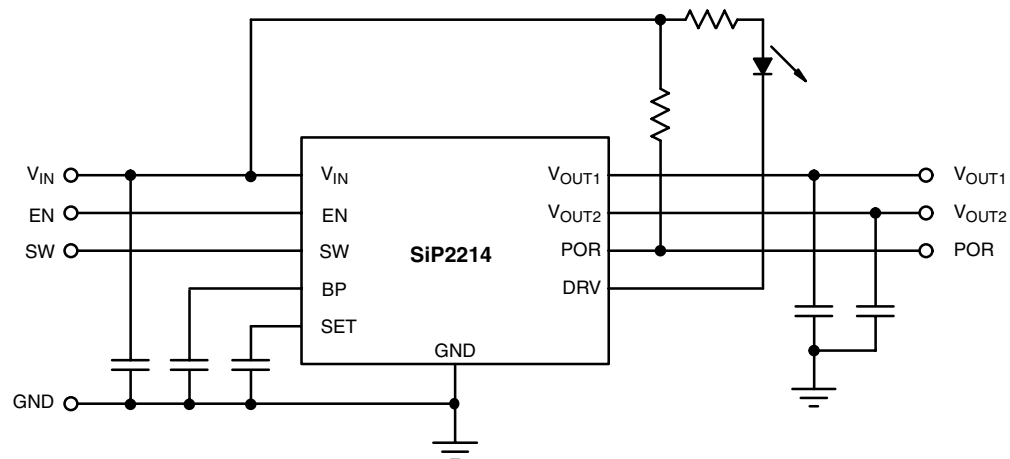

ABSOLUTE MAXIMUM RATINGS			
Parameter		Limit	Unit
V_{IN} , V_{EN} , to GND		- 0.3 to 7	V
Power Dissipation	MLP33-10 PowerPAK ^b	1600	mW
	MLP44-16 PowerPAK ^c	1880	
Storage Temperature		- 55 to 150	°C
Thermal Resistance	MLP33-10 PowerPAK ^a	50	°C/W
	MLP44-16 PowerPAK ^a	43	

Notes:

a. Device mounted with all leads soldered or welded to PC board.

b. Derate 20 mW/°C above 70 °C.

c. Derate 23.5 mW/°C above 70 °C.

Stresses beyond those listed under "Absolute Maximum Ratings" may cause permanent damage to the device. These are stress ratings only, and functional operation of the device at these or any other conditions beyond those indicated in the operational sections of the specifications is not implied. Exposure to absolute maximum rating conditions for extended periods may affect device reliability.

RECOMMENDED OPERATING RANGE			
Parameter		Limit	Unit
Input Voltage Range		2.25 to 5.5	V
Enable Voltage Range		0 to 5.5	
Operating Temperature Range T_A		- 40 to 85	°C
Operating Temperature Range T_J		- 40 to 125	

SPECIFICATIONS							
Parameter	Symbol	Test Conditions Unless Specified $V_{IN} = V_{OUT} + 1 V^f$, $C_{OUT} = 1 \mu F$, $I_{OUT} = 100 \mu A$ $T_A = 25 \text{ }^\circ\text{C}$	Temp. ^a	Limits			Unit
				Min. ^b	Typ. ^c	Max. ^b	
Regulators							
Output Voltage Accuracy		From Nominal V_{OUT}	Room	- 1		1	%
			Full	- 2		2	
Output Voltage Temperature Coefficient			Room		40		ppm/°C
Line Regulation ^f		$V_{IN} = V_{OUT} + 1 V$ to 5.5 V	Room	- 0.3	0.2	0.3	%
			Full	- 0.6		0.6	
Load Regulation		$I_{OUT} = 100 \mu A$ to 150 mA (LDO 1 and 2) $I_{OUT} = 100 \mu A$ to 300 mA (LDO 2)	Room		0.2	1.0	%
			Room			1.5	
Dropout Voltage ^g	V_{DROP}	$I_{OUT} = 150 \text{ mA}$ (LDO 1 and 2)	Room		120	190	mV
			Full			250	
		$I_{OUT} = 300 \text{ mA}$ (LDO 2)	Room		240	340	
			Full			420	
Ground Pin Current	I_G	$I_{OUT1} = I_{OUT2} = 0 \mu A$	Room		48	65	μA
			Full			80	
		$I_{OUT1} = 150 \text{ mA}$, $I_{OUT2} = 300 \text{ mA}$	Room		60		
			Full			2.0	
Output Voltage Noise					30	μV_{rms}	
Ripple Rejection		$f = 1 \text{ kHz}$, $C_{OUT} = 1 \mu F$, $C_{BP} = 10 \text{ nF}$ $f = 20 \text{ kHz}$, $C_{OUT} = 1 \mu F$, $C_{BP} = 10 \text{ nF}$	Room		60		dB
			Room		40		
Inputs							
EN, SW Input Voltage	V_{IL}	Logic Low	Full			0.6	V
	V_{IH}	Logic High	Full	1.8			
EN, SW Input Current	I_{IL}	$V_{IL} < 0.6 \text{ V}$	Room	- 1	0.01	1	μA
	I_{IH}	$V_{IH} > 1.8 \text{ V}$	Room	- 1	0.01	1	
SET Pin Threshold Voltage	$V_{TH(set)}$	POR = High	Room		1.25		V
SET Pin Current Source		$V_{SET} = 0 \text{ V}$	Room	0.75	1.25	1.75	μA

SPECIFICATIONS							
Parameter	Symbol	Test Conditions Unless Specified $V_{IN} = V_{OUT} + 1\text{ V}^f$, $C_{OUT} = 1\ \mu\text{F}$, $I_{OUT} = 100\ \mu\text{A}$, $T_A = 25\ ^\circ\text{C}$	Temp. ^a	Limits			Unit
				Min. ^b	Typ. ^c	Max. ^b	
Power On Reset (POR) Output							
Threshold	V_{THL}	% of Nominal V_{OUT2}	Room	90			%
	V_{THH}		Room			96	
Output Voltage	V_{OL}	$I_L = 250\ \mu\text{A}$	Room		0.02	0.1	V
Leakage Current	I_{POR}	POR = High	Room	- 1	0.01	1	μA
Driver (DRV) Output							
Output Voltage	V_{OL}	$I_L = 150\ \text{mA}$	Full		0.2	0.6	V
Leakage Current		$I_{DRV} = 0\ \text{mA}$, $V_{DRV} = 5.5\ \text{V}$, $SW = 0\ \text{V}$	Room	- 1	0.01	1	μA
Protection							
Current Limit	I_{IL}	$V_{OUT1} = 0\ \text{V}$	Room	150	280	460	mA
		$V_{OUT2} = 0\ \text{V}$	Room	300	450	700	
Thermal Shutdown Temperature			Room		165		$^\circ\text{C}$
Thermal Hysteresis			Room		25		

Notes:

- a. Room = 25 °C, Full = - 40 °C to 85 °C.
- b. The algebraic convention whereby the most negative value is a minimum and the most positive a maximum.
- c. Typical values are for DESIGN AID ONLY, not guaranteed nor subject to production testing.
- d. Timing is measured from 90 % of LDO #1's final value to 90 % of LDO #2's final value.
- e. Guaranteed by design.
- f. For higher output of the regulator pair.
- g. Dropout voltage is defined as the input to output differential voltage at which the output voltage drops 2 % below the output voltage measured with a 1 V differential, provided that V_{IN} does not drop below 2.25 V. When $V_{OUT(nom)}$ is less than 2.25 V, the output will be in regulation when $2.25\ \text{V} - V_{OUT(nom)}$ is greater than the dropout voltage specified.

FUNCTIONAL BLOCK DIAGRAM

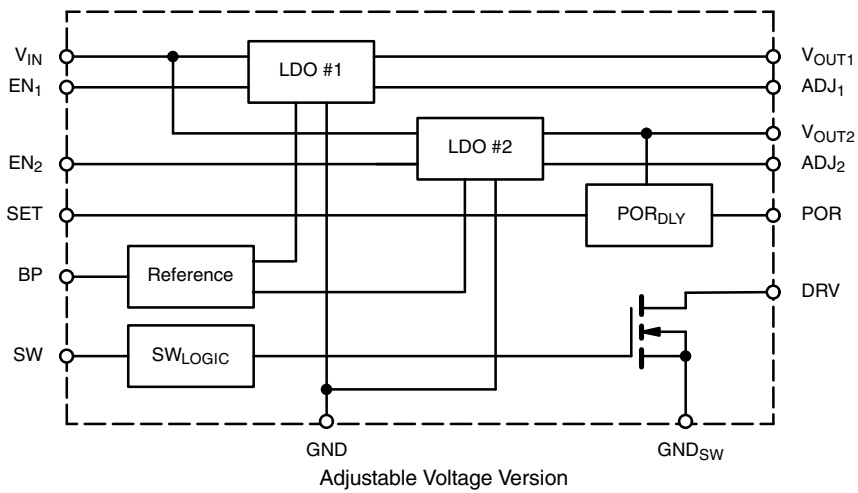
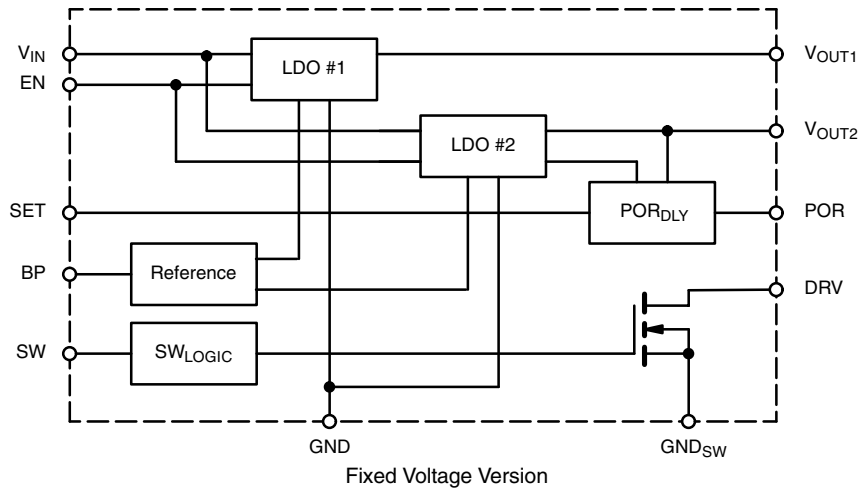

PIN CONFIGURATIONS AND ORDERING INFORMATION

PowerPAK MLP33-10 with Large Pad

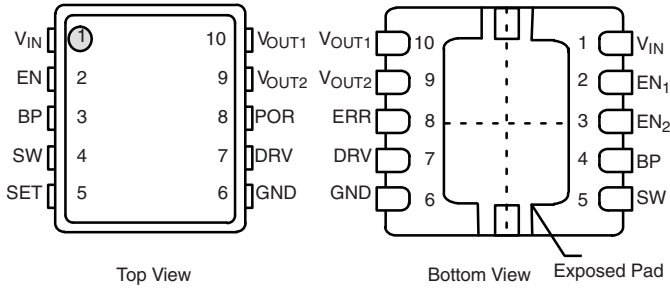

VOLTAGE OPTIONS	
Voltage	Code (x, z)
Adj	A
1.5	F
1.6	W
1.8	G
1.85	D
1.9	Y
2.0	H
2.1	E
2.5	J
2.6	K
2.7	L
2.8	M
2.85	N
2.9	O
3.0	P
3.1	Q
3.2	R
3.3	S
3.4	T
3.5	U
3.6	V

PowerPAK MLP44-16

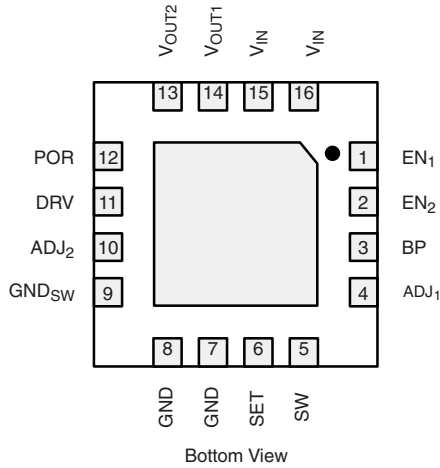

ORDERING INFORMATION			
Part Number	Temp. Range	Package	Marking
SiP2214DMP-XZ-T1	- 40 °C to 85 °C	PowerPAK MLP33-10	14XZ
SiP2214DLP-AA-T1		PowerPAK MLP44-16	14AA

X: Output 1 voltage code.
Z: Output 2 voltage code.

PIN DESCRIPTION			
Pin Number		Name	Function
MLP33-10	MLP44-16		
1	15, 16	V _{IN}	Input voltage for the power MOSFETs and their gate drive
2		EN	Enables both LDO outputs
	1	EN ₁	Enable LDO #1
	2	EN ₂	Enable LDO #2
3	3	BP	Bypass for noise reduction
4	5	SW	Control for open drain output
	4	ADJ ₁	Feedback connection for LDO #1
5	6	SET	Connection for external capacitor to delay POR
6	7, 8	GND	Ground
	9	GND _{SW}	Ground for the internal N-channel MOSFET switch
	10	ADJ ₂	Feedback connection for LDO #2
7	11	DRV	Open drain output
8	12	POR	Power on reset output
9	13	V _{OUT2}	Output of LDO #2 - 300 mA
10	14	V _{OUT1}	Output of LDO #1 - 150 mA

The exposed pad on both packages must be connected externally to the GND pin.

TYPICAL CHARACTERISTICS

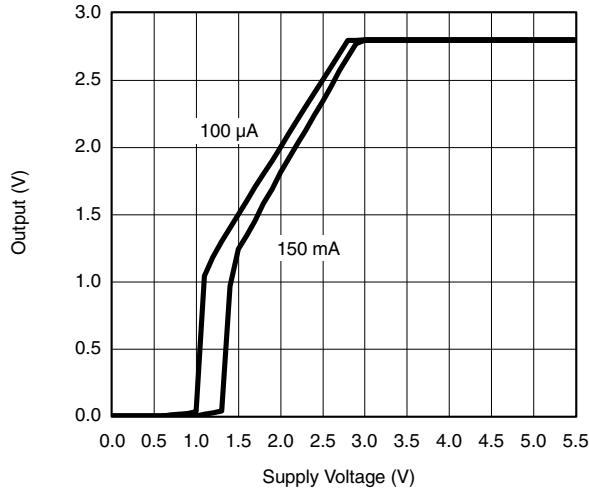

Dropout Characteristics - Output 1

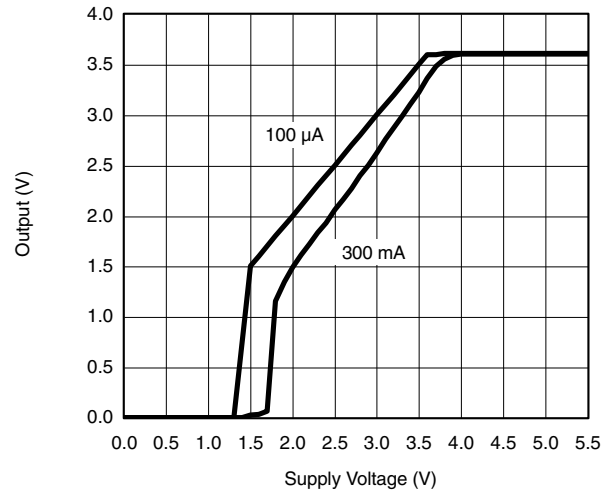

Dropout Characteristics - Output 2

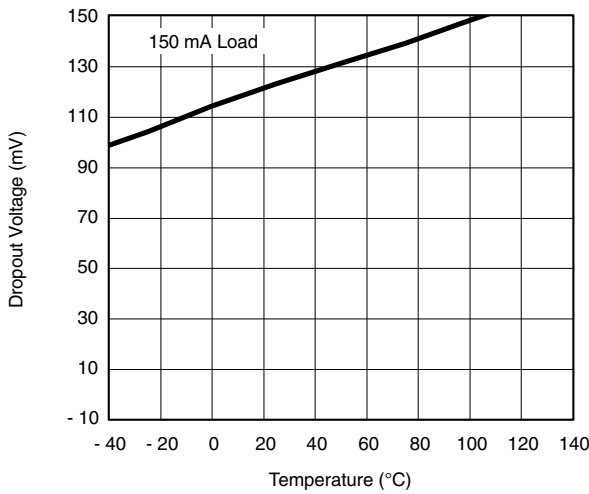

Dropout Voltage - Output 1

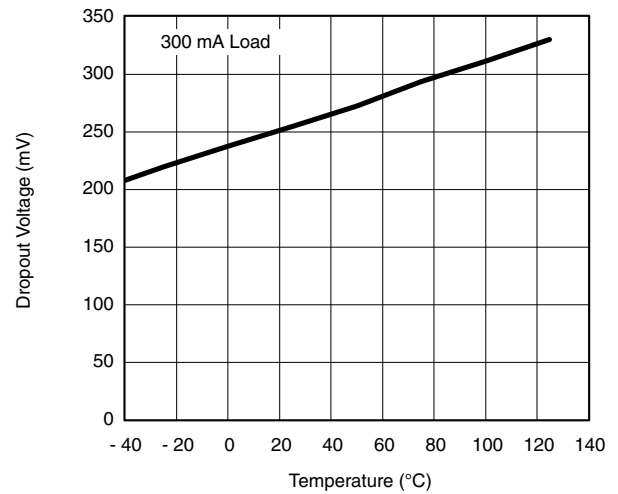

Dropout Voltage - Output 2

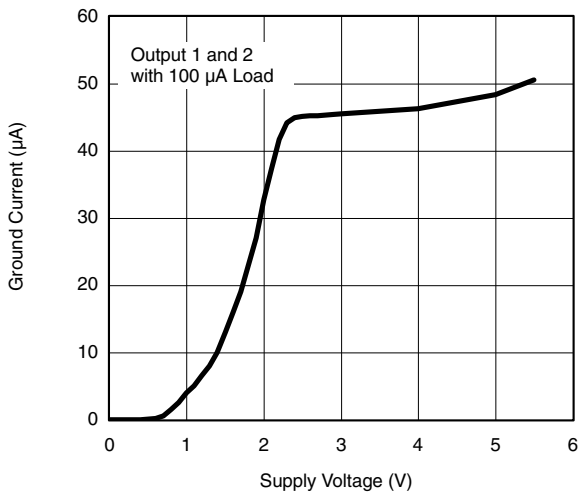

Ground Current vs. Supply Voltage

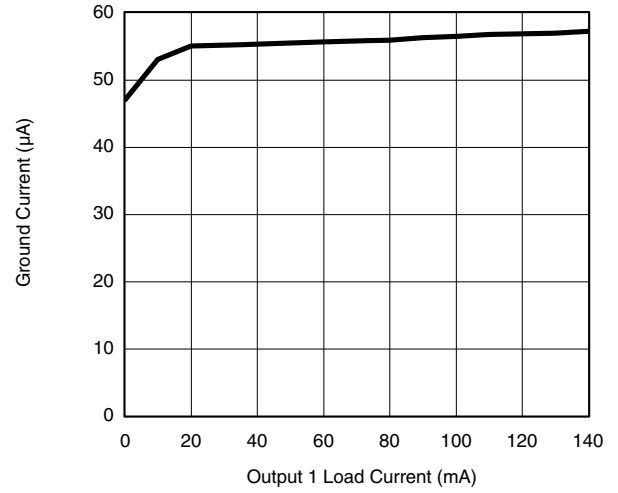

Ground Current vs. Output 1 Current

TYPICAL CHARACTERISTICS

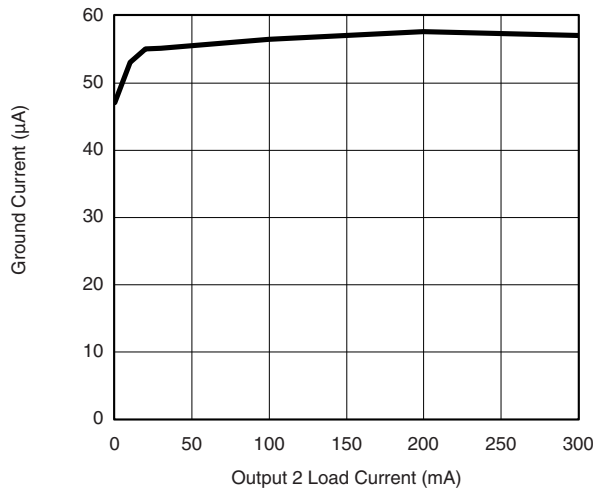

Ground Current vs. Output 2 Current

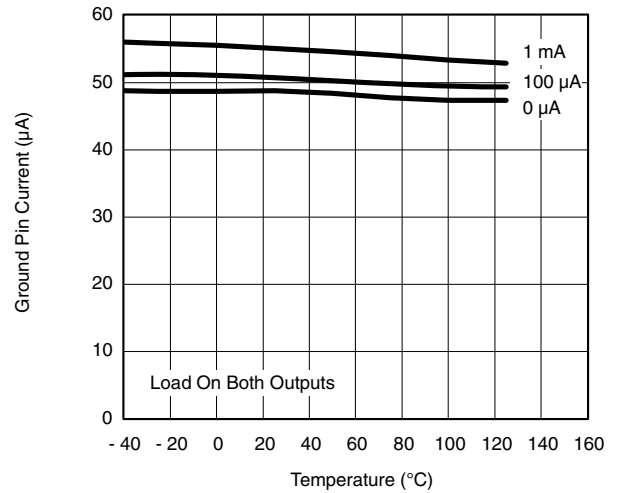

Ground Pin Current

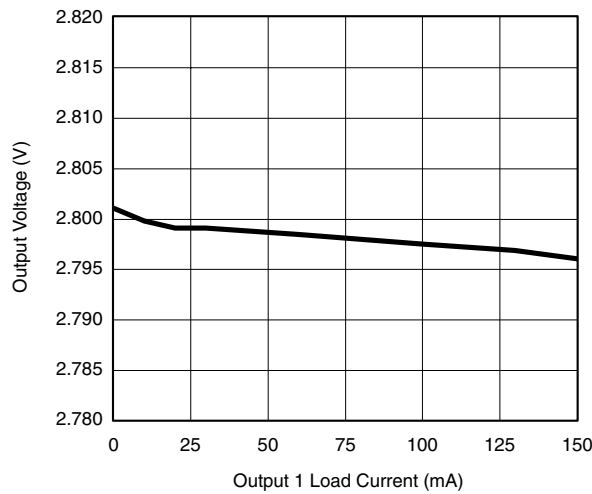

Output Voltage vs. Load Current - Output 1

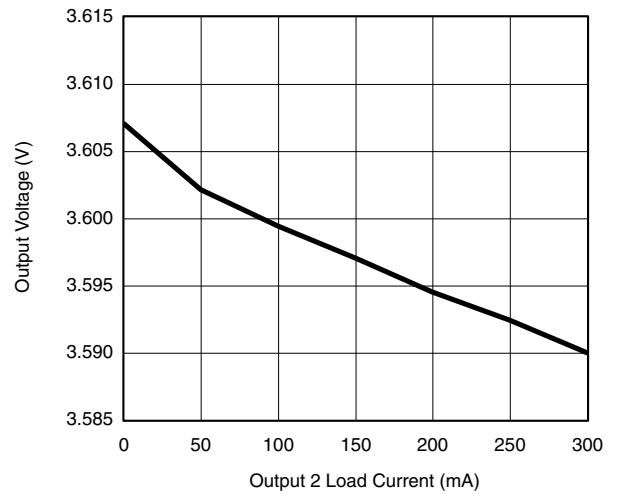

Output Voltage vs. Load Current - Output 2

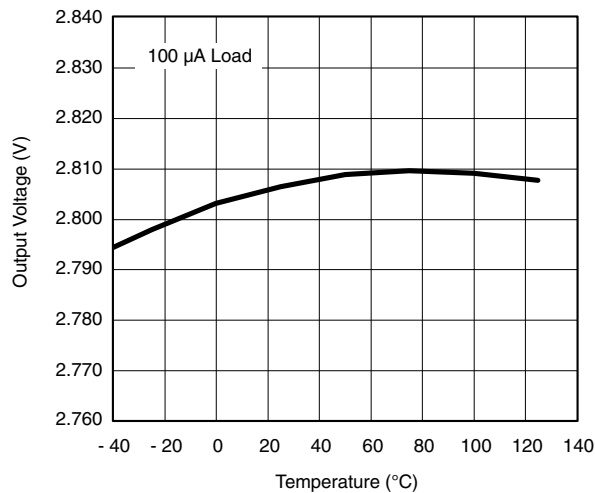

Output Voltage 1 vs. Temperature

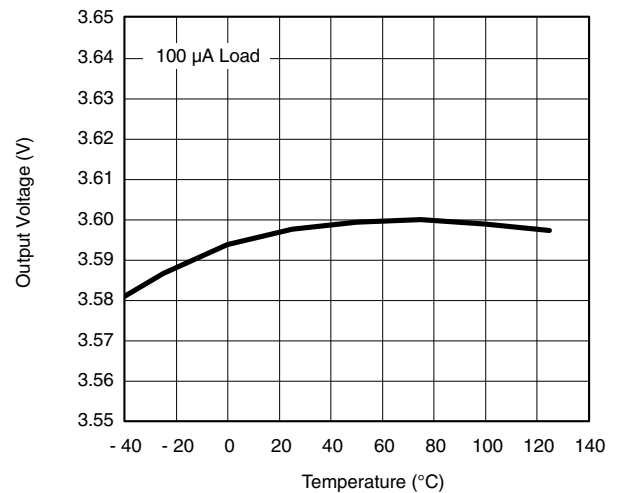

Output Voltage 2 vs. Temperature

TYPICAL CHARACTERISTICS

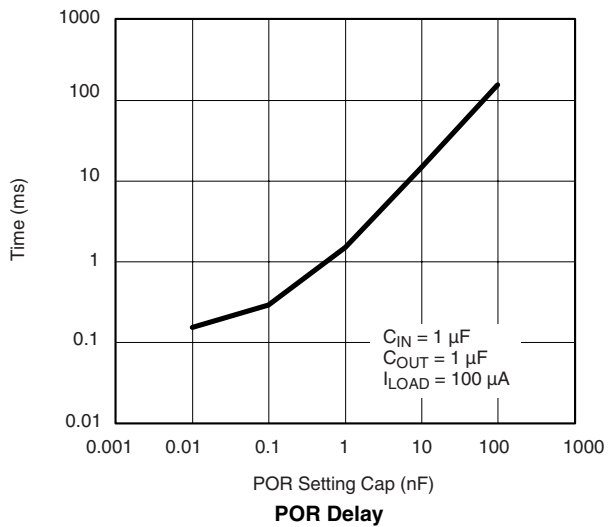
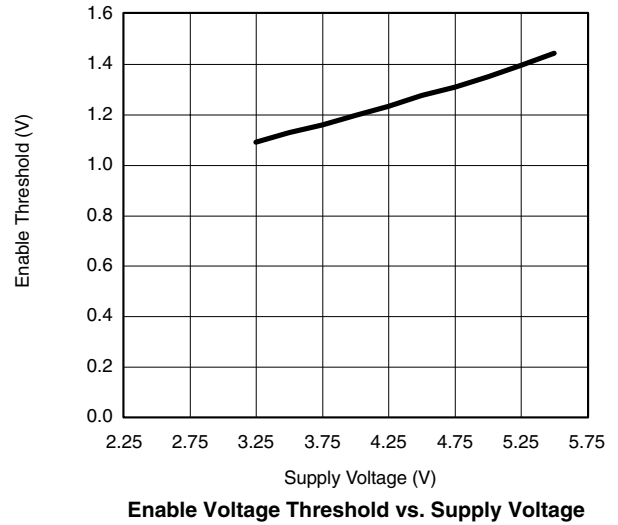
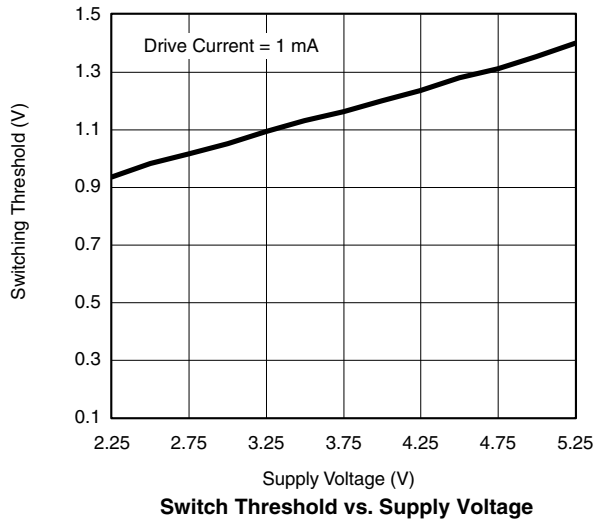

TYPICAL WAVEFORMS

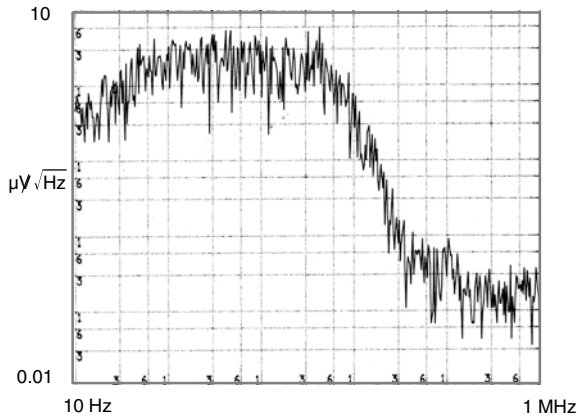

Noise Spectrum Output 1

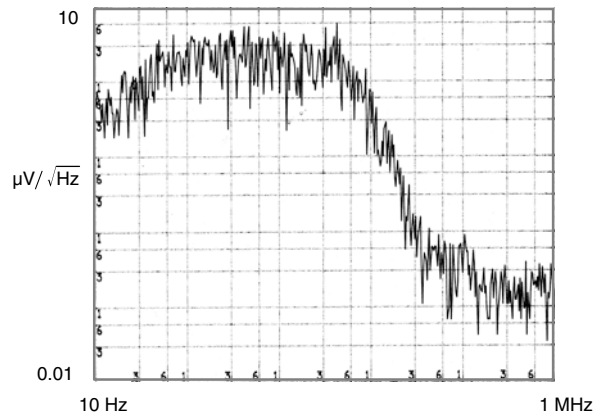

Noise Spectrum Output 2

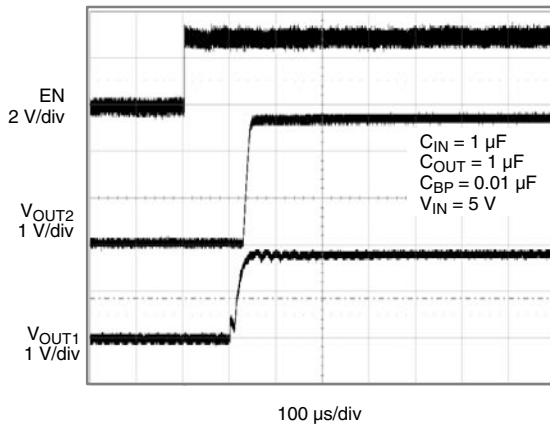

Enable Sequence

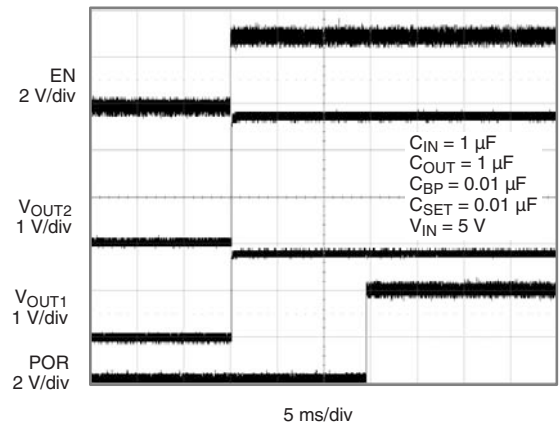

Power-On Reset Sequence

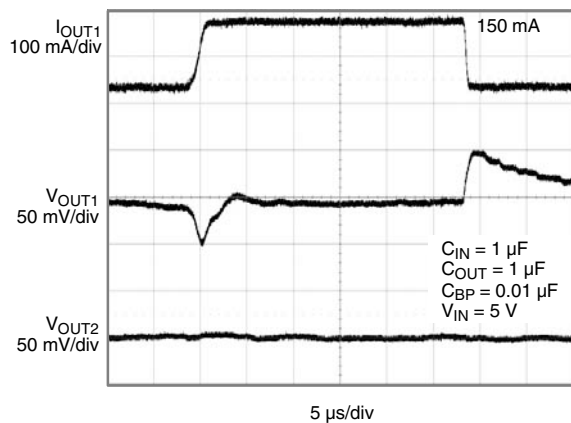

Load Transient Response LDO1

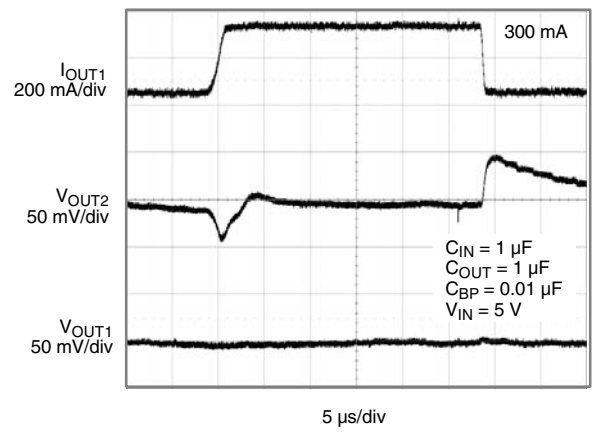

Load Transient Response LDO2

DETAILED OPERATION

The SiP2214 is a low drop out, low quiescent current monolithic dual linear regulator, with power-on reset and open drain driver output features. With output voltage range from 1.25 V to 5 V the first regulator can source 150 mA and the second regulator can source 300 mA. The open drain driver has the capability to drive LED's for backlighting applications.

V_{IN}

V_{IN} is the input supply pin for both LDO's. The bypass capacitor for this pin is not critical as long as the input supply has low enough source impedance. For practical circuits, a 1.0 μ F or larger ceramic capacitor is recommended. When the source impedance is not low enough and/or the source is several inches from the SiP2214, then a larger input bypass capacitor is needed. When the source impedance, wire and trace impedance are unknown, it is recommended that an input bypass capacitor be used of a value that is equal to or greater than the output capacitor.

$V_{OUT1,2}$ (LDO Outputs)

The V_{OUT} is the output voltage of the regulator. Connect a bypass capacitor from V_{OUTx} to ground. The output capacitor can be any value from 1.0 μ F to 10.0 μ F. A ceramic capacitor with X5R or X7R dielectric type is recommended for best output noise, line transient, and load transient performance.

Enable

The Enable pin controls the turning on and off of both regulators of the SiP2214. V_{OUT} of both outputs are guaranteed to be on when the Enable pin voltage is equal or greater than 1.8 V. V_{OUT} is guaranteed to be off when the

Enable pin voltage equals or is less than 0.6 V. To automatically turn on V_{OUT} whenever the Input is applied, tie the Enable pin to V_{IN} .

For the adjustable voltage version of the SiP2214, LDO₁ and LDO₂, have separate and independent Enable control pins.

Power-On Reset (POR)

The POR is an open drain output that goes low when V_{OUT2} is less than 5 % of its nominal value. As with any open drain output, an external pull up resistor is needed. The POR pin is disconnected if not used.

SET

When a capacitor is connected from SET to GROUND, the POR signal transition from low to high is delayed. This delayed POR signal can be used as the power-on reset signal for the application system. To set the POR delay time refer to the POR Delay curve to determine the capacitor value.

The Set pin should be an open circuit if not used.

OPEN-Drain Driver (DRV)

The SW pin a logic level input put that controls the DRV pin. The switch pin is an active high input and should not be left floating. The drive pin is an open drain output able to sink 150 mA of current.

Bypass Capacitor

For low noise application and/or increase in power supply rejection ration (PSRR) connect a high frequency ceramic capacitor from BP to ground. A 0.01 μ F X5R or X7R ceramic capacitor is recommended.



Disclaimer

ALL PRODUCT, PRODUCT SPECIFICATIONS AND DATA ARE SUBJECT TO CHANGE WITHOUT NOTICE TO IMPROVE RELIABILITY, FUNCTION OR DESIGN OR OTHERWISE.

Vishay Intertechnology, Inc., its affiliates, agents, and employees, and all persons acting on its or their behalf (collectively, "Vishay"), disclaim any and all liability for any errors, inaccuracies or incompleteness contained in any datasheet or in any other disclosure relating to any product.

Vishay makes no warranty, representation or guarantee regarding the suitability of the products for any particular purpose or the continuing production of any product. To the maximum extent permitted by applicable law, Vishay disclaims (i) any and all liability arising out of the application or use of any product, (ii) any and all liability, including without limitation special, consequential or incidental damages, and (iii) any and all implied warranties, including warranties of fitness for particular purpose, non-infringement and merchantability.

Statements regarding the suitability of products for certain types of applications are based on Vishay's knowledge of typical requirements that are often placed on Vishay products in generic applications. Such statements are not binding statements about the suitability of products for a particular application. It is the customer's responsibility to validate that a particular product with the properties described in the product specification is suitable for use in a particular application. Parameters provided in datasheets and/or specifications may vary in different applications and performance may vary over time. All operating parameters, including typical parameters, must be validated for each customer application by the customer's technical experts. Product specifications do not expand or otherwise modify Vishay's terms and conditions of purchase, including but not limited to the warranty expressed therein.

Except as expressly indicated in writing, Vishay products are not designed for use in medical, life-saving, or life-sustaining applications or for any other application in which the failure of the Vishay product could result in personal injury or death. Customers using or selling Vishay products not expressly indicated for use in such applications do so at their own risk and agree to fully indemnify and hold Vishay and its distributors harmless from and against any and all claims, liabilities, expenses and damages arising or resulting in connection with such use or sale, including attorneys fees, even if such claim alleges that Vishay or its distributor was negligent regarding the design or manufacture of the part. Please contact authorized Vishay personnel to obtain written terms and conditions regarding products designed for such applications.

No license, express or implied, by estoppel or otherwise, to any intellectual property rights is granted by this document or by any conduct of Vishay. Product names and markings noted herein may be trademarks of their respective owners.