



P-Channel JFETs

2N5114JAN/JANTX/JANTXV
2N5115JAN/JANTX/JANTXV
2N5116JAN/JANTX/JANTXV

Table with 5 columns: Part Number, VGS(off) (V), rDS(on) Max (Ω), ID(off) Typ (pA), tON Max (ns). Rows include 2N5114, 2N5115, and 2N5116.

FEATURES

- Low On-Resistance: 2N5114 <75 Ω
• Fast Switching—tON: 16 ns
• High Off-Isolation—ID(off): -10 pA
• Low Capacitance: 6 pF
• Low Insertion Loss

BENEFITS

- Low Error Voltage
• High-Speed Analog Circuit Performance
• Negligible "Off-Error," Excellent Accuracy
• Good Frequency Response
• Eliminates Additional Buffering

APPLICATIONS

- Analog Switches
• Choppers
• Sample-and-Hold
• Normally "On" Switches
• Current Limiters

DESCRIPTION

The 2N5114JAN/JANTX/JANTXV series consists of p-channel JFET analog switches designed to provide low on-resistance, good off-isolation, and fast switching. These

JFETs are optimized for use in complementary switching applications with the Vishay Siliconix 2N4856A series.

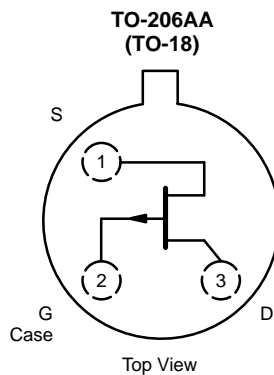

ABSOLUTE MAXIMUM RATINGS

Gate-Drain Voltage . . . . . 30 V
Gate-Source Voltage . . . . . 30 V
Gate Current . . . . . -50 mA
Storage Temperature . . . . . -65 to 200°C
Operating Junction Temperature . . . . . -55 to 200°C

Lead Temperature (1/16" from case for 10 sec.) . . . . . 300°C
Power Dissipationa . . . . . 500 mW

Notes
a. Derate 3 mW/°C above 25°C



SPECIFICATIONS (T <sub>A</sub> = 25 °C UNLESS OTHERWISE NOTED)												
Parameter	Symbol	Test Conditions	Typ <sup>a</sup>	Limits						Unit		
				2N5114		2N5115		2N5116				
				Min	Max	Min	Max	Min	Max			
<b>Static</b>												
Gate-Source Breakdown Voltage	V <sub>(BR)GSS</sub>	I <sub>G</sub> = 1 μA, V <sub>DS</sub> = 0 V	45	30		30		30		V		
Gate-Source Cutoff Voltage	V <sub>GS(off)</sub>	V <sub>DS</sub> = -15 V, I <sub>D</sub> = -1 nA		5	10	3	6	1	4			
Saturation Drain Current <sup>b</sup>	I <sub>DSS</sub>	V <sub>GS</sub> = 0 V		V <sub>DS</sub> = -18 V								
				V <sub>DS</sub> = -15 V			-15	-60	-5	-25	mA	
Gate Reverse Current	I <sub>GSS</sub>	V <sub>GS</sub> = 20 V, V <sub>DS</sub> = 0 V			500		500		500	pA		
				T <sub>A</sub> = 150 °C	0.01		1		1		1	μA
Gate Operating Current <sup>c</sup>	I <sub>G</sub>	V <sub>DG</sub> = -15 V, I <sub>D</sub> = -1 mA	-5									
Drain Cutoff Current	I <sub>D(off)</sub>	V <sub>DS</sub> = -15 V		V <sub>GS</sub> = 12 V	-10		-500			pA		
				V <sub>GS</sub> = 7 V	-10			-500				
				V <sub>GS</sub> = 5 V	-10					-500		
		V <sub>DS</sub> = -15 V T <sub>A</sub> = 150 °C		V <sub>GS</sub> = 12 V	-0.02		-1					μA
				V <sub>GS</sub> = 7 V	-0.02				-1			
				V <sub>GS</sub> = 5 V	-0.02						-1	
Drain-Source On-Voltage	V <sub>DS(on)</sub>	V <sub>GS</sub> = 0 V		I <sub>D</sub> = -15 mA	-1.0		-1.3					
				I <sub>D</sub> = -7 mA	-0.7			-0.8			V	
				I <sub>D</sub> = -3 mA	-0.5					-0.6		
Drain-Source On-Resistance	r <sub>DS(on)</sub>	V <sub>GS</sub> = 0 V, I <sub>D</sub> = -1 mA			75		100		150	Ω		
Gate-Source Forward Voltage	V <sub>GS(F)</sub>	I <sub>G</sub> = -1 mA, V <sub>DS</sub> = 0 V	-0.7		-1		-1		-1	V		
<b>Dynamic</b>												
Drain-Source On-Resistance	r <sub>ds(on)</sub>	V <sub>GS</sub> = 0 V, I <sub>D</sub> = 0 mA, f = 1 kHz			75		100		175	Ω		
Common-Source Input Capacitance	C <sub>iss</sub>	V <sub>DS</sub> = -15 V, V <sub>GS</sub> = 0 V f = 1 MHz	20		25		25		27	pF		
Common-Source Reverse Transfer Capacitance	C <sub>rss</sub>	V <sub>DS</sub> = 0 V f = 1 MHz		V <sub>GS</sub> = 12 V	5		7					
				V <sub>GS</sub> = 7 V	6			7				
				V <sub>GS</sub> = 5 V	6					7		
<b>Switching</b>												
Turn-On Time	t <sub>d(on)</sub>	See Switching Circuit			6		10		25	ns		
	t <sub>r</sub>				10		20		35			
Turn-Off Time	t <sub>d(off)</sub>				6		8		20			
	t <sub>f</sub>				15		30		60			

**Notes**

- a. Typical values are for DESIGN AID ONLY, not guaranteed nor subject to production testing.
- b. Pulse test: PW ≤ 300 μs duty cycle ≤ 3%.
- c. This parameter not registered with JEDEC.

PSCIA



SWITCHING TIME TEST CIRCUIT			
	2N5114	2N5115	2N5116
$V_{DD}$	-10 V	-6 V	-6 V
$V_{GG}$	20 V	12 V	8 V
$R_L^*$	430 $\Omega$	910 $\Omega$	2000 $\Omega$
$R_G^*$	100 $\Omega$	220 $\Omega$	390 $\Omega$
$I_{D(on)}$	-15 mA	-7 mA	-3 mA
$V_{GS(H)}$	0 V	0 V	0 V
$V_{GS(L)}$	-11 V	-7 V	-5 V

\*Non-inductive

**INPUT PULSE**

Rise Time < 1 ns  
 Fall Time < 1 ns  
 Pulse Width 100 ns  
 PRF 1 MHz

**SAMPLING SCOPE**

Rise Time 0.4 ns  
 Input Resistance 10 M $\Omega$   
 Input Capacitance 1.5 pF

See Typical Characteristics curves for changes.

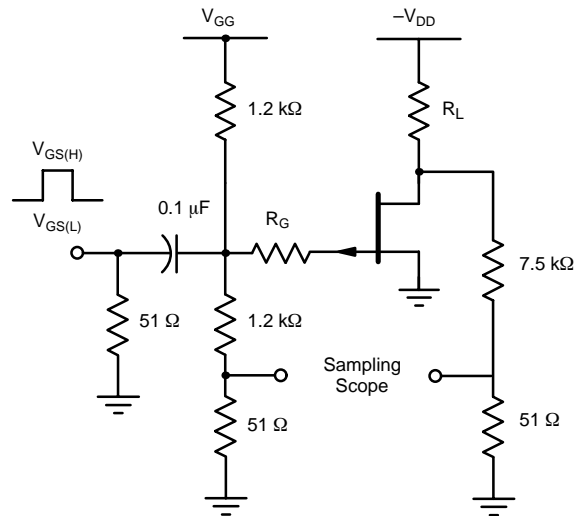



## Disclaimer

All product specifications and data are subject to change without notice.

Vishay Intertechnology, Inc., its affiliates, agents, and employees, and all persons acting on its or their behalf (collectively, "Vishay"), disclaim any and all liability for any errors, inaccuracies or incompleteness contained herein or in any other disclosure relating to any product.

Vishay disclaims any and all liability arising out of the use or application of any product described herein or of any information provided herein to the maximum extent permitted by law. The product specifications do not expand or otherwise modify Vishay's terms and conditions of purchase, including but not limited to the warranty expressed therein, which apply to these products.

No license, express or implied, by estoppel or otherwise, to any intellectual property rights is granted by this document or by any conduct of Vishay.

The products shown herein are not designed for use in medical, life-saving, or life-sustaining applications unless otherwise expressly indicated. Customers using or selling Vishay products not expressly indicated for use in such applications do so entirely at their own risk and agree to fully indemnify Vishay for any damages arising or resulting from such use or sale. Please contact authorized Vishay personnel to obtain written terms and conditions regarding products designed for such applications.

Product names and markings noted herein may be trademarks of their respective owners.