



## CAN Bus Driver and Receiver

### DESCRIPTION

The Si9200EY is designed to interface between the Intel 82526 CAN controller and the physical bus to provide drive capability to the bus and differential receive capability to the controller. It is designed to absorb typical electrical transients on the bus which may occur in an automotive or industrial application, and protect itself against any abnormal bus conditions. The transmitter will be disabled during these conditions and will be re-enabled when the abnormal condition is cleared.

The Si9200EY is built using the Siliconix BiC/DMOS process. This process supports CMOS, DMOS, and isolated bipolar transistors and uses an epitaxial layer to prevent latchup. The bus line pins are diode protected and can be driven beyond the  $V_{DD}$  to ground range.

The Si9200EY is offered in the space efficient 8-pin high-density surface-mount plastic package and is specified over the automotive temperature range (-40 °C to 125 °C). The Si9200EY is available in lead free.

### FEATURES

- Survives Ground Shorts and Transients on Multiplexed Bus in Automotive and Industrial Applications
- Single Power Supply
- Compatible with Intel 82526 CAN Controller
- Direct Interface - No External Components Required
- Automotive Temperature Range (-40 °C to 125 °C)

### PIN CONFIGURATION AND FUNCTIONAL BLOCK DIAGRAM

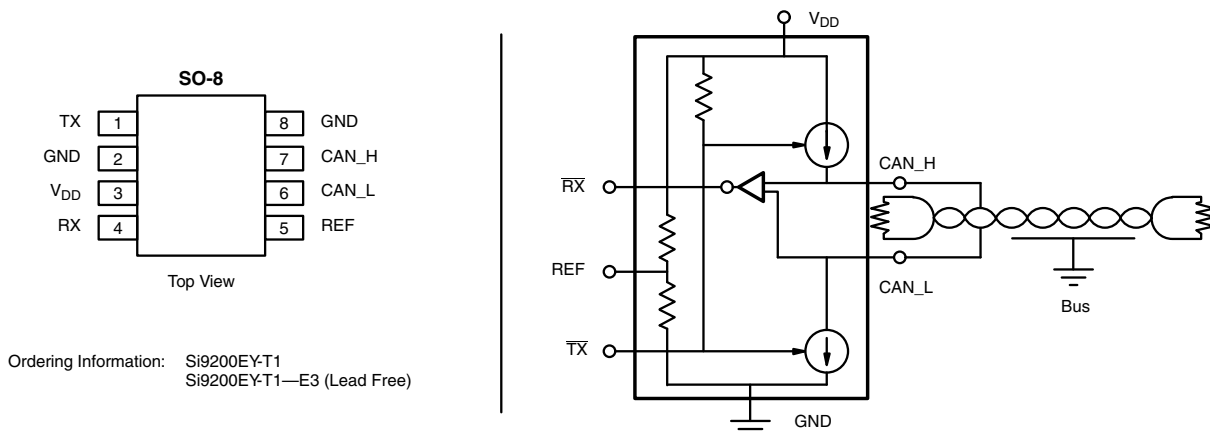

ABSOLUTE MAXIMUM RATINGS <sup>a</sup>		
Parameter	Limit	Unit
Operating Temperature (T <sub>A</sub> )	- 40 to 125	°C
Junction and Storage Temperature	- 55 to 150	
Voltage On Any Pin (except CAN_H and CAN_L) with Respect to Ground	- 0.3 to V <sub>DD</sub> + 0.3	V
Voltage On CAN_H and CAN_L with Respect to Ground	- 3 to 16	
Supply Voltage, V <sub>DD</sub>	- 0.3 to 12	
Continuous Output Current	± 100	mA
Thermal Ratings <sup>b</sup> : R <sub>thJA</sub>	62.5 (no airflow)	°C

## Notes:

a. Extended exposure to the absolute maximum ratings or stresses beyond these ratings may affect device reliability or may cause permanent damage to the device. Functional operation at conditions other than the recommended operating conditions is not implied.

b. Mounted on 1-IN<sup>2</sup>, FR4 PC Board.

RECOMMENDED OPERATING RANGE		
Parameter	Limit	Unit
V <sub>DD</sub>	4.75 to 5.25	V
Bus Load Resistance	60	Ω

SPECIFICATIONS						
Parameter	Symbol	Test Conditions Unless Otherwise Specified V <sub>DD</sub> = 4.75 V to 5.25 V	Limits T <sub>A</sub> = - 40 V to 125 °C			Unit
			Min. <sup>b</sup>	Typ. <sup>c</sup>	Max. <sup>b</sup>	
<b>Input</b>						
$\overline{\text{TX}}$ Input Voltage High	V <sub>INH</sub>		4			V
$\overline{\text{TX}}$ Input Voltage Low	V <sub>INL</sub>				1	
$\overline{\text{TX}}$ Input Current Low	I <sub>IL</sub>	$\overline{\text{TX}} = 0 \text{ V}$	- 50		- 2	μA
$\overline{\text{TX}}$ Input Current High	I <sub>IH</sub>	$\overline{\text{TX}} = V_{DD}$	- 1		1	
<b>Output</b>						
Bus Recessive	V <sub>CAN_HR</sub> , V <sub>CAN_LR</sub>	$\overline{\text{TX}} = V_{INH}$ , R <sub>L</sub> = ∞	2	2.5	3	V
	V <sub>DIF</sub> = V <sub>CAN_HR</sub> - V <sub>CAN_LR</sub>		- 0.5	0	0.05	
Bus Dominant	V <sub>CAN_HD</sub>	$\overline{\text{TX}} = V_{INL}$ , R <sub>L</sub> = 60 Ω	2.75	3.5	4.5	
	V <sub>CAN_LD</sub>		0.5	1.5	2.25	
	V <sub>DIF</sub> = V <sub>CAN_HD</sub> - V <sub>CAN_LD</sub>		1.5	2	3	
Reference Output	V <sub>REF</sub>	- 25 μA ≤ I <sub>REF</sub> ≤ 25 μA	0.5 V <sub>DD</sub> - 0.2	0.5 V <sub>DD</sub>	0.5 V <sub>DD</sub> + 0.2	
Receive Output (Bus Recessive Conditions)	V <sub>RXH</sub>	$\overline{\text{TX}} = V_{INH}$ - 2 ≤ V <sub>CAN_H</sub> , V <sub>CAN_L</sub> ≤ 7 - 1 ≤ V <sub>CAN_H</sub> - V <sub>CAN_L</sub> ≤ 0.5 (Bus Recessive)	I <sub>OUT</sub> = - 10 μA	V <sub>DD</sub> - 0.3	V <sub>DD</sub> - 0.05	
			I <sub>OUT</sub> = - 100 μA	V <sub>DD</sub> - 1	V <sub>DD</sub> - 0.2	
			I <sub>OUT</sub> = - 2 mA	V <sub>DD</sub> - 1.75	V <sub>DD</sub> - 1	
Receive Output (Bus Dominant Conditions)	V <sub>RXL</sub>	$\overline{\text{TX}} = V_{INH}$ - 0.8 ≤ V <sub>CAN_H</sub> ≤ 7 - 2 ≤ V <sub>CAN_L</sub> ≤ 5.8 0.9 ≤ V <sub>CAN_H</sub> - V <sub>CAN_L</sub> ≤ 5 (Bus Dominant)	I <sub>OUT</sub> = 10 μA		0.05	0.3
			I <sub>OUT</sub> = 100 μA		0.2	1
			I <sub>OUT</sub> = 2 mA		1	1.75
Internal Resistance from Bus Pins	R <sub>IN</sub> , BUS_L	$\overline{\text{TX}} = V_{INH}$ (Recessive)	5		50	kΩ
	R <sub>IN</sub> , BUS_H		5		50	
	R <sub>DIFF</sub>		10		100	
Internal Capacitance from Bus Pins <sup>c</sup>	C <sub>IN</sub> (CAN_H, CAN_L)				50	pF



SPECIFICATIONS						
Parameter	Symbol	Test Conditions Unless Otherwise Specified $V_{DD} = 4.75\text{ V to }5.25\text{ V}$	Limits $T_A = -40\text{ V to }125\text{ °C}$			Unit
			Min. <sup>b</sup>	Typ. <sup>c</sup>	Max. <sup>b</sup>	
<b>Dynamic</b>						
Propagation Delay - TX to $V_{DIFF}$ High	$t_{ON-\overline{TX}}$				50	ns
Propagation Delay - TX to $V_{DIFF}$ Low	$t_{OFF-\overline{TX}}$				50	
Propagation Delay - TX to Receive Low	$t_{ON-\overline{RX}}$				120	
Propagation Delay - TX to Receive High	$t_{OFF-\overline{RX}}$				120	
<b>Supply</b>						
Supply Current	$I_{DD}$	$\overline{TX} = V_{INH}, V_{DD} = 5.25\text{ V}, R_L = 60\ \Omega$ (Recessive)			25	mA
		$\overline{TX} = V_{INL}, V_{DD} = 5.25\text{ V}, R_L = 60\ \Omega$ (Dominant)	40		75	
<b>Transient<sup>c</sup></b>						
Electrostatic Discharge Human Body Model	$V_{ESD}$	$C_L = 100\text{ pF}, R_L = 1500\ \Omega$ MIL-STD-883D, Method 3015		2000		V
Bus Transient Voltage	$V_{TRANS}$	$R_S = 1000\ \Omega, 1\text{ ms}$	- 60		60	
<b>Protection</b>						
Thermal Trip Point <sup>c</sup>	$T_{TRP}$		150	165	180	°C
Thermal Hysteresis <sup>c</sup>	$T_{HYS}$		10	20	30	

Notes:

- a. Typical values are for DESIGN AID ONLY at  $T_A = 25\text{ °C}$ , not guaranteed nor subject to production testing.
- b. The algebraic convention whereby the most negative value is a minimum and the most positive a maximum.
- c. Guaranteed by design, not subject to production test.

Truth Table					
$\overline{TX}$	Mode	Bus State	CAN_H	CAN_L	RX
Low	Transmit	Dominant	High	Low	Low
High (or Floating)	Transmit and Receive	Recessive	Floating	Floating	High
High (or Floating)	Receive	Recessive	High	Low	Low

**SWITCHING TIME TEST CIRCUIT**

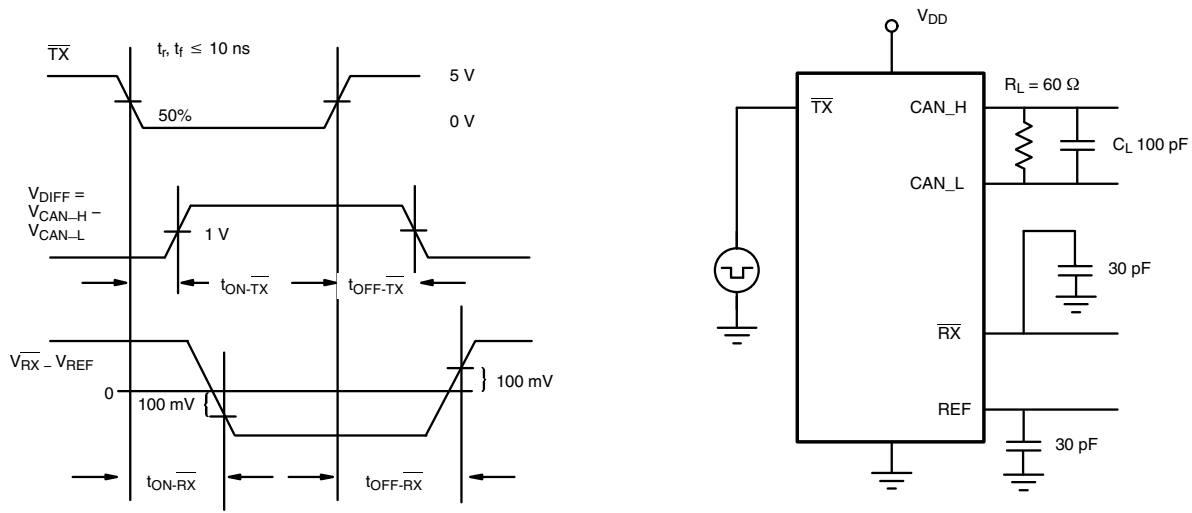

**CIRCUIT SCHEMATIC**

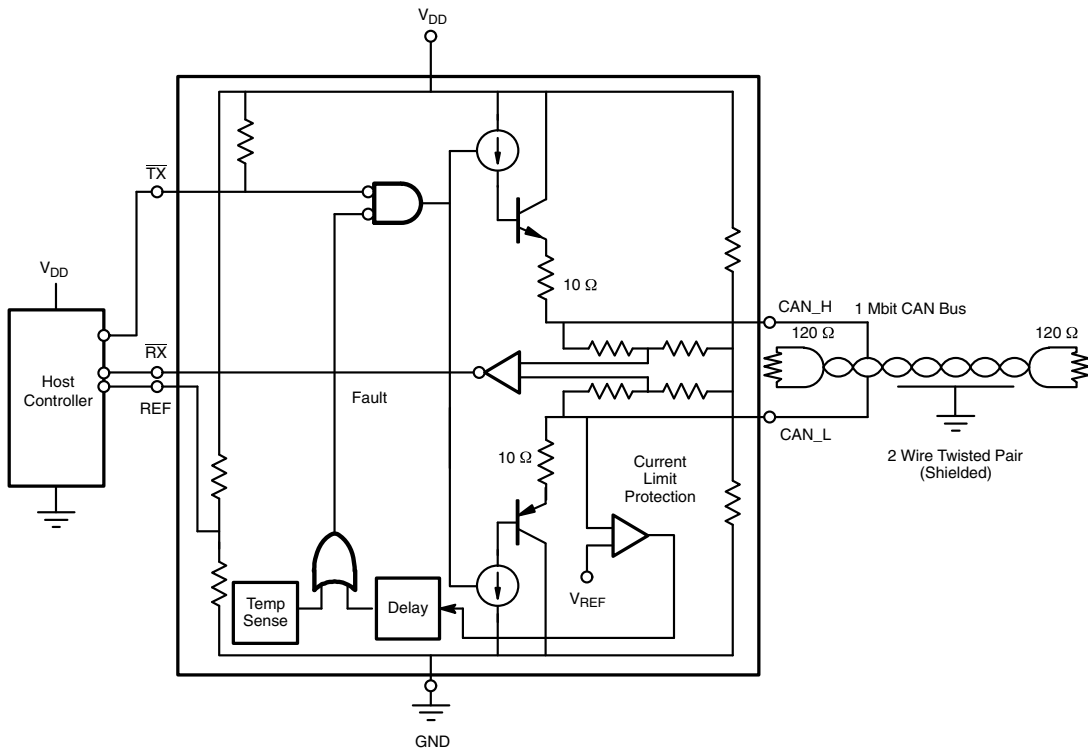

## SOIC (NARROW): 8-LEAD

JEDEC Part Number: MS-012



DIM	MILLIMETERS		INCHES	
	Min	Max	Min	Max
A	1.35	1.75	0.053	0.069
A <sub>1</sub>	0.10	0.20	0.004	0.008
B	0.35	0.51	0.014	0.020
C	0.19	0.25	0.0075	0.010
D	4.80	5.00	0.189	0.196
E	3.80	4.00	0.150	0.157
e	1.27 BSC		0.050 BSC	
H	5.80	6.20	0.228	0.244
h	0.25	0.50	0.010	0.020
L	0.50	0.93	0.020	0.037
q	0°	8°	0°	8°
S	0.44	0.64	0.018	0.026
ECN: C-06527-Rev. I, 11-Sep-06				
DWG: 5498				



## Disclaimer

ALL PRODUCT, PRODUCT SPECIFICATIONS AND DATA ARE SUBJECT TO CHANGE WITHOUT NOTICE TO IMPROVE RELIABILITY, FUNCTION OR DESIGN OR OTHERWISE.

Vishay Intertechnology, Inc., its affiliates, agents, and employees, and all persons acting on its or their behalf (collectively, "Vishay"), disclaim any and all liability for any errors, inaccuracies or incompleteness contained in any datasheet or in any other disclosure relating to any product.

Vishay makes no warranty, representation or guarantee regarding the suitability of the products for any particular purpose or the continuing production of any product. To the maximum extent permitted by applicable law, Vishay disclaims (i) any and all liability arising out of the application or use of any product, (ii) any and all liability, including without limitation special, consequential or incidental damages, and (iii) any and all implied warranties, including warranties of fitness for particular purpose, non-infringement and merchantability.

Statements regarding the suitability of products for certain types of applications are based on Vishay's knowledge of typical requirements that are often placed on Vishay products in generic applications. Such statements are not binding statements about the suitability of products for a particular application. It is the customer's responsibility to validate that a particular product with the properties described in the product specification is suitable for use in a particular application. Parameters provided in datasheets and / or specifications may vary in different applications and performance may vary over time. All operating parameters, including typical parameters, must be validated for each customer application by the customer's technical experts. Product specifications do not expand or otherwise modify Vishay's terms and conditions of purchase, including but not limited to the warranty expressed therein.

Hyperlinks included in this datasheet may direct users to third-party websites. These links are provided as a convenience and for informational purposes only. Inclusion of these hyperlinks does not constitute an endorsement or an approval by Vishay of any of the products, services or opinions of the corporation, organization or individual associated with the third-party website. Vishay disclaims any and all liability and bears no responsibility for the accuracy, legality or content of the third-party website or for that of subsequent links.

Except as expressly indicated in writing, Vishay products are not designed for use in medical, life-saving, or life-sustaining applications or for any other application in which the failure of the Vishay product could result in personal injury or death. Customers using or selling Vishay products not expressly indicated for use in such applications do so at their own risk. Please contact authorized Vishay personnel to obtain written terms and conditions regarding products designed for such applications.

No license, express or implied, by estoppel or otherwise, to any intellectual property rights is granted by this document or by any conduct of Vishay. Product names and markings noted herein may be trademarks of their respective owners.