

**SURFACE MOUNT  
FAST SWITCHING DIODE**

**REVERSE VOLTAGE – 80 Volts  
FORWARD CURRENT – 0.1 Ampere**

- FEATURES**
- Fast switching speed
  - Low reverse leakage current
- MECHANICAL DATA**
- Case: SOD-323 Plastic
  - Case material: “Green” molding compound, UL flammability classification 94V-0, (No Br. Sb. Cl)
  - Moisture sensitivity: Level 1 per J-STD-020D
  - Lead free in RoHS 2002/95/EC compliant

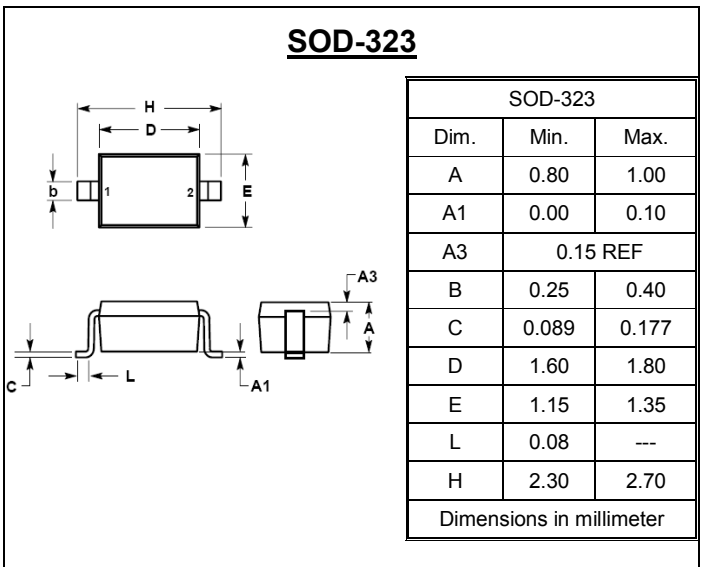

**Maximum Ratings & Thermal Characteristics @ T<sub>A</sub> = 25°C unless otherwise specified**

Characteristic	Symbol	1SS355	Units
Non-Repetitive Peak Reverse Voltage	V <sub>RM</sub>	90	V
DC Blocking Voltage	V <sub>R</sub>	80	V
Forward Continuous Current	I <sub>FM</sub>	225	mA
Average Rectified Output Current	I <sub>O</sub>	100	mA
Peak Forward Surge Current @t=1s	I <sub>FSM</sub>	0.5	A
Junction Temperature	T <sub>J</sub>	150	°C
Storage Temperature Range	T <sub>STG</sub>	-55~+150	°C

**Electrical Characteristics @ T<sub>A</sub> = 25°C unless otherwise specified**

Characteristic	Test Condition	Symbol	1SS355	Unit
Maximum Forward Voltage	I <sub>F</sub> = 100mA	V <sub>F</sub>	1.2	V
Maximum DC Reverse Current at Rated DC Blocking Voltage	V <sub>R</sub> = 80V	I <sub>R</sub>	0.1	uA
Typical Diode Capacitance	V <sub>R</sub> = 0V, f=1MHz	C <sub>D</sub>	3	pF
Reverse Recovery time	V <sub>R</sub> =6V, I <sub>R</sub> =I <sub>F</sub> =10mA R <sub>L</sub> =100Ω	trr	4	ns

REV. 3, Jul-2013, KSYR12

**Fig.1 Typical Forward Characteristics**

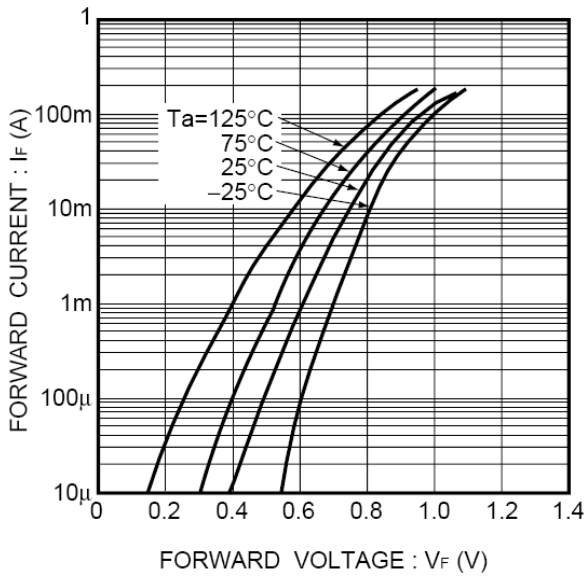

**Fig.2 Typical Reverse Characteristics**

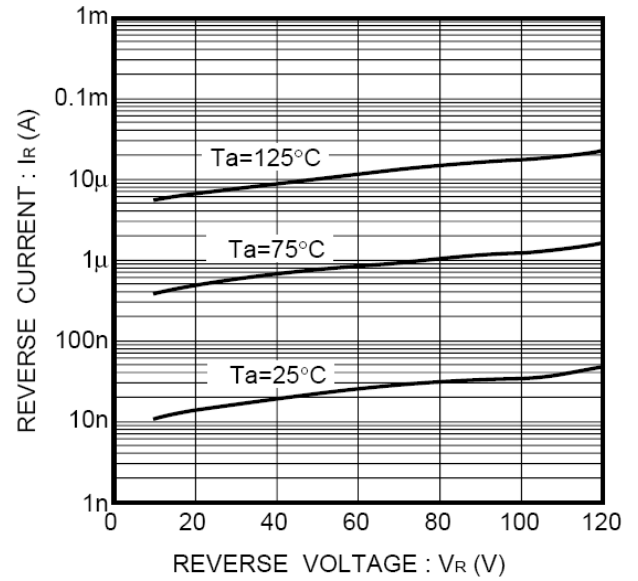

**Fig.3 Total Capacitance vs. Reverse Voltage**

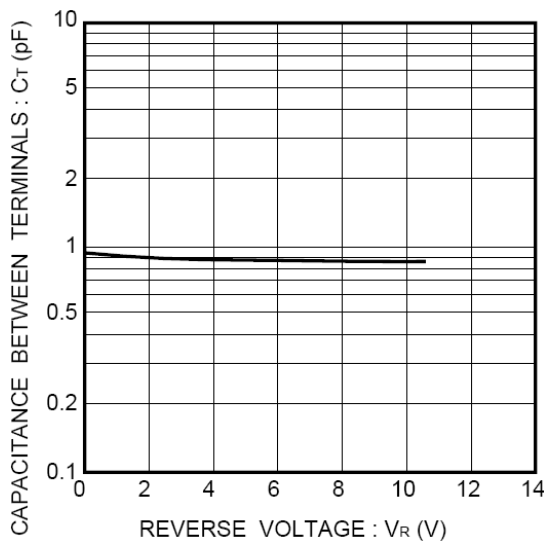

**Fig.4 Reverse Recovery Time vs. Forward Current**

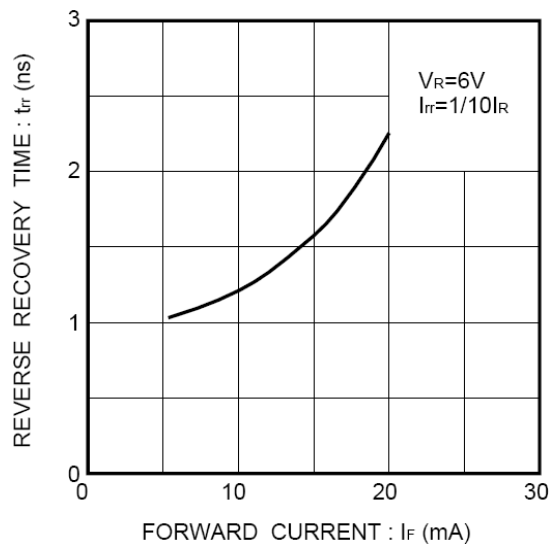

**Fig.5 Surge Current Characteristics**

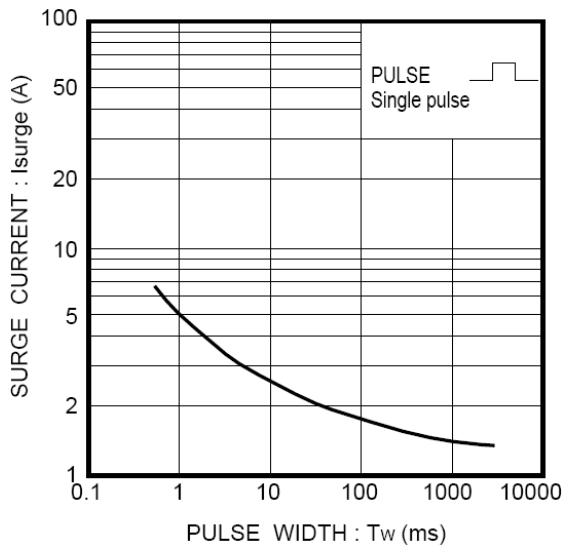

**Fig.6 Reverse recovery time ( $t_{rr}$ ) measurement circuit**

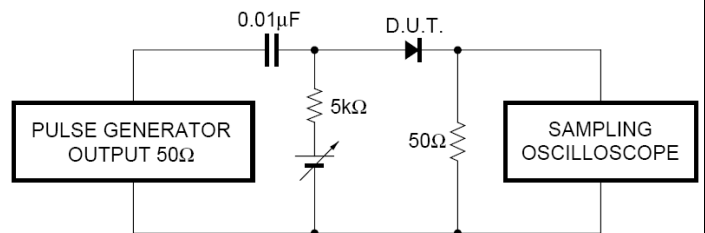

**Device Marking :**



Device P/N	Marking code	Equivalent Circuit Diagram
1SS355	5D	 The diagram shows a diode symbol with terminal 1 on the left and terminal 2 on the right. The arrow points from terminal 2 to terminal 1, indicating the direction of current flow.

## **Important Notice and Disclaimer**

LSC reserves the right to make changes to this document and its products and specifications at any time without notice. Customers should obtain and confirm the latest product information and specifications before final design, purchase or use.

LSC makes no warranty, representation or guarantee regarding the suitability of its products for any particular purpose, nor does LSC assume any liability for application assistance or customer product design. LSC does not warrant or accept any liability with products which are purchased or used for any unintended or unauthorized application.

No license is granted by implication or otherwise under any intellectual property rights of LSC.

LSC products are not authorized for use as critical components in life support devices or systems without express written approval of LSC.

## New Marking Rule Notification

Range: In order to have well management in process control, the new marking rule is applied to small signal device including Switching Diode, Transistor and Schottky Diode.

Package: SOD-123 / SOD-323 / SOD-523

