

PT7M6315US

Supervisory Circuit

Features

- Highly Accurate: $\pm 1.5\%$ (25°C)
- Detect Voltage Range: 1.8V to 5V in 100mV Increments
- Operating Voltage Range: 1.0V ~ 5.5V
- Operating Temperature Range: -40°C to + 85°C
- Detect Voltage Temperature Characteristics: $\pm 2.5\% \times \text{TYP}$
- Output Configuration: N-Channel Open Drain
- Totally Lead-Free & Fully RoHS Compliant (Notes 1 & 2)
- Halogen and Antimony Free. “Green” Device (Note 3)
- Three Reset Timeout Period Available:
 - ◆ Typical 1.6ms for PT7M6315USxxD1;
 - ◆ Typical 26ms for PT7M6315USxxD2;
 - ◆ Typical 200ms for PT7M6315USxxD3;
 - ◆ Typical 1570ms for PT7M6315USxxD4;

Description

The series is designed to monitor power supplies in μP and digital systems. It provides excellent circuit reliability and low cost by eliminating external components and adjustments, and a debounced manual reset input.

This device performs a single function: it asserts a reset signal whenever the V_{CC} supply voltage falls below a preset threshold or whenever manual reset is asserted. Reset remains asserted for an internally programmed interval (reset timeout period) after V_{CC} has risen above the reset threshold or manual reset is deasserted.

The PT7M6315USxx devices are open-drain RESET output. They can be pulled up to a voltage higher than V_{CC} .

The serials come with factory-trimmed, reset threshold voltages in 100mV increments from 1.8V to 5V. Preset timeout periods of 200ms (typ.) for PT7M6315USxxD3, 1570ms (typ.) for PT7M6315USxxD4, and 26ms for PT7M6315USxxD2 are available.

Pin Configuration

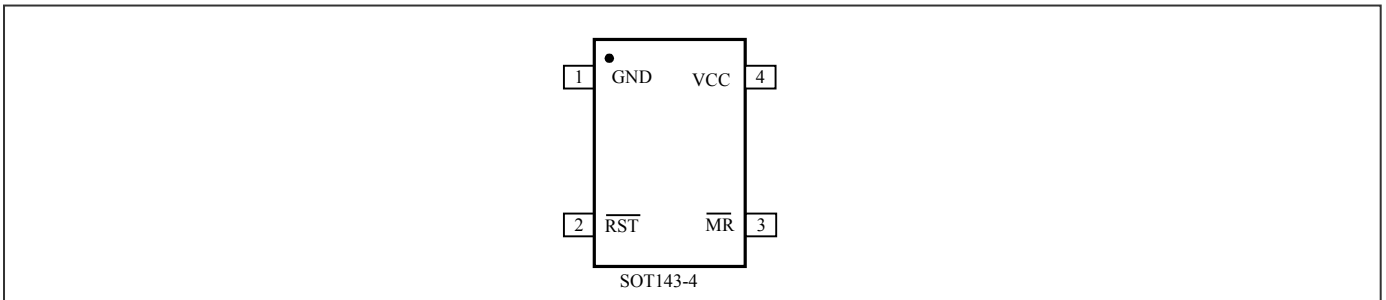

Pin Description

Name	Type	Description
$\overline{\text{RST}}$	I/O	Reset Output: $\overline{\text{RST}}$ is asserted when V_{CC} drops below voltage threshold V_{TH} . Active low.
$\overline{\text{MR}}$	I	Manual Reset: A logic low on $\overline{\text{MR}}$ asserts reset. Reset remains asserted as long as $\overline{\text{MR}}$ is low, and for the reset timeout period (t_{RS}) after the reset conditions are terminated. Connect to V_{CC} if not used.
GND	P	Ground
V_{CC}	P	Supply Voltage.

Notes:

1. No purposely added lead. Fully EU Directive 2002/95/EC (RoHS), 2011/65/EU (RoHS 2) & 2015/863/EU (RoHS 3) compliant.
2. See <https://www.diodes.com/quality/lead-free/> for more information about Diodes Incorporated's definitions of Halogen- and Antimony-free, "Green" and Lead-free.
3. Halogen- and Antimony-free "Green" products are defined as those which contain <900ppm bromine, <900ppm chlorine (<1500ppm total Br + Cl) and <1000ppm antimony compounds.

Block Diagram

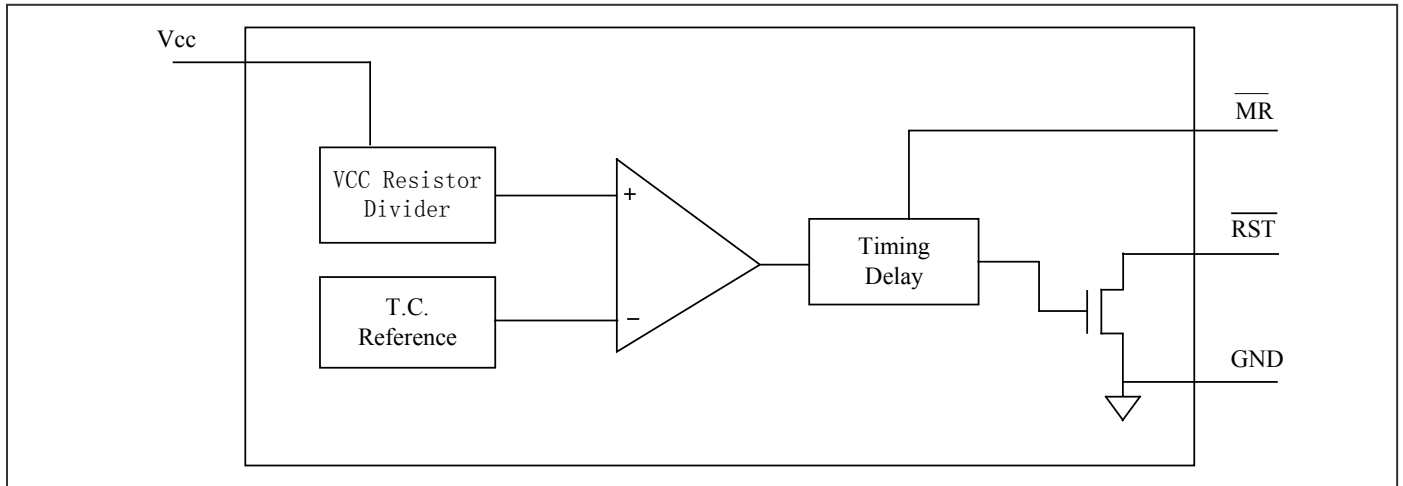

Function Description

Power Monitor

A microprocessor's (μP) reset input starts the μP in a known state. Whenever the μP is in an unknown state, it should be held in reset. The supervisory circuits assert reset during power-up and prevent code execution errors during power down or brownout conditions.

On power up, once V_{cc} reaches about 1.0V, $\overline{\text{RST}}$ is a guaranteed logic low of 0.4V or less. As V_{cc} rises, $\overline{\text{RST}}$ stays low. When V_{cc} rises above the reset threshold V_{RST} , an internal timer releases $\overline{\text{RST}}$ after about 200ms (PT7M6315USxxD3) or 1570ms (PT7M6315USxxD4) or 26ms (PT7M6315USxxD2) or 1.6ms (PT7M6315USxxD1). $\overline{\text{RST}}$ asserts whenever V_{cc} drops below the reset threshold, i.e. brownout condition. If brownout occurs in the middle of a previously initiated reset pulse, the pulse continues for at least another 200ms (PT7M6315USxxD3) or 1570ms (PT7M6315USxxD4) or 26ms (PT7M6315USxxD2) or 1.6ms (PT7M6315USxxD1). On power down, once V_{cc} falls below the reset threshold, $\overline{\text{RST}}$ stays low and is guaranteed to be 0.4V or less until V_{cc} drops below 1V.

Manual Reset

The manual-reset input ($\overline{\text{MR}}$) allows reset to be triggered by a push button switch. The switch is effectively debounced by the 1.6ms (PT7M6315USxxD1) or 26ms (PT7M6315USxxD2) or 200ms (PT7M6315USxxD3) or 1570ms (PT7M6315USxxD4) reset pulse width.

Maximum Ratings

Storage Temperature	-65°C to +150°C
Ambient Temperature with Power Applied	-40°C to +85°C
Supply Voltage to Ground Potential (V _{CC} to GND)	-0.3V to +7.0V
DC Input Voltage (All inputs except V _{CC} and GND).....	-0.3V to V _{CC} +0.3V
DC Output Current (All outputs)	30mA
Power Dissipation	320mW (Depends on package)

Note:

Stresses greater than those listed under MAXIMUM RATINGS may cause permanent damage to the device. This is a stress rating only and functional operation of the device at these or any other conditions above those indicated in the operational sections of this specification is not implied. Exposure to absolute maximum rating conditions for extended periods may affect reliability.

DC Electrical Characteristics

(T_A = -40~85°C, unless otherwise noted. Typical values are at T_A = +25°C)

Description		Sym.	Test Conditions	Min	Typ	Max	Unit
Supply Voltage		V _{CC}	—	1.0	—	5.5	V
Supply Current		I _{CC}	V _{CC} = 5.5V. No load.	—	—	12	μA
			V _{CC} = 3.6V. No load.	—	—	10	μA
Voltage Threshold		V _{TH-}	+25°C	(V _{TH-}) ×0.985	V _{TH-}	(V _{TH-}) ×1.015	V
			-40°C~85°C	(V _{TH-}) ×0.975	V _{TH-}	(V _{TH-}) ×1.025	—
Hysteresis		V _{HYS}	V _{TH+} - V _{TH-} *	—	50	—	mV
Output Driving	Output Low	V _{OL}	I _{OH} = 8mA, V _{CC} = 5V	—	—	0.4	V
			I _{OH} = 4mA, V _{CC} = 3V	—	—	0.3	
			I _{OH} = -50μA, V _{CC} = 1V	—	—	0.09	
Open-Drain Output Leakage Current		I _{LKG}	—	—	—	500	nA
Internal Pull-Up Resistor		R _P	\overline{MR}	32	63	100	kΩ
Input High Voltage		V _{IH}	\overline{MR}	V _{CC} < 4V	0.7×V _{CC}	—	V
				V _{CC} > 4V	2.4	—	
Input Low Voltage		V _{IL}	\overline{MR}	V _{CC} < 4V	—	0.3×V _{CC}	V
				V _{CC} > 4V	—	—	

Note: V_{TH-} is voltage threshold when V_{CC} falls from high to low. V_{TH+} is voltage threshold when V_{CC} rises from low to high.

AC Electrical Characteristics
Timing Diagram

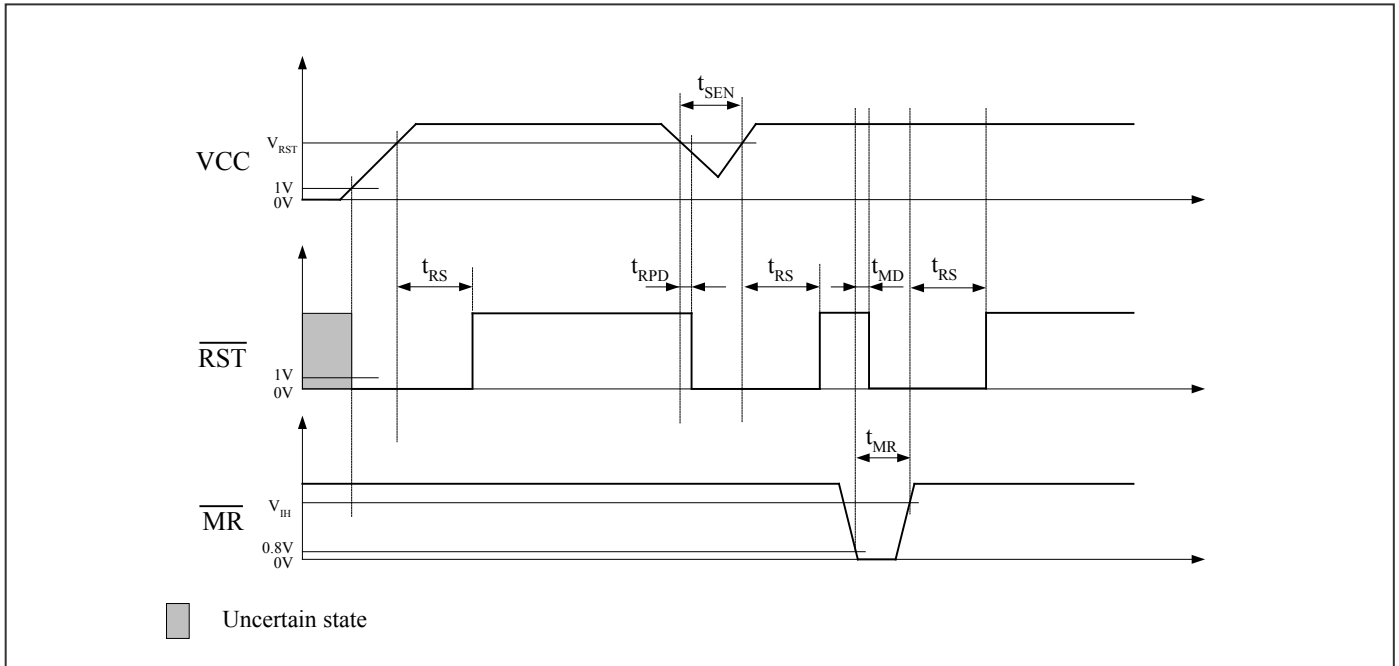

(V_{CC} = 1.0V to 5.5V, T_A = -40~85°C, unless otherwise noted. Typical values are at T_A = +25°C)

Sym.	Description	Test Conditions	Part No.	Min	Typ	Max	Unit
t _{RS}	Reset Timeout Period	—	6315USxxD1	1	1.6	2.2	ms
		—	6315USxxD2	17	26	40	ms
		—	6315USxxD3	140	200	280	ms
		—	6315USxxD4	1120	1570	2240	ms
t _{RPD}	Delay	—	—	17	—	μs	
t _{SEN}	Sensitivity	—	—	20	—	μs	
t _{MD}	\overline{MR} to Reset Delay	—	—	—	500	—	ns
t _{MR}	\overline{MR} Pulse Width	—	—	1	—	—	μs

Packaging Mechanical
4-SOT143 (TB)

PKG. DIMENSIONS(MM)		
SYMBOL	Min	Max
A	0.80	1.22
A1	0.00	0.15
A2	0.75	1.07
b	0.30	0.50
b1	0.75	0.90
c	0.08	0.20
D	2.80	3.04
d	0.20 BSC	
E	1.20	1.40
E1	2.10	2.64
e	1.92 BSC	
L	0.30	0.60
θ	0°	8°

Note:
1. Comply with TO-253D/AA, except A1 Min, b1 Min, b1 Max, and L Min.
2. PACKAGE OUTLINE DIMENSIONS DO NOT INCLUDE MOLD FLASH AND METAL BURR

		DATE: 03/29/16
DESCRIPTION: 4-Pin, SOT143		
PACKAGE CODE: TB (TB4)		
DOCUMENT CONTROL#: PD-2146	REVISION: A	

16-0083

For latest package information:

See <http://www.diodes.com/design/support/packaging/pericom-packaging/packaging-mechanicals-and-thermal-characteristics/>.

Ordering Information

Part Number	Package Code	Package Description
PT7M6315USxxD1TBEX	TB	4-pin (SOT143)
PT7M6315USxxD2TBEX	TB	4-pin (SOT143)
PT7M6315USxxD3TBEX	TB	4-pin (SOT143)
PT7M6315USxxD4TBEX	TB	4-pin (SOT143)

Notes:

- No purposely added lead. Fully EU Directive 2002/95/EC (RoHS), 2011/65/EU (RoHS 2) & 2015/863/EU (RoHS 3) compliant.
- See <http://www.diodes.com/quality/lead-free/> for more information about Diodes Incorporated's definitions of Halogen- and Antimony-free, "Green" and Lead-free.
- Thermal characteristics can be found on the company web site at www.diodes.com/design/support/packaging/
- E = Pb-free and Green
- X suffix = Tape/Reel

Table 1. Suffix “xx” definition of PT7M6315USxx

Suffix xx	V _{TH} (V)	Suffix xx	V _{TH} (V)	Suffix xx	V _{TH} (V)	Suffix xx	V _{TH} (V)
18	1.8	27	2.7	36	3.6	45	4.5
19	1.9	28	2.8	37	3.7	46	4.6
20	2.0	29	2.9	38	3.8	47	4.7
21	2.1	30	3.0	39	3.9	48	4.8
22	2.2	31	3.1	40	4.0	49	4.9
23	2.3	32	3.2	41	4.1	50	5.0
24	2.4	33	3.3	42	4.2	—	—
25	2.5	34	3.4	43	4.3	—	—
26	2.6	35	3.5	44	4.4	—	—

SOT-143 Package Top Marking Instruction

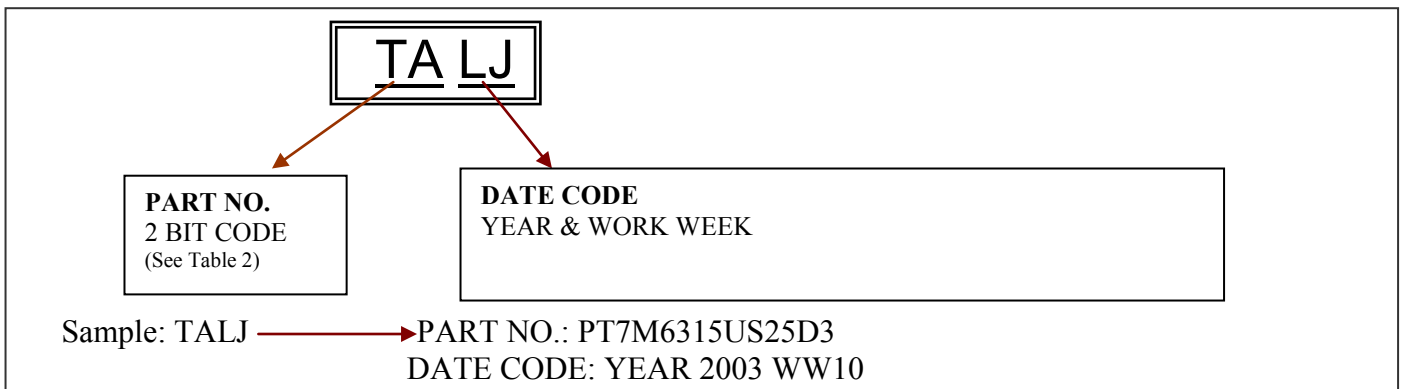

Table 2 Product Marking Code

Part No.	Code	Part No.	Code	Part No.	Code
PT7M6315US25D3	TA	PT7M6315US34D3	UK	PT7M6315US43D3	VU
PT7M6315US25D4	TB	PT7M6315US34D4	UL	PT7M6315US43D4	VV
PT7M6315US26D3	TE	PT7M6315US35D3	UO	PT7M6315US44D3	VY
PT7M6315US26D4	TF	PT7M6315US35D4	UP	PT7M6315US44D4	VZ
PT7M6315US27D3	TI	PT7M6315US36D3	US	PT7M6315US45D3	WC
PT7M6315US27D4	TJ	PT7M6315US36D4	UT	PT7M6315US45D4	WD
PT7M6315US28D3	TM	PT7M6315US37D3	UW	PT7M6315US46D3	WG
PT7M6315US28D4	TN	PT7M6315US37D4	UX	PT7M6315US46D4	WH
PT7M6315US29D3	TQ	PT7M6315US38D3	VA	PT7M6315US47D3	WK
PT7M6315US29D4	TR	PT7M6315US38D4	VB	PT7M6315US47D4	WL
PT7M6315US30D3	TU	PT7M6315US39D3	VE	PT7M6315US48D3	WO
PT7M6315US30D4	TV	PT7M6315US39D4	VF	PT7M6315US48D4	WP
PT7M6315US31D3	TY	PT7M6315US40D3	VI	PT7M6315US49D3	WS
PT7M6315US31D4	TZ	PT7M6315US40D4	VJ	PT7M6315US49D4	WT
PT7M6315US32D3	UC	PT7M6315US41D3	VM	PT7M6315US50D3	WW
PT7M6315US32D4	UD	PT7M6315US41D4	VN	PT7M6315US50D4	WX
PT7M6315US33D3	UG	PT7M6315US42D3	VQ	PT7M6315US29D2	pM
PT7M6315US33D4	UH	PT7M6315US42D4	VR	PT7M6315US30D2	pN

IMPORTANT NOTICE

DIODES INCORPORATED MAKES NO WARRANTY OF ANY KIND, EXPRESS OR IMPLIED, WITH REGARDS TO THIS DOCUMENT, INCLUDING, BUT NOT LIMITED TO, THE IMPLIED WARRANTIES OF MERCHANTABILITY AND FITNESS FOR A PARTICULAR PURPOSE (AND THEIR EQUIVALENTS UNDER THE LAWS OF ANY JURISDICTION).

Diodes Incorporated and its subsidiaries reserve the right to make modifications, enhancements, improvements, corrections or other changes without further notice to this document and any product described herein. Diodes Incorporated does not assume any liability arising out of the application or use of this document or any product described herein; neither does Diodes Incorporated convey any license under its patent or trademark rights, nor the rights of others. Any Customer or user of this document or products described herein in such applications shall assume all risks of such use and will agree to hold Diodes Incorporated and all the companies whose products are represented on Diodes Incorporated website, harmless against all damages.

Diodes Incorporated does not warrant or accept any liability whatsoever in respect of any products purchased through unauthorized sales channel.

Should Customers purchase or use Diodes Incorporated products for any unintended or unauthorized application, Customers shall indemnify and hold Diodes Incorporated and its representatives harmless against all claims, damages, expenses, and attorney fees arising out of, directly or indirectly, any claim of personal injury or death associated with such unintended or unauthorized application.

Products described herein may be covered by one or more United States, international or foreign patents pending. Product names and markings noted herein may also be covered by one or more United States, international or foreign trademarks.

This document is written in English but may be translated into multiple languages for reference. Only the English version of this document is the final and determinative format released by Diodes Incorporated.

LIFE SUPPORT

Diodes Incorporated products are specifically not authorized for use as critical components in life support devices or systems without the express written approval of the Chief Executive Officer of Diodes Incorporated. As used herein:

- A. Life support devices or systems are devices or systems which:
 - 1. are intended to implant into the body, or
 - 2. support or sustain life and whose failure to perform when properly used in accordance with instructions for use provided in the labeling can be reasonably expected to result in significant injury to the user.
- B. A critical component is any component in a life support device or system whose failure to perform can be reasonably expected to cause the failure of the life support device or to affect its safety or effectiveness.

Customers represent that they have all necessary expertise in the safety and regulatory ramifications of their life support devices or systems, and acknowledge and agree that they are solely responsible for all legal, regulatory and safety-related requirements concerning their products and any use of Diodes Incorporated products in such safety-critical, life support devices or systems, notwithstanding any devices- or systems-related information or support that may be provided by Diodes Incorporated. Further, Customers must fully indemnify Diodes Incorporated and its representatives against any damages arising out of the use of Diodes Incorporated products in such safety-critical, life support devices or systems.

Copyright © 2019, Diodes Incorporated
www.diodes.com