

SPECIFICATION FOR APPROVAL

CUSTOMER	
NOMINAL FREQUENCY	32.768 KHz
PRODUCT TYPE	TYPE G1 TUNING FORK X'TAL
SPEC. NO. (P/N)	G13270009
CUSTOMER P/N	
ISSUE DATE	Jun.24,2011
VERSION	A

APPROVED	PREPARED	QA
<i>Brenda</i>	<i>Clair</i>	<i>Tsai</i>
APPROVED BY CUSTOMER :		AVL Status
Please return one copy with approval to PSE-TW		

PSE Technology Corporation

No.2, Tzu-Chiang 5th Rd, Chung Li Industrial Park,
 Chung Li City, Taoyuan County, Taiwan (R.O.C.)
 TEL: 886-3-451-8888
 FAX: 886-3-461-3865
<http://www.saronix-ecera.com.tw>

- *RoHS Exception
- *HF-Halogen Free
- *REACH Compliant

TYPE G1 TUNING FORK X'TAL

G13270009

VER. A 24-Jun-11

VERSION HISTORY

Version No.	Version Date	Customer Receipt Date	Supplier Receipt Date	Description	Notes
A	Jun.24,2011			Initial Release	



TYPE G1 TUNING FORK X'TAL

G13270009

VER. A 24-Jun-11

ELECTRICAL SPECIFICATIONS

SRe Part Number : G13270009

Parameters	Symbol	Specifications	Units	Notes
Nominal Frequency	Fn	32.768	KHz	
Mode of Oscillation	MO	Fundamental		+2° X-Cut
Load Capacitance	CL	12.5	pF	Typical
Calibration Tolerance		± 20	ppm	at 25°C ± 5°C
Operating Temperature Range	TR	-40~85	°C	
Drive Level	DL	1	μW	Max.
Equivalent Series Resistance	ESR	35	KΩ	Max.
Shunt Capacitance C0	C0	1.6	pF	Typical
Temperature Coefficient	K	-0.035	ppm/°C ²	Typical
Aging		± 3	ppm	Max 1st year
Insulation Resistance		500	MΩ	at DC 100V ± 15V

Reliability (Mechanical and Environmental Endurance)

No.	Test Items	Test Method and Condition	Requirements
1	Vibration	(1) Vibration Frequency: 10 to 55Hz (2) Vibration Amplitude: 1.5mm (3) Cycle Time: 1-2min(10-55-10Hz) (4) Direction: X.Y.Z (5) Duration: 2h/each direction	Frequency Change: ±10ppm Max. Resistance Change: 5kohm Max.
2	Shock	3 Times free drop from 75cm height to hard wooden board of thickness more than 30mm	Frequency Change: ±10ppm Max. Resistance Change: 5kohm Max.
3	Leakage	Put crystal units into a hermetic container and Helium for 0.5-0.6Mpa, and keep it for 1h; Check the leakage by a Helium leak detector	Leakage: 1×10^{-8} Pa·m ³ /s Max.

TYPE G1 TUNING FORK X'TAL

G13270009

VER. A 24-Jun-11

4	Lead Strength (DIP)	The crystal lead with the 0.9kg(9N) power (keep it for 30s±5s) and bend the crystal lead 90° with 0.45kg power and two times (which you want to bend should be more than 1.5mm from the case)	The crystal lead is not abnormality
5	High Temperature Endurance	The crystal units shall be put in somewhere for 2 hrs at temperature of 85°C±2°C, then keep it for 1 to 2 hrs under room temperature.	Frequency Change: ±10ppm Max. Resistance Change: 5kohm Max.
6	Low Temperature Endurance	The crystal units shall be put in somewhere for 2 hrs at temperature of -25°C, then keep it for 1 to 2 hrs under room temperature.	
7	Humidity Endurance	The crystal units shall be put in somewhere at 40°C in relative humidity of 90-95% for 48 hrs, then keep it for one or two hours under room temperature.	
8	Temperature Cycle	Temperature shift from low(-40°C) to high(100°C, keep 30 mins), satisfy high(100°C) to low(-40°C, keep 30 mins), then go up to room temperature for 5 cycles.	
9	Salt Spray Test	Put the crystal units in the salt spray room (salt density: 5%) at the temperature of 35°C for 96 hrs. Then clean it with water and dry its surface.	The appearance shall has no abnormality and soldering is good. Frequency Change: ±10ppm Max. Resistance Change: 5kohm Max.



TYPE G1 TUNING FORK X'TAL

G13270009

VER. A 24-Jun-11

MARKING

32768

DIMENSIONS (Unit:mm)

L1	8.0±0.2
L2	9.6±0.5
D1	φ 3.0±0.1
D2	φ 3.0±0.1
D3	φ 0.32±0.05
B	0.8±0.2

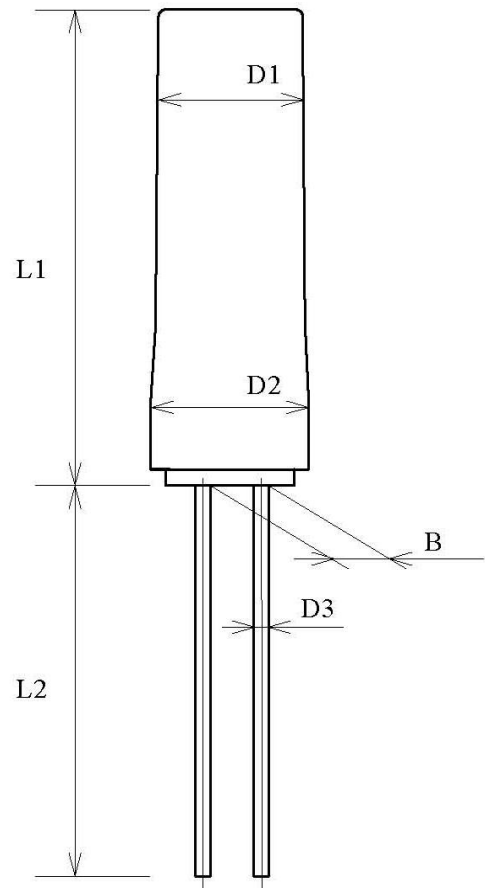

TYPE G1 TUNING FORK X'TAL

G13270009

VER. A 24-Jun-11

PACKING

