

Features:

- Near-Zero propagation delay
- 5-ohm switches connect inputs to outputs
- Direct bus connection when switches are ON
- Ultra-low quiescent power (0.2 μ A typical) – Ideally suited for notebook applications
- Pin compatible with 74 series 16245
- Industrial operating temperature: -40°C to $+85^{\circ}\text{C}$
- Packages (Pb-free & Green available):
 - 48-pin 240-mil wide thin plastic TSSOP (A)
 - 48-pin 150-mil wide plastic BQSOP (B)
 - 48-pin 300-mil wide plastic SSOP (V)

Description:

Pericom Semiconductor’s PI5C16245 and PI5C162245 are 16-bit, 2-port bus switches that are pin compatible with the 74 series 16245 16-bit transceiver. Two enable signals ($\overline{\text{nBE}}$) turn the switches on similar to the enable signals of the 16245. The bus switch creates no additional propagation delay or additional ground bounce noise.

The PI5C162245 device has a built-in 25-ohm series resistor to reduce noise due to reflections, thus eliminating the need for an external terminating resistor.

Block Diagram

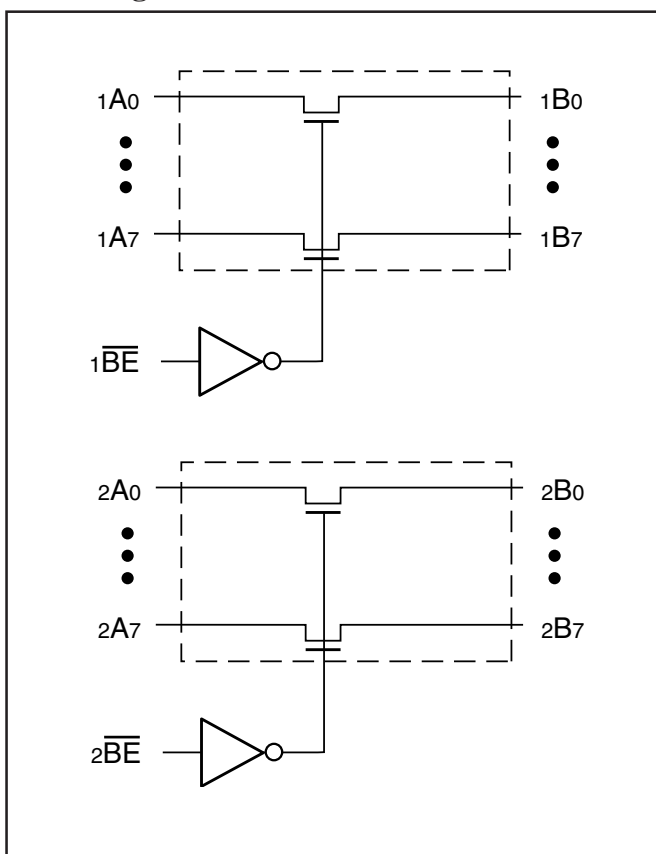

Pin Configuration

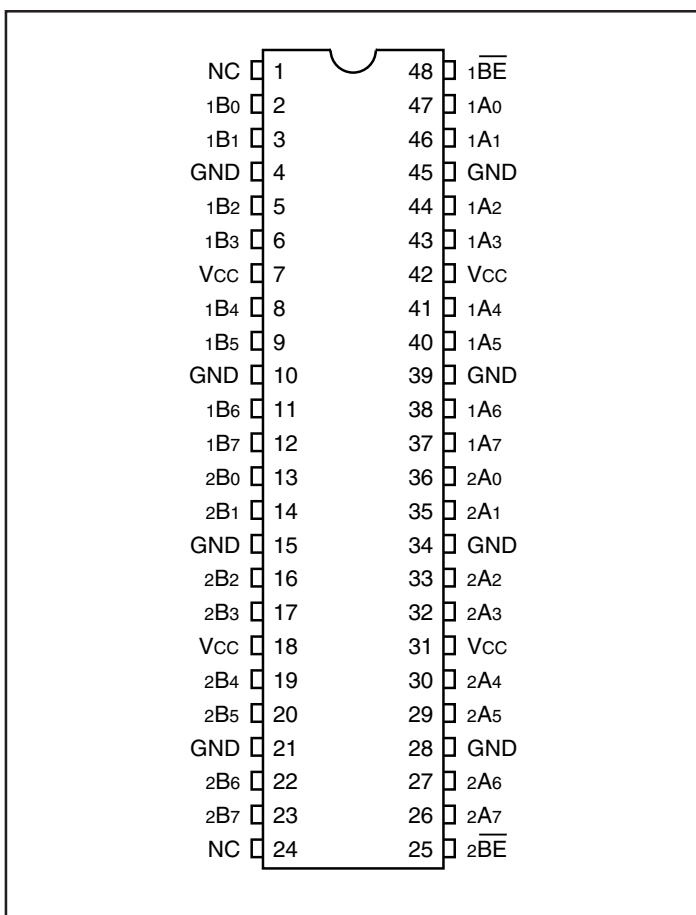

Truth Table⁽¹⁾

Function	$\overline{\text{nBE}}$	nA0-7
Disconnect	H	Hi-Z
Connect	L	nB0-7

Note: 1. H = High Voltage Level
 L = Low Voltage Level
 Hi-Z = High Impedance

Pin Description

Pin Name	I/O	Description
$\overline{\text{nBE}}$	I	Bus Enable Input (Active LOW)
nA0-nA7	I/O	Bus A
nB0-nB7	I/O	Bus B

Maximum Ratings

(Above which the useful life may be impaired. For user guidelines, not tested.)

Storage Temperature	-55°C to +125°C
Ambient Temperature with Power Applied	-40°C to +85°C
Supply Voltage to Ground Potential	-0.5V to +7.0V
DC Input Voltage	-0.5V to +7.0V
DC Output Current	120mA
Power Dissipation	0.5W

Note: Stresses greater than those listed under MAXIMUM RATINGS may cause permanent damage to the device. This is a stress rating only and functional operation of the device at these or any other conditions above those indicated in the operational sections of this specification is not implied. Exposure to absolute maximum rating conditions for extended periods may affect reliability.

DC Electrical Characteristics (Over the Operating Range, $T_A = -40^\circ\text{C}$ to $+85^\circ\text{C}$, $V_{CC} = 5\text{V} \pm 10\%$)

Parameters	Description	Test Conditions ⁽¹⁾	Min.	Typ ⁽²⁾	Max.	Units
V _{IH}	Input HIGH Voltage	Guaranteed Logic HIGH Level	2.0			V
V _{IL}	Input LOW Voltage	Guaranteed Logic LOW Level	-0.5		0.8	V
I _{IH}	Input HIGH Current	V _{CC} = Max., V _{IN} = V _{CC}			±1	µA
I _{IL}	Input LOW Current	V _{CC} = Max., V _{IN} = GND			±1	µA
I _{OZH}	High Impedance Output Current	0 ≤ A, B ≤ V _{CC}			±1	µA
V _{IK}	Clamp Diode Voltage	V _{CC} = Min., I _{IN} = -18 mA		-0.7	-1.2	V
I _{OS}	Short Circuit Current ⁽³⁾	A (B) = 0V, B (A) = V _{CC}	100			mA
V _H	Input Hysteresis at Control Pins			150		nV
R _{ON}	Switch On Resistance ⁽⁴⁾	V _{CC} = Min., V _{IN} = 0.0V, I _{ON} = 48 mA	16245	5	7	ohm
			162245	20	28	
		V _{CC} = Min., V _{IN} = 2.4V, I _{ON} = 15 mA	16245	10	15	ohm
			162245	20	35	

Capacitance ($T_A = 25^\circ\text{C}$, $f = 1\text{ MHz}$)

Parameters ⁽⁵⁾	Description	Test Conditions	Typ.	Max.	Units
C _{IN}	Input Capacitance	V _{IN} = 0V	6		pF
C _{OFF}	A/B Capacitance, Switch Off	V _{IN} = 0V	6		pF
C _{ON}	A/B Capacitance, Switch On	V _{IN} = 0V	9		pF

Notes:

- For Max. or Min. conditions, use appropriate value specified under Electrical Characteristics for the applicable device type.
- Typical values are at V_{CC} = 5.0V, T_A = 25°C ambient and maximum loading.
- Not more than one output should be shorted at one time. Duration of the test should not exceed one second.
- Measured by the voltage drop between A and B pin at indicated current through the switch. On-Resistance is determined by the lower of the voltages on the two (A,B) pins.
- This parameter is determined by device characterization but is not production tested.

Power Supply Characteristics

Parameters	Description	Test Conditions ⁽¹⁾		Min.	Typ ⁽²⁾	Max.	Units
I _{CC}	Quiescent Power Supply Current	V _{CC} =Max.	V _{IN} =GND or V _{CC}		0.1	3.0	μA
ΔI _{CC}	Supply Current per Input @ TTL HIGH	V _{CC} =Max.	V _{IN} =3.4V ⁽³⁾			2.5	mA
I _{CCD}	Supply Current per Input per MHz ⁽⁴⁾	V _{CC} =Max., A and B Pins Open nBE=GND Control Input Toggling 50% Duty Cycle				0.25	mA/ MHz

Notes:

- For Max. or Min. conditions, use appropriate value specified under Electrical Characteristics for the applicable device.
- Typical values are at V_{CC} = 5.0V, +25°C ambient.
- Per TTL driven input (V_{IN} = 3.4V, control inputs only); A and B pins do not contribute to I_{CC}.
- This current applies to the control inputs only and represent the current required to switch internal capacitance at the specified frequency. The A and B inputs generate no significant AC or DC currents as they transition. This parameter is not tested, but is guaranteed by design.

PI5C16245 Switching Characteristics over Operating Range

Parameters	Description	Conditions ⁽¹⁾	PI5C16245		Unit	
			Com.			
			Min	Max		
t _{PLH} t _{PHL}	Propagation Delay ^(2,3) xAx to xBx, xBx to xAx	C _L = 50 pF R _L = 500-ohm		0.25	ns	
t _{PZH} t _{PZL}	Bus Enable Time xBE to xAx or xBx		1.5	6.5		ns
t _{PHZ} t _{PLZ}	Bus Disable Time xBE to xAx or xBx		1.5	5.5		

PI5C162245 Switching Characteristics over Operating Range

Parameters	Description	Conditions ⁽¹⁾	PI5C162245		Unit	
			Com.			
			Min	Max		
t _{plh} t _{phl}	Propagation Delay ^(2,3) xAx to xBx, xBx to xAx	C _L = 50 pF R _L = 500-ohm		1.25	ns	
t _{pzh} t _{pzl}	Bus Enable Time xBE to xAx or xBx		1.5	6.5		ns
t _{phz} t _{plz}	Bus Disable Time xBE to xAx or xBx		1.5	5.5		

Notes:

- See test circuit and wave forms.
- This parameter is guaranteed but not tested on Propagation Delays.
- The bus switch contributes no propagational delay other than the RC delay of the On-Resistance of the switch and the load capacitance. The time constant for the switch alone is of the order of 0.25 ns for 50 pF load. Since this time constant is much smaller than the rise/fall times of typical driving signals, it adds very little propagational delay to the system. Propagational delay of the bus switch when used in a system is determined by the driving circuit on the driving side of the switch and its interaction with the load on the driven side.

Test Circuits

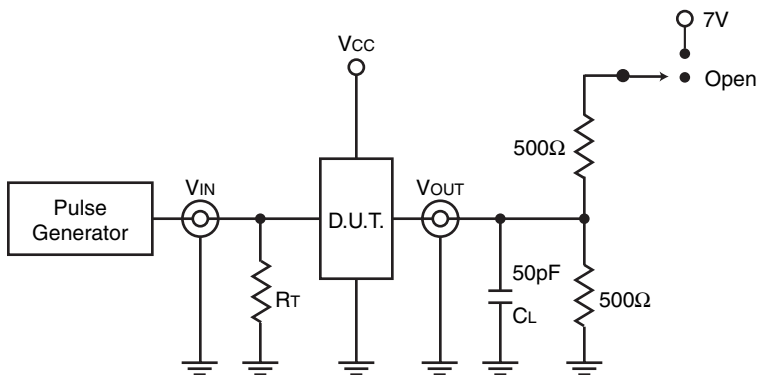

Switch Position

Test	Switch
Disable LOW	Closed
Enable LOW	Closed
t_{PD}	Open

Definitions:

C_L = Load capacitance (includes jig and probe capacitance)

R_T = Termination resistance (should be equal to Z_{OUT} of the pulse generator)

Enable and Disable Timing

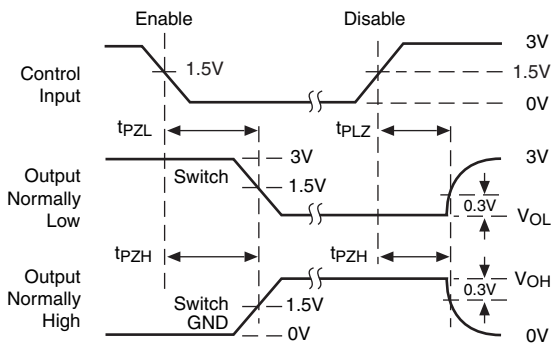

1. Input Control Enable = Low; Input Control Disable = High
2. Pulse Generator for all pulses:
Rate ≤ 1.0 MHz; $Z_{OUT} \leq 50\Omega$; $t_f, t_r \leq 2.5$ ns

Propagation Delay

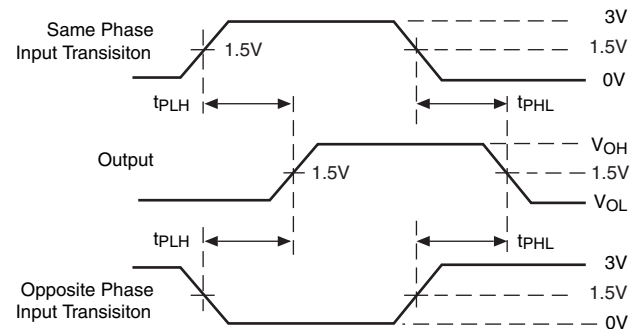

Packaging Mechanical: 48-pin TSSOP (A)

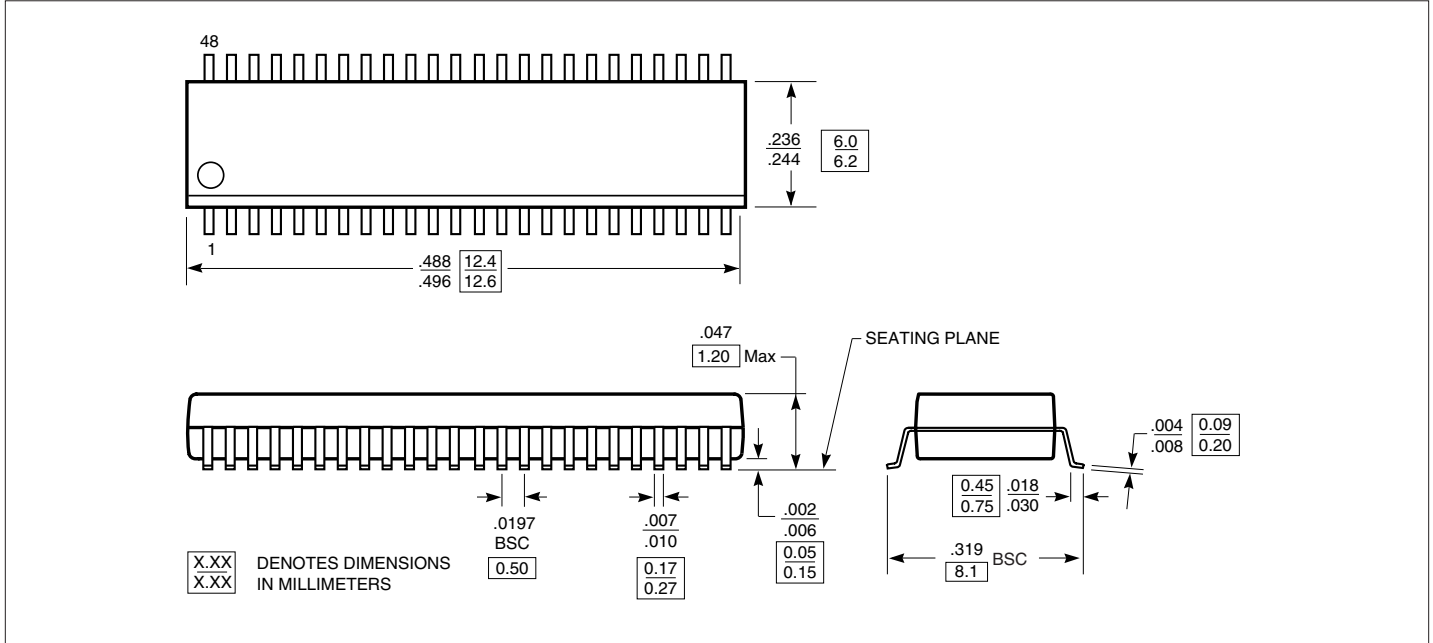

Packaging Mechanical: 48-pin SSOP (V)

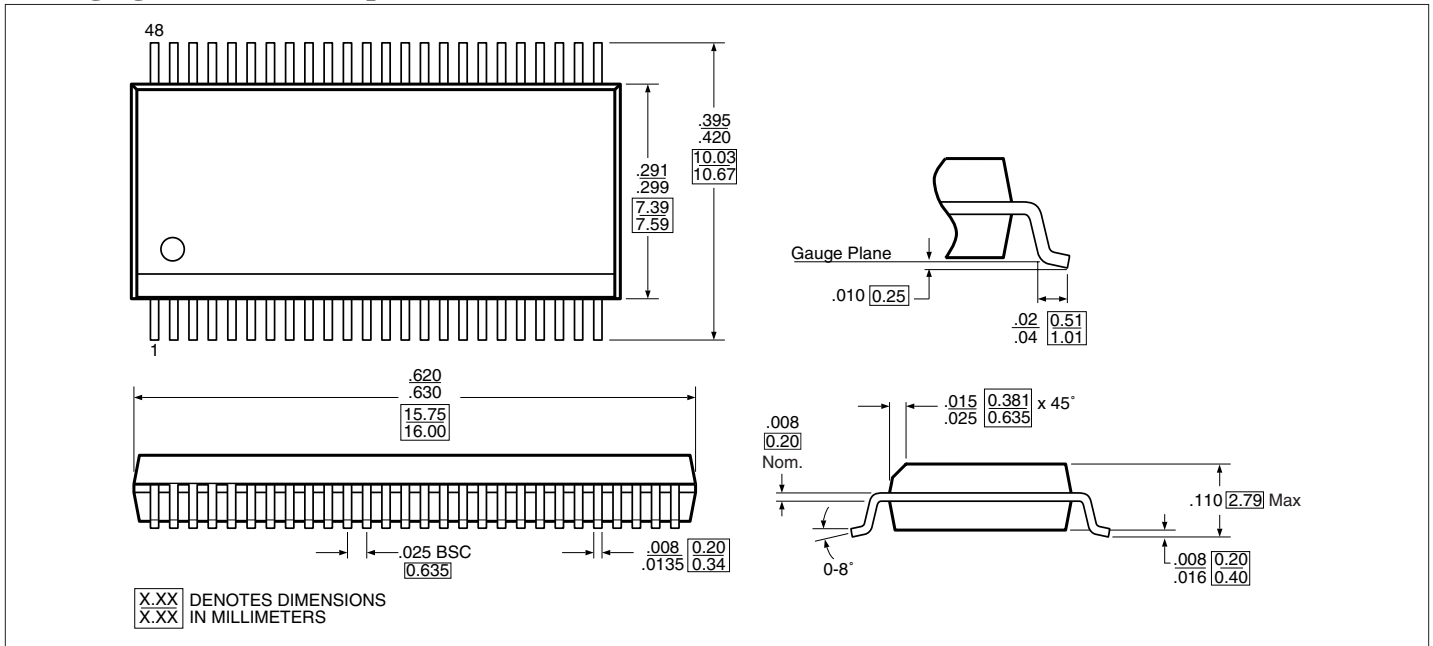

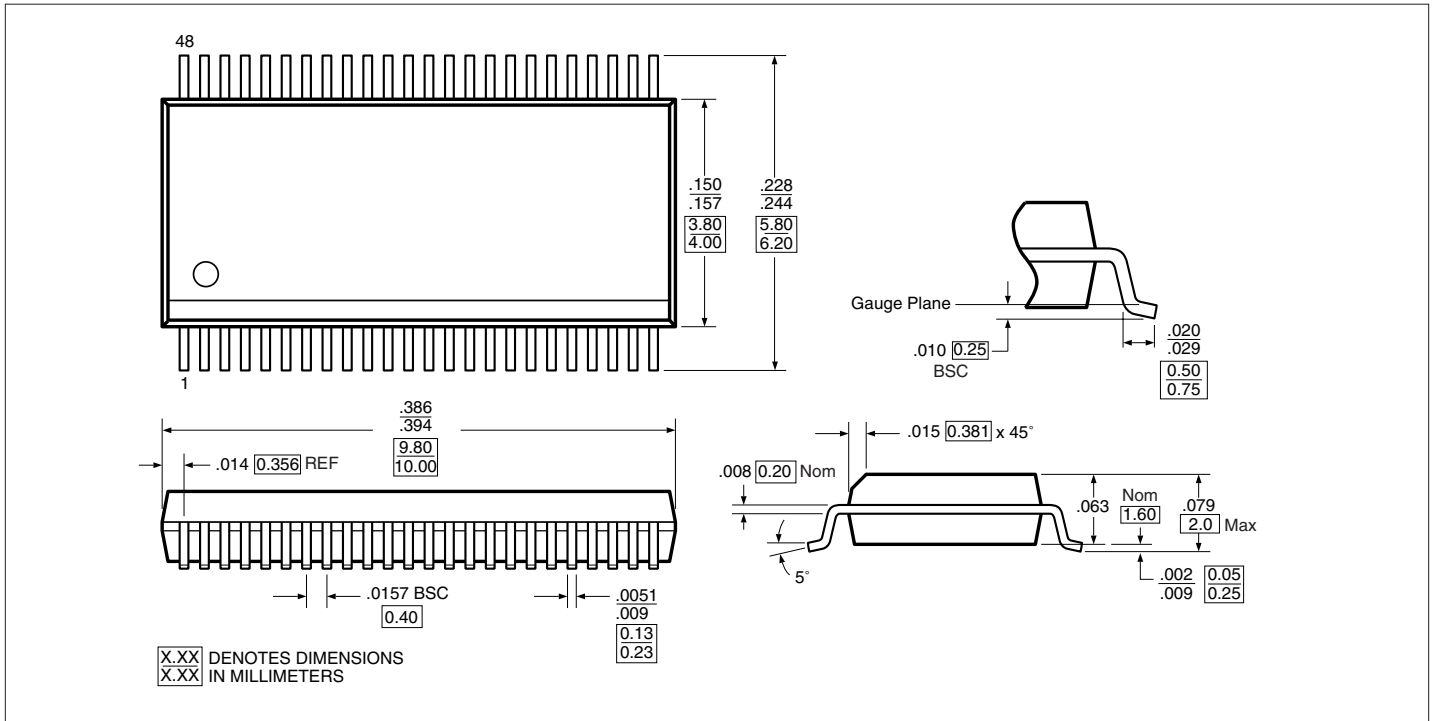
Packaging Mechanical: 48-pin BQSOP (B)

Ordering Information

Ordering Code	Package Code	Package Type
PI5C16245A	A	48-pin TSSOP
PI5C16245AE	A	Pb-free & Green, 48-pin TSSOP
PI5C16245V	V	48-pin BQSOP
PI5C16245VE	V	Pb-free & Green, 48-pin BQSOP
PI5C16245B	B	48-pin SSOP
PI5C16245BE	B	Pb-free & Green, 48-pin SSOP
PI5C162245A	A	48-pin TSSOP
PI5C162245AE	A	Pb-free & Green, 48-pin TSSOP
PI5C162245V	V	48-pin BQSOP
PI5C162245VE	V	Pb-free & Green, 48-pin BQSOP
PI5C162245B	B	48-pin SSOP
PI5C162245BE	B	Pb-free & Green, 48-pin SSOP

Notes:

- Thermal characteristics can be found on the company web site at www.pericom.com/packaging/
- E = Pb-free and Green
- X suffix = Tape/Reel