



PI3HDX511E

Ultra-Low Power HDMI1.4b Redriver/DP Level Shifter

Features

- Ultra-Low power HDMI 1.4b compliant Redriver with dual-mode DisplayPort Level Shifter
- Operation up to 3.4 Gbps per lane
- Max 4K resolution (4096x2160 at 30fps), 48-bit per pixel Deep Color supports
- Standby current typical 2uA
- Flexible three steps equalization control (2.5, 5, 7.5 dB) and Pre-emphasis control 3 steps (0, 1.5, 2.5 dB)
- Automatic output squelch and HPD detection for power saving states management
- DC coupled or AC coupled differential inputs
- Integrated DDC level shifter
- Single power supply: 3.3V
- Integrated ESD protection on I/O pins. 8kV contact and 8kV HBM
- Package: 32-pin TQFN(ZLS32, 3x6mm)
- Pin-to-pin compatible with PI3HDMI511 and PI3HDX511A

Description

PI3HDX511E is a HDMI 1.4b redriver and dual mode DisplayPort Level Shifter up to 3.4Gbps data rate with 48-bpp Deep Color, pin-compatible with PI3HDX511A product. This device is ideal solution to extend system's battery operation hours with typical 2uA standby and 80mA power supply current, comparing to the Retimer device.

The Redriver amplifies and reshapes AC and DC coupled input signals to the HDMI1.4b compliant signals at the HDMI or dual-mode DisplayPort source side systems. Programmable input equalization helps to solve the compliance jitter issues, creating in the non-standard HDMI source system with robust ESD/EOS protection of 8kV.

Application

- Notebook and Desktop computers
- Video streaming devices
- A/V receivers, Switch boxes and Dongle

Application Diagram

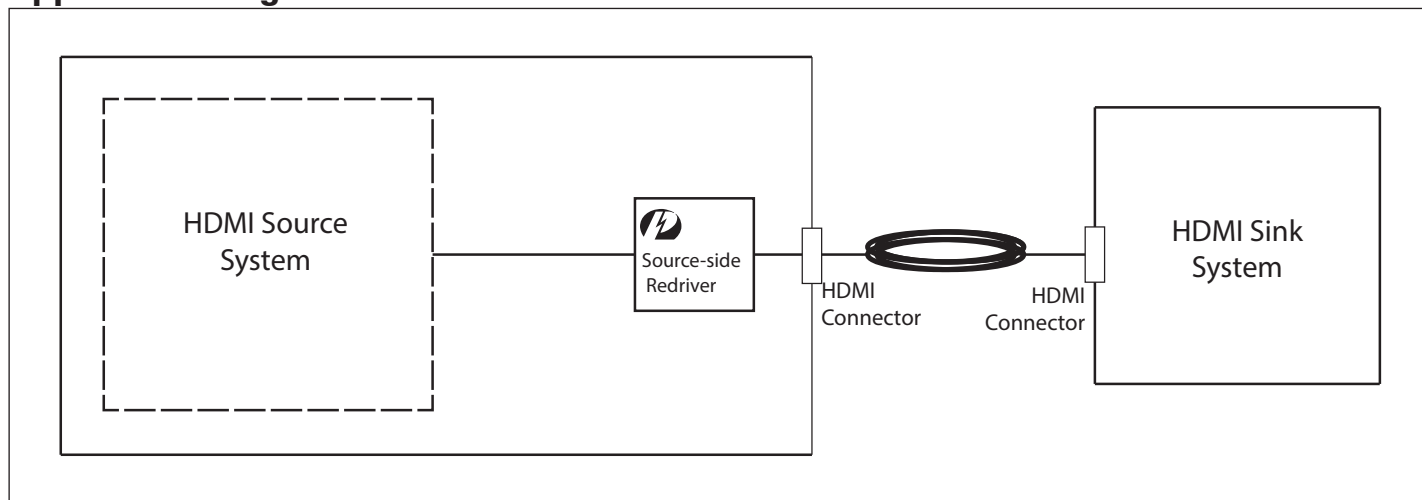

Block Diagram

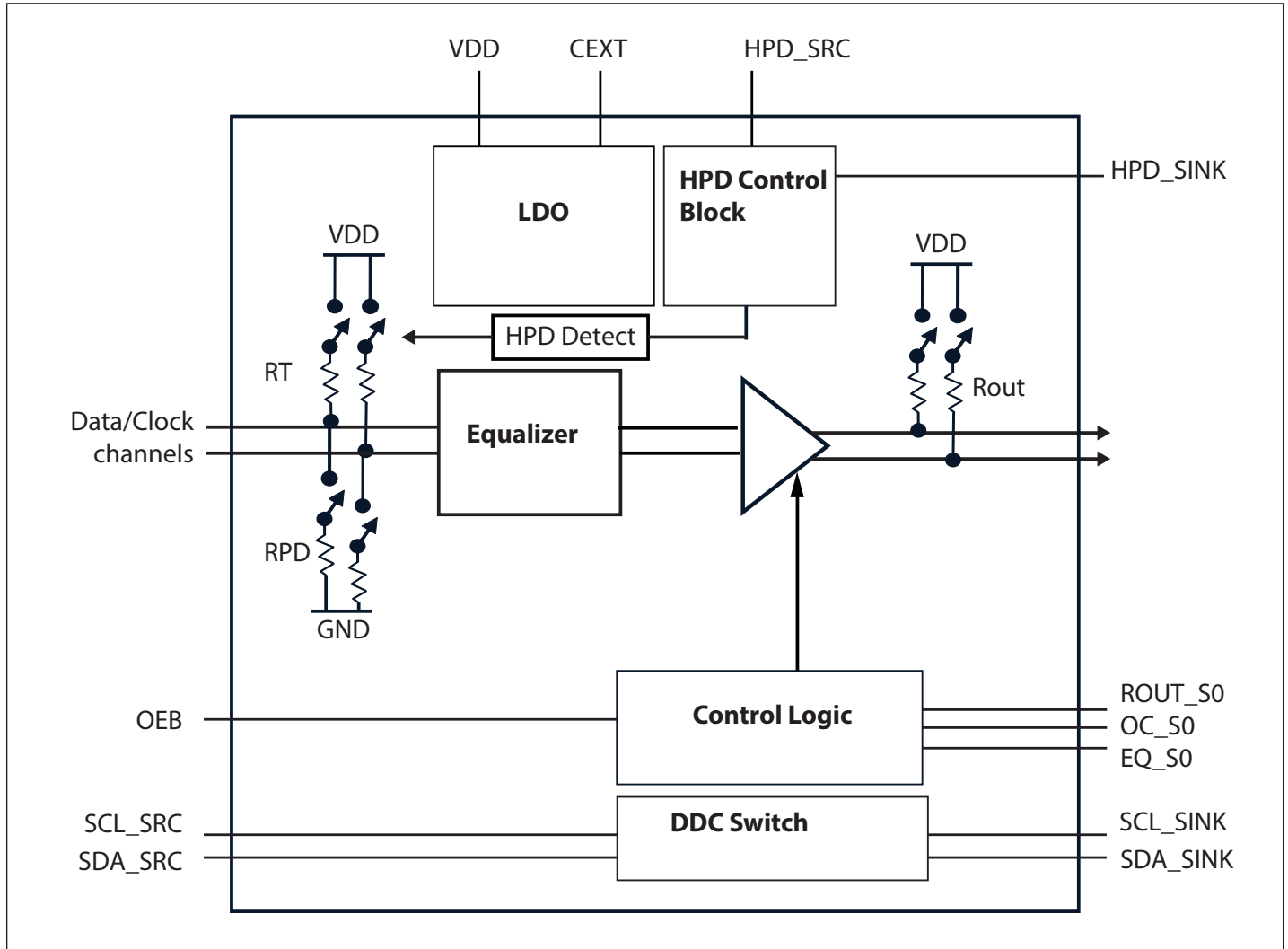

PI3HDX511E

Ultra-Low Power HDMI1.4b Redriver/DP Level Shifter



Pin Configuration

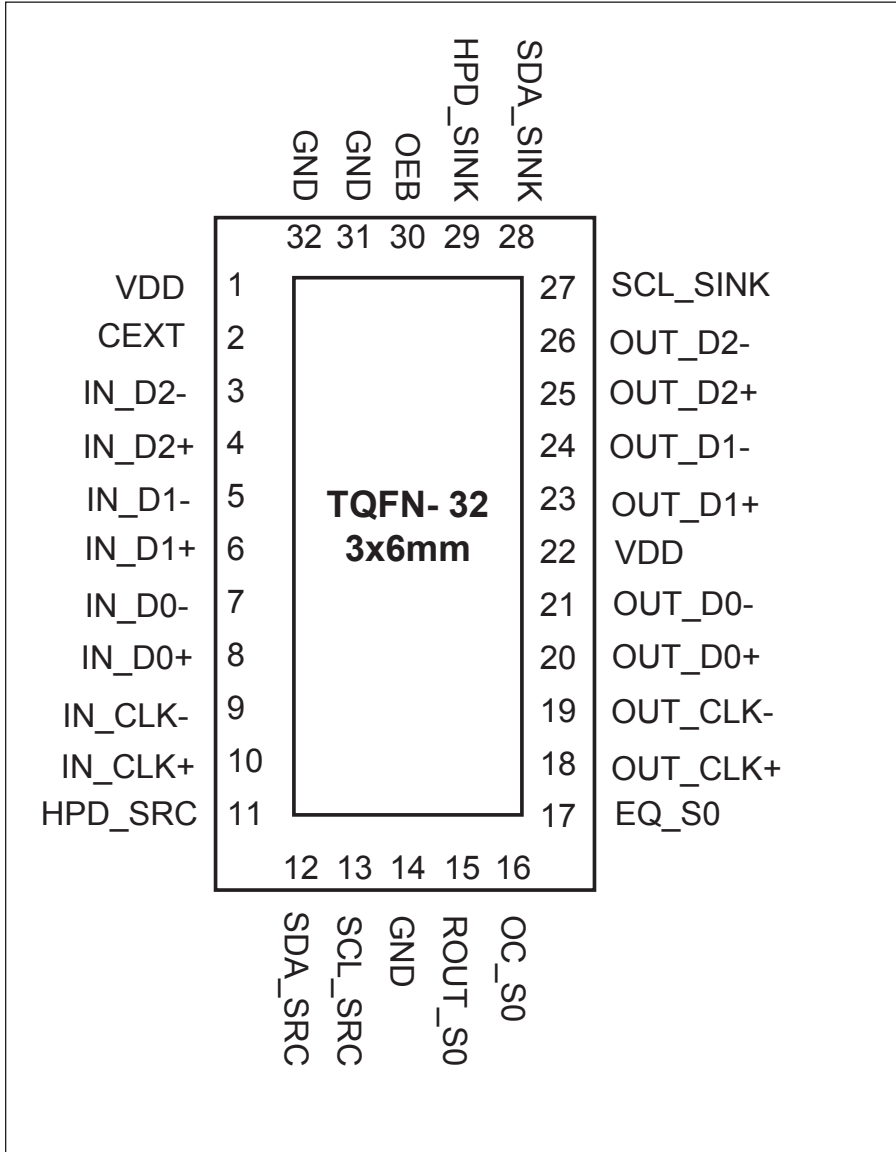



Pin Description

Pin #	Pin Name	Type	Description
1,22	VDD	PWR	3.3V power supply. Add external 0.1uF decoupling capacitor to GND
2	CEXT	PWR	LDO output for internal core supplier. Add external capacitor (2.2uF-4.7uF) to GND
14,31,32	GND	GND	Ground connection
29	HPD_SINK	I	Sink side hot plug detector input; internal pull-down at 120 kohm.
11	HPD_SRC	O	HPD output to source side
3 4 5 6 7 8 9 10	IN_D2- IN_D2+ IN_D1- IN_D1+ IN_D0- IN_D0+ IN_CLK- IN_CLK+	I	TMDS inputs. RT=50ohm; RPD=200kohm.
26 25 24 23 21 20 19 18	OUT_D2- OUT_D2+ OUT_D1- OUT_D1+ OUT_D0- OUT_D0+ OUT_CLK- OUT_CLK+	O	TMDS outputs. ROUT=50ohm is active when ROUT_S0 = "1".
13	SCL_SRC	IO	Source side DDC Clock
12	SDA_SRC	IO	Source side DDC Data
27	SCL_SINK	IO	Sink side DDC Clock for connector
28	SDA_SINK	IO	Sink side DDC Data for connector
16	OC_S0	I	TMDS output three-level pre-emphasis selection. Internal 50% of VDD
17	EQ_S0	I	TMDS input three-level equalization selection. Internal 50% of VDD
30	OEB	I	Output Enable control. Active low. Internal pull-down at 100 kohm.
15	ROUT_S0	I	TMDS output double termination selection. Internally pull-up to VDD.

PI3HDX511E

Ultra-Low Power HDMI1.4b Redriver/DP Level Shifter

**Functional Description****Squelch**

Automatic output squelch function disables TMDS output when no Input signal presents. Output Disable (Squelch) Mode uses TMDS Clock channel signal detection. When low voltage levels on the TMDS input clock signals are detected, Squelch state enables and TMDS output port signals shall disable; when the TMDS clock input signal levels are above a pre-determined threshold voltage, output ports shall return to the normal voltage swing levels.

Hot Plug Detect Sink HPD_SINK Shut Down

When HPD_SINK pin is floating or tie to GND, TMDS outputs shall shut down to sleep mode; HPD_SINK does not control DDC channel.

Pre-emphasis Control OC_S0 Truth Table

Output pre-emphasis setting		Functional Description		Notes
ROUT_S0	OC_S0	Single-end Vswing	Pre-emphasis	
"0"	"0"	500 mV	0 dB	Open drain output
	"NC" or VDD/2	500 mV	1.5 dB	Open drain output, default
	"1"	500 mV	2.5 dB	Open drain output
"1"	"0"	500 mV	0 dB	Double termination
	"NC" or VDD/2	500 mV	1.5 dB	Double termination, default
	"1"	500 mV	2.5 dB	Double termination

Input Equalization EQ_S0 Truth Table

EQ_S0	Functional Description	Note
"0"	2.5 dB	TMDS Clock(CLK) channel EQ is always fixed as 3dB without pre-emphasis.
"NC" or VDD/2	5 dB	
"1"	7.5 dB	

Output Signal Enable OEB Truth Table

OEB	Functional Description
"0"	Normal mode
"1"	Disable output signal for power saving mode

Sink side Hot Plug Detect HPD_SINK Truth Table

HPD_SINK	Functional Description
"1"	Normal mode
"0"	Disable output signal for power saving mode

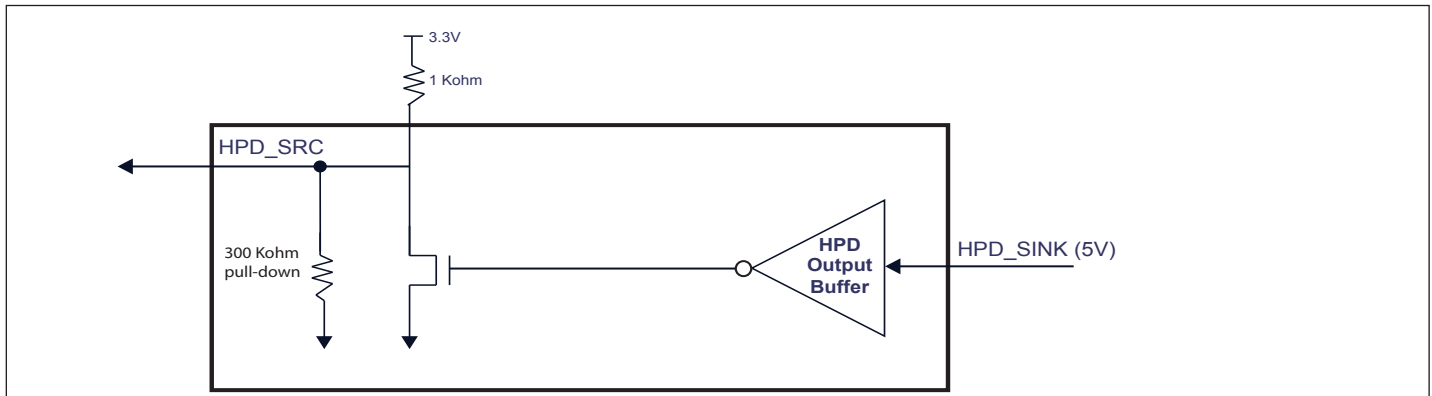
Source side HPD_SRC Output Diagram

Note:

- (1). Open drain buffer is recommended with external pull-up resistor to < 4.5V power supply.

PI3HDX511E

Ultra-Low Power HDMI1.4b Redriver/DP Level Shifter

**Absolute Maximum Ratings**

Item	Absolute Rating ⁽¹⁾
Supply Voltage to Ground Potential	4.5V
All Inputs and Outputs	-0.5V to 4.5V
5V Tolerance I/O (SDA_SINK,SCL_SINK,HPD_SINK)	-0.5V to 5.5V
Storage Temperature	-65 to 150°C
Junction Temperature	125°C
Soldering Temperature	260°C

Note (1) Stress beyond those lists under "Absolute Maximum Ratings" may cause permanent damage to the device

Recommended Operation Conditions

Symbol	Parameter	Min.	Typ.	Max.	Unit
TA	Ambient Operating Temperature	-20		85	°C
VDD	Power Supply Voltage	2.89	3.3	3.6	V

DC Specification (VDD = 3.3V ±10%)

Symbol	Parameter	Conditions	Min.	Typ.	Max.	Unit
VDD	Power Supply Voltage		3.0	3.3	3.6	V
IDD	VDD Supply Current	Open drain 500mV single-end, 0dB pre-emphasis, AC coupled input		80	100	mA
ISTB	Stand-by current	VDD=3.6V, DDC passive switch, HPD_SINK = "0", OEB = "1", ROUT_S0="0"		2	20	uA
ISQLH	Squelch current	VDD=3.6V, DDC passive switch, HPD_SINK=3.6V		2.7	4	mA

HPD_SRC pin

Symbol	Parameter	Conditions	Min.	Typ.	Max.	Unit
VOL	Open Drain Output Low Voltage	IOL = 4 mA	0		0.4	V
IOFF	Off leakage current	VDD=0V, VIN=3.6V			25	μA
IOZ	Open drain Output leakage current	VDD=3.6V, VIN=3.6V			25	

HPD_SINK pin

Symbol	Parameter	Conditions	Min.	Typ.	Max.	Unit
I _{IH}	High level digital input current	V _{IH} = 5.5V	-10		80	μA
I _{IL}	Low level digital input current	V _{IL} = GND	-10		10	μA
V _{IH}	High level digital input voltage	VDD=3.3V	2.0			V
V _{IL}	Low level digital input voltage	VDD=3.3V	0		0.8	V

Control pin (OEB with 100Kohm pull to GND)

Symbol	Parameter	Conditions	Min.	Typ.	Max.	Unit
I _{IH}	High level digital input current	V _{IH} = 3.3V, VDD=3.3V	-10		40	μA
I _{IL}	Low level digital input current	V _{IL} = GND	-10		10	μA
V _{IH}	High level digital input voltage		2.0			V
V _{IL}	Low level digital input voltage		0		0.8	V

Control pin (EQ_S0, OC_S0 with 100Kohm pull up and 100Kohm pull down when TMDS active)

Symbol	Parameter	Conditions	Min.	Typ.	Max.	Unit
I _{IH}	High level digital input current	V _{IH} = 3.3V	-10		40	μA
I _{IL}	Low level digital input current	V _{IL} = GND, VDD=3.3V	-40		10	μA

Control pin (ROUT_S0)

Symbol	Parameter	Conditions	Min.	Typ.	Max.	Unit
I _{IH}	High level digital input current	V _{IH} = VDD	-10		10	μA
I _{IL}	Low level digital input current	V _{IL} = GND	-20		10	μA
V _{IH}	High level digital input voltage		2.0			V
V _{IL}	Low level digital input voltage		0		0.8	V

DDC channel switch

Symbol	Parameter	Conditions	Min.	Typ.	Max.	Unit
I _{LK}	Input leakage current	DDC switch is OFF, V _{in} =5.5V	-10		30	μA
C _{IO}	Input/Output capacitance when passive switch on	V _{Ipp} (peak-peak) = 1V, 100KHz		10		pF
R _{ON}	Passive Switch resistance	I _O = 3mA, V _O = 0.4V		30	50	Ω
V _{PASS}	Switch Output voltage	V _I =3.3V, I _I =100uA VDD=3.3V	1.5	2.0	2.5	V

PI3HDX511E

Ultra-Low Power HDMI1.4b Redriver/DP Level Shifter



TMDS differential pins						
Symbol	Parameter	Conditions	Min.	Typ.	Max.	Unit
VOH	Single-ended high level output voltage	VDD = 3.3V ROUT=50Ω	VDD-10		VDD+10	mV
VOL	Single-ended low level output voltage		VDD-600		VDD-400	mV
VSWING	Single-ended output swing voltage		400		600	mV
VOD(O) ^{*1}	Overshoot of output differential voltage				180 ⁽¹⁾	mV
VOD(U) ^{*2}	Undershoot of output differential voltage				200 ⁽²⁾	mV
VOC(SS)	Change in steady-state common-mode output voltage between logic states				5	mV
IOS	Short Circuit output current at open drain mode	Short to VDD	-12		12	mA
	Short Circuit output current at double termination mode	Short to VDD	-24		24	mA
VI(open)	Single-ended input voltage under high impedance input or open input	II = 10uA	VDD-10		VDD+10	mV
RT	Input termination resistance	VIN = 2.9V	45	50	55	Ω
IOZ	Leakage current with Hi-Z I/O	VDD = 3.6V, /OEB=High			30	μA

Note:

(1) Overshoot of output differential voltage $VOD(O) = (VSWING(MAX) * 2) * 15\%$ (2) Undershoot of output differential voltage $VOD(O) = (VSWING(MIN) * 2) * 25\%$

AC Characteristics (Over recommended operating conditions unless otherwise noted)

Symbol	Parameter	Test Condition	Min.	Typ.	Max.	Units
TMDS differential pins						
tPD	Propagation delay	VDD = 3.3V ROUT = 50Ω			2000	ps
tR/tF	Differential output signal rise/fall time(20% - 80%), open drain, 0dB pre-emphasis			120		
	Differential output signal rise/fall time (20% - 80%), open drain, 2.5dB pre-emphasis			100		
tSK(P)	Pulse skew			10	50	
tSK(D)	Intra-pair differential skew			23	50	
tSK(O)	Inter-pair differential skew				100	
tJIT(PP)	Peak-to-peak output Clock residual jitter	Data Input = 3.4 Gbps		30	60	
tJIT(PP)	Peak-to-peak output DATA Residual Jitter	HDMI data patterns		40	70	
tEN	Enable time				50	μs
tDIS	Disable time				0.01	
DDC I/O pins (passive switch)						
tPD(DDC)	Propagation delay : SCL_SINK/SDA_SINK to SCL/SDA or SCL/ SDA to SCL_SINK/SDA_SINK in passive SW	CL = 10pF			5	ns
Control and Status Pins (HPD_SINK, HPD)						
tPD(HPD)	Propagation delay : From HPD_SINK to the active port of HPD, high to low	CL = 10pF, Pull high resistor=1kΩ Open drain		10		ns

PI3HDX511E

Ultra-Low Power HDMI1.4b Redriver/DP Level Shifter



TMDS Input Measurement Test Setup

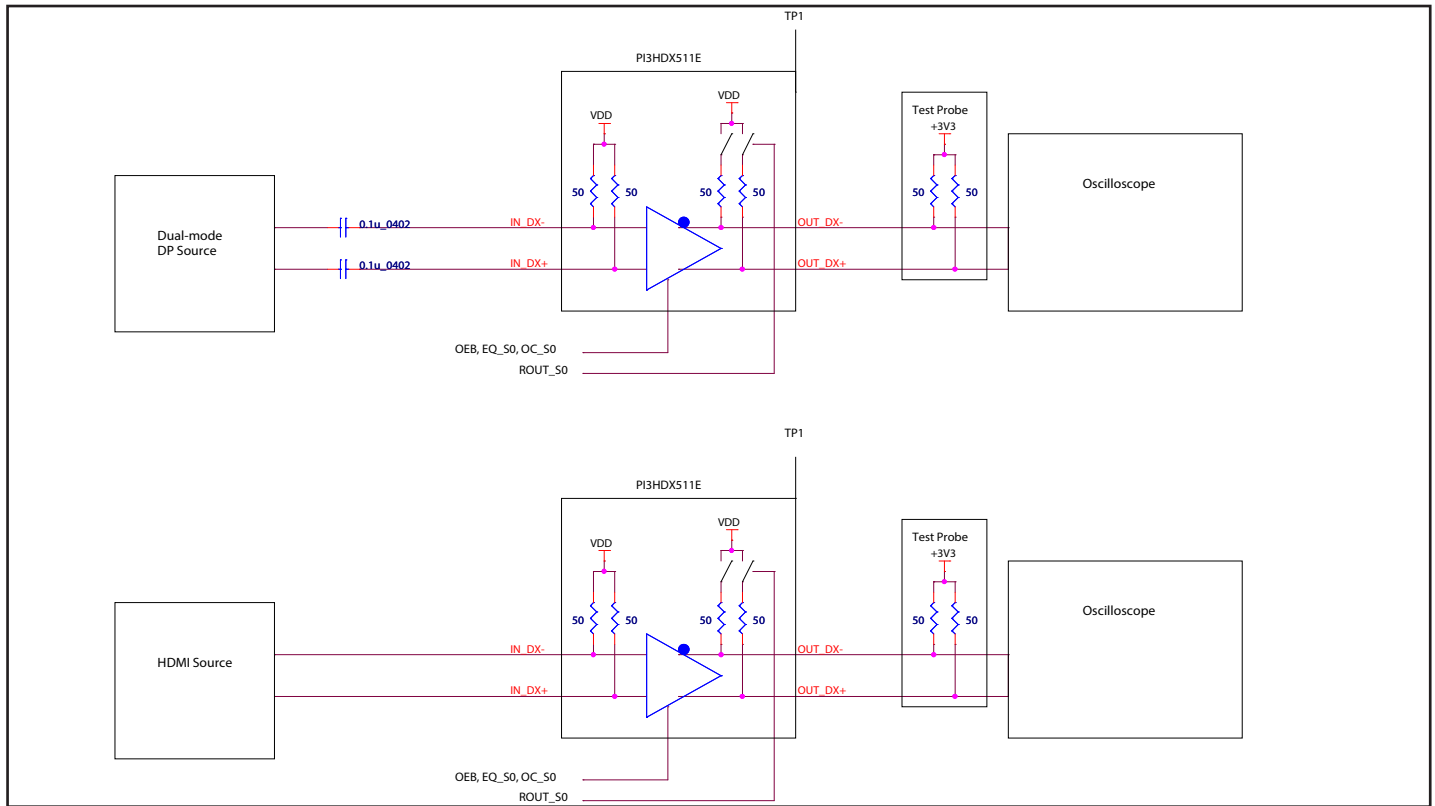

Rise/Fall Time and Single-ended Swing Voltage

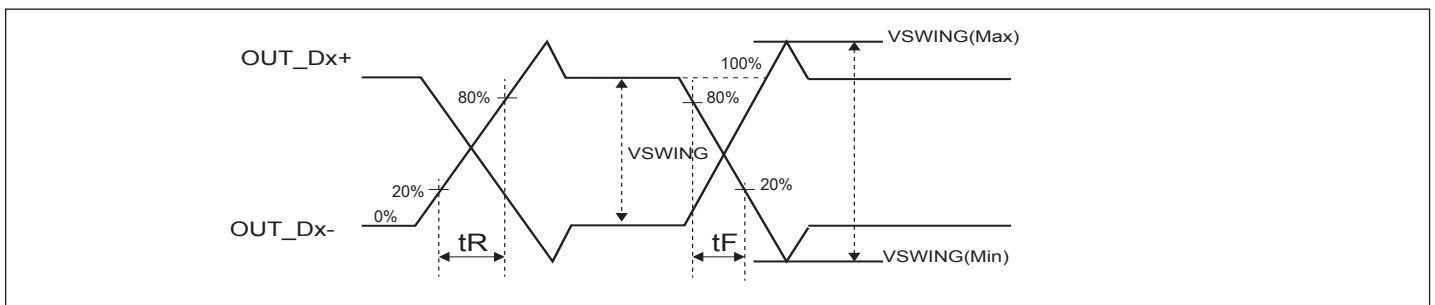

Intra-pair Skew Definition

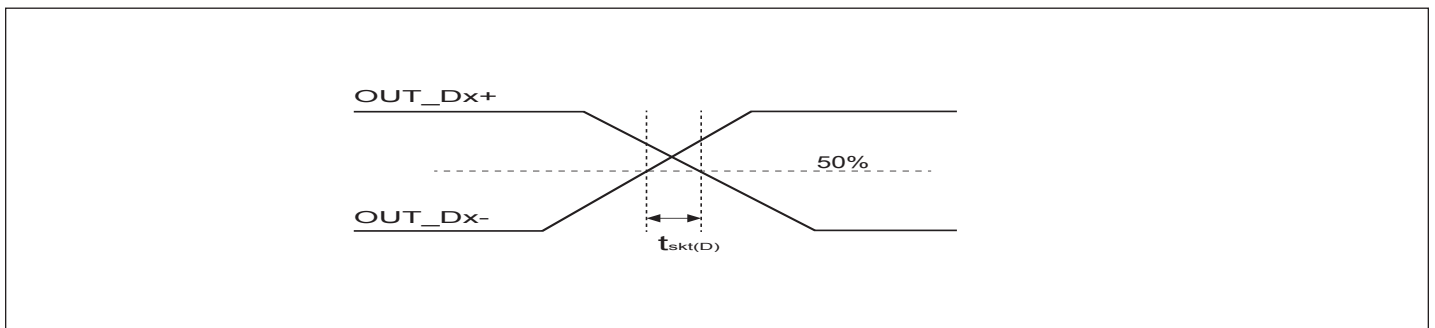

Decoupling Capacitors near VDD Pins

Each VDD pins requires to add 0.1 μF and 10 μF decoupling capacitors with optional Ferrite bead in order to isolate the power supply from the other circuitry. The capacitor material do not have special requirements. Ceramic capacitors are generally recommended with X5R or X7R materials.

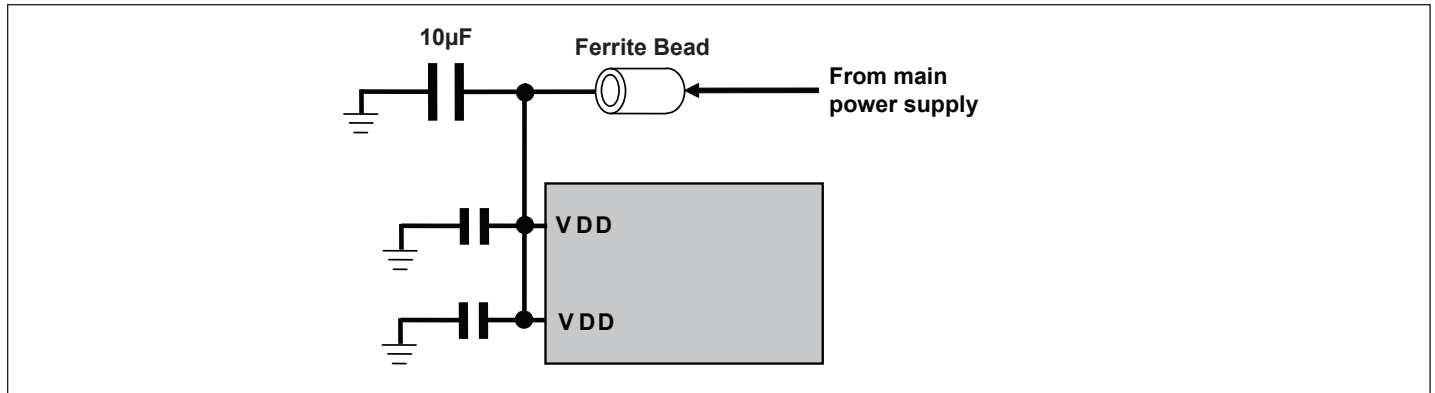

Decoupling Capacitors and Ferrite Bead near VDD Pins

Decoupling Capacitors in PCB Layout

- Each 0.1 μF decoupling capacitor should be placed as close as possible to each VDD pin.
- VDD and GND planes should be used to provide a low impedance path for power and ground.
- Via holes should be placed to connect to VDD and GND planes directly.
- Trace should be as wide and short as possible.
- The placement of decoupling capacitor and the way of routing trace should consider the power flowing criteria.
- 10 μF Capacitor should also be placed closed to our part and should be placed in the middle location of 0.1 μF capacitors.
- Avoid the large current circuit placed close to our part; especially when it is shared the same VDD and GND planes. Since large current flowing on our VDD or GND planes will generate a potential variation on the VDD or GND of our part.

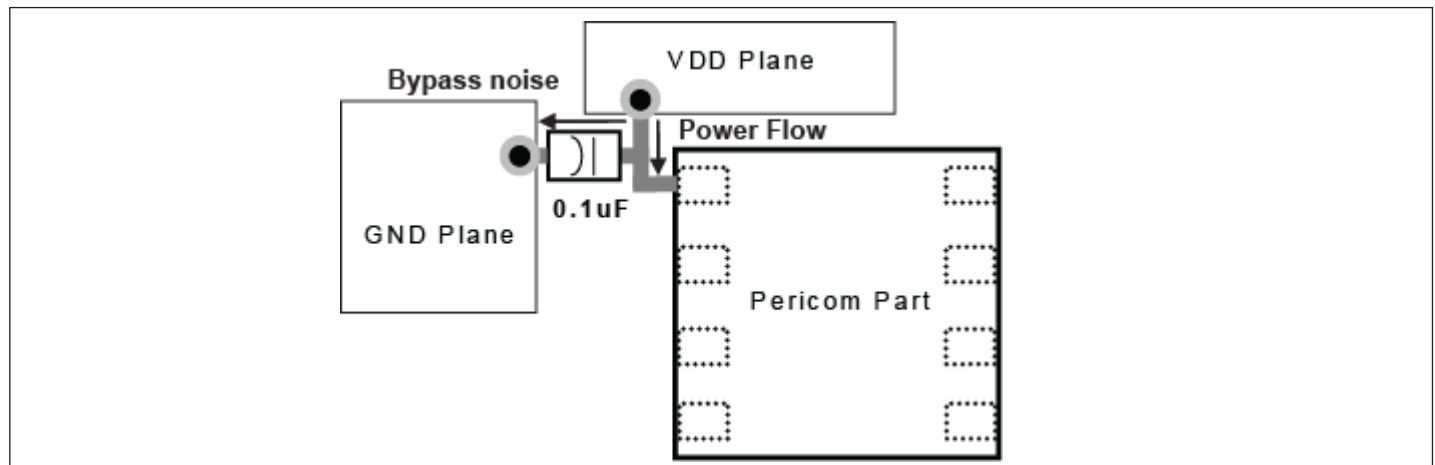

Decoupling Capacitor location in PCB design

PI3HDX511E

Ultra-Low Power HDMI1.4b Redriver/DP Level Shifter



Packaging Mechanical: 32-Contact TQFN (ZLS)

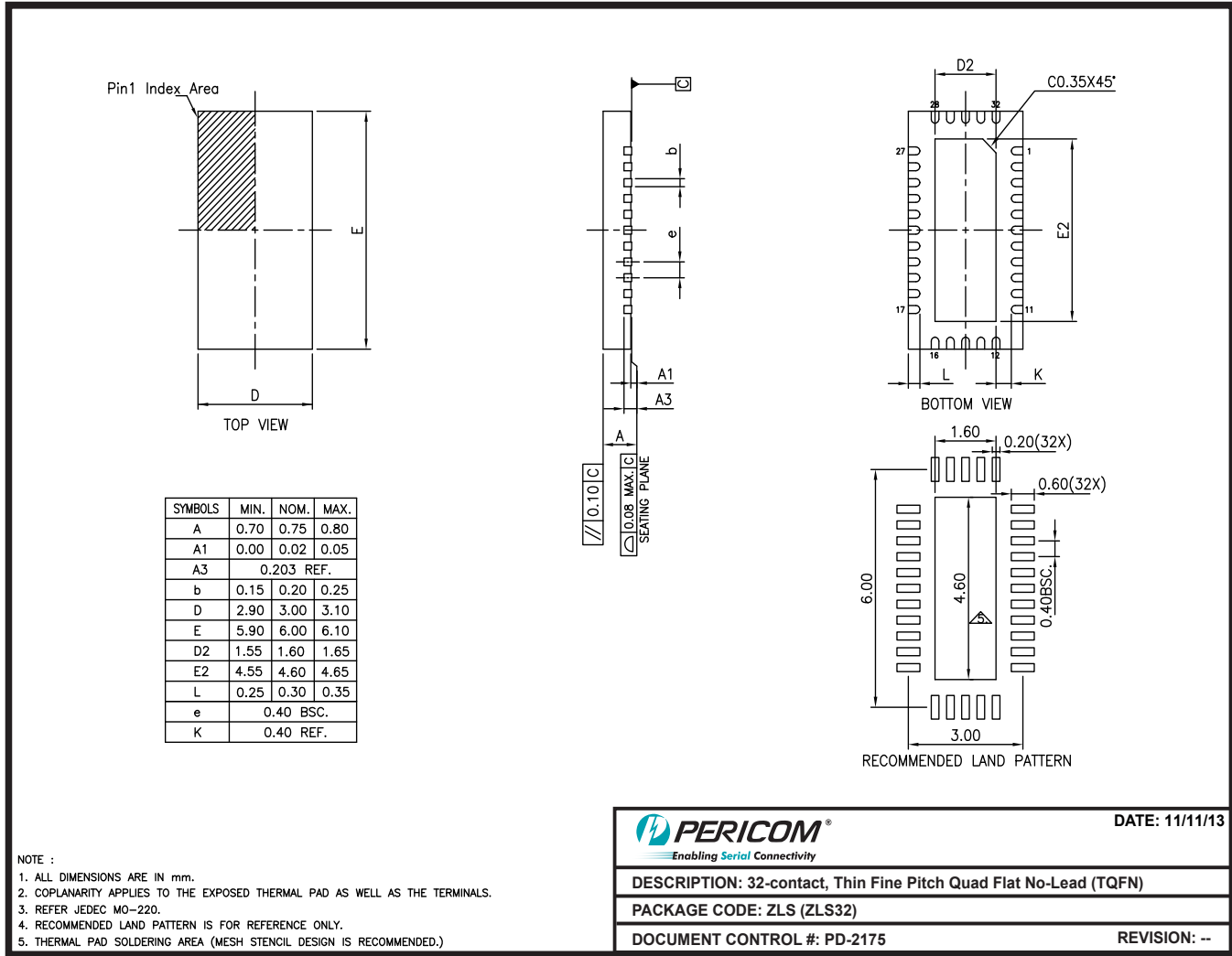

Please check for the latest package information on the Pericom web site at www.pericom.com/support/packaging.

Ordering Information

Ordering Number	Package Code	Package Description
PI3HDX511EZLSE	ZLS	32-Contact, Thin Fine Pitch Quad Flat No Lead Package (TQFN)

- Thermal characteristics can be found on the company web site at www.pericom.com/packaging/
- E = Pb-free and Green
- X suffix = Tape/Reel



Related Products

Part Number	Product Description
PI3WVR12612	Wide Voltage Range DisplayPort™ & HDMI Video Switch
PI3HDX1204-B	HDMI2.0 Redriver and Displayport Level Shifter for 6Gbps Application
PI3EQXDP1201	Displayport 1.2 redriver with built-in auto test mode
PI3HDX414	1:4 Active 3.4Gbps HDMI1.4b Splitter/DeMux with Signal Conditioning
PI3HDX412BD	1:2 Active 3.4Gbps HDMI1.4b Splitter/DeMux with Signal Conditioning
PI3HDX621	2:1 Active 3.4Gbps HDMI 1.4b Switch
PI3HDMI336	3:1 Active 2.5Gbps HDMI Switch with I2C control and ARC Transmitter

Reference Information

Document	Description
HDMI1.4b	High-Definition Multimedia Interface Specification Version 1.4, HDMI Licensing, LLC

INFORMATION IN THIS DOCUMENT IS PROVIDED IN CONNECTION WITH PERICOM PRODUCT. NO LICENSE, EXPRESS OR IMPLIED, BY ESTOPPEL OR OTHERWISE, TO ANY INTELLECTUAL PROPERTY RIGHTS IS GRANTED BY THIS DOCUMENT. EXCEPT AS PROVIDED IN PERICOM'S TERMS AND CONDITIONS OF SALE FOR SUCH PRODUCTS INCLUDING LIABILITY OR WARRANTIES RELATING TO FITNESS FOR A PARTICULAR PURPOSE, MERCHANTABILITY, OR INFRINGEMENT OF ANY PATENT, COPYRIGHT OR OTHER INTELLECTUAL PROPERTY RIGHT.

Pericom may make changes to specifications and product descriptions at any time, without notice. Designers must not rely on the absence or characteristics of any features or instructions marked "reserved" or "undefined". Pericom reserves these for future definition and shall have no responsibility whatsoever for conflicts or incompatibilities arising from future changes to them. The products described in this document may contain design defects or errors known as errata which may cause the product to deviate from published specification. Current characterized errata are available on request.

Contact your local Pericom Sales office or your distributor to obtain the latest specifications and before placing your product order.

Copyright 2014 Pericom Corporation. All rights reserved. Pericom and the Pericom logo are trademarks of Pericom Corporation in the U.S. and other countries.