

INSULATED GATE BIPOLAR TRANSISTOR WITH ULTRAFAST SOFT RECOVERY DIODE

Features

- Low $V_{CE(on)}$
- Zero $V_{CE(on)}$ temperature coefficient
- $3\mu s$ Short Circuit Capability
- Square RBSOA

Benefits

- Benchmark Efficiency for Motor Control Applications
- Rugged Transient Performance
- Low EMI

Applications

- Air Conditioner Compressor
- Refrigerator
- Vacuum Cleaner
- Low Frequency Inverter

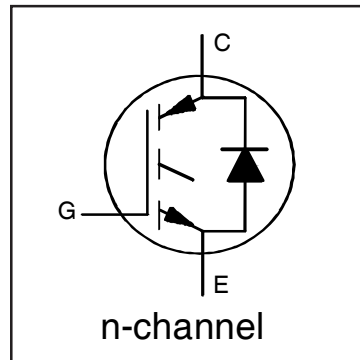

$V_{CES} = 600V$
$I_{NOM} = 24A$
$V_{CE(on)} \text{ typ.} = 1.60V$
$t_{SC} \geq 3\mu s, T_{J(max)} = 150^\circ C$

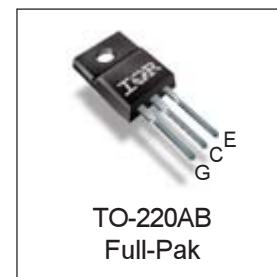

G	C	E
Gate	Collector	Emitter

Absolute Maximum Ratings

	Parameter	Max.	Units
V_{CES}	Collector-to-Emitter Voltage	600	V
$I_C @ T_C = 25^\circ C$	Continuous Collector Current	24	A
$I_C @ T_C = 100^\circ C$	Continuous Collector Current	12	
I_{CM}	Pulse Collector Current, $V_{GE} = 15V$	72	
I_{LM}	Clamped Inductive Load Current, $V_{GE} = 20V$ ①	96	
$I_F @ T_C = 25^\circ C$	Diode Continuous Forward Current	24	
$I_F @ T_C = 100^\circ C$	Diode Continuous Forward Current	12	
I_{FM}	Diode Maximum Forward Current ②	96	
V_{GE}	Gate-to-Emitter Voltage	± 30	
$P_D @ T_C = 25^\circ C$	Maximum Power Dissipation	42	W
$P_D @ T_C = 100^\circ C$	Maximum Power Dissipation	17	
T_J T_{STG}	Operating Junction and Storage Temperature Range	-55 to +150	$^\circ C$
	Soldering Temperature, for 10 sec.	300 (0.063 in. (1.6mm) from case)	
	Mounting Torque, 6-32 or M3 Screw	10 lbf-in (1.1 N-m)	

Thermal Resistance

	Parameter	Min.	Typ.	Max.	Units
$R_{\theta JC}$ (IGBT)	Thermal Resistance Junction-to-Case-(each IGBT) ③	—	—	3.0	$^\circ C/W$
$R_{\theta JC}$ (Diode)	Thermal Resistance Junction-to-Case-(each Diode) ③	—	—	3.7	
$R_{\theta JA}$	Thermal Resistance, Junction-to-Ambient (typical socket mount)	—	65	—	

Electrical Characteristics @ T_J = 25°C (unless otherwise specified)

	Parameter	Min.	Typ.	Max.	Units	Conditions
V _{(BR)CES}	Collector-to-Emitter Breakdown Voltage	600	—	—	V	V _{GE} = 0V, I _C = 1.0mA
ΔV _{(BR)CES/ΔT_J}	Temperature Coeff. of Breakdown Voltage	—	0.51	—	V/°C	V _{GE} = 0V, I _C = 2.0mA (25°C-150°C)
V _{CE(on)}	Collector-to-Emitter Saturation Voltage	—	1.60	1.85	V	I _C = 24A, V _{GE} = 15V, T _J = 25°C ②
		—	1.60	—		I _C = 24A, V _{GE} = 15V, T _J = 150°C ②
V _{GE(th)}	Gate Threshold Voltage	4.5	—	7.0	V	V _{CE} = V _{GE} , I _C = 1.0mA
ΔV _{GE(th)/ΔT_J}	Threshold Voltage temp. coefficient	—	-14	—	mV/°C	V _{CE} = V _{GE} , I _C = 1.0mA (25°C - 150°C)
g _{fe}	Forward Transconductance	—	26	—	S	V _{CE} = 50V, I _C = 24A, PW = 30μs
I _{CES}	Collector-to-Emitter Leakage Current	—	1.0	30	μA	V _{GE} = 0V, V _{CE} = 600V
		—	1.3	—	mA	V _{GE} = 0V, V _{CE} = 600V, T _J = 150°C
V _{FM}	Diode Forward Voltage Drop	—	1.50	1.80	V	I _F = 24A
		—	1.40	—		I _F = 24A, T _J = 150°C
I _{GES}	Gate-to-Emitter Leakage Current	—	—	±100	nA	V _{GE} = ±30V

Switching Characteristics @ T_J = 25°C (unless otherwise specified)

	Parameter	Min.	Typ.	Max. ④	Units	Conditions
Q _g	Total Gate Charge (turn-on)	—	88	130	nC	I _C = 24A
Q _{ge}	Gate-to-Emitter Charge (turn-on)	—	17	26		V _{GE} = 15V
Q _{gc}	Gate-to-Collector Charge (turn-on)	—	43	65		V _{CC} = 400V
E _{on}	Turn-On Switching Loss	—	785	1015	μJ	I _C = 24A, V _{CC} = 400V, V _{GE} = 15V
E _{off}	Turn-Off Switching Loss	—	780	1010		R _G = 22Ω, L = 400μH, T _J = 25°C
E _{total}	Total Switching Loss	—	1570	2020		Energy losses include tail & diode reverse recovery
t _{d(on)}	Turn-On delay time	—	58	76	ns	I _C = 24A, V _{CC} = 400V, V _{GE} = 15V
t _r	Rise time	—	36	54		R _G = 22Ω, L = 400μH, T _J = 25°C
t _{d(off)}	Turn-Off delay time	—	249	283		
t _f	Fall time	—	114	133		
E _{on}	Turn-On Switching Loss	—	1090	—		μJ
E _{off}	Turn-Off Switching Loss	—	1530	—	R _G = 22Ω, L = 400μH, T _J = 150°C	
E _{total}	Total Switching Loss	—	2620	—	Energy losses include tail & diode reverse recovery	
t _{d(on)}	Turn-On delay time	—	54	—	ns	I _C = 24A, V _{CC} = 400V, V _{GE} = 15V
t _r	Rise time	—	35	—		R _G = 22Ω, L = 400μH
t _{d(off)}	Turn-Off delay time	—	295	—		T _J = 150°C
t _f	Fall time	—	277	—		
C _{ies}	Input Capacitance	—	2400	—		pF
C _{oes}	Output Capacitance	—	130	—	V _{CC} = 30V	
C _{res}	Reverse Transfer Capacitance	—	57	—	f = 1.0MHz	
RBSOA	Reverse Bias Safe Operating Area	FULL SQUARE				T _J = 150°C, I _C = 96A V _{CC} = 480V, V _p ≤ 600V R _G = 22Ω, V _{GE} = +20V to 0V
SCSOA	Short Circuit Safe Operating Area	3	—	—	μs	V _{GE} = 15V, V _{CC} = 400V, V _p ≤ 600V R _G = 22Ω, R _{shunt} = 11mΩ, T _C = 100°C
E _{rec}	Reverse Recovery Energy of the Diode	—	147	—	μJ	T _J = 150°C
t _{rr}	Diode Reverse Recovery Time	—	105	—	ns	V _{CC} = 400V, I _F = 24A
I _{rr}	Peak Reverse Recovery Current	—	22	—	A	V _{GE} = 15V, R _G = 22Ω, L = 400μH

Notes:

- ① V_{CC} = 80% (V_{CES}), V_{GE} = 20V, L = 400μH, R_G = 22Ω.
- ② Pulse width limited by max. junction temperature.
- ③ R_θ is measured at T_J of approximately 90°C.
- ④ Maximum limits are based on statistical sample size characterization.

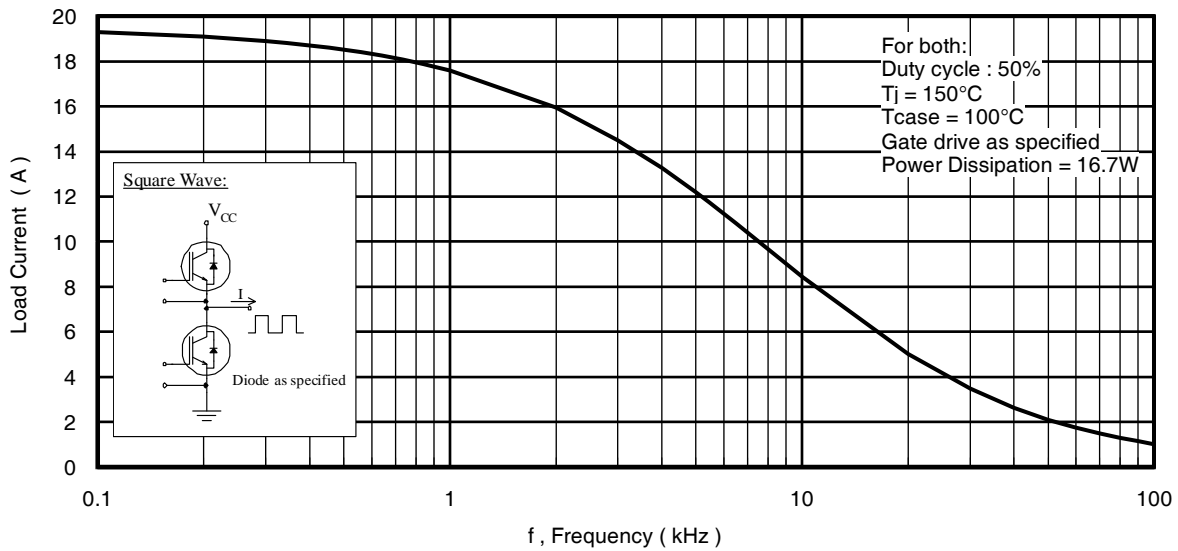

Fig. 1 - Typical Load Current vs. Frequency
(Load Current = I_{RMS} of fundamental)

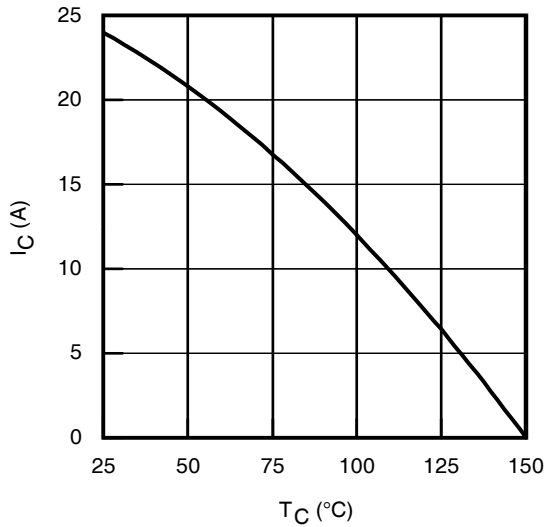

Fig. 2 - Maximum DC Collector Current vs. Case Temperature

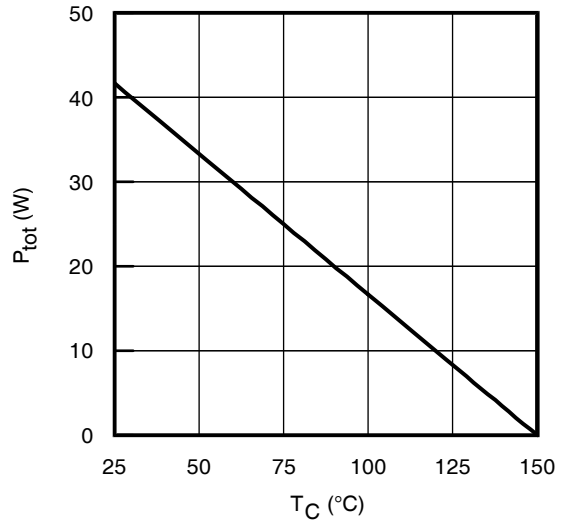

Fig. 3 - Power Dissipation vs. Case Temperature

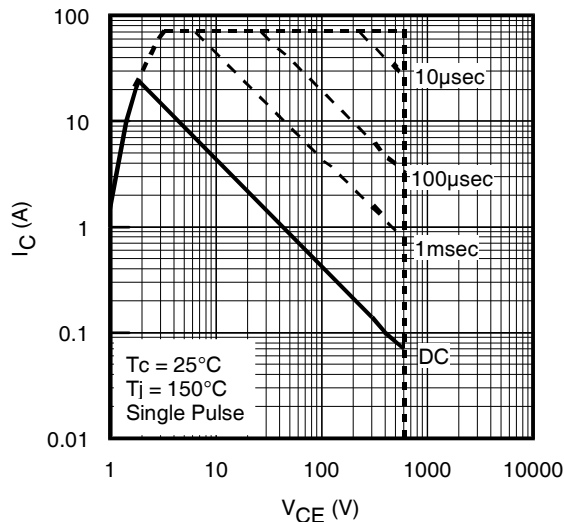

Fig. 4 - Forward SOA
 $T_C = 25^\circ\text{C}$, $T_J \leq 150^\circ\text{C}$, $V_{GE} = 15\text{V}$

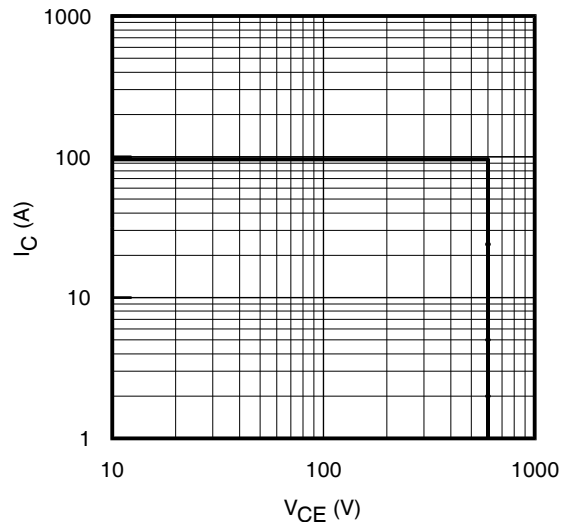

Fig. 5 - Reverse Bias SOA
 $T_J = 150^\circ\text{C}$, $V_{GE} = 20\text{V}$

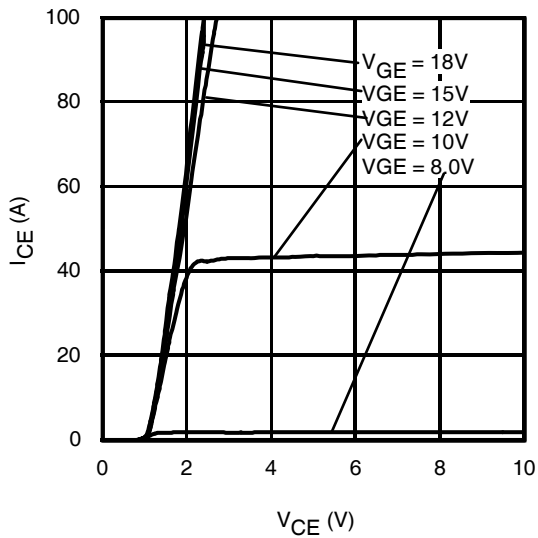

Fig. 6 - Typ. IGBT Output Characteristics
 $T_J = -40^\circ\text{C}$; $t_p = 30\mu\text{s}$

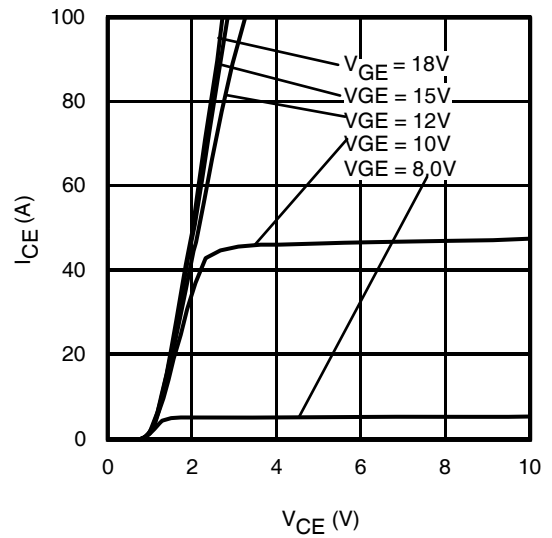

Fig. 7 - Typ. IGBT Output Characteristics
 $T_J = 25^\circ\text{C}$; $t_p = 30\mu\text{s}$

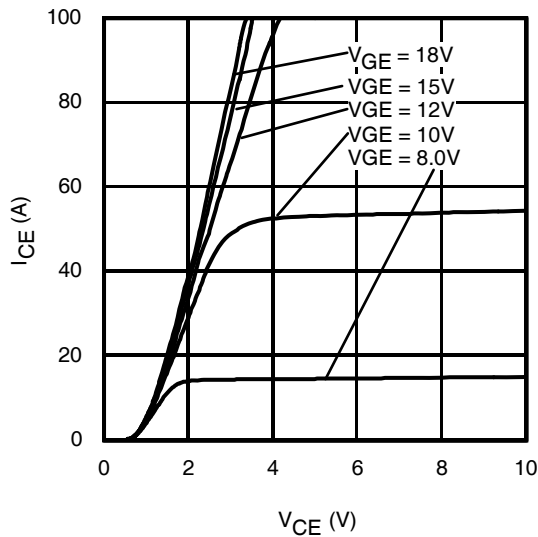

Fig. 8 - Typ. IGBT Output Characteristics
 $T_J = 150^\circ\text{C}$; $t_p = 30\mu\text{s}$

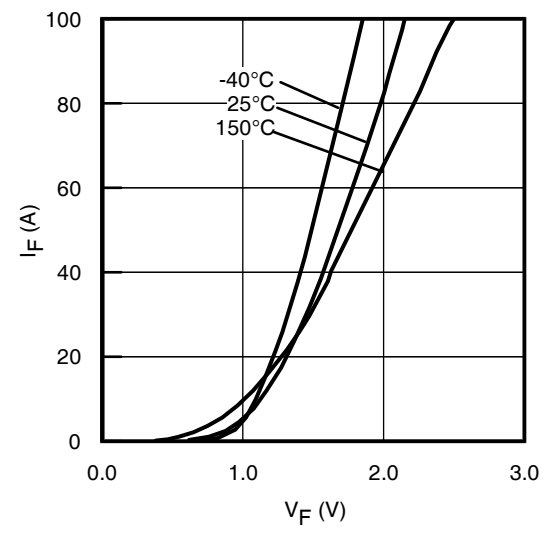

Fig. 9 - Typ. Diode Forward Characteristics
 $t_p = 30\mu\text{s}$

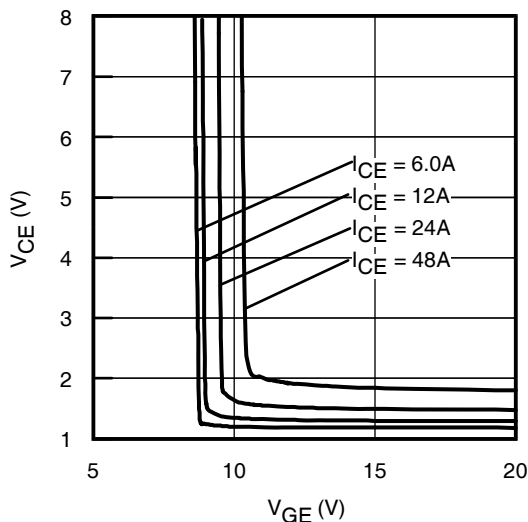

Fig. 10 - Typical V_{CE} vs. V_{GE}
 $T_J = -40^\circ\text{C}$

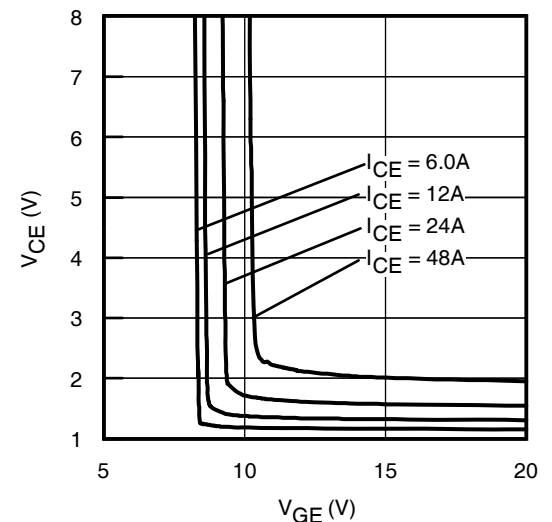

Fig. 11 - Typical V_{CE} vs. V_{GE}
 $T_J = 25^\circ\text{C}$

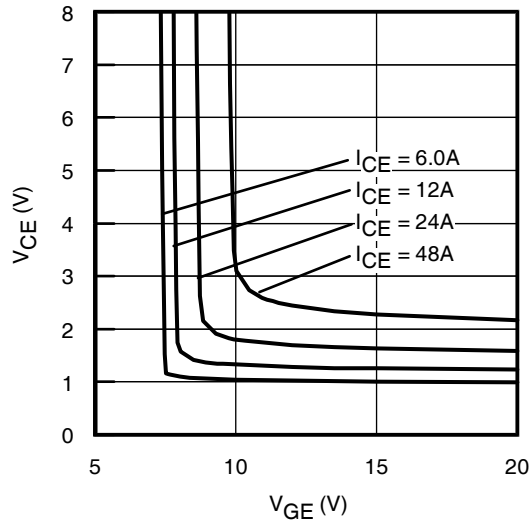

Fig. 12 - Typical V_{CE} vs. V_{GE}
 $T_J = 150^\circ\text{C}$

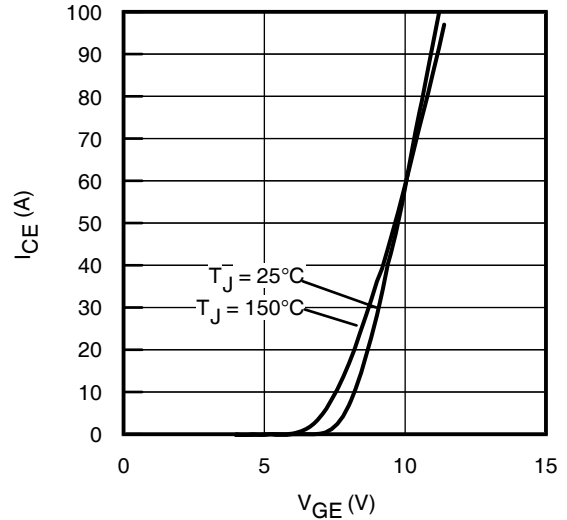

Fig. 13 - Typ. Transfer Characteristics
 $V_{CE} = 25\text{V}$; $t_p = 30\mu\text{s}$

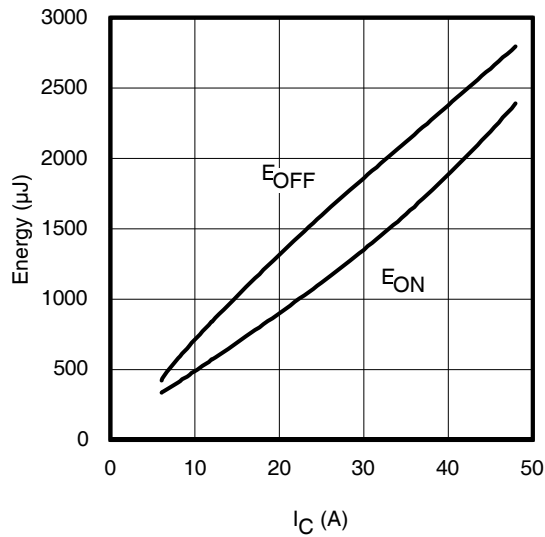

Fig. 14 - Typ. Energy Loss vs. I_C
 $T_J = 150^\circ\text{C}$; $L = 400\mu\text{H}$; $V_{CE} = 400\text{V}$; $R_G = 22\Omega$; $V_{GE} = 15\text{V}$

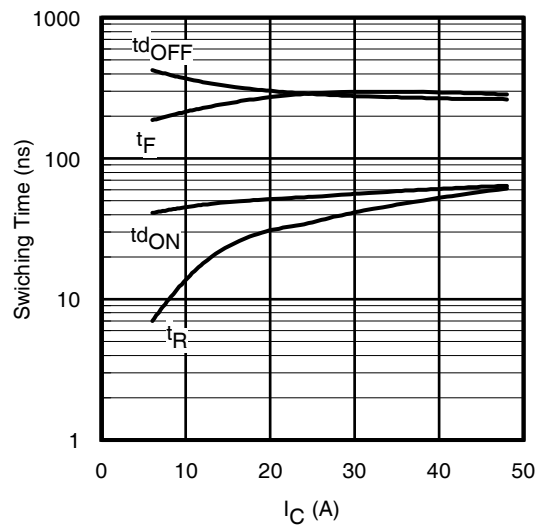

Fig. 15 - Typ. Switching Time vs. I_C
 $T_J = 150^\circ\text{C}$; $L = 400\mu\text{H}$; $V_{CE} = 400\text{V}$; $R_G = 22\Omega$; $V_{GE} = 15\text{V}$

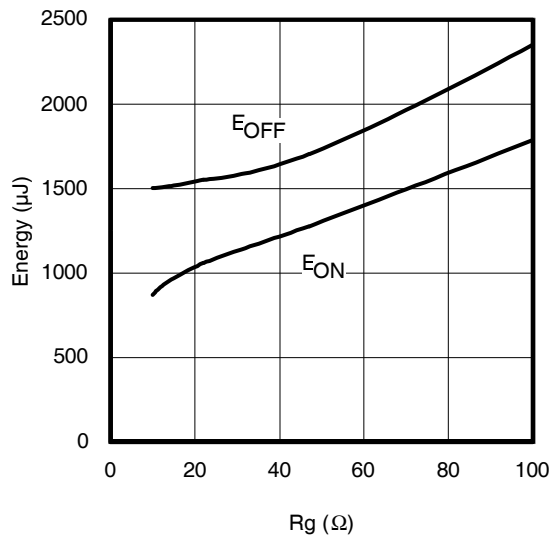

Fig. 16 - Typ. Energy Loss vs. R_G
 $T_J = 150^\circ\text{C}$; $L = 400\mu\text{H}$; $V_{CE} = 400\text{V}$; $I_{CE} = 24\text{A}$; $V_{GE} = 15\text{V}$

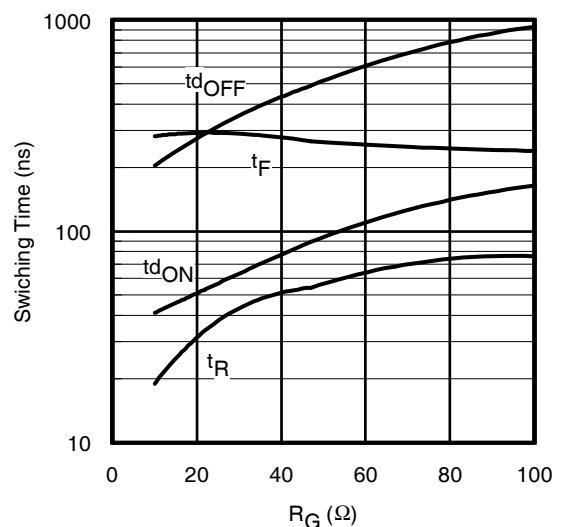

Fig. 17 - Typ. Switching Time vs. R_G
 $T_J = 150^\circ\text{C}$; $L = 400\mu\text{H}$; $V_{CE} = 400\text{V}$; $I_{CE} = 24\text{A}$; $V_{GE} = 15\text{V}$

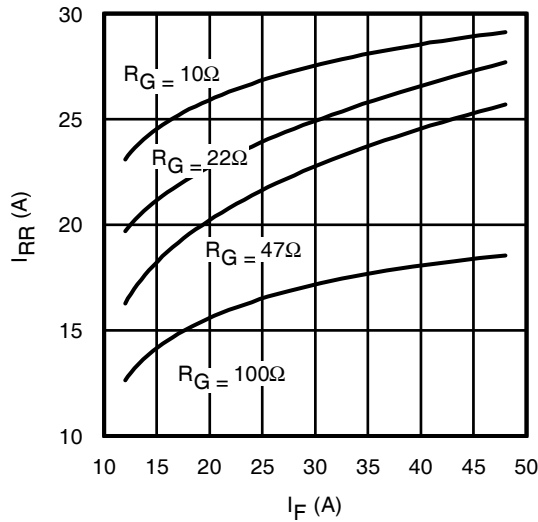

Fig. 18 - Typ. Diode I_{RR} vs. I_F
 $T_J = 150^\circ\text{C}$

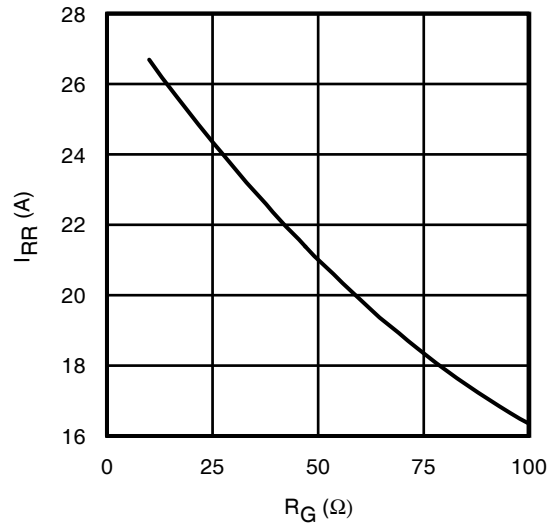

Fig. 19 - Typ. Diode I_{RR} vs. R_G
 $T_J = 150^\circ\text{C}$

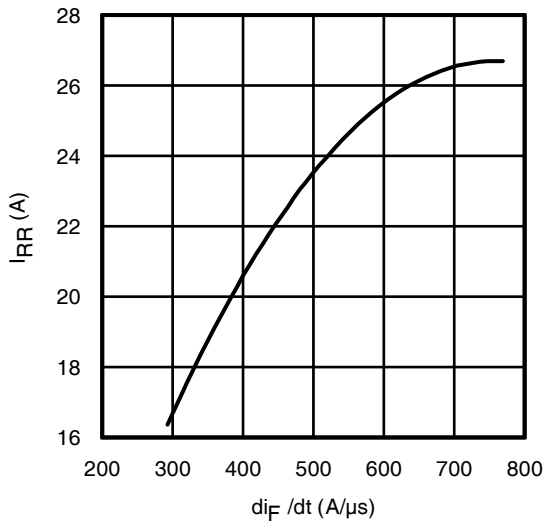

Fig. 20 - Typ. Diode I_{RR} vs. di_F/dt
 $V_{CC} = 400\text{V}$; $V_{GE} = 15\text{V}$; $I_F = 24\text{A}$; $T_J = 150^\circ\text{C}$

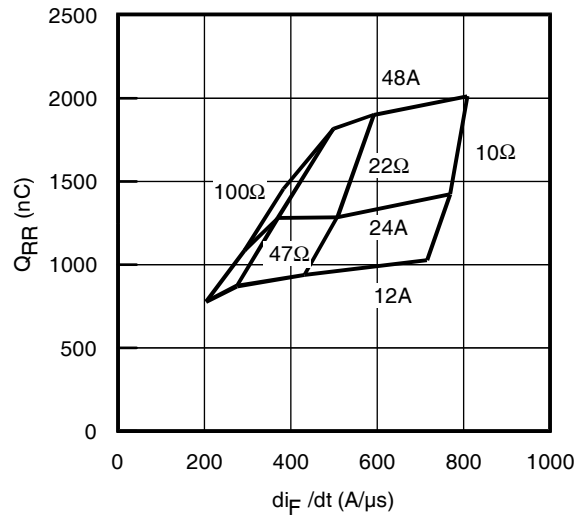

Fig. 21 - Typ. Diode Q_{RR} vs. di_F/dt
 $V_{CC} = 400\text{V}$; $V_{GE} = 15\text{V}$; $T_J = 150^\circ\text{C}$

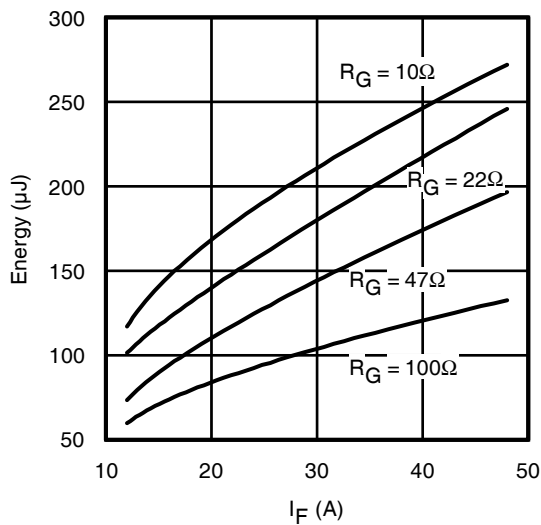

Fig. 22 - Typ. Diode E_{RR} vs. I_F
 $T_J = 150^\circ\text{C}$

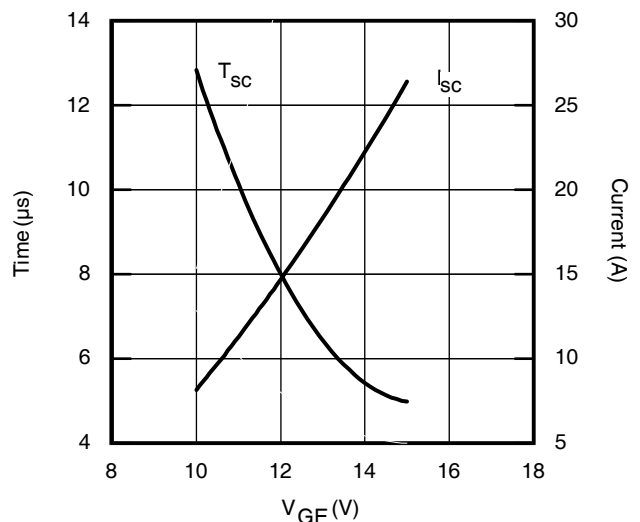

Fig. 23 - V_{GE} vs. Short Circuit Time
 $V_{CC} = 400\text{V}$; $T_C = 25^\circ\text{C}$

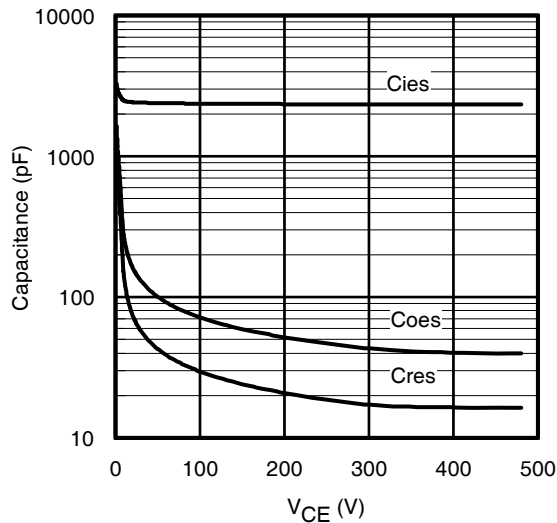

Fig. 24 - Typ. Capacitance vs. V_{CE}
 $V_{GE} = 0V$; $f = 1MHz$

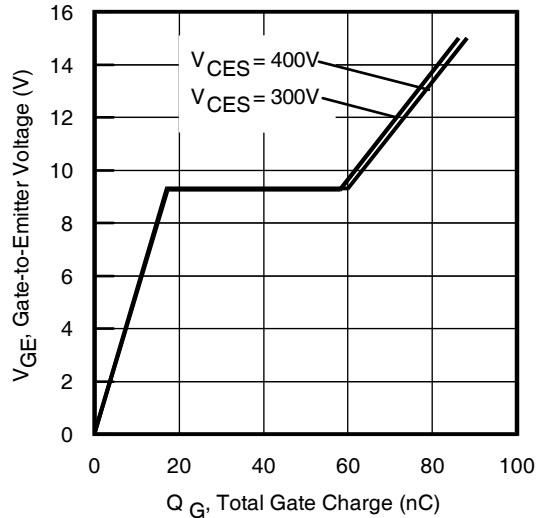

Fig. 25 - Typical Gate Charge vs. V_{GE}
 $I_{CE} = 24A$; $L = 600\mu H$

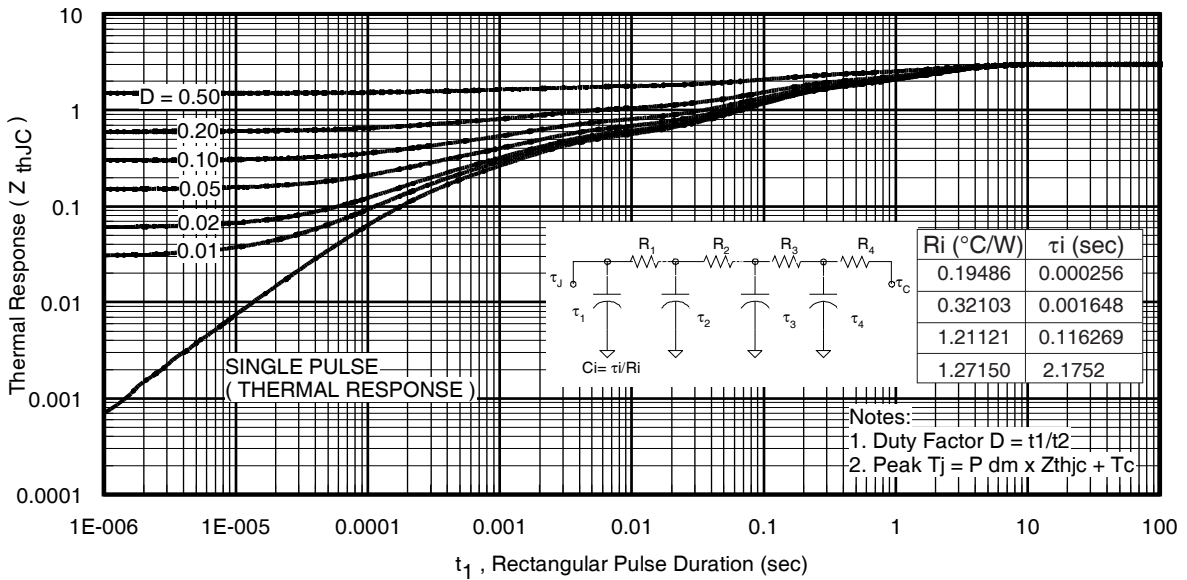

Fig. 26. Maximum Transient Thermal Impedance, Junction-to-Case (IGBT)

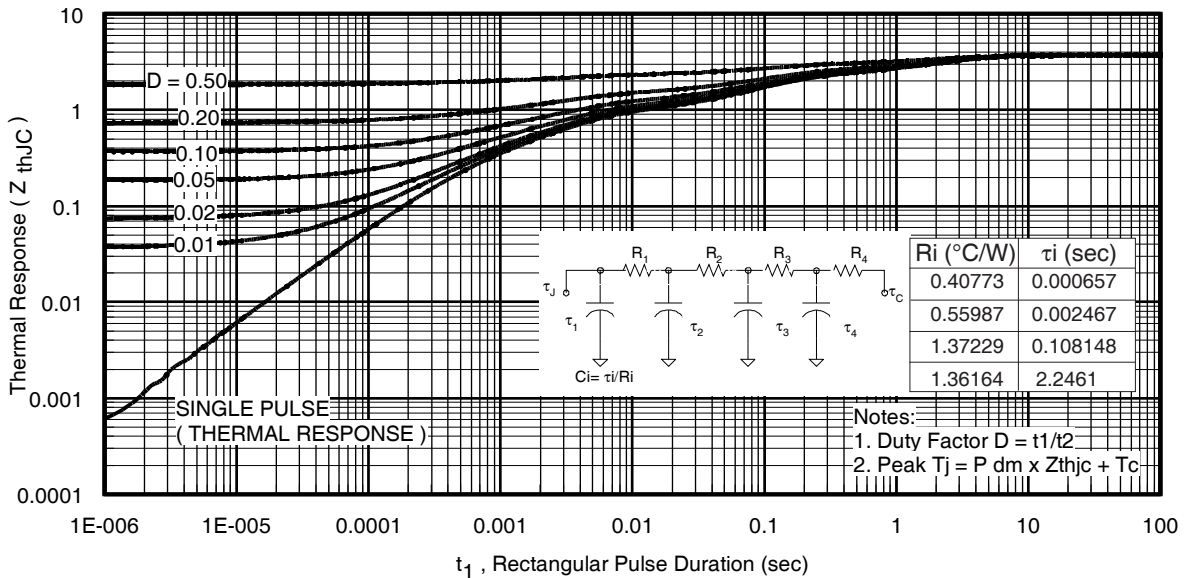
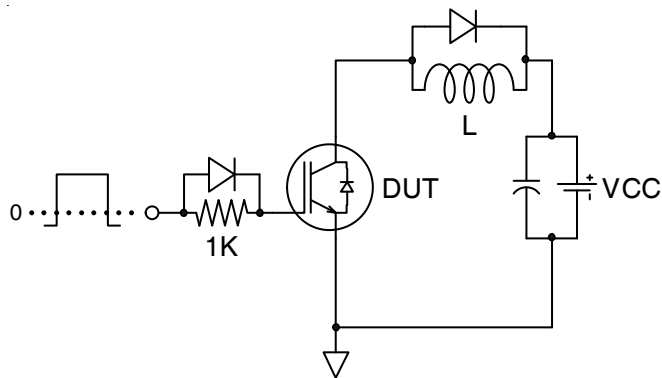
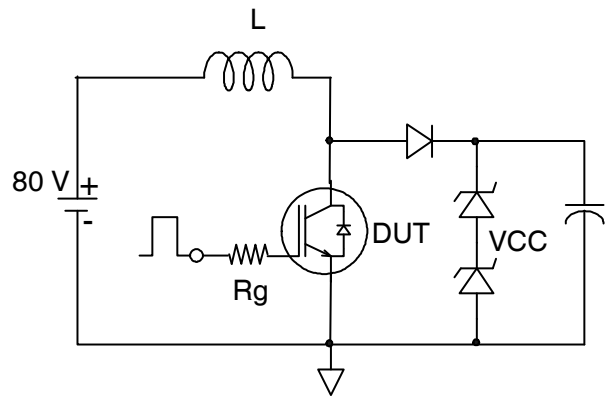
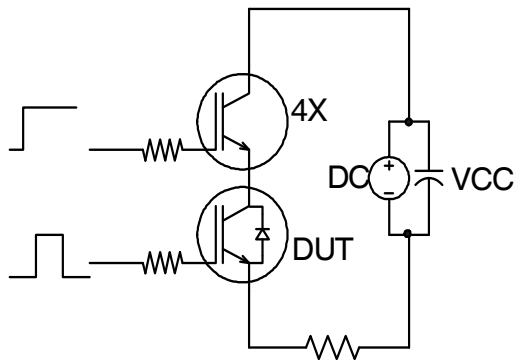
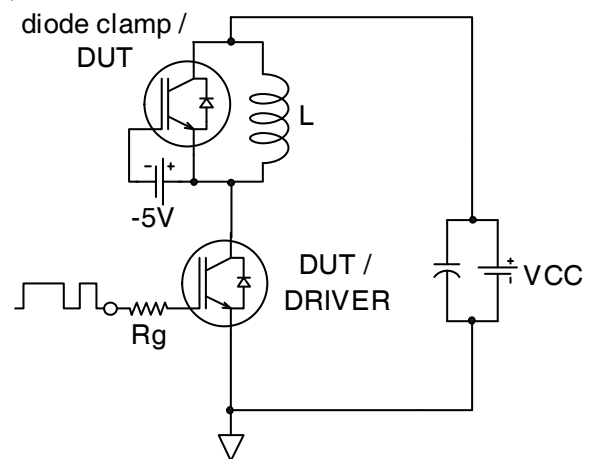
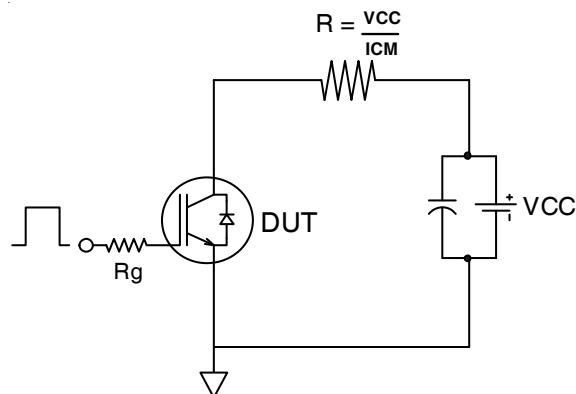

Fig. 27. Maximum Transient Thermal Impedance, Junction-to-Case (DIODE)

Fig.C.T.1 - Gate Charge Circuit (turn-off)

Fig.C.T.2 - RBSOA Circuit

Fig.C.T.3 - S.C. SOA Circuit

Fig.C.T.4 - Switching Loss Circuit

Fig.C.T.5 - Resistive Load Circuit

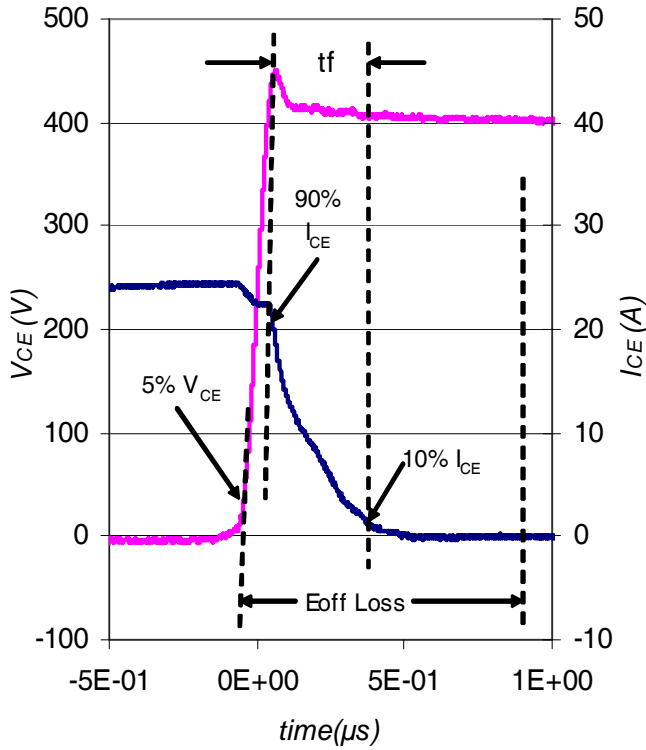

Fig. WF1 - Typ. Turn-off Loss Waveform
@ $T_J = 150^\circ\text{C}$ using Fig. CT.4

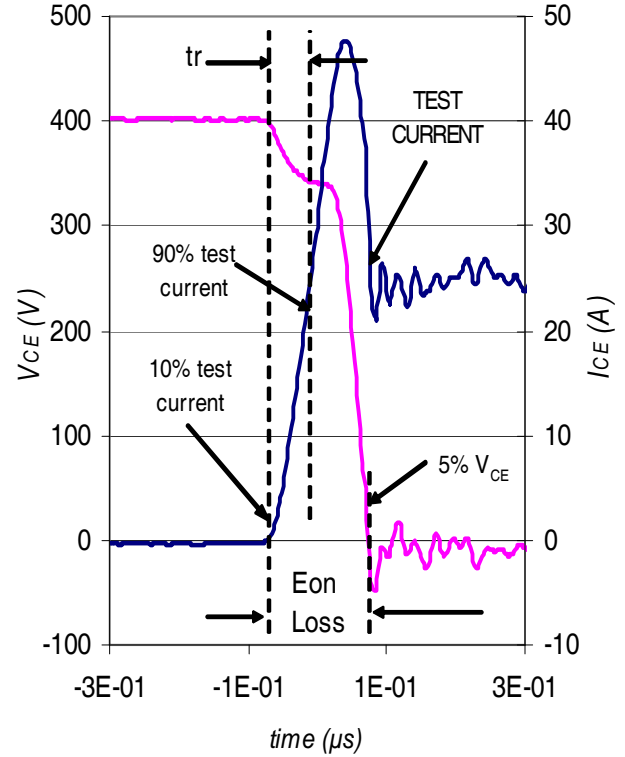

Fig. WF2 - Typ. Turn-on Loss Waveform
@ $T_J = 150^\circ\text{C}$ using Fig. CT.4

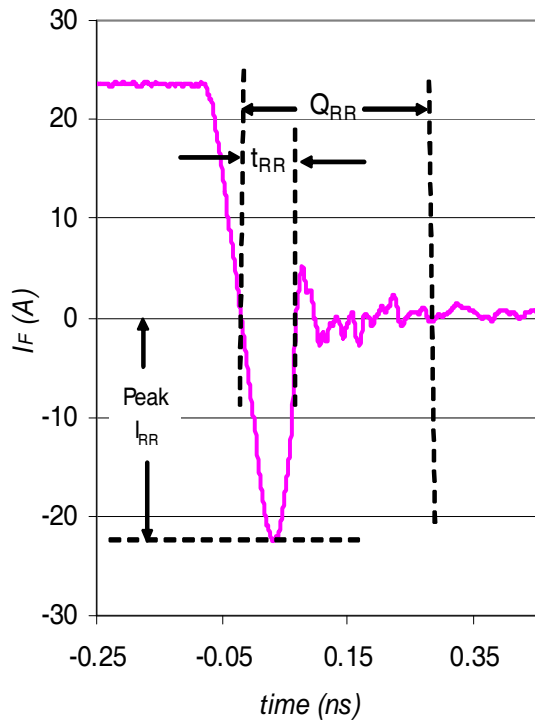

Fig. WF3 - Typ. Diode Recovery Waveform
@ $T_J = 150^\circ\text{C}$ using Fig. CT.4

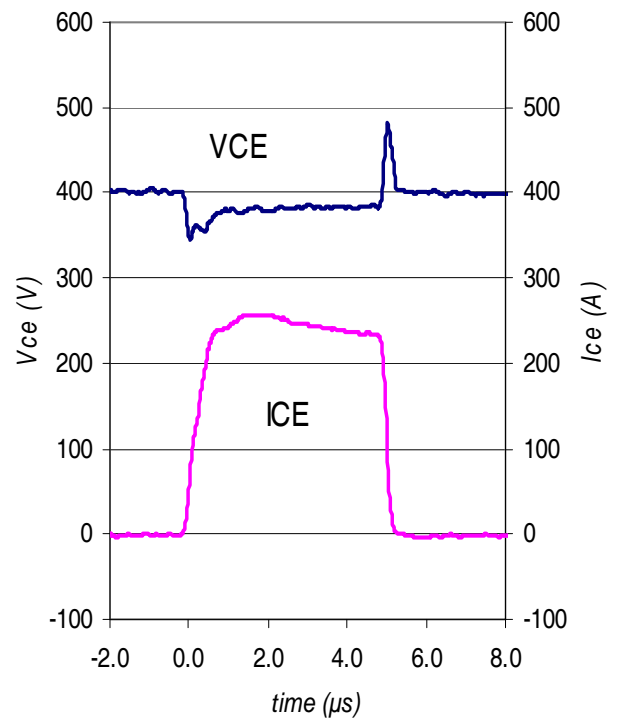
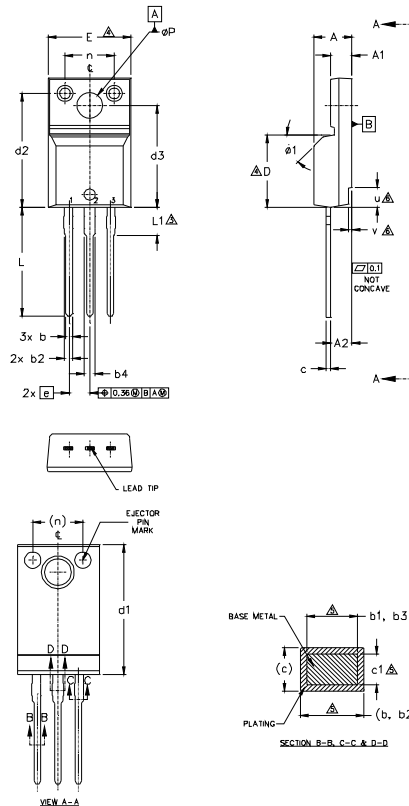

Fig. WF4 - Typ. S.C. Waveform
@ $T_J = 25^\circ\text{C}$ using Fig. CT.3

TO-220AB Full-Pak Package Outline

Dimensions are shown in millimeters (inches)



SYMBOL	DIMENSIONS				NOTES
	MILLIMETERS		INCHES		
	MIN.	MAX.	MIN.	MAX.	
A	4.57	4.83	.180	.190	NOTES: 1.0 DIMENSIONING AND TOLERANCING AS PER ASME Y14.5 M- 1994. 2.0 DIMENSIONS ARE SHOWN IN MILLIMETERS [INCHES]. LEAD DIMENSION AND FINISH UNCONTROLLED IN L1. DIMENSION D & E DO NOT INCLUDE MOLD FLASH. MOLD FLASH SHALL NOT EXCEED .005" (0.127) PER SIDE. THESE DIMENSIONS ARE MEASURED AT THE OUTER MOST EXTREMES OF THE PLASTIC BODY. DIMENSION b1, b3, b5 & c1 APPLY TO BASE METAL ONLY. STEP OPTIONAL ON PLASTIC BODY DEFINED BY DIMENSIONS u & v. 7.0 CONTROLLING DIMENSION : INCHES.
A1	2.57	2.83	.101	.111	
A2	2.51	2.93	.099	.115	
b	0.61	0.94	.024	.037	
b1	0.61	0.89	.024	.035	
b2	0.76	1.27	.030	.050	
b3	0.76	1.22	.030	.048	
b4	1.02	1.52	.040	.060	
b5	1.02	1.47	.040	.058	
c	0.33	0.63	.013	.025	
c1	0.33	0.58	.013	.023	
D	8.66	9.80	.341	.386	
d1	15.80	16.13	.622	.635	
d2	13.97	14.22	.550	.560	
d3	12.30	12.93	.484	.509	
E	9.63	10.75	.379	.423	
e	2.54	BSC	.100	BSC	
L	13.20	13.72	.520	.540	
L1	3.37	3.67	.122	.145	
n	6.05	6.60	.238	.260	
øP	3.05	3.45	.120	.136	
u	2.40	2.50	.094	.098	
v	0.40	0.50	.016	.020	
ø1	-	45°	-	45°	

LEAD ASSIGNMENTS

HEXFET

1.- GATE
2.- DRAIN
3.- SOURCE

IGBTs, CoPACK

1.- GATE
2.- COLLECTOR
3.- EMITTER

TO-220AB Full-Pak Part Marking Information

EXAMPLE: THIS IS AN IRFI840G
WITH ASSEMBLY
LOT CODE 3432
ASSEMBLED ON WW 24, 2001
IN THE ASSEMBLY LINE "K"

Note: "P" in assembly line position indicates "Lead-Free"

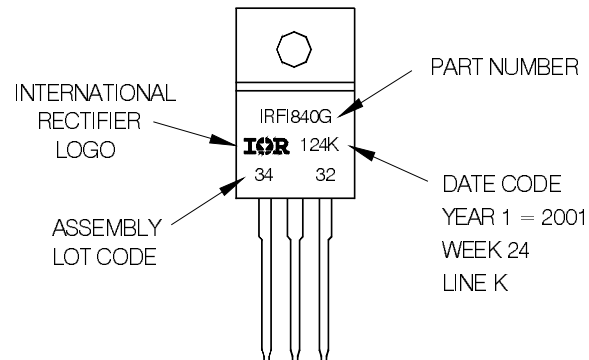

TO-220AB Full-Pak package is not recommended for Surface Mount Application.

Note: For the most current drawing please refer to IR website at <http://www.irf.com/package/>

Data and specifications subject to change without notice.
This product has been designed and qualified for Industrial market.
Qualification Standards can be found on IR's Web site.



IR WORLD HEADQUARTERS: 101 N. Sepulveda Blvd., El Segundo, California 90245, USA Tel: (310) 252-7105
TAC Fax: (310) 252-7903
Visit us at www.irf.com for sales contact information.