

Smart Octal Low-Side Switch



Features

Product Summary

- Short Circuit Protection
- Overtemperature Protection
- Overvoltage Protection
- 16 bit Serial Data Input and Diagnostic Output (2 bit/ch. acc. SPI protocol)
- Direct Parallel Control of Four Channels for PWM Applications
- Parallel Inputs High or Low Active Programmable
- General Fault Flag
- Low Quiescent Current
- Compatible with 3,3 V Micro Controllers
- **E**lectostatic **D**ischarge (ESD) Protection
- Green Product (RoHS compliant)
- AEC Qualified

Supply voltage	V_S	4.5 – 5.5	V
Drain source clamping voltage	$V_{DS(AZ)max}$	55	V
On resistance	R_{ON}	0.75	Ω
Output current(all outp.ON equal) (individually)	$I_{D(NOM)}$	500 1	mA A

Application

- μ C Compatible Power Switch for 12 V and 24V Applications
- Switch for Automotive and Industrial Systems
- Solenoids, Relays and Resistive Loads
- Robotic Controls



General description

Octal Low-Side Switch in Smart Power Technology (SPT) with a **S**erial **P**eripheral **I**nterface (SPI) and eight open drain DMOS output stages. The TLE 6230 GP is protected by embedded protection functions and designed for automotive and industrial applications. The output stages are controlled via an SPI Interface. Additionally four channels can be controlled direct in parallel for PWM applications. Therefore the TLE 6230 GP is particularly suitable for engine management and powertrain systems.

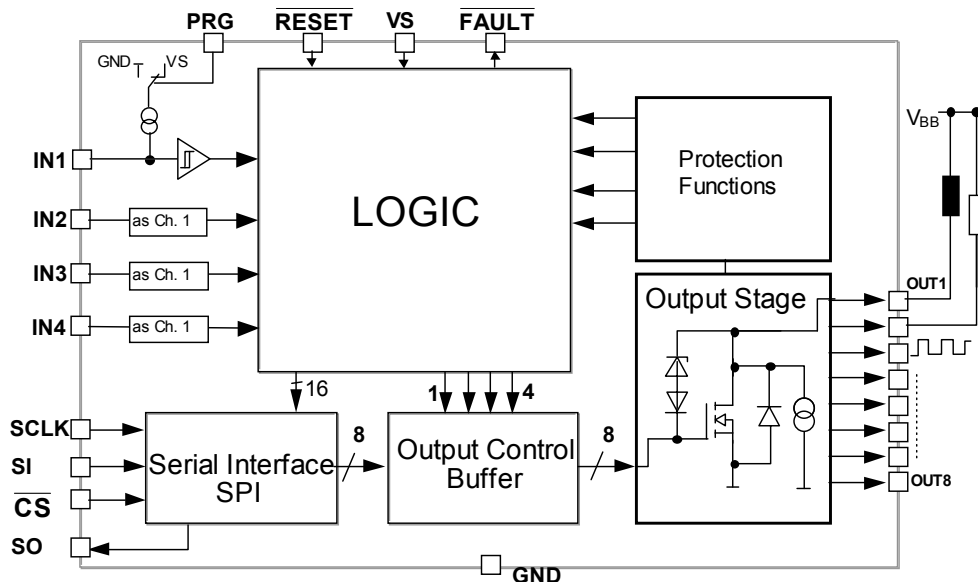

Block Diagram

Detailed Block Diagram

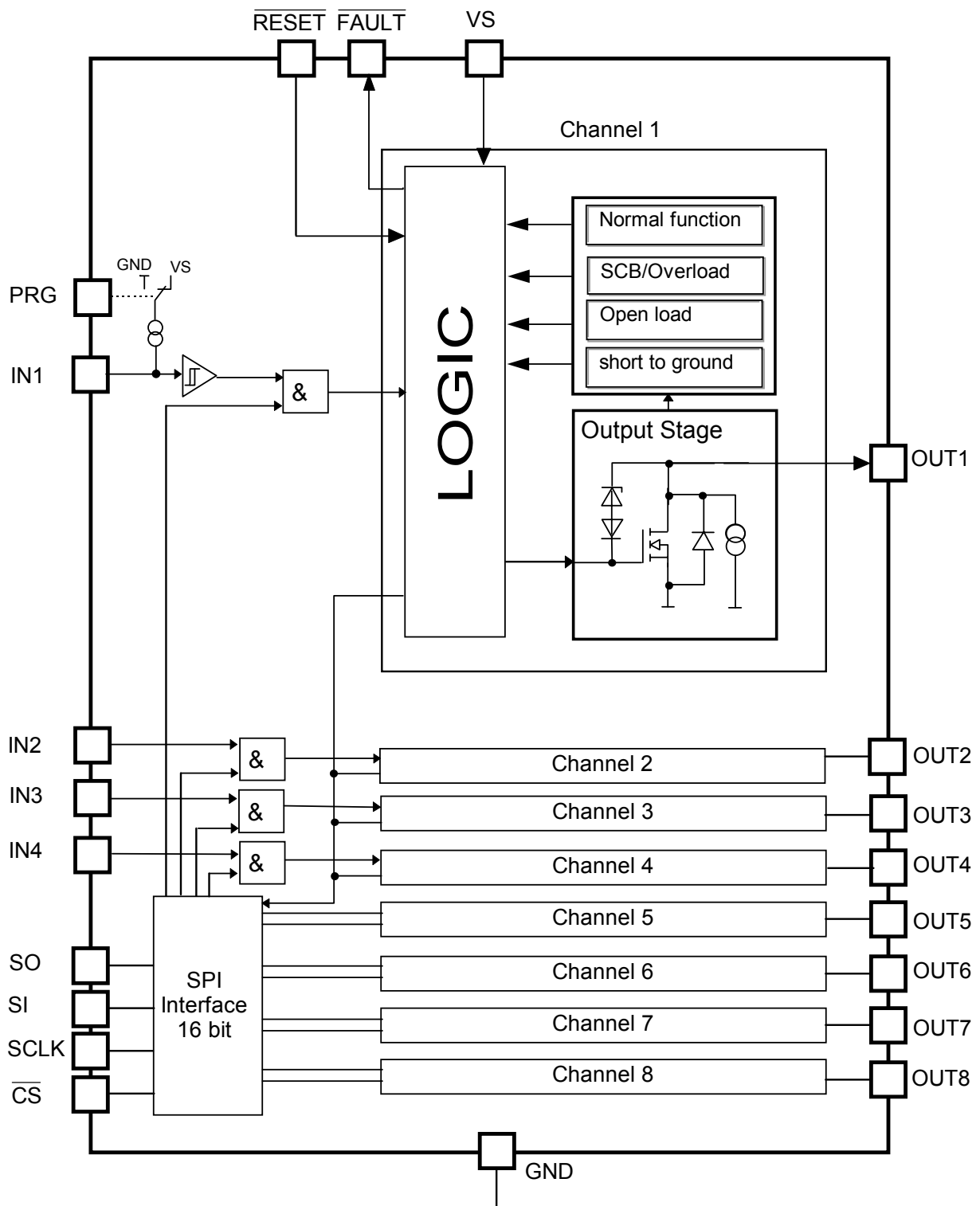

Pin Description

Pin	Symbol	Function
1	GND	Ground
2	NC	not connected
3	NC	not connected
4	OUT1	Power Output Channel 1
5	OUT2	Power Output Channel 2
6	IN1	Input Channel 1
7	IN2	Input Channel 2
8	VS	Supply Voltage
9	RESET	Reset
10	CS	Chip Select
11	PRG	Program (inputs high or low-active)
12	IN3	Input Channel 3
13	IN4	Input Channel 4
14	OUT3	Power Output Channel 3
15	OUT4	Power Output Channel 4
16	NC	not connected
17	NC	not connected
18	GND	Ground
19	GND	Ground
20	NC	not connected
21	NC	not connected
22	OUT5	Power Output Channel 5
23	OUT6	Power Output Channel 6
24	NC	not connected
25	NC	not connected
26	FAULT	General Fault Flag
27	SO	Serial Data Output
28	SCLK	Serial Clock
29	SI	Serial Data Input
30	NC	not connected
31	NC	not connected
32	OUT7	Power Output Channel 7
33	OUT8	Power Output Channel 8
34	NC	not connected
35	NC	not connected
36	GND	Ground

Pin Configuration (Top view)

GND	1 ●	36	GND
NC	2	35	NC
NC	3	34	NC
OUT1	4	33	OUT8
OUT2	5	32	OUT7
IN1	6	31	NC
IN2	7	30	NC
VS	8	29	SI
RESET	9	28	SCLK
CS	10	27	SO
PRG	11	26	FAULT
IN3	12	25	NC
IN4	13	24	NC
OUT3	14	23	OUT6
OUT4	15	22	OUT5
NC	16	21	NC
NC	17	20	NC
GND	18	19	GND

Power SO 36

Heat Slug internally connected to ground pins

Maximum Ratings for $T_j = -40^{\circ}\text{C}$ to 150°C

Parameter	Symbol	Values	Unit
Supply Voltage	V_S	-0.3 ... + 7	V
Continuous Drain Source Voltage (OUT1...OUT8)	V_{DS}	40	V
Input Voltage, All Inputs and Data Lines	V_{IN}	- 0.3 ... + 7	V
Load Dump Protection $V_{Load\ Dump} = U_P + U_S$; $U_P = 13.5\text{ V}$ With Automotive Relay Load $R_L = 70\ \Omega$ $R_l^1) = 2\ \Omega$; $t_d = 400\text{ms}$; IN = low or high With $R_L = 24\ \Omega$; $R_l = 2\ \Omega$; $t_d = 400\text{ms}$; IN = high or low	$V_{Load\ Dump}^{2)}$	80 52	V
Operating Temperature Range	T_j	- 40 ... + 150	$^{\circ}\text{C}$
Storage Temperature Range	T_{stg}	- 55 ... + 150	
Output Current per Channel (see el. characteristics)	$I_{D(lim)}$	$I_{D(lim)\ min}$	A
Output Current per Channel @ $T_A = 25^{\circ}\text{C}$ (All 8 Channels ON; Mounted on PCB) ³⁾	I_D	500	mA
Output Clamping Energy (single pulse) $I_D = 0.5\text{ A}$	E_{AS}	50	mJ
Power Dissipation (mounted on PCB) @ $T_A = 25^{\circ}\text{C}$	P_{tot}	3.3	W
Electrostatic Discharge Voltage (Human Body Model) according to MIL STD 883D, method 3015.7 and EOS/ESD assn. standard S5.1 – 1993			
Output 1-8 Pins	V_{ESD}	2000	V
All other Pins	V_{ESD}	2000	V
DIN Humidity Category, DIN 40 040		E	
IEC Climatic Category, DIN IEC 68-1		40/150/56	
Thermal Resistance			
junction - case	R_{thJC}	5	K/W
junction - ambient @ min. footprint	R_{thJA}	50	
junction - ambient @ 6 cm^2 cooling area with heat pipes		38	

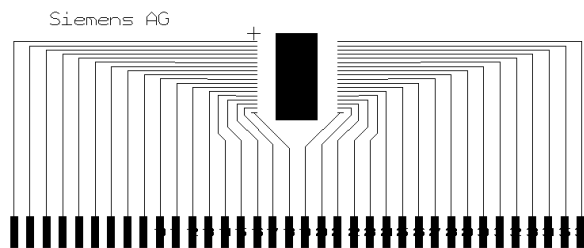

Minimum footprint

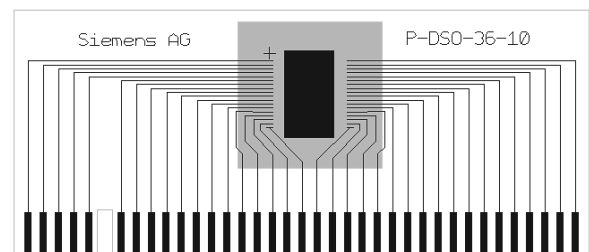
 PCB with heat pipes,
backside 6 cm^2 cooling area

¹⁾ R_l = internal resistance of the load dump test pulse generator LD200

²⁾ $V_{LoadDump}$ is setup without DUT connected to the generator per ISO 7637-1 and DIN 40 839.

³⁾ Output current rating so long as maximum junction temperature is not exceeded. At $T_A = 125^{\circ}\text{C}$ the output current has to be calculated using R_{thJA} according mounting conditions.

Electrical Characteristics

Parameter and Conditions $V_S = 4.5$ to 5.5 V ; $T_J = -40$ °C to $+150$ °C ; Reset = H (unless otherwise specified)	Symbol	Values			Unit
		min	typ	max	

1. Power Supply, Reset

Supply Voltage ⁴	V_S	4.5	--	5.5	V
Supply Current (outputs ON) ⁵	$I_{S(ON)}$	--	1	2	mA
Supply Current (outputs OFF) ⁵	$I_{S(OFF)}$	--	1	2	mA
Minimum Reset Duration	$t_{Reset,min}$	10	--	--	µs

2. Power Outputs

ON Resistance $V_S = 5$ V ; $I_D = 500$ mA	$T_J = 25$ °C $T_J = 150$ °C	$R_{DS(ON)}$	--	0.8 --	1 1.7	Ω
Output Clamping Voltage	Output OFF	$V_{DS(AZ)}$	40	--	55	V
Current Limit		$I_{D(lim)}$	1	1.5	2	A
Output Leakage Current	$V_{Reset} = L$ $V_{bb} = 12$ V	$I_{D(lkg)}$	--	--	5	µA
Turn-On Time	$I_D = 0.5$ A, resistive load	t_{ON}	--	8	12	µs
Turn-Off Time	$I_D = 0.5$ A, resistive load	t_{OFF}	--	6	10	µs

3. Digital Inputs

Input Low Voltage		V_{INL}	- 0.3	--	1.0	V
Input High Voltage		V_{INH}	2.0	--	--	V
Input Voltage Hysteresis		V_{INHys}	50	100	200	mV
Input Pull Down/Up Current (IN1 ... IN4)		$I_{IN(1..4)}$	20	50	100	µA
PRG, Reset Pull Up Current		$I_{IN(PRG,Res)}$	20	50	100	µA
Input Pull Down Current (SI, SCLK)		$I_{IN(SI,SCLK)}$	10	20	50	µA
Input Pull Up Current (CS)		$I_{IN(CS)}$	10	20	50	µA

4. Digital Outputs (SO, FAULT)

SO High State Output Voltage	$I_{SOH} = 2$ mA	V_{SOH}	$V_S - 0.4$	--	--	V
SO Low State Output Voltage	$I_{SOL} = 2.5$ mA	V_{SOL}	--	--	0.4	V
Output Tri-state Leakage Current	$\overline{CS} = H, 0 \leq V_{SO} \leq V_S$	$I_{SO(lkg)}$	-10	0	10	µA
FAULT Output Low Voltage	$I_{FAULT} = 1.6$ mA	V_{FAULTL}	--	--	0.4	V

⁴ For $V_S < 4.5$ V the power stages are switched according the input signals and data bits or are definitely switched off. This undervoltage reset gets active at $V_S = 3$ V (typ. value) and is guaranteed by design.

⁵ For Reset = H.

Electrical Characteristics cont.

Parameter and Conditions	Symbol	Values			Unit
		min	typ	max	
$V_S = 4.5$ to 5.5 V ; $T_j = -40$ °C to $+150$ °C ; Reset = H (unless otherwise specified)					

5. Diagnostic Functions

Open Load Detection Voltage	$V_{DS(OL)}$	$V_S - 2.5$	$V_S - 2$	$V_S - 1.3$	V
Output Pull Down Current	$I_{PD(OL)}$	50	90	150	μA
Fault Delay Time	$t_{d(fault)}$	50	100	200	μs
Short to Ground Detection Voltage	$V_{DS(SHG)}$	$V_S - 3.3$	$V_S - 2.9$	$V_S - 2.5$	V
Short to Ground Detection Current	I_{SHG}	-50	-100	-150	μA
Current Limitation; Overload Threshold Current	$I_{D(lim) 1...8}$	1	1.5	2	A
Overtemperature Shutdown Threshold ⁶	$T_{th(sd)}$	170	--	200	°C
Hysteresis ⁶	T_{hys}	--	10	--	K

6. SPI-Timing

Serial Clock Frequency (depending on SO load)	f_{SCK}	DC	--	5	MHz
Serial Clock Period (1/fclk)	$t_{p(SCK)}$	200	--	--	ns
Serial Clock High Time	t_{SCKH}	50	--	--	ns
Serial Clock Low Time	t_{SCKL}	50	--	--	ns
Enable Lead Time (falling edge of \overline{CS} to rising edge of CLK)	t_{lead}	250	--	--	ns
Enable Lag Time (falling edge of CLK to rising edge of \overline{CS})	t_{lag}	250	---	--	ns
Data Setup Time (required time SI to falling of CLK)	t_{SU}	20	--	--	ns
Data Hold Time (falling edge of CLK to SI)	t_H	20	--	--	ns
Disable Time @ $C_L = 50$ pF ⁶	t_{DIS}	--	--	150	ns
Transfer Delay Time ⁷ (\overline{CS} high time between two accesses)	t_{dt}	200	--	--	ns
Data Valid Time	t_{valid}				
	$C_L = 50$ pF ⁶	--	110	160	ns
	$C_L = 100$ pF ⁶	--	120	170	
	$C_L = 220$ pF ⁶	--	150	200	

⁶ This parameter will not be tested but guaranteed by design

⁷ This time is necessary between two write accesses. To get the correct diagnostic information, the transfer delay time has to be extended to the maximum fault delay time $t_{d(fault)max} = 200\mu s$.

Functional Description

The TLE 6230 GP is an octal-low-side power switch which provides a serial peripheral interface (SPI) to control the 8 power DMOS switches, as well as diagnostic feedback. The power transistors are protected against short to V_{BB} , overload, overtemperature and against over-voltage by an active zener clamp.

The diagnostic logic recognizes a fault condition which can be read out via the serial diagnostic output (SO).

Circuit Description

Output Stage Control

Each output is independently controlled by an output latch and a common reset line, which disables all eight outputs. Serial data input (SI) is read on the falling edge of the serial clock. A logic high input data bit turns the respective output channel ON, a logic low data bit turns it OFF. \overline{CS} must be low whilst shifting all the serial data into the device. A low-to-high transition of \overline{CS} transfers the serial data input bits to the output buffer.

Special conditions for Channel 1 to 4:

In addition to the serial control of the outputs it is possible to control channel 1 to channel 4 directly in parallel for PWM applications. These inputs are high or low active (programmable via PRG pin) and ANDed with the SPI control bit.

The table shows the AND-operation of the parallel input pin (here active high) and the corresponding SPI bit. For an application where the parallel input is always "ON", it is possible to switch the channel OFF via the SPI bit, e.g. for diagnosis in OFF-state.

IN 1 - 4	SPI-Bit 0 - 3	OUT 1 - 4
0	0	OFF
0	1	OFF
1	0	OFF
1	1	ON

⇒ SPI Priority for OFF-state

Operation with parallel inputs: Set SPI bits to logic high.

Operation via SPI: Connect parallel inputs to logic high (if programmed to active high).

PRG - Program pin. PRG = High (V_S): Parallel inputs Channel 1 to 4 are high active

PRG = Low (GND): Parallel inputs Channel 1 to 4 are low active.

If the parallel input pins are not connected (independent of high or low activity) it is guaranteed that the channels 1 to 4 are switched OFF.

PRG pin itself is internally pulled up when it is not connected.

Power Transistor Protection Functions⁸⁾

Each of the eight output stages has its own zener clamp, which causes a voltage limitation at the power transistor when solenoid loads are switched off. The outputs are provided with a current limitation set to a minimum of 1 A. The continuous current for each channel is 500 mA (all channels ON).

Each output is protected by embedded protection functions. In the event of an overload or short to supply, the current is internally limited and the corresponding bit combination is set (early warning). If this operation leads to an overtemperature condition, a second protection level (about 170 °C) will change the output into a low duty cycle PWM (selective thermal shut-down with restart) to prevent critical chip temperatures.

SPI Signal Description

\overline{CS} - Chip Select. The system microcontroller selects the TLE 6230 GP by means of the \overline{CS} pin. Whenever the pin is in a logic low state, data can be transferred from the μC and vice versa.

\overline{CS} High to Low transition:  - diagnostic status information is transferred from the power outputs into the shift register.
 - serial input data can be clocked in from then on
 - SO changes from high impedance state to logic high or low state corresponding to the SO bits

\overline{CS} Low to High transition:  - transfer of SI bits from shift register into output buffers
 - reset of diagnosis register

To avoid any false clocking the serial clock input pin SCLK should be logic low state during high to low transition of \overline{CS} . When \overline{CS} is in a logic high state, any signals at the SCLK and SI pins are ignored and SO is forced into a high impedance state.

SCLK - Serial Clock. The system clock pin clocks the internal shift register of the TLE 6230 GP. The serial input (SI) accepts data into the input shift register on the falling edge of SCLK while the serial output (SO) shifts diagnostic information out of the shift register on the rising edge of serial clock. It is essential that the SCLK pin is in a logic low state whenever chip select \overline{CS} makes any transition. The number of clock pulses will be counted during a chip select cycle. The received data will only be accepted, if exactly 16 clock pulses were counted during \overline{CS} is active.

SI - Serial Input. Serial data bits are shifted in at this pin, the most significant bit first. SI information is read in on the falling edge of SCLK. Input data is latched in the shift register and then transferred to the control buffer of the output stages.

The input data consists of two bytes - a "control byte" followed by a "data byte". The control byte contains the information as to whether the data byte will be accepted or ignored (see diagnostics section). The data byte contains the input information for the eight channels. A logic

⁸⁾ The integrated protection functions prevent an IC destruction under fault conditions and may not be used in normal operation or permanently

high level at this pin (within the data byte) will switch on the power switch, provided that the corresponding parallel input is also switched on (AND-operation for channel 1 to 4).

SO - Serial Output. Diagnostic data bits are shifted out serially at this pin, the most significant bit first. SO is in a high impedance state until the \overline{CS} pin goes to a logic low state. New diagnostic data will appear at the SO pin following the rising edge of SCLK.

RESET - Reset pin. If the reset pin is in a logic low state, it clears the SPI shift register and switches all outputs OFF. An internal pull-up structure is provided on chip.

Diagnostics

FAULT - Fault pin. There is a general fault pin (open drain) which shows a high to low transition as soon as an error occurs for any one of the eight channels. This fault indication can be used to generate a μC interrupt. Therefore a 'diagnosis' interrupt routine need only be called after this fault indication. This saves processor time compared to a cyclic reading of the SO information.

As soon as a fault occurs, the fault information is latched into the diagnosis register. A new error will over-write the old error report. Serial data out pin (SO) is in a high impedance state when \overline{CS} is high. If \overline{CS} receives a LOW signal, all diagnosis bits can be shifted out serially. The rising edge of \overline{CS} will reset all error registers.

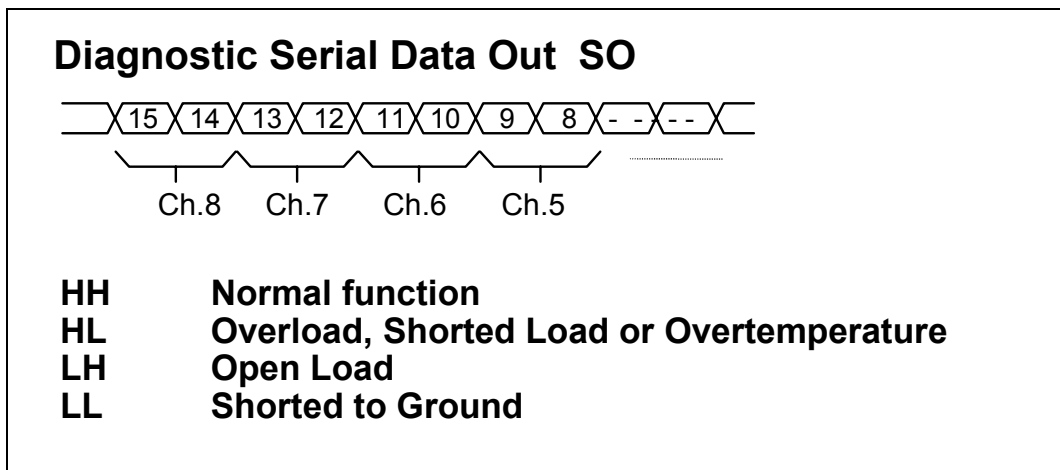

Figure 1: Two bits per channel diagnostic feedback

There are two diagnostic bits per channel configured as shown in Figure 1.

Normal function: The bit combination **HH** indicates that there is no fault condition, i.e. normal function.

Overload, Short Circuit to Battery (SCB) or Overtemperature: **HL** is set when the current limitation gets active, i.e. there is a overload, short to supply or overtemperature condition.

Open load: An open load condition is detected when the drain voltage decreases below 3 V (typ.). **LH** bit combination is set.

Short Circuit to GND: If a drain to ground short circuit exists and the drain to ground current exceeds 100 μA , short to ground is detected and the **LL** bit combination is set.

A definite distinction between open load and short to ground is guaranteed by design.

The standard way of obtaining diagnostic information is as follows:

Clock in serial information into SI pin and wait approximately 150 μ s to allow the outputs to settle. Clock in the identical serial information once again - during this process the data coming out at SO contains the bit combinations representing the diagnosis conditions as described in figure 1.

By means of the control byte it is possible either to:

- a) control the eight outputs according to the data byte, as well as being able to read the diagnostic information
- or b) purely get diagnostic information without changing the state of the outputs.

a) Serial Control of Outputs

HHHHHHHH LHLHLLL : Serial input information

Control Byte Data Byte

Control byte is set to FFhex: Data byte will be accepted. The outputs will be switched ON or OFF according to the information of the data byte and the parallel inputs (Channel 1 to 4 because of AND operation).

All other control words except the one for 'Diagnosis Only = 00hex' will also be accepted as a valid control word and the data will be accepted.

Example: HLLHLHLH DDDDDDDD: Outputs will switch according to the data bits.

b) Diagnosis Only

LLLLLLLL XXXXXXXX : Serial input information

Control Byte Data Byte

Control byte is set to 00hex: Data byte will be ignored. Diagnostic information can be read out at any time with no change of the switching conditions. Only 00hex means 'Diagnosis Only'.

Timing Diagrams

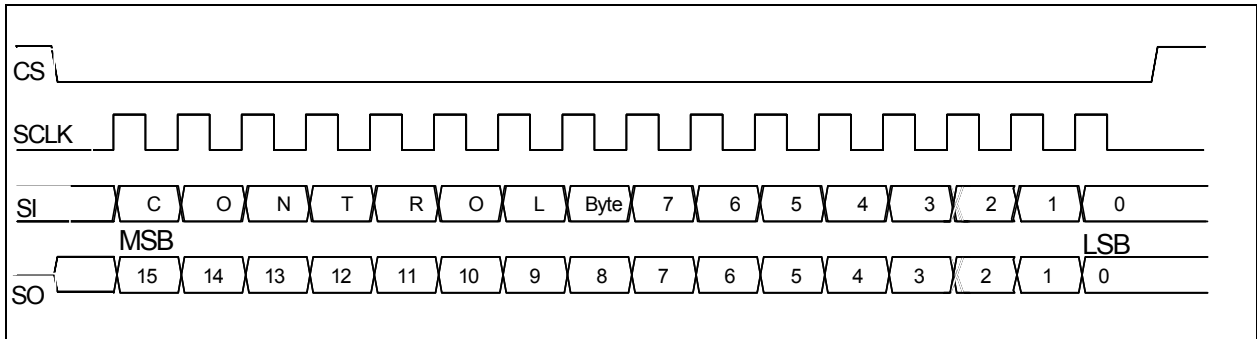

Figure 2: Serial Interface

Figure 3: Input Timing Diagram

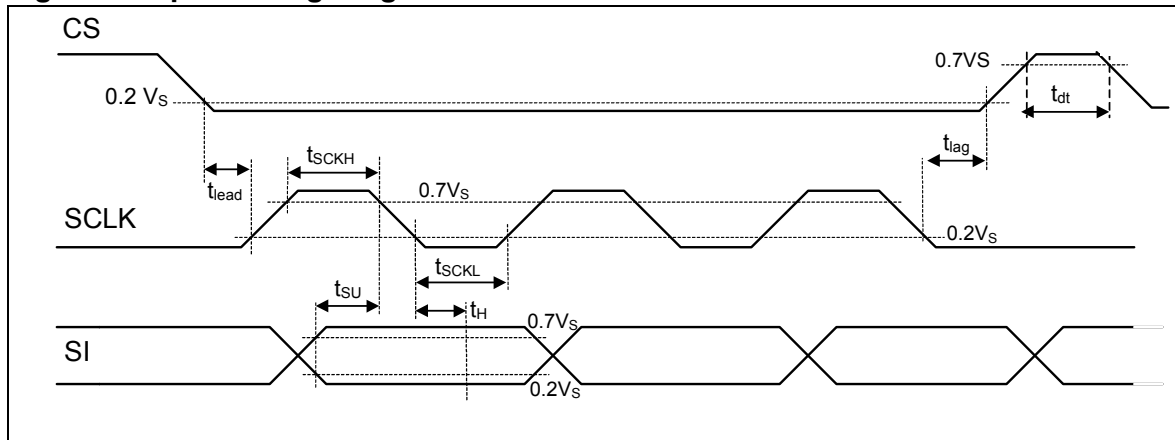
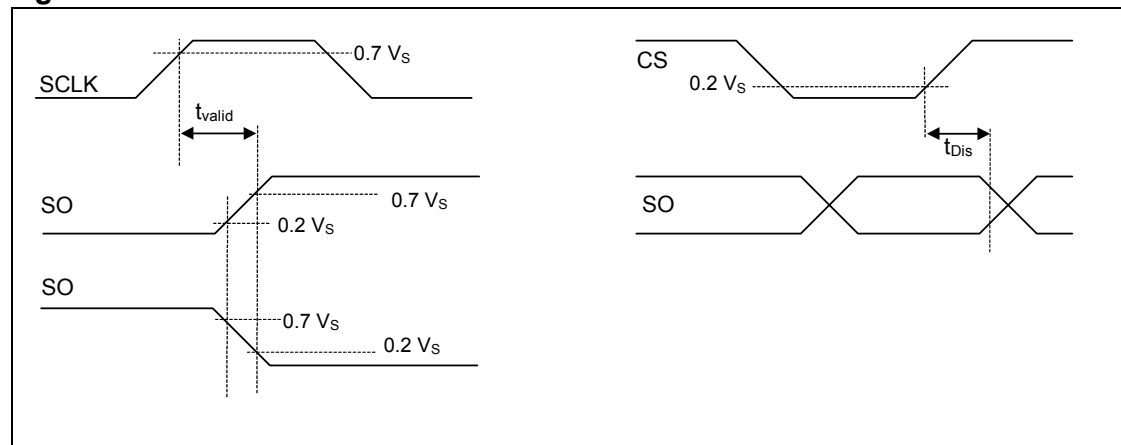

Figure 4:



SO Valid Time Waveforms

Enable and Disable Time Waveforms

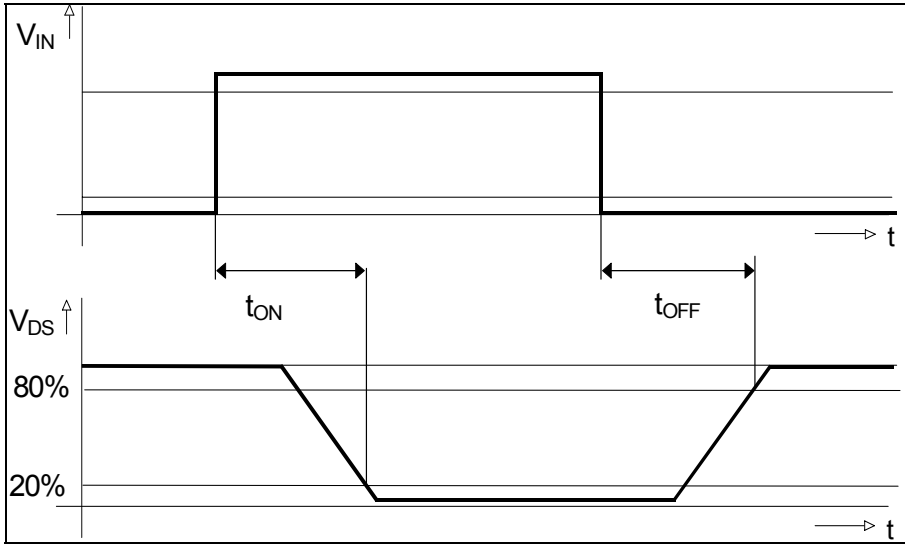
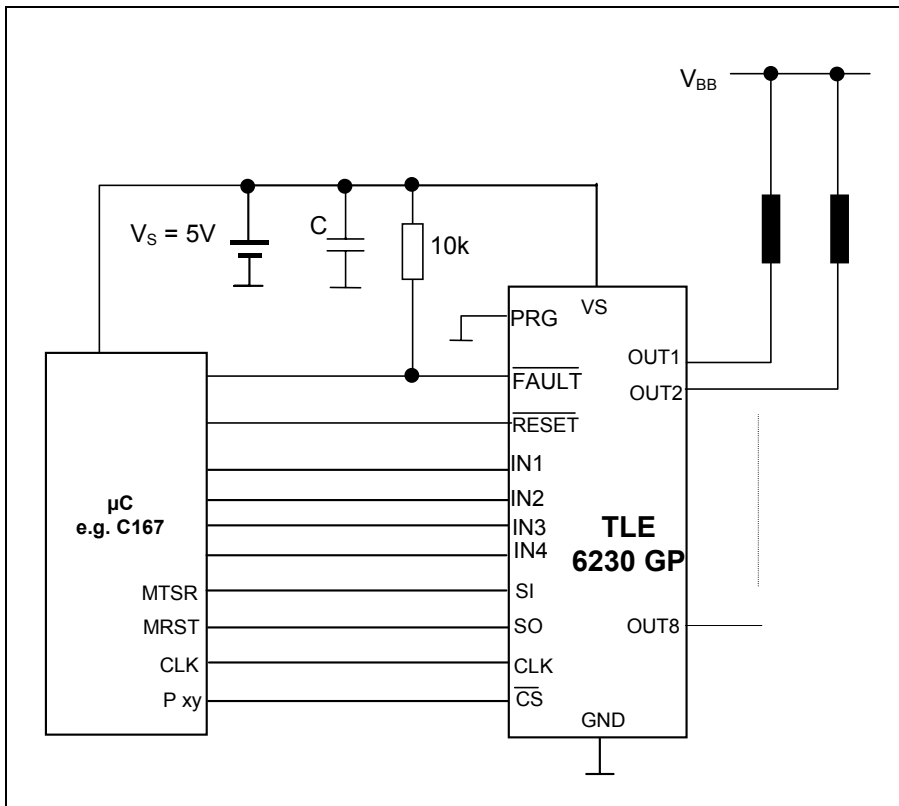

Figure 5: Power Outputs

Timing is valid for resistive load with parallel and serial control.
 Rising edge of chip select initiates the switching

Application Circuits



Typical electrical Characteristics

Drain-Source on-resistance

$$R_{DS(ON)} = f(T_j) ; V_s = 5V$$

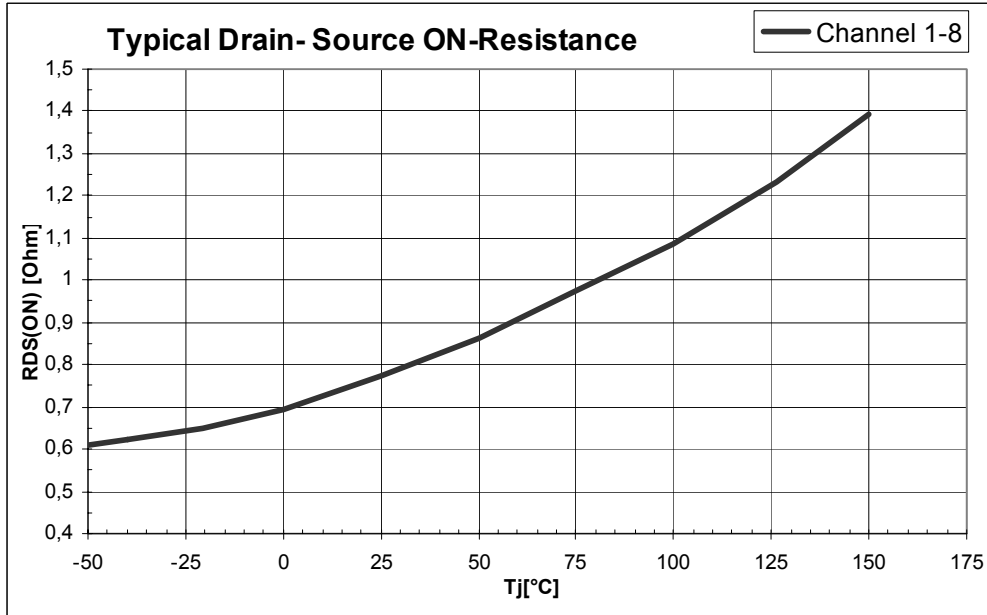

Figure 6 : Typical ON Resistance versus Junction-Temperature
Channel 1-8

Output Clamping Voltage

$$V_{DS(AZ)} = f(T_j) ; V_s = 5V$$

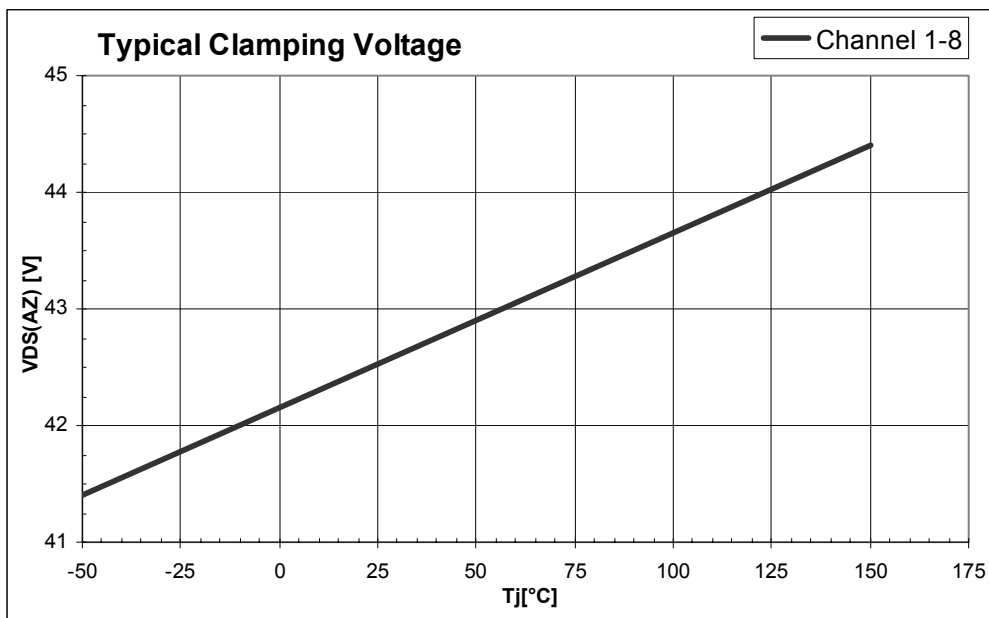

Figure 7 : Typical Clamp Voltage versus Junction-Temperature
Channel 1-8

Maximum single clamp Energy

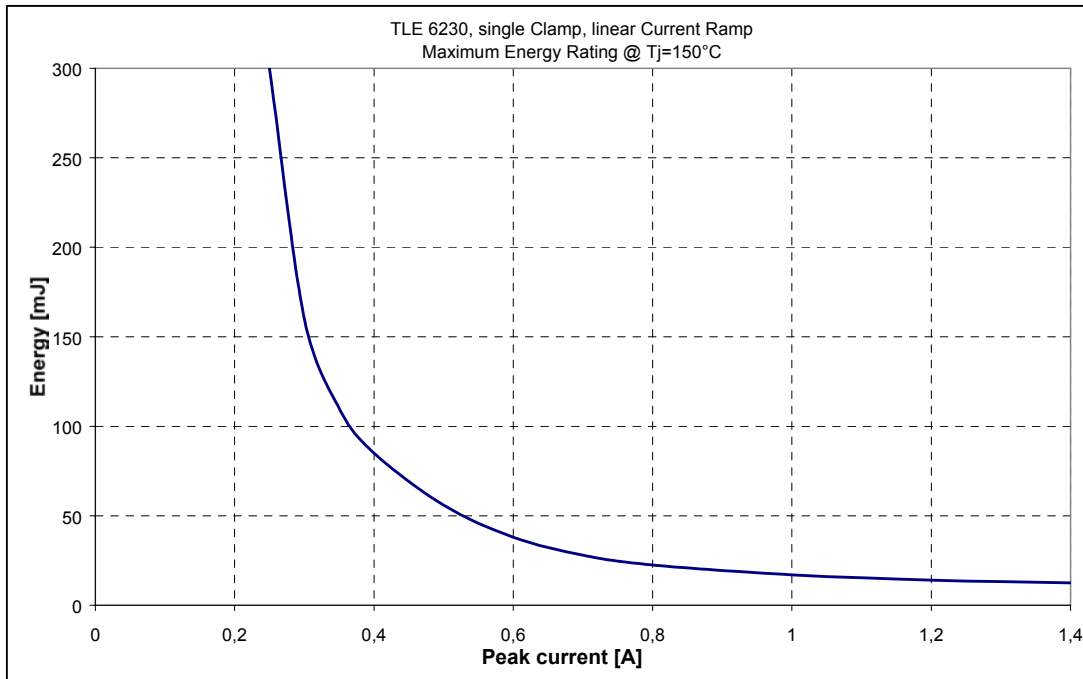
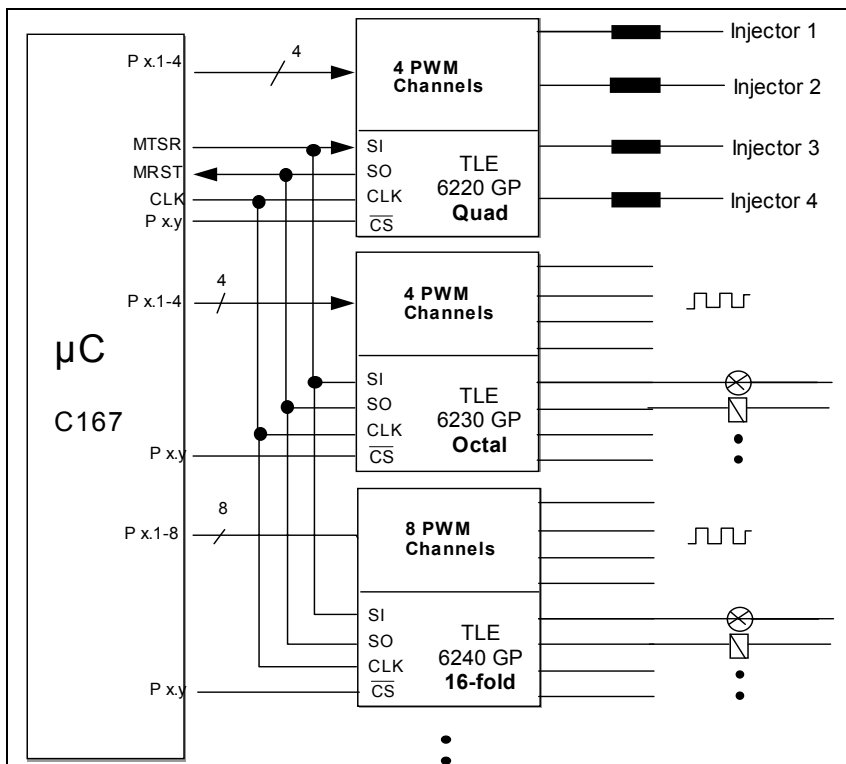

Figure 8 : Maximum Clamp Energy (single event) versus Peak Current Channel 1-8

Parallel SPI Configuration



Engine Management Application

TLE 6230 GP in combination with TLE 6240 GP (16-fold switch) for relays and general purpose loads and TLE 6220 GP (quad switch) to drive the injector valves. This arrangement covers the numerous loads to be driven in a modern Engine Management/Powertrain system. From 28 channels in sum 16 can be controlled direct in parallel for PWM applications.

Package and Ordering Code

(all dimensions in mm)

PG-DSO 36

TLE 6230 GP

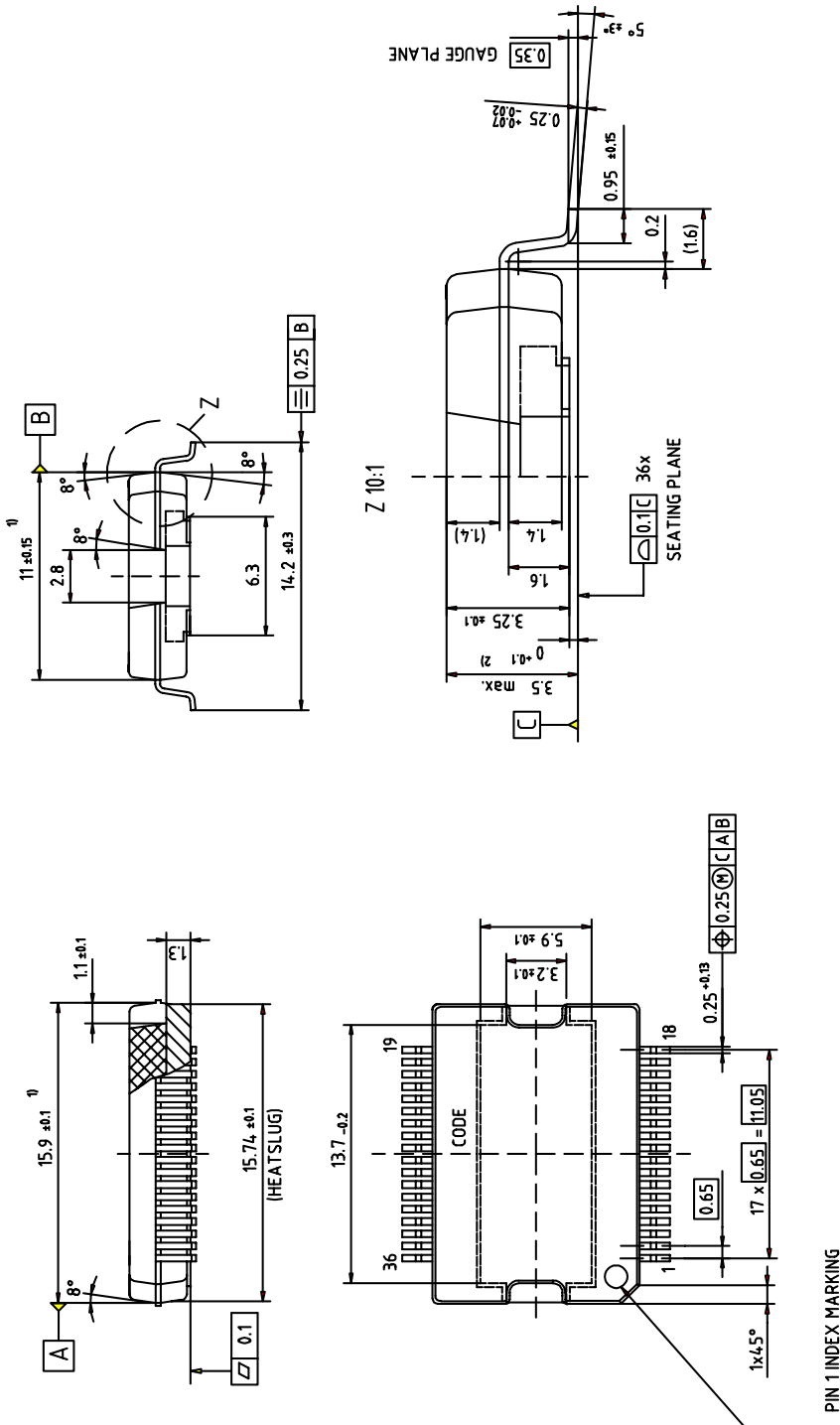

Edition 2008-04-17

Published by

Infineon Technologies AG

81726 Munich, Germany

© 2008 Infineon Technologies AG

All Rights Reserved.

Legal Disclaimer

The information given in this document shall in no event be regarded as a guarantee of conditions or characteristics. With respect to any examples or hints given herein, any typical values stated herein and/or any information regarding the application of the device, Infineon Technologies hereby disclaims any and all warranties and liabilities of any kind, including without limitation, warranties of non-infringement of intellectual property rights of any third party.

Information

For further information on technology, delivery terms and conditions and prices, please contact the nearest Infineon Technologies Office (www.infineon.com).

Warnings

Due to technical requirements, components may contain dangerous substances. For information on the types in question, please contact the nearest Infineon Technologies Office.

Infineon Technologies components may be used in life-support devices or systems only with the express written approval of Infineon Technologies, if a failure of such components can reasonably be expected to cause the failure of that life-support device or system or to affect the safety or effectiveness of that device or system. Life support devices or systems are intended to be implanted in the human body or to support and/or maintain and sustain and/or protect human life. If they fail, it is reasonable to assume that the health of the user or other persons may be endangered.