

**Major Ratings and Characteristics**

Characteristics	Limits	Units
$I_{F(AV)}$ Rectangular Waveform	15	A
$V_{RRM}$	100	V
$I_{FSM}$ @ $t_p = 8.3ms$ half-sine	250	A
$V_F$ @ 15Apk, $T_J = 125^\circ C$	0.72	V
$T_J, T_{stg}$ Operating and Storage	-65 to 150	$^\circ C$

**Description/Features**

The 1N6844U3 Schottky rectifier has been expressly designed to meet the rigorous requirements of high reliability environments. It is packaged in the hermetic surface mount SMD-0.5 ceramic package. The device's forward voltage drop and reverse leakage current are optimized for the lowest power loss and the highest circuit efficiency for typical high frequency switching power supplies and resonant power converters. Full MIL-PRF-19500 quality conformance testing is available on source controlled drawings to S, TX and TXV levels.

- Hermetically Sealed
- Low Forward Voltage Drop
- High Frequency Operation
- Guard Ring for Enhanced Ruggedness and Long Term Reliability
- Surface Mount
- Lightweight
- ESD Rating: Class NS per MIL-STD-750, Method 1020

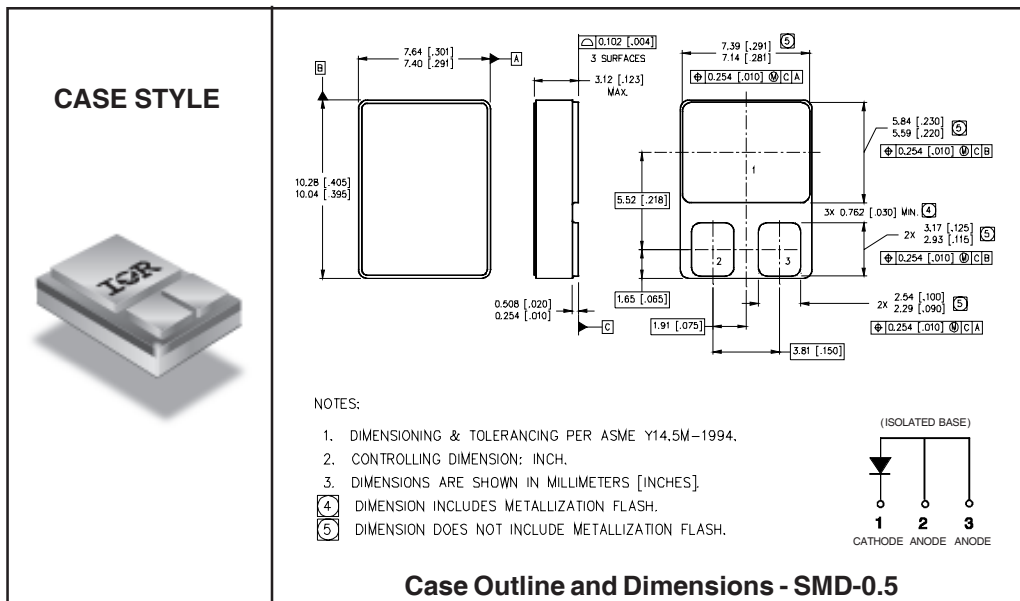

**Voltage Ratings**

Part number	1N6844U3
$V_R$ Max. DC Reverse Voltage (V)	100
$V_{RWM}$ Max. Working Peak Reverse Voltage (V)	

**Absolute Maximum Ratings**

Parameters	Limits	Units	Conditions
$I_{F(AV)}$ Max. Average Forward Current See Fig. 5	15	A	50% duty cycle @ $T_C = 125^\circ\text{C}$ , rectangular waveform
$I_{FSM}$ Max. Peak One Cycle Non - Repetitive Surge Current	250	A	@ $t_p = 8.3$ ms half-sine

**Electrical Specifications**

Parameters	Limits	Units	Conditions
$V_{FM}$ Max. Forward Voltage Drop See Fig. 1 ①	0.70	V	@ 5.0A
	0.90	V	@ 15A
	1.0	V	@ 20A
	0.58	V	@ 5.0A
	0.72	V	@ 15A
	0.85	V	@ 5.0A
$I_{RM}$ Max. Reverse Leakage Current See Fig. 2 ①	50	$\mu\text{A}$	$T_J = 25^\circ\text{C}$
	10	$\text{mA}$	$T_J = 125^\circ\text{C}$
$C_T$ Max. Junction Capacitance	600	$\text{pF}$	$V_R = 5V_{DC}$ ( 1MHz, $25^\circ\text{C}$ )
$L_S$ Typical Series Inductance	4.8	$\text{nH}$	Measured from center of cathode pad to center of anode pad

**Thermal-Mechanical Specifications**

Parameters	Limits	Units	Conditions
$T_J$ Max. Junction Temperature Range	-65 to 150	$^\circ\text{C}$	
$T_{stg}$ Max. Storage Temperature Range	-65 to 150	$^\circ\text{C}$	
$R_{thJC}$ Max. Thermal Resistance, Junction to Case	2.0	$^\circ\text{C}/\text{W}$	DC operation See Fig. 4
wt Weight (Typical)	1.0	g	
Die Size	125X125	mils	
Case Style	SMD-0.5		

① Pulse Width < 300 $\mu\text{s}$ , Duty Cycle < 2%

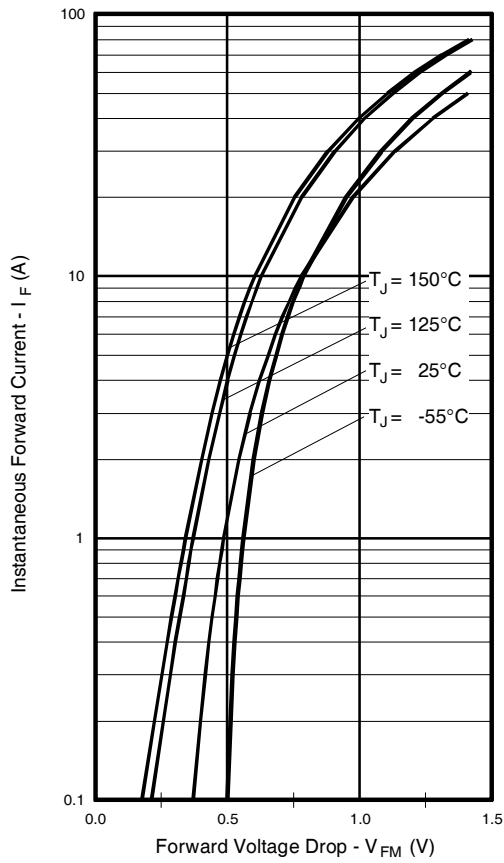

Fig. 1 - Max. Forward Voltage Drop Characteristics

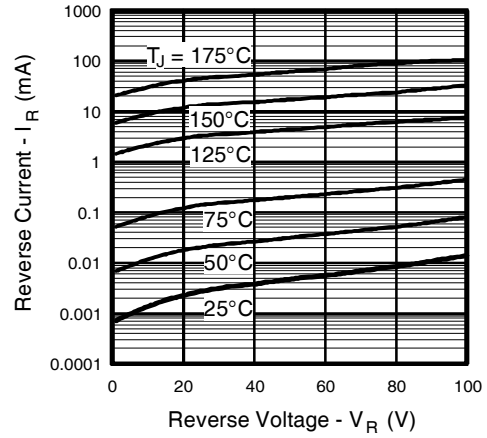

Fig. 2 - Typical Values of Reverse Current Vs. Reverse Voltage

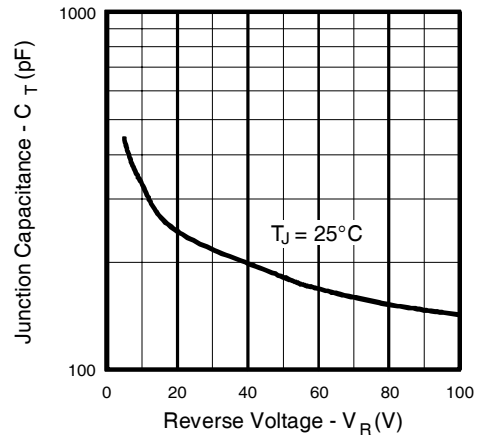

Fig. 3 - Typical Junction Capacitance Vs. Reverse Voltage

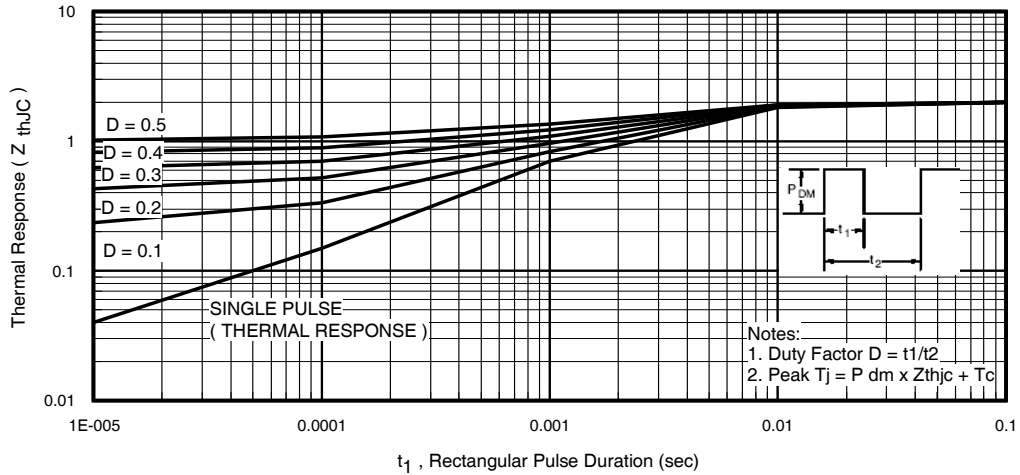

Fig. 4 - Max. Thermal Impedance  $Z_{thJC}$  Characteristics

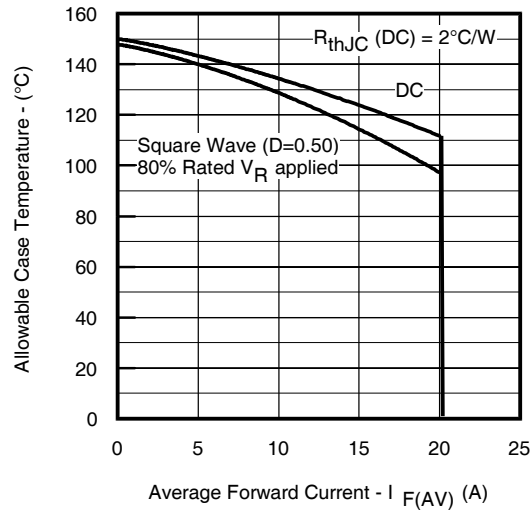

Fig. 5 - Max. Allowable Case Temperature Vs. Average Forward Current