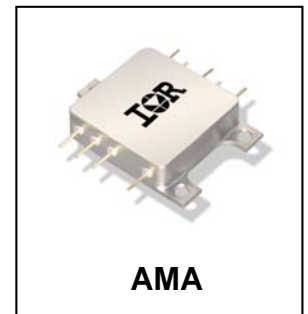

**HYBRID-HIGH RELIABILITY  
RADIATION TOLERANT  
DC-DC CONVERTER****28V Input, Single Output****Description**

The AMA28XXS Series of DC-DC converter module has been specifically designed for operation in moderate radiation environments supplementing the higher radiation performance available in the IR HiRel ART2815T converter series. Environments presented to space vehicles operating in low earth orbits, launch boosters, orbiting space stations and similar applications requiring a low power, high performance converter with moderate radiation hardness performance will be optimally served by the AMA28XXS Series.

The physical configuration of the AMA28XXS Series permits mounting directly to a heat conduction surface without the necessity of signal leads penetrating the heat sink surface. This package configuration permits greater independence in mounting and more mechanical security than traditional packages. International Rectifier's rugged ceramic seal pins are used exclusively in the package thereby assuring long term hermeticity.

The AMA28XXS has been designed for high density using chip and wire hybrid technology that complies with the class H requirements of MIL-PRF-38534. Manufactured in a facility fully qualified to MIL-PRF-38534, these converters are fabricated utilizing DLA qualified processes. For available screening options, refer to device screening table in the data sheet. Applicable generic lot qualification test data including radiation performance can be made available on request. Variations to the standard screening can be accommodated. Consult IR HiRel San Jose for special requirements.

**Features**

- 5.0 Watts Output Power
- Available in 5, 12 and 15 Volt Outputs
- 16- 40 V<sub>DC</sub> Input Range (28 V<sub>DC</sub> Nominal)
- Total Ionizing Dose > 25 kRads(Si)
- SEE Hardened to LET up to 60 MeV·cm<sup>2</sup>/mg
- -55°C to +125°C Operating Range
- Indefinite Short Circuit Protection
- Flexible Mounting
- Fully Isolated - Input to Output and to Case
- Complimentary EMI Filter Available
- Electrical Performance Similar to ASA28XXS Series
- Standard Microcircuit Drawings Available

## Specifications

Absolute Maximum Ratings		Recommended Operating Conditions	
Input Voltage range	-0.5V <sub>DC</sub> to +50V <sub>DC</sub> (Continuous), 80V (100ms)	Input Voltage range	+16V <sub>DC</sub> to +40V <sub>DC</sub>
Soldering temperature	300°C for 10 seconds	Output power	Less than or equal to 5W
Storage case temperature	-65°C to +135°C	Operating temperature	-55°C to +125°C

**Static Characteristics**  $-55^{\circ}\text{C} \leq T_{\text{CASE}} \leq +125^{\circ}\text{C}$ ,  $V_{\text{IN}} = 28\text{V}_{\text{DC}} \pm 5\%$ ,  $C_{\text{L}} = 0$ , unless otherwise specified.

Parameter	Group A Subgroups	Test Conditions	Min	Nom	Max	Unit
Input Voltage			16	28	40	V
Output Voltage		$I_{\text{OUT}} = 0$				
AMA2805S	1		4.95	5.00	5.05	V
AMA2812S	1		11.88	12.00	12.12	
AMA2815S	1		14.85	15.00	15.15	
AMA2805S	2, 3		4.90		5.10	
AMA2812S	2, 3		11.76		12.24	
AMA2815S	2, 3		14.70		15.30	
Output Current <sup>1</sup>		$V_{\text{IN}} = 16, 28, 40$ Volts				
AMA2805S	1, 2, 3				1000	mA
AMA2812S	1, 2, 3				417	
AMA2815S	1, 2, 3				333	
Output Power <sup>1</sup>		$V_{\text{IN}} = 28$ Volts, 100% load			5.0	W
Output Ripple Voltage <sup>2</sup>		$V_{\text{IN}} = 16, 28, 40$ Volts 100% Load BW = 20 Hz to 2.0 MHz				
AMA2805S	1, 2, 3				200	mV <sub>PP</sub>
AMA2812S	1, 2, 3				200	
AMA2815S	1, 2, 3				200	
Output Voltage Regulation		$V_{\text{IN}} = 16, 28, 40$ Volts $I_{\text{OUT}} = 0, 50\%$ , and 100% load				
Line	1, 2, 3			±10	±50	mV
Load	1, 2, 3			±10	±50	

For Notes to Electrical Performance Characteristics, refer to page 4

**Static Characteristics** (continued)  $-55^{\circ}\text{C} \leq T_{\text{CASE}} \leq +125^{\circ}\text{C}$ ,  $V_{\text{IN}} = 28\text{V}_{\text{DC}} \pm 5\%$ ,  $C_{\text{L}} = 0$ , unless otherwise specified.

Parameter	Group A Subgroups	Test Conditions	Min	Nom	Max	Unit	
Input Current	No Load	$V_{\text{IN}} = 28\text{V}$ , $I_{\text{OUT}} = 0$ , Inhibit (pin 5) = open		20	50	mA	
	Inhibit	Inhibit (pin 5) shorted to Input return (pin 7)		8.0	12		
Input Ripple Current <sup>2</sup>	1, 2, 3	$V_{\text{IN}} = 16, 28, 40$ Volts, 100% load, BW = 20 Hz to 2.0 MHz			100	mA <sub>P-P</sub>	
Efficiency	AMA2805S	100% load	66			%	
	AMA2812S		71				
	AMA2815S		71				
	AMA2805S		2	66			
	AMA2812S		2	68			
	AMA2815S		2	68			
Isolation	1	Input to output or any pin to case (except pin 8) at 500Vdc	100			MΩ	
Capacitive Load <sup>3,4</sup>	AMA2805S	No effect on dc performance			500	μF	
	AMA2812S				100		
	AMA2815S				100		
Short Circuit Power Dissipation	1, 2, 3				4.0	W	
MTBF		MIL-HDBK-217F, SF @ 35°C	700			kHrs	
Weight					32	g	

For Notes to Electrical Performance Characteristics, refer to page 4

**Dynamic Characteristics**  $-55^{\circ}\text{C} \leq T_{\text{CASE}} \leq +125^{\circ}\text{C}$ ,  $V_{\text{IN}} = 28\text{V}_{\text{DC}} \pm 5\%$ ,  $C_{\text{L}} = 0$ , unless otherwise specified.

Parameter	Group A Subgroups	Test Conditions	Min	Nom	Max	Unit
Short Circuit Recovery <sup>4</sup>	4, 5, 6	0% load to 100% load			25	ms
Switching Frequency	4, 5, 6	100% load	500	550	600	kHz
Output Response To Step Transient Load Changes <sup>8</sup>	4, 5, 6	Load step 50% $\leftrightarrow$ 100%	-450		+450	mVpk
	4, 5, 6	Load step 0% $\leftrightarrow$ 50%	-750		+750	
Recovery Time, Step Transient Load Changes <sup>5, 6</sup>	AMA2805S	Load step 50% $\leftrightarrow$ 100%			300	ms
	AMA2812S				100	
	AMA2815S				100	
	AMA2805S	Load step 0% $\leftrightarrow$ 50%			2000	
	AMA2812S				2000	
	AMA2815S				2000	
Output Response Transient Step Line Changes <sup>4, 7</sup>	AMA2805S	Input step 16 $\leftrightarrow$ 40Vdc, 100% load	-550		+550	mVpk
	AMA2812S		-750		+750	
	AMA2815S		-750		+750	
Recovery Time Transient Step Line Changes <sup>4, 6, 7</sup>	4, 5, 6	Input step 16 $\leftrightarrow$ 40Vdc, 100% load			1200	ms
Turn On Overshoot <sup>8</sup>	AMA2805S	0% to 100% load			600	mVpk
Turn On Overshoot <sup>8</sup>	AMA2812S	0% to 100% load			600	mVpk
	AMA2815S				400	
Turn On Delay <sup>8</sup>	4, 5, 6	0% load to 100% load			25	ms

### Notes to Specifications

- Parameter guaranteed by line and load regulation tests.
- Bandwidth guaranteed by design. Tested for 20 kHz to 2.0MHz.
- Capacitive value may be any value from 0 to the maximum limit without compromising DC performance. A capacitive load in excess of the maximum limit will not disturb loop stability but may interfere with the operation of the load fault detection circuitry, appearing as a short circuit during turn-on.
- Parameter shall be tested as part of design characterization and after design or process changes. Thereafter, parameters shall be guaranteed to the limit specified.
- Load step transition time between 2 and 10 microseconds.
- Recovery time is measured from initiation of the transient to where  $V_{\text{OUT}}$  has returned to within  $\pm 1\%$  of  $V_{\text{OUT}}$  at 50% load.
- Input step transient time between 1 and 10 microseconds.
- Turn-on delay time measurement is for either a step application of power at the input or the removal of a ground signal from the inhibit pin while power is applied to the input.

**Block Diagram**

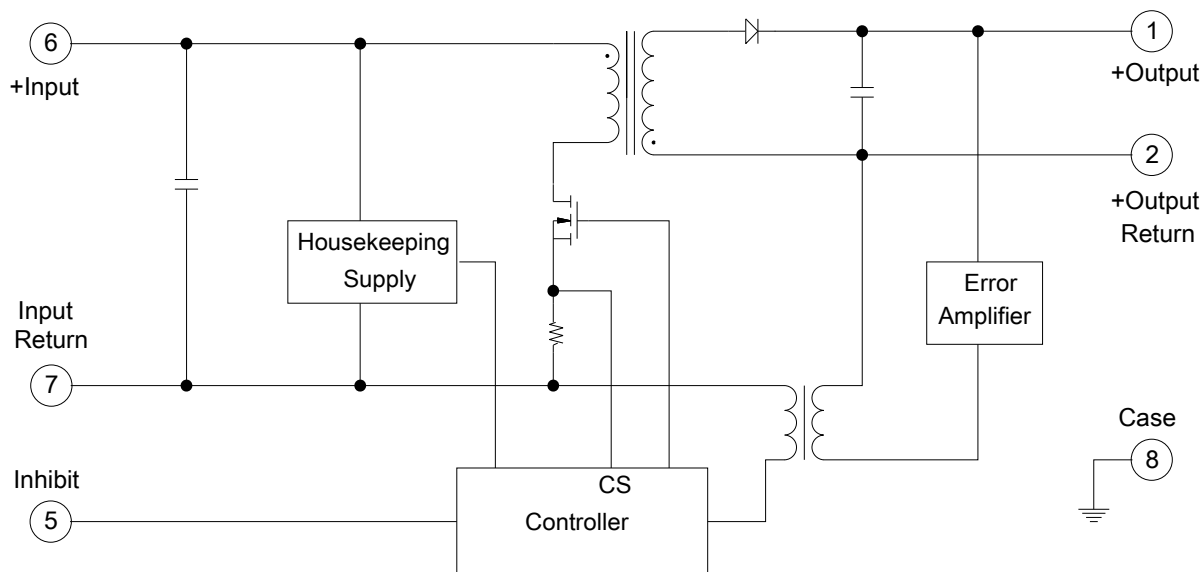

**Application Information**

**Inhibit Function**

Connecting the inhibit input (Pin 5) to input common (Pin 7) will cause the converter to shut down. It is recommended that the enable pin be driven by an open collector device capable of sinking at least 400  $\mu$ A of current. The open circuit voltage of the inhibit input is 10 +1.0 V<sub>DC</sub>.

**EMI Filter**

An optional EMI filter is available (AFH461) will reduce the input ripple current to levels below the limits imposed by MIL-STD-461 CE03.

**Radiation Specifications**

Parameter	Condition	Min	Typ	Max	Unit
Total Ionizing Dose	MIL-STD-883, Method 1019.4 Operating bias applied during exposure	25			kRads (Si)
Heavy Ion (Single event effects)	BNL Dual Van de Graf Generator	60			MeV·cm <sup>2</sup> /mg

IR HiRel currently does not have a DLA certified Radiation Hardness Assurance Program.

**Mechanical Outline**

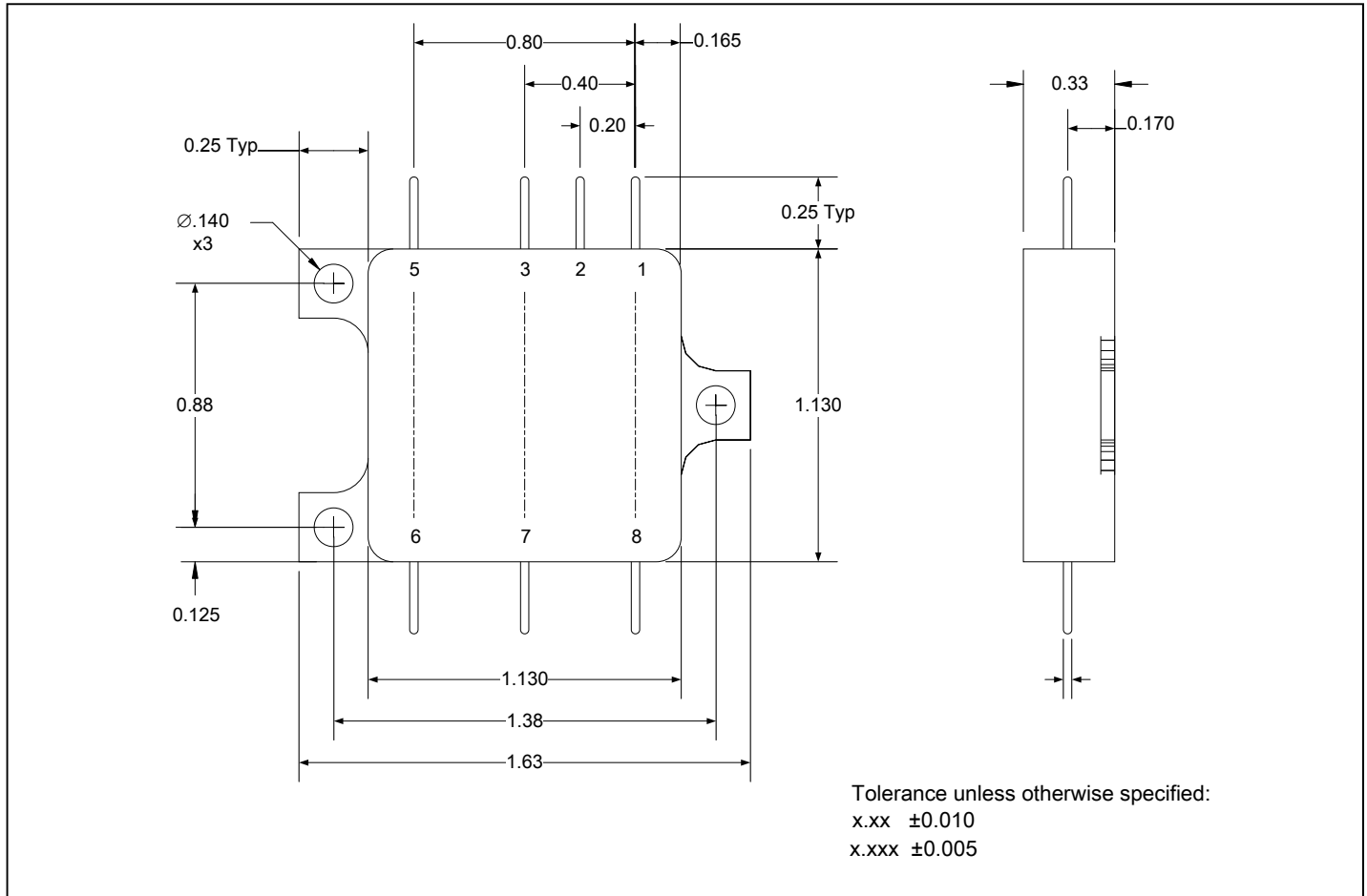

**Pin Designation**

Pin #	Designation
1	+ Output
2	Output Return
3	NC
4	Blank
5	Inhibit
6	+ Input
7	Input Return
8	Case Ground

**Standard Microcircuit Drawing Equivalence**

Standard Microcircuit Drawing Number	IR HiRel Standard Part Number
5962-04247	AMA2805S
5962-04248	AMA2812S
5962-04249	AMA2815S

**Device Screening**

Requirement	MIL-STD-883 Method	No Suffix ②	CH ②	EM ③
Temperature Range	—	-55°C to +125°C	-55°C to +125°C	-55°C to +85°C
Element Evaluation	MIL-PRF-38534	Class H	Class H	N/A
Non-Destructive Bond Pull	2023	N/A	N/A	N/A
Internal Visual	2017	Yes	Yes	①
Temperature Cycle	1010	Cond C	Cond C	Cond C
Constant Acceleration	2001, Y1 Axis	3000 Gs	3000 Gs	3000 Gs
PIND	2020	Cond A	Cond A	N/A
Burn-In	1015	320 hrs @ 125°C (2 x 160 hrs)	320 hrs @ 125°C (2 x 160 hrs)	48 hrs @ 125°C
Final Electrical (Group A)	MIL-PRF-38534 & Specification	-55°C, +25°C, +125°C	-55°C, +25°C, +85°C	-55°C, +25°C, +85°C
PDA	MIL-PRF-38534	2%	2%	N/A
Seal, Fine and Gross	1014	Cond A, C	Cond A, C	Cond A
Radiographic	2012	Yes	Yes	N/A
External Visual	2009	Yes	Yes	①

**Notes:**

- ① Best commercial practice.
- ② Devices with "/CH" suffix is a DLA class H compliant without radiation performance. No suffix is a radiation rated device but not available as a DLA qualified SMD per MIL-PRF-38534.
- ③ Any Engineering Model (EM) build with the "EM" Suffix shall only be form, fit and functional equivalent to its Flight Model (FM) counterpart, and it may not meet the radiation performance. The EM Model shall not be expected comply with MIL-PRF-38534 flight quality/workmanship standards, and configuration control. An EM build may use electrical equivalent commercial grade components. IR HiRel will provide a list of non-compliance items upon request.

**Part Numbering**

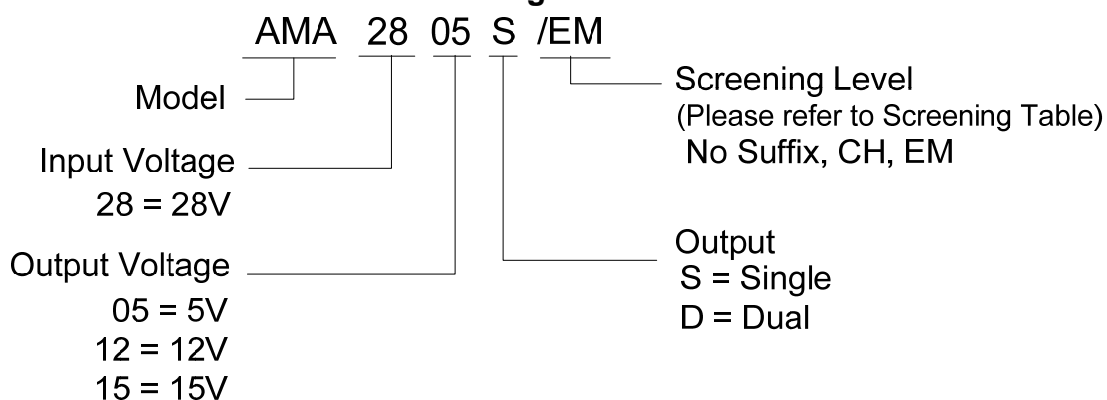

### **IMPORTANT NOTICE**

The information given in this document shall be in no event regarded as guarantee of conditions or characteristic. The data contained herein is a characterization of the component based on internal standards and is intended to demonstrate and provide guidance for typical part performance. It will require further evaluation, qualification and analysis to determine suitability in the application environment to confirm compliance to your system requirements.

With respect to any example hints or any typical values stated herein and/or any information regarding the application of the product, Infineon Technologies hereby disclaims any and all warranties and liabilities of any kind including without limitation warranties on non- infringement of intellectual property rights and any third party.

In addition, any information given in this document is subject to customer's compliance with its obligations stated in this document and any applicable legal requirements, norms and standards concerning customer's product and any use of the product of Infineon Technologies in customer's applications.

The data contained in this document is exclusively intended for technically trained staff. It is the responsibility of any customer's technical departments to evaluate the suitability of the product for the intended applications and the completeness of the product information given in this document with respect to applications.

For further information on the product, technology, delivery terms and conditions and prices, please contact your local sales representative or go to ([www.infineon.com/hirel](http://www.infineon.com/hirel)).

### **WARNING**

Due to technical requirements products may contain dangerous substances. For information on the types in question, please contact your nearest Infineon Technologies office.