



2N2219A 2N2222A

HIGH SPEED SWITCHES

PRELIMINARY DATA

DESCRIPTION

The 2N2219A and 2N2222A are silicon Planar Epitaxial NPN transistors in Jedec TO-39 (for 2N2219A) and in Jedec TO-18 (for 2N2222A) metal case. They are designed for high speed switching application at collector current up to 500mA, and feature useful current gain over a wide range of collector current, low leakage currents and low saturation voltage.

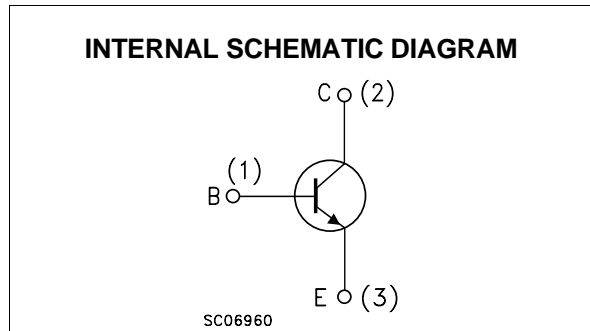
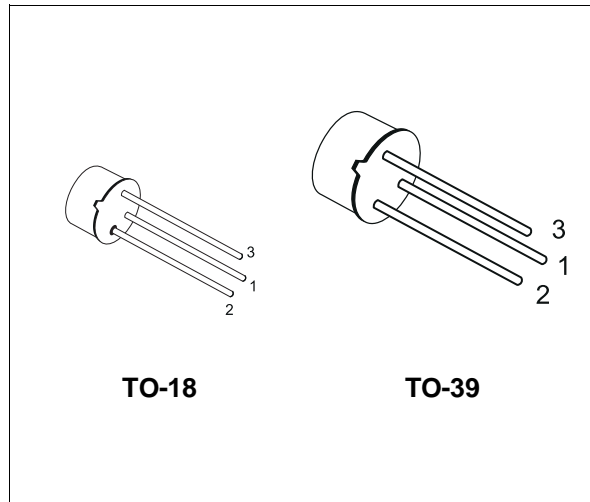

ABSOLUTE MAXIMUM RATINGS

Symbol	Parameter	Value	Unit
V_{CBO}	Collector-Base Voltage ($I_E = 0$)	75	V
V_{CEO}	Collector-Emitter Voltage ($I_B = 0$)	40	V
V_{EBO}	Emitter-Base Voltage ($I_C = 0$)	6	V
I_C	Collector Current	0.6	A
I_{CM}	Collector Peak Current ($t_p < 5$ ms)	0.8	A
P_{tot}	Total Dissipation at $T_{amb} \leq 25$ °C for 2N2219A for 2N2222A at $T_C \leq 25$ °C for 2N2219A for 2N2222A	0.8	W
		0.5	W
		3	W
		1.8	W
T_{stg}	Storage Temperature	-65 to 175	°C
T_j	Max. Operating Junction Temperature	175	°C

2N2219A / 2N2222A

THERMAL DATA

			TO-39	TO-18	
R _{thj-case}	Thermal Resistance Junction-Case	Max	50	83.3	°C/W
R _{thj-amb}	Thermal Resistance Junction-Ambient	Max	187.5	300	°C/W

ELECTRICAL CHARACTERISTICS (T_{case} = 25 °C unless otherwise specified)

Symbol	Parameter	Test Conditions	Min.	Typ.	Max.	Unit
I _{CBO}	Collector Cut-off Current (I _E = 0)	V _{CB} = 60 V V _{CB} = 60 V T _j = 150 °C			10 10	nA μA
I _{CEX}	Collector Cut-off Current (V _{BE} = -3V)	V _{CE} = 60 V			10	nA
I _{BEX}	Base Cut-off Current (V _{BE} = -3V)	V _{CE} = 60 V			20	nA
I _{EBO}	Emitter Cut-off Current (I _C = 0)	V _{EB} = 3 V			10	nA
V _{(BR)CBO}	Collector-Base Breakdown Voltage (I _E = 0)	I _C = 10 μA	75			V
V _{(BR)CEO*}	Collector-Emitter Breakdown Voltage (I _B = 0)	I _C = 10 mA	40			V
V _{(BR)EBO}	Emitter-Base Breakdown Voltage (I _C = 0)	I _E = 10 μA	6			V
V _{CE(sat)*}	Collector-Emitter Saturation Voltage	I _C = 150 mA I _B = 15 mA I _C = 500 mA I _B = 50 mA			0.3 1	V V
V _{BE(sat)*}	Base-Emitter Saturation Voltage	I _C = 150 mA I _B = 15 mA I _C = 500 mA I _B = 50 mA	0.6		1.2 2	V V
h _{FE*}	DC Current Gain	I _C = 0.1 mA V _{CE} = 10 V I _C = 1 mA V _{CE} = 10 V I _C = 10 mA V _{CE} = 10 V I _C = 150 mA V _{CE} = 10 V I _C = 500 mA V _{CE} = 10 V I _C = 150 mA V _{CE} = 1 V I _C = 10 mA V _{CE} = 10 V T _{amb} = -55 °C	35 50 75 100 40 50 35		300	
h _{fe*}	Small Signal Current Gain	I _C = 1 mA V _{CE} = 10 V f = 1KHz I _C = 10 mA V _{CE} = 10 V f = 1KHz	50 75		300 375	
f _T	Transition Frequency	I _C = 20 mA V _{CE} = 20 V f = 100 MHz		300		MHz
C _{EBO}	Emitter-Base Capacitance	I _C = 0 V _{EB} = 0.5 V f = 100KHz			25	pF
C _{CBO}	Collector-Base Capacitance	I _E = 0 V _{CB} = 10 V f = 100 KHz			8	pF
R _{e(hie)}	Real Part of Input Impedance	I _C = 20 mA V _{CE} = 20 V f = 300MHz			60	Ω

* Pulsed: Pulse duration = 300 μs, duty cycle ≤ 1 %

ELECTRICAL CHARACTERISTICS (continued)

Symbol	Parameter	Test Conditions	Min.	Typ.	Max.	Unit
NF	Noise Figure	$I_C = 0.1 \text{ mA}$ $V_{CE} = 10 \text{ V}$ $f = 1\text{KHz}$ $R_g = 1\text{K}\Omega$		4		dB
h_{ie}	Input Impedance	$I_C = 1 \text{ mA}$ $V_{CE} = 10 \text{ V}$ $I_C = 10 \text{ mA}$ $V_{CE} = 10 \text{ V}$	2 0.25		8 1.25	$\text{k}\Omega$ $\text{k}\Omega$
h_{re}	Reverse Voltage Ratio	$I_C = 1 \text{ mA}$ $V_{CE} = 10 \text{ V}$ $I_C = 10 \text{ mA}$ $V_{CE} = 10 \text{ V}$			8 4	10^{-4} 10^{-4}
h_{oe}	Output Admittance	$I_C = 1 \text{ mA}$ $V_{CE} = 10 \text{ V}$ $I_C = 10 \text{ mA}$ $V_{CE} = 10 \text{ V}$	5 25		35 200	μS μS
t_d^{**}	Delay Time	$V_{CC} = 30 \text{ V}$ $I_C = 150 \text{ mA}$ $I_{B1} = 15 \text{ mA}$ $V_{BB} = -0.5 \text{ V}$			10	ns
t_r^{**}	Rise Time	$V_{CC} = 30 \text{ V}$ $I_C = 150 \text{ mA}$ $I_{B1} = 15 \text{ mA}$ $V_{BB} = -0.5 \text{ V}$			25	ns
t_s^{**}	Storage Time	$V_{CC} = 30 \text{ V}$ $I_C = 150 \text{ mA}$ $I_{B1} = -I_{B2} = 15 \text{ mA}$			225	ns
t_f^{**}	Fall Time	$V_{CC} = 30 \text{ V}$ $I_C = 150 \text{ mA}$ $I_{B1} = -I_{B2} = 15 \text{ mA}$			60	ns
$r_{bb'}$, $C_{b'c}$	Feedback Time Constant	$I_C = 20 \text{ mA}$ $V_{CE} = 20 \text{ V}$ $f = 31.8\text{MHz}$			150	ps

* Pulsed: Pulse duration = 300 μs , duty cycle $\leq 1\%$

** See test circuit

2N2219A / 2N2222A

Test Circuit for t_d , t_r

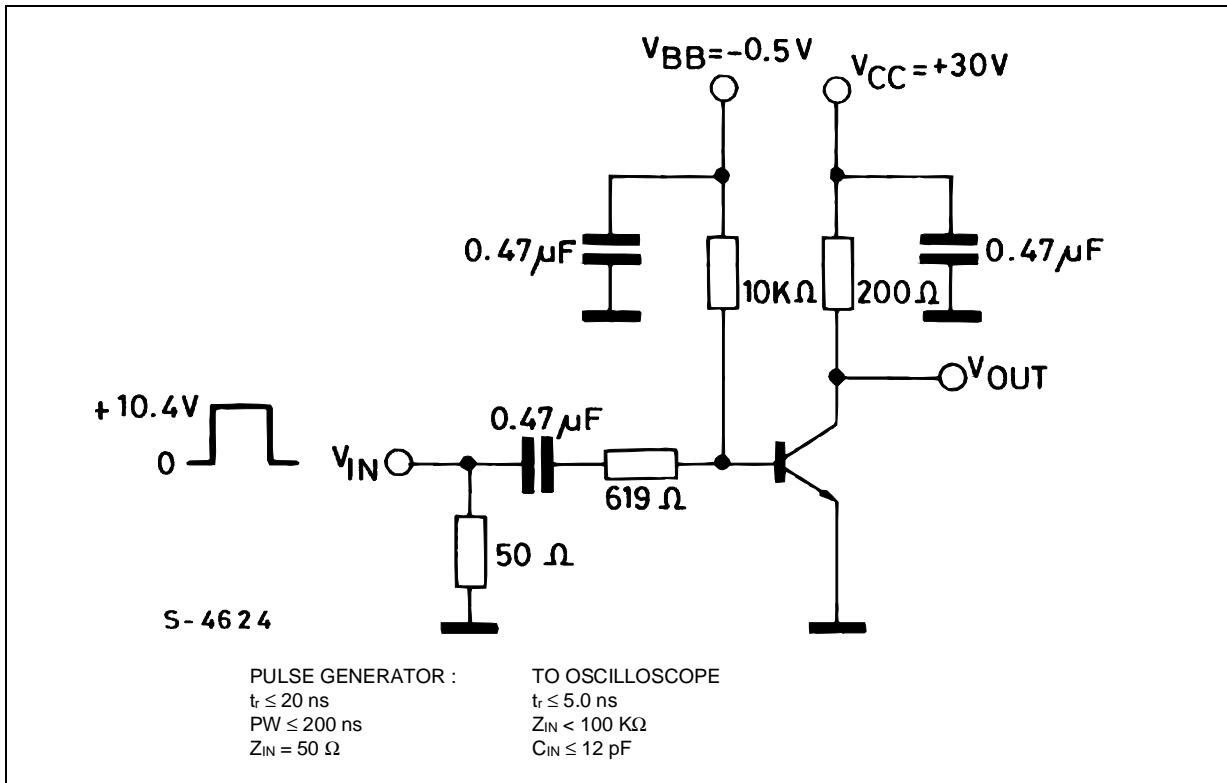

Test Circuit for t_d , t_r

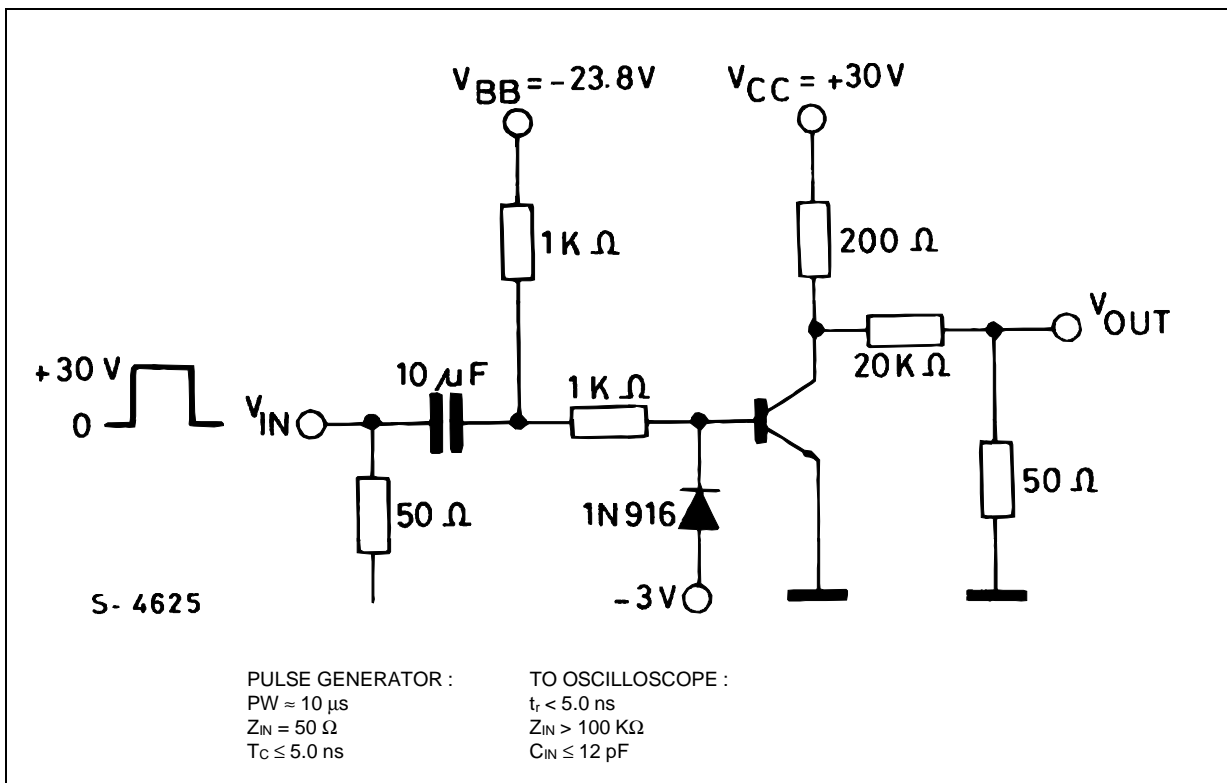

TO-18 MECHANICAL DATA

DIM.	mm			inch		
	MIN.	TYP.	MAX.	MIN.	TYP.	MAX.
A		12.7			0.500	
B			0.49			0.019
D			5.3			0.208
E			4.9			0.193
F			5.8			0.228
G	2.54			0.100		
H			1.2			0.047
I			1.16			0.045
L	45°			45°		

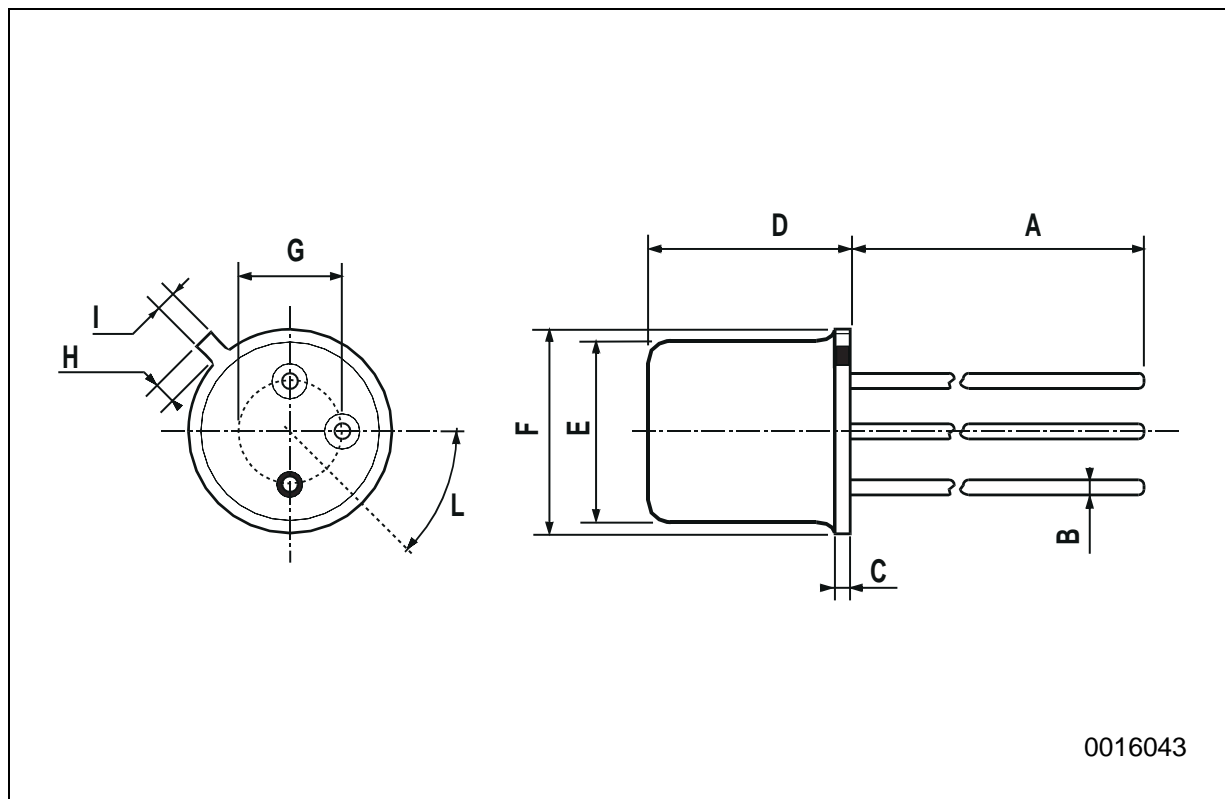

TO-39 MECHANICAL DATA

DIM.	mm			inch		
	MIN.	TYP.	MAX.	MIN.	TYP.	MAX.
A	12.7			0.500		
B			0.49			0.019
D			6.6			0.260
E			8.5			0.334
F			9.4			0.370
G	5.08			0.200		
H			1.2			0.047
I			0.9			0.035
L	45° (typ.)					

