

1V HIGH EFFICIENCY SYNCHRONOUS STEP UP CONVERTER

1 Features

- 0.6 TO 5.5V OPERATING INPUT VOLTAGE
- 1V START UP INPUT VOLTAGE
- INTERNAL SYNCHRONOUS RECTIFIER
- ZERO SHUT DOWN CURRENT
- 3.3V AND 5V FIXED OR ADJUSTABLE OUTPUT VOLTAGE (2V UP TO 5.2V)
- 120mΩ INTERNAL ACTIVE SWITCH
- LOW BATTERY VOLTAGE DETECTION
- REVERSE BATTERY PROTECTION

1.1 Applications

- ONE TO THREE CELL BATTERY DEVICES
- PDA AND HAND HELD INSTRUMENTS
- CELLULAR PHONES - DIGITAL CORDLESS PHONE
- PAGERS
- GPS
- DIGITAL CAMERAS

Figure 1. Package



Table 1. Order Codes

| Part Number | Package |
|-------------|-------------|
| L6920D | TSSOP8 Tube |
| L6920DTR | Tape & Reel |

2 Description

The L6920 is a high efficiency step-up controller requiring only three external components to realize the conversion from the battery voltage to the selected output voltage.

The start up is guaranteed at 1V and the device is operating down to 0.6V.

Internal synchronous rectifier is implemented with a 120mΩ P-channel MOSFET and, in order to improve the efficiency, a variable frequency control is implemented.

Figure 1. Application Circuit

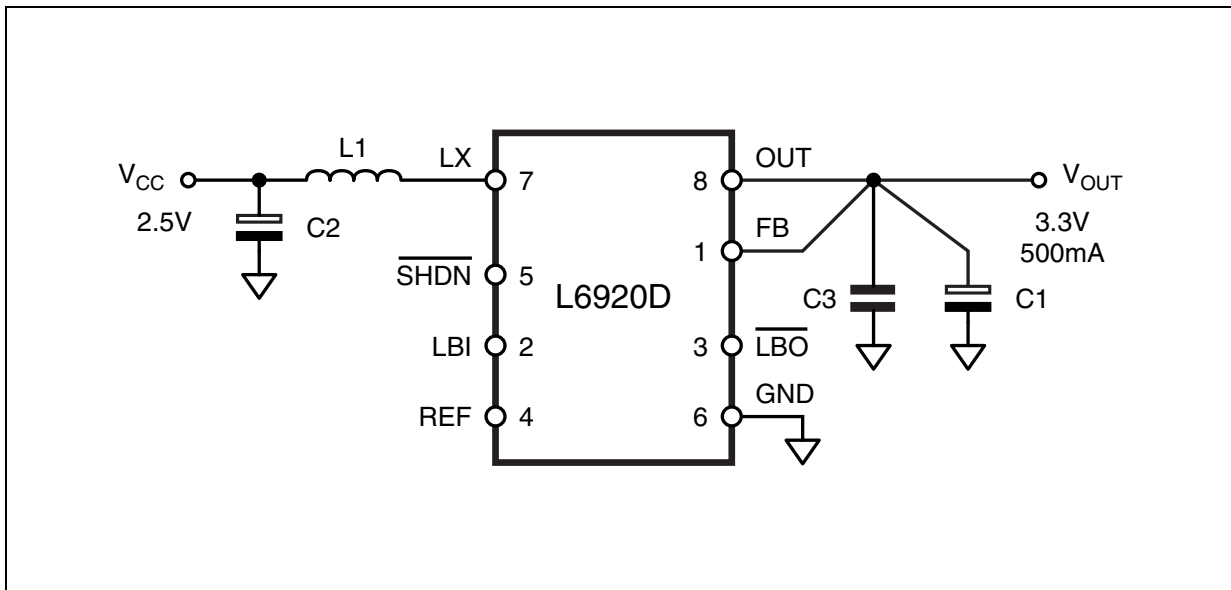

Table 1. Pin Description

| Pin | Name | Function |
|-----|-------------------|---|
| 1 | FB | Output voltage selector. Connect FB to GND for Vout=5V or to OUT for Vout=3.3V. Connect FB to an external resistor divider for adjustable output voltage (from 2V to 5.2V) [see R4 and R5, fig. 7]. |
| 2 | LBI | Battery low voltage detector input. The internal threshold is set to 1.23V. A resistor divider is needed to adjust the desired low battery threshold: $V_{LBI} = 1.23V \cdot \left(1 + \frac{R1}{R2}\right)$ [see R1 and R2, fig. 7] |
| 3 | \overline{LBO} | Battery low voltage detector output. If the voltage at the LBI pin drops below the internal threshold typ. 1.23V, \overline{LBO} goes low. The \overline{LBO} is an open drain output and so a pull-up resistor (about 200K Ω) has to be added for correct output setting [see R3, fig. 7]. |
| 4 | REF | 1.23V reference voltage. Bypass this output to GND with a 100nF capacitor for filtering high frequency noise. No capacitor is required for stability |
| 5 | \overline{SHDN} | Shutdown pin. When pin 5 is below 0.2V the device is in shutdown, when pin 5 is above 0.6V the device is operating. |
| 6 | GND | Ground pin |
| 7 | LX | Step-up inductor connection |
| 8 | OUT | Power OUTPUT pin |

Figure 2. Pin Connection (Top view)

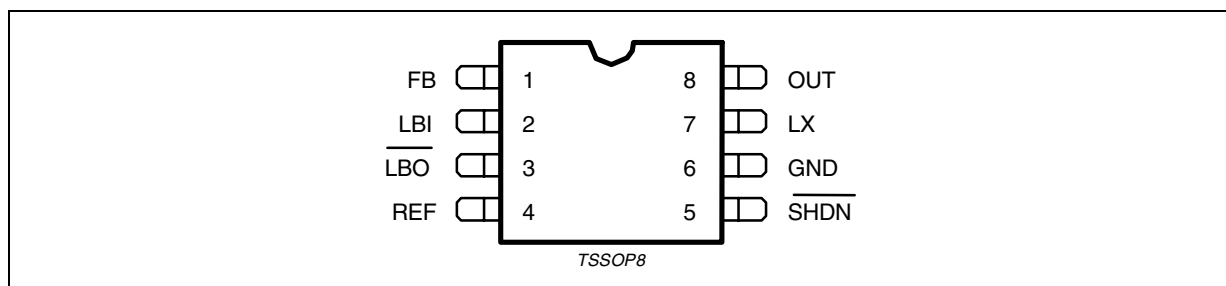

Table 2. Absolute Maximum Ratings

| Symbol | Parameter | Value | Unit |
|----------------------|------------------------|-------|------|
| V _{ccmax} | V _{cc} to GND | 6 | V |
| | LBI, SHDN, FB to GND | 6 | V |
| V _{out max} | Vout to GND | 6 | V |

Table 3. Thermal Data

| Symbol | Parameter | Value | Unit |
|-----------------------|--|-------|------|
| R _{th j-amb} | Thermal Resistance Junction to Ambient | 250 | °C/W |
| T _j | Maximum Junction Temperature | 150 | °C |

Table 4. Electrical Characteristics(V_{in} = 2V, FB = GND, T_{amb} = -40°C to 85°C and T_j < 125°C unless otherwise specified)

| Symbol | Parameter | Test Condition | Min. | Typ. | Max. | Unit |
|-------------------------------|-------------------------------------|---|-------|------|-------|------|
| V_{CC} SECTION | | | | | | |
| V _{in} | Minimum operating Input Voltage | | 0.6 | | | V |
| V _{in} | Minimum Start Up Input Voltage | | | | 1 | V |
| I _q | Quiescent Current | I _l = 0 mA, FB = 1.4V, V _{out} = 3.3V LBI = SHDN = 2V, T _j = T _{amb} | | 9 | 15 | μA |
| | | I _l = 0 mA, FB = 1.4V, V _{out} = 5V LBI = SHDN = 2V, T _j = T _{amb} | | 11 | 18 | μA |
| I _{sd} | Shut Down Current | V _{in} = 5V, I _l = 0 mA | | 0.1 | 1 | μA |
| I _{rev} | Reverse battery current | V _{in} = -4V, T _j = T _{amb} | | 0.1 | 2 | μA |
| POWER SECTION | | | | | | |
| R _{on-N} | Active switch ON resistance | | | 120 | 250 | mΩ |
| R _{on-P} | Synchronous switch ON resistance | | | 120 | 250 | mΩ |
| CONTROL SECTION | | | | | | |
| V _{out} | Output voltage | FB = OUT, I _l = 0 mA | 3.2 | 3.3 | 3.4 | V |
| | | FB = GND, I _l = 0 mA | 4.9 | 5 | 5.1 | V |
| | Output voltage range | External divider | 2 | | 5.2 | V |
| V _{LBI} | LBI threshold | | 1.18 | 1.23 | 1.27 | V |
| | | 0°C < T _j < 70°C | 1.205 | 1.23 | 1.255 | V |
| V _{LBO} | $\overline{\text{LBO}}$ logic LOW | I _l sink < 250μA | | 0.2 | 0.4 | V |
| I _{lim} | LX switch current limit | | 0.8 | 1 | 1.2 | A |
| T _{onmax} | Maximum on time | V _{out} = 2V to 5.3V | 3.75 | 5 | 6.25 | μs |
| T _{offmin} | Minimum off time | V _{out} = 2V to 5.3V | 0.75 | 1 | 1.25 | μs |
| $\overline{\text{SHDN}}$ | $\overline{\text{SHDN}}$ logic LOW | | | | 0.2 | V |
| | $\overline{\text{SHDN}}$ logic HIGH | | 0.6 | | | V |
| V _{ref} | Reference Voltage | | 1.18 | 1.23 | 1.27 | V |

Figure 3. Efficiency vs. Output Current

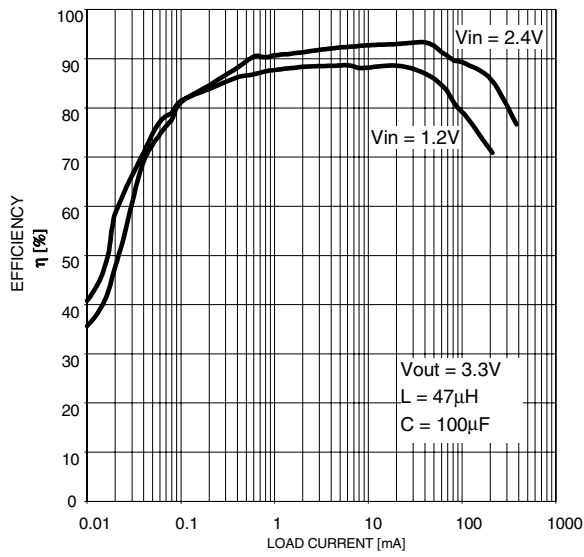

Figure 5. Startup Voltage vs Output Current

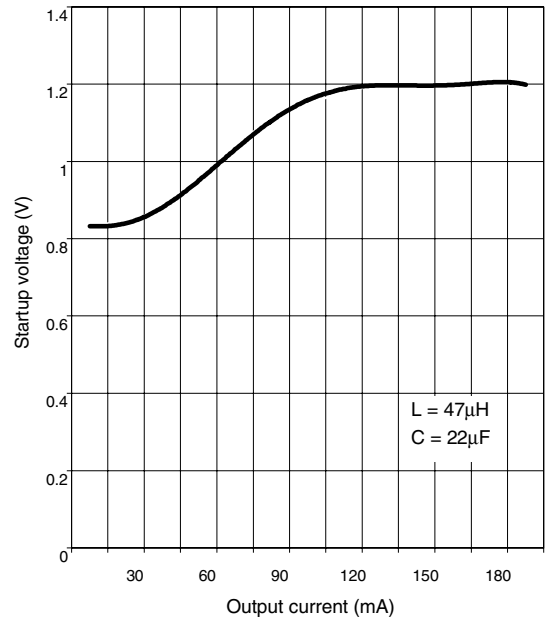

Figure 4. Efficiency vs. Output Current

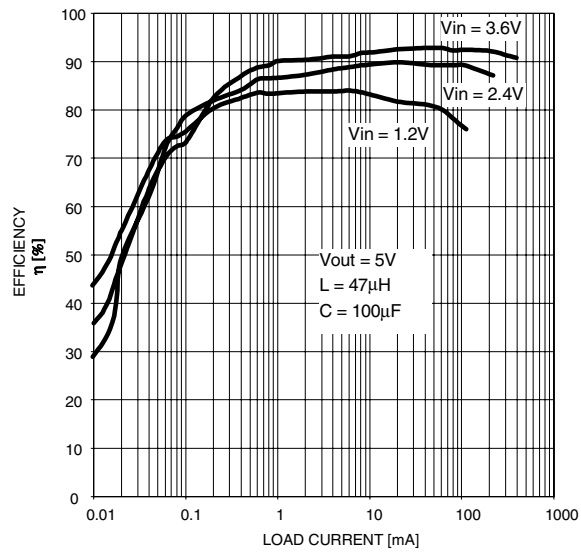

Figure 7. PFM mode Condition: $V_{out} = 5V$; $V_{in} = 1.5V$. Trace1: V_{out} (50mV~/div) Trace 4: I_L (100mA/div) Time div.: 5 μ s/div

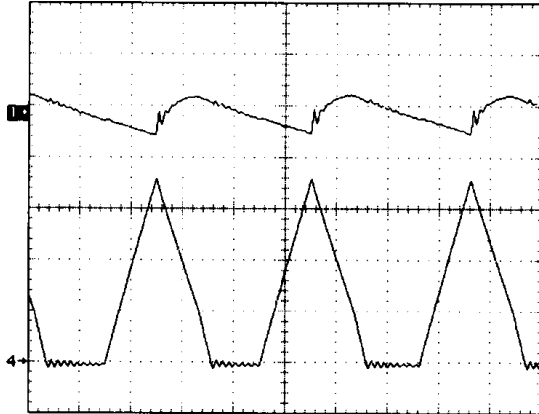

Figure 8. Heavier load - Train pulses overlapping. Trace1: V_{out} (100mV~/div) Trace 4: I_L (200mA/div) Time div.: 10 μ s/div

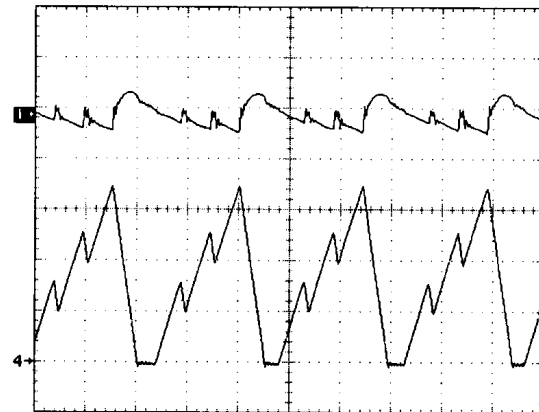

Figure 9. Heavy load - Inductor current ripples below I_{lim} Trace1: V_{out} (100mV~/div) Trace 4: I_L (200mA/div) Time div.: 20 μ s/div

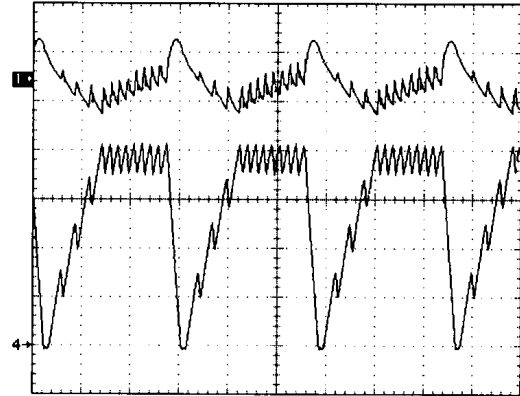
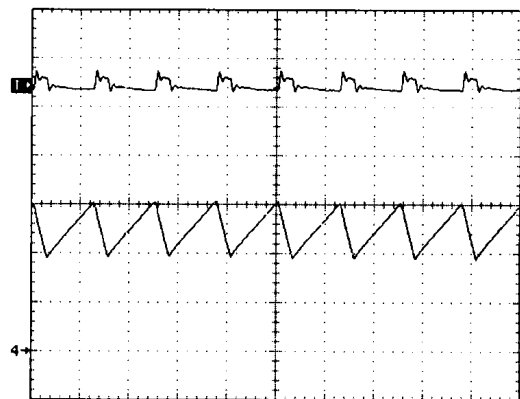

Figure 10. Heavy load and High ESR. Regulation falls in continuous mode of operation. Trace1: V_{out} (100mV~/div) Trace 4: I_L (200mA/div). Time div.: 5 μ s/div



When I_{load} is heavier, the pulse trains are overlapped. Figures 7 - 8 show some possible behaviors. Considering that current in the inductor is limited to 1A, the maximum load current is defined by the following relationship:

$$I_{load_lim} = \frac{V_{in}}{V_{out}} \cdot \left(I_{lim} - T_{off\ min} \cdot \frac{V_{out} - V_{in}}{2 \cdot L} \right) \cdot \eta \quad \text{eq. (1)}$$

Where η is the efficiency and $I_{lim} = 1A$.

Of course, if load is greater than I_{load_lim} the regulation is lost (figure 11).

Figure 11. No regulation. $I_{load} > I_{load_lim}$
Trace 1: V_{out} (100mV~/div) Trace 4: I_L (200mA/div).
Time div.: 5 μ s/div

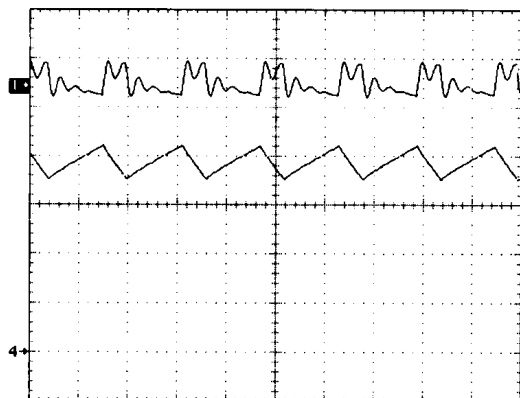

4.1 Start-up

One of the key features of L6920 is the startup at supply voltage down to 1V (please see the diagram in Figure 5. in case of heavy load).

The device leaves the startup mode of operation as soon as V_{OUT} goes over 1.4V. During startup, the synchronous switch is off and the energy is transferred to the load through its intrinsic body diode.

The N-channel switches with a very low R_{DSon} thanks to an internal charge pump used to bias the power mos gate. Because of this modified behavior, TON/TOFF times are lengthened. Current limit and zero crossing detection are still available.

4.2 Shutdown

In shutdown mode (\overline{SHDN} pulled low) all internal circuitries are turned off, minimizing the current provided by the battery ($I_{SHDN} < 100$ nA, in typical case). Both switches are turned off, and the low battery comparator output is forced in high impedance state.

The synchronous switch body diode causes a parasitic path between power supply and output that can't be avoided also in shutdown.

4.3 Low battery detection

The L6920 includes a low battery detector comparator. Threshold is V_{REF} voltage and a 1.3% hysteresis is added to avoid oscillations when input crosses the threshold slowly. The \overline{LBO} is an open drain output so a pull up resistor is required for a proper use.

4.4 Reverse polarity

A protection circuit has been implemented to avoid that L6920 and the battery are destroyed in case of wrong battery insertion.

In addition, this circuit has been designed so that the current required by the battery is zero also in reverse polarity.

5 Application Information

5.1 Output voltage selection

Output voltage must be selected acting on FB pin. Three choices are available: fixed 3.3V, 5V or adjustable output set via an external resistor divider.

Table 5. Output Voltage Selection

| | |
|-----------------------------|---|
| $V_{OUT} = 3.3V$ | FB pin connected to OUT (see application circuit) |
| $V_{OUT} = 5V$ | FB pin connected to GND |
| $2V \leq V_{OUT} \leq 5.2V$ | FB pin connected to a resistive divider $V_{OUT} = 1.23V \left(1 + \frac{R4}{R5} \right)$ |

Figure 12. Demoboard Circuit

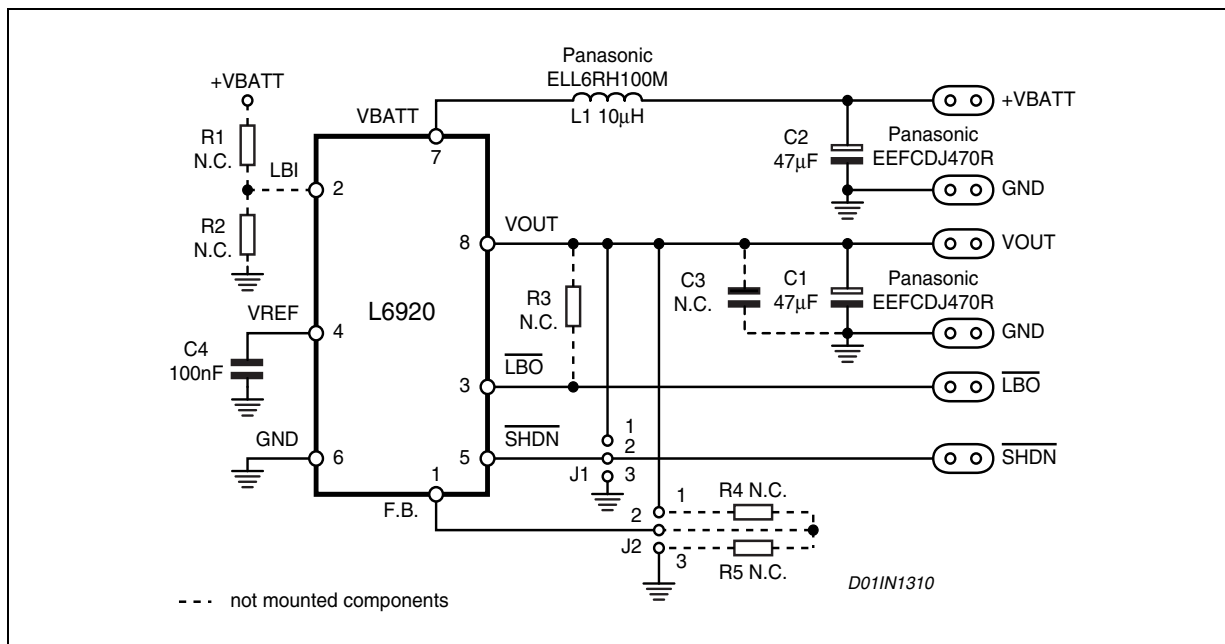

Table 6.

| Jumper | Position | Function |
|--------|----------|--|
| J1 | 1-2 | Device enabled |
| | 2-3 | Device disabled |
| J2 | None | Adjustable using R4 and R5 [not mounted] |
| | 1-2 | 3.3V output voltage |
| | 2-3 | 5V output voltage |

R4, R5 should be selected in the range of 100kΩ - 10MΩ to minimize consumption and error due to current sunk by FB pin (few nA).

5.2 Output capacitor selection

The output capacitor affects both efficiency and output ripple so its choice has to be considered with particular care.

The capacitance value should be in the range of about 10µF-100µF.

An additional, smaller, low ESR capacitor can be in parallel for high frequency filtering. A typical value can be around 1µF.

If very high performances, in terms of efficiency and output voltage ripple, are required, a very low ESR capacitor has to be chosen.

Ceramic capacitors are the lowest ESR but they are very expensive.

Other possibilities are low-ESR tantalum capacitors, available from KEMET, AVX and other sources. POSCAP capacitors from SANYO and polymeric capacitors from PANASONIC are also good.

Below there is a list of some capacitors suppliers. The cap values and rated voltages are only a suggested possibility

Table 7. Capacitors distributors main list

| Manufacturer | Series | Cap Value (μF) | Rated Voltage (V) | ESR ($\text{m}\Omega$) |
|--------------|--------------------|-----------------------------|-------------------|--------------------------|
| AVX | TPS | 15 to 470 | 6.3 | 50 to 1500 |
| KEMET | T510/T494/ T495 | 10 to 470 | 6 | 30 to 1000 |
| PANASONIC | EEFCD | 22 to 47 | 6.3 | 50 to 700 |
| SANYO POSCAP | TPA/B/C | 22 to 230 | 6.3 | 40 to 80 |
| SPRAGUE | 595D | 100 to 390 | 6.3 | 160 to 700 |

5.3 Inductor selection

Usually, inductors ranging between $5\mu\text{H}$ to $40\mu\text{H}$ satisfy most of the applications.

Small value inductors have smaller physical size and guarantee a faster response to load transient but in steady state condition a bigger ripple on output voltage is generated. In fact the output ripple voltage is given by I_{peak} multiplied by ESR. Furthermore, as shown in equation (1), inductor size affects also the maximum current deliverable to the load. Lastly, a low series resistance is suggested if very high efficiency values are needed. Anyway, the saturation current of the choke should be higher than the peak current limit of the device (1A).

Good surface mounting inductors are available from COILCRAFTS, COILTRONICS, MURATA and other sources. In the following table are listed some suggested components.

Table 8. Inductors distributors main list

| Manufacturer | Series | Inductor Value (μH) | Saturation Current (A) |
|--------------|----------|----------------------------------|------------------------|
| Coilcraft | DO1813HC | 22 to 33 | 1 to 1.2 |
| | DO1608 | 4.7 to 15 | 0.9 to 1.5 |
| Coiltronics | UP1B | 22 to 33 | 1 to 1.2 |
| | TP3 | 4.7 to 15 | 0.97 to 1.6 |
| BI | HM76-2 | 22 to 33 | 1 to 1.2 |
| | HM76-1 | 4.7 to 10 | 1 to 1.5 |
| Murata | LQN6C | 10 to 22 | 1.2 to 1.7 |
| Panasonic | ELL6SH | 10 to 22 | 0.9 to 1.5 |
| | ELL6RH | 5.1 to 10 | 11 to 1.55 |
| Sumida | CR43 | 4.7 to 10 | 0.84 to 1.15 |

5.4 Layout Guidelines

The board layout is very important in order to minimize noise, high frequency resonance problems and electromagnetic interference.

It is essential to keep as small as possible the high switching current circulating paths to reduce radiation and resonance problems. So, the output and input cap should be very close to the device.

The external resistor dividers, if used, should be as close as possible to the pins of the device (FB and LBI) and as far as possible from the high current circulating paths, to avoid pick up noise.

Large traces for high current paths and an extended groundplane, help to reduce the noise and increase the efficiency.

For an example of recommended layout see the following evaluation board.

Figure 13. Demoboard Components (Top side).

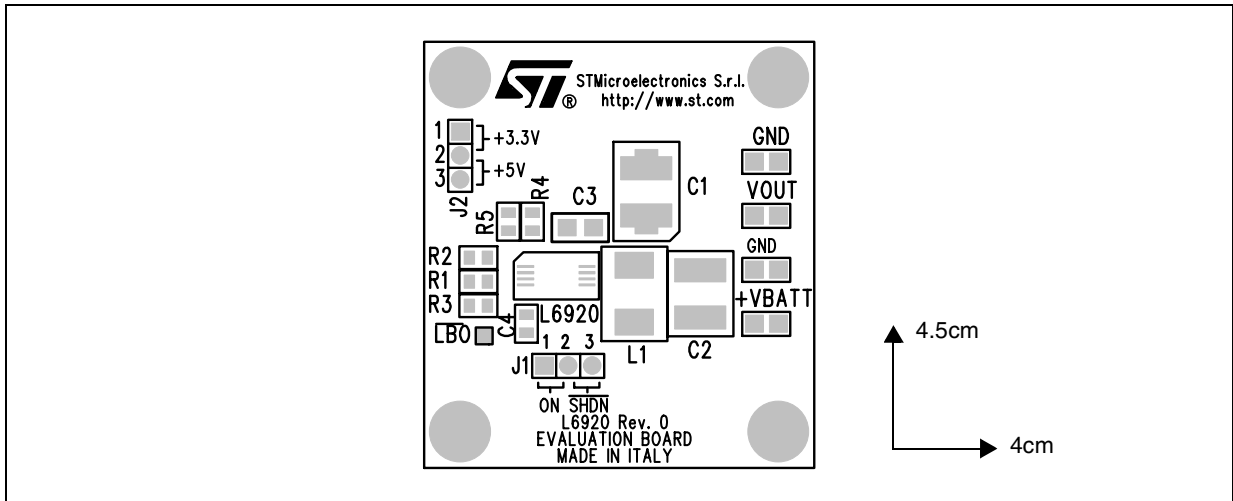

Figure 14. Demoboard Layout (Top side).

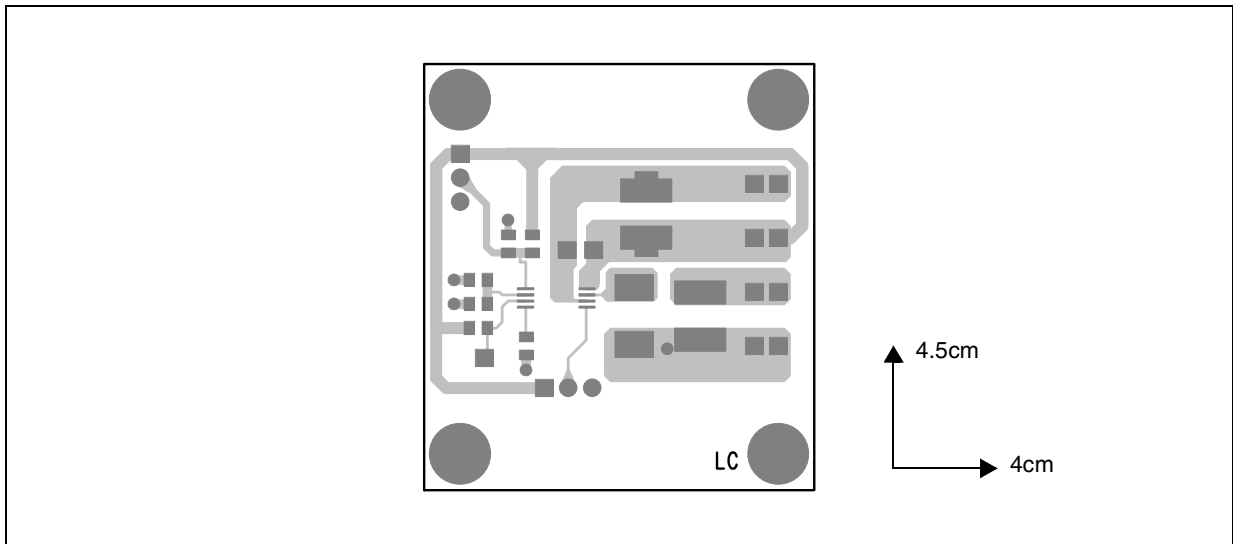
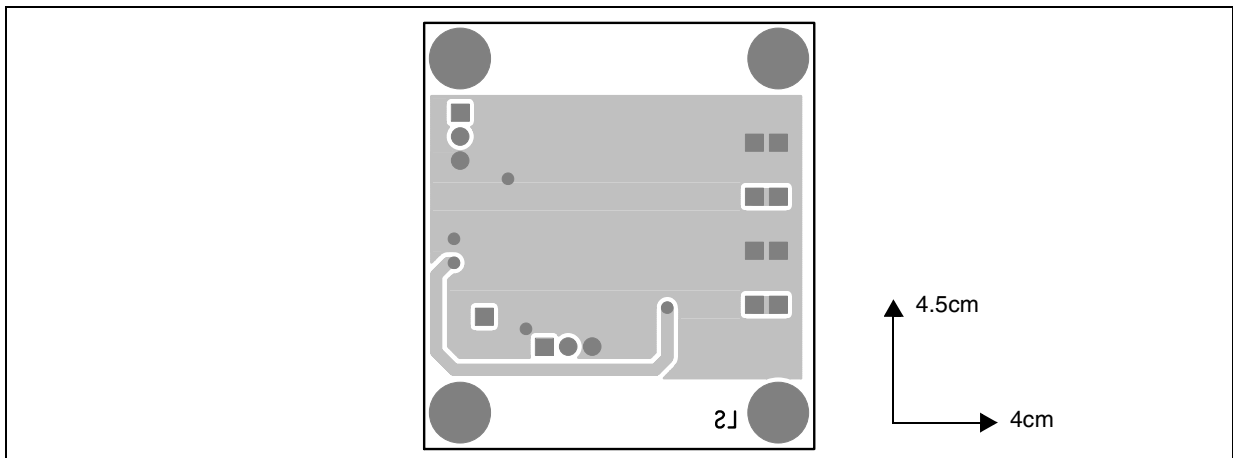
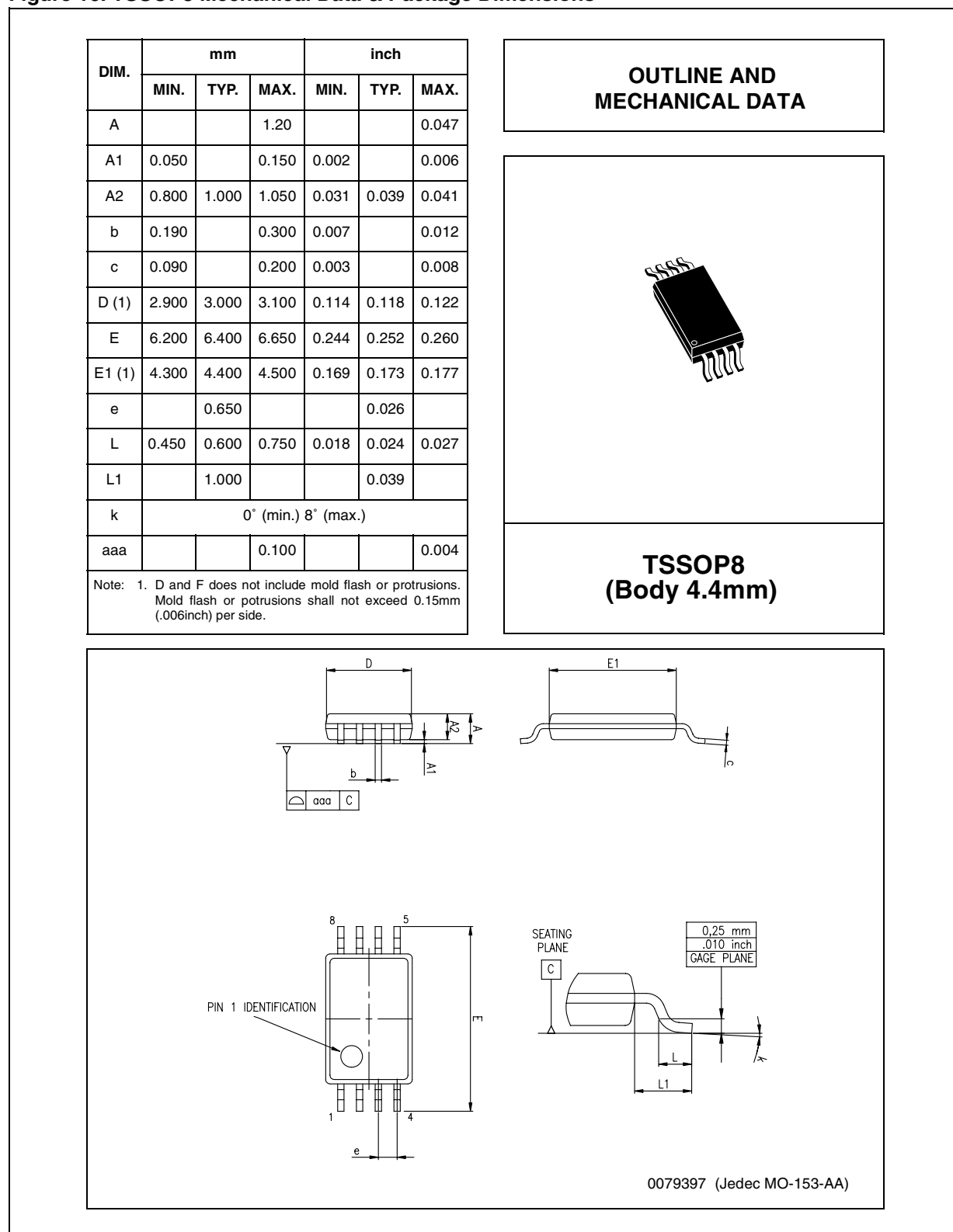

Figure 15. Demoboard Layout (Bottom side).



6 Package Information

Figure 16. TSSOP8 Mechanical Data & Package Dimensions



7 Revision History

Table 9. Revision History

| Date | Revision | Description of Changes |
|---------------|-----------------|--|
| May 2003 | 1 | First Issue. |
| February 2005 | 2 | Modified the max. value of the I_{SD} parameter in the Table 4 pag. 3. |

Information furnished is believed to be accurate and reliable. However, STMicroelectronics assumes no responsibility for the consequences of use of such information nor for any infringement of patents or other rights of third parties which may result from its use. No license is granted by implication or otherwise under any patent or patent rights of STMicroelectronics. Specifications mentioned in this publication are subject to change without notice. This publication supersedes and replaces all information previously supplied. STMicroelectronics products are not authorized for use as critical components in life support devices or systems without express written approval of STMicroelectronics.

The ST logo is a registered trademark of STMicroelectronics.
All other names are the property of their respective owners

© 2005 STMicroelectronics - All rights reserved

STMicroelectronics group of companies

Australia - Belgium - Brazil - Canada - China - Czech Republic - Finland - France - Germany - Hong Kong - India - Israel - Italy - Japan - Malaysia - Malta - Morocco - Singapore - Spain - Sweden - Switzerland - United Kingdom - United States of America

www.st.com

