

FQP11N40C, FQPF11N40C

QFET[®] MOSFET, N-Channel

400 V, 10.5 A, 530 mΩ

Description

This N-Channel enhancement mode power MOSFET is produced using ON Semiconductor proprietary planar stripe and DMOS technology. This advanced MOSFET technology has been especially tailored to reduce on-state resistance, and to provide superior switching performance and high avalanche energy strength. These devices are suitable for switched mode power supplies, active power factor correction (PFC), and electronic lamp ballasts.

Features

- 10.5 A, 400 V, $R_{DS(on)} = 530 \text{ m}\Omega$ (Max.) @ $V_{GS} = 10 \text{ V}$, $I_D = 5.25 \text{ A}$
- Low Gate Charge (Typ. 28 nC)
- Low Crss (Typ. 85 pF)
- 100% Avalanche Tested
- These Devices are Pb-Free and are RoHS Compliant



ON Semiconductor[®]

www.onsemi.com

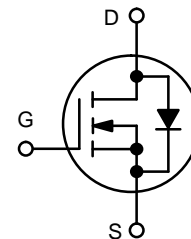
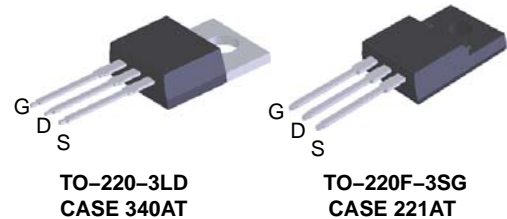

ORDERING INFORMATION

See detailed ordering, marking and shipping information on page 2 of this data sheet.

FQP11N40C, FQPF11N40C

ORDERING INFORMATION

| Device | Device Marking | Package | Shipping |
|------------|----------------|---|--------------------|
| FQP11N40C | FQP11N40C | TO-220 (Pb-Free) | 1,000 Units / Tube |
| FQPF11N40C | FQPF11N40C | TO-220 Fullpack, TO-220F-3SG (Pb-Free) | 1,000 Units / Tube |

MOSFET MAXIMUM RATINGS (T_C = 25°C unless otherwise noted)

| Symbol | Parameter | FQP11N40C | FQPF11N40C | Unit |
|-----------------------------------|--|------------|------------|------|
| V _{DSS} | Drain to Source Voltage | 400 | | V |
| I _D | Drain Current –Continuous (T _C = 25°C) –Continuous (T _C = 100°C) | 10.5 | 10.5 * | A |
| | | 6.6 | 6.6 * | A |
| I _{DM} | Drain Current – Pulsed (Note 1) | 42 | 42 * | A |
| V _{GSS} | Gate to Source Voltage | ± 30 | | V |
| E _{AS} | Single Pulsed Avalanche Energy (Note 2) | 360 | | mJ |
| I _{AR} | Avalanche Current (Note 1) | 11 | | A |
| E _{AR} | Repetitive Avalanche Energy (Note 1) | 13.5 | | mJ |
| dv/dt | Peak Diode Recovery dv/dt (Note 3) | 4.5 | | V/ns |
| P _D | Power Dissipation (T _C = 25°C) – Derate above 25°C | 135 | 44 | W |
| | | 1.07 | 0.35 | W/°C |
| T _J , T _{STG} | Operating and Storage Temperature Range | –55 to 150 | | °C |
| T _L | Maximum Lead Temperature for Soldering Purpose, 1/8" from Case for 5 Seconds | 300 | | °C |

Stresses exceeding those listed in the Maximum Ratings table may damage the device. If any of these limits are exceeded, device functionality should not be assumed, damage may occur and reliability may be affected.

*Drain current limited by maximum junction temperature

1. Repetitive Rating : Pulse width limited by maximum junction temperature.
2. L = 5.7 mH, I_{AS} = 10.5 A, V_{DD} = 50 V, R_G = 25 Ω, starting T_J = 25°C.
3. I_{SD} ≤ 10.5 A, di/dt ≤ 200 A/μs, V_{DD} ≤ BV_{DSS}, starting T_J = 25°C.

THERMAL CHARACTERISTICS

| Symbol | Parameter | FQP11N40C | FQPF11N40C | Unit |
|------------------|--|-----------|------------|------|
| R _{θJC} | Thermal Resistance, Junction to Case, Max | 0.93 | 2.86 | °C/W |
| R _{θJA} | Thermal Resistance, Junction to Ambient, Max | 62.5 | 62.5 | °C/W |

FQP11N40C, FQPF11N40C

ELECTRICAL CHARACTERISTICS (T_C = 25°C unless otherwise noted)

| Symbol | Parameter | Test Conditions | Min | Typ | Max | Unit |
|--------|-----------|-----------------|-----|-----|-----|------|
|--------|-----------|-----------------|-----|-----|-----|------|

Off Characteristics

| | | | | | | |
|--------------------------------------|---|---|-----|------|------|------|
| BV _{DSS} | Drain–Source Breakdown Voltage | V _{GS} = 0 V, I _D = 250 μA | 400 | | | V |
| $\frac{\Delta BV_{DSS}}{\Delta T_J}$ | Breakdown Voltage Temperature Coefficient | I _D = 250 μA, Referenced to 25°C | | 0.54 | | V/°C |
| I _{DSS} | Zero Gate Voltage Drain Current | V _{DS} = 400 V, V _{GS} = 0 V | | | 1 | μA |
| | | V _{DS} = 320 V, T _C = 125°C | | | 10 | μA |
| I _{GSSF} | Gate–Body Leakage Current, Forward | V _{GS} = 30 V, V _{DS} = 0 V | | | 100 | nA |
| I _{GSSR} | Gate–Body Leakage Current, Reverse | V _{GS} = –30 V, V _{DS} = 0 V | | | –100 | nA |

On Characteristics

| | | | | | | |
|---------------------|-----------------------------------|---|-----|------|------|---|
| V _{GS(th)} | Gate Threshold Voltage | V _{DS} = V _{GS} , I _D = 250 μA | 2.0 | | 4.0 | V |
| r _{DS(on)} | Static Drain–Source On–Resistance | V _{GS} = 10 V, I _D = 5.25 A | | 0.43 | 0.53 | Ω |
| g _{FS} | Forward Transconductance | V _{DS} = 40 V, I _D = 5.25 A | | 7.1 | | s |

Dynamic Characteristics

| | | | | | | |
|------------------|------------------------------|--|--|-----|------|----|
| C _{iss} | Input Capacitance | V _{DS} = 25 V, V _{GS} = 0 V, f = 1 MHz | | 840 | 1090 | pF |
| C _{oss} | Output Capacitance | | | 250 | 325 | pF |
| C _{rss} | Reverse Transfer Capacitance | | | 85 | 110 | pF |

Switching Characteristics

| | | | | | | |
|---------------------|---------------------|--|--|----|-----|----|
| t _{d(on)} | Turn–On Delay Time | V _{DD} = 200 V, I _D = 10.5 A, R _G = 25 Ω (Note 4) | | 14 | 40 | ns |
| t _r | Turn–On Rise Time | | | 89 | 190 | ns |
| t _{d(off)} | Turn–Off Delay Time | | | 81 | 170 | ns |
| t _f | Turn–Off Fall Time | | | 81 | 170 | ns |
| Q _g | Total Gate Charge | V _{DS} = 320 V, I _D = 10.5 A, R _G = 25 Ω (Note 4) | | 28 | 35 | nC |
| Q _{gs} | Gate–Source Charge | | | 4 | | nC |
| Q _{gd} | Gate–Drain Charge | | | 15 | | nC |

Drain–Source Diode Characteristics and Maximum Ratings

| | | | | | | |
|-----------------|---|--|--|-----|------|----|
| I _S | Maximum Continuous Drain–Source Diode Forward Current | | | | 10.5 | A |
| I _{SM} | Maximum Pulsed Drain–Source Diode Forward Current | | | | 42 | A |
| V _{SD} | Drain–Source Diode Forward Voltage | V _{GS} = 0 V, I _S = 10.5 A | | | 1.4 | V |
| t _{rr} | Reverse Recovery Time | V _{GS} = 0 V, I _S = 10.5 A, dI _F /dt = 100 A/μs | | 290 | | ns |
| Q _{rr} | Reverse Recovery Charge | | | 2.4 | | μC |

Product parametric performance is indicated in the Electrical Characteristics for the listed test conditions, unless otherwise noted. Product performance may not be indicated by the Electrical Characteristics if operated under different conditions.

4. Essentially independent of operating temperature.

TYPICAL PERFORMANCE CHARACTERISTICS

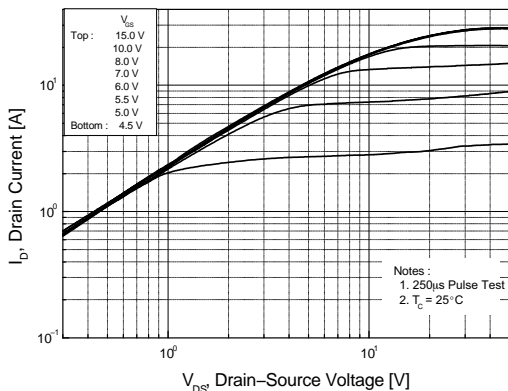

Figure 1. On-Region Characteristics

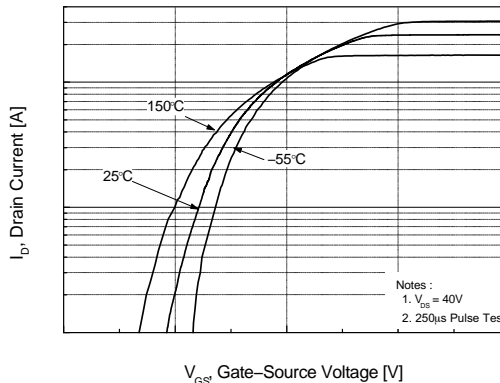

Figure 2. Transfer Characteristics

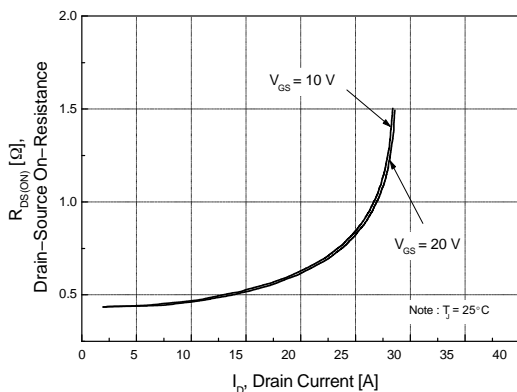

Figure 3. On-Resistance Variation vs Drain Current and Gate Voltage

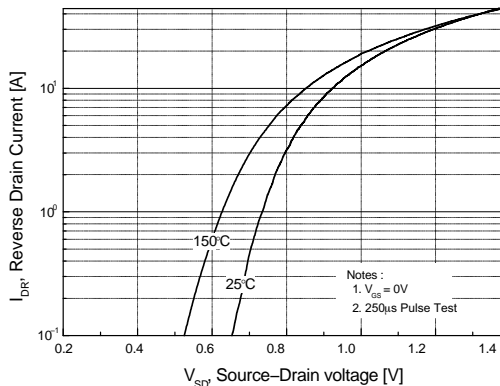

Figure 4. Body Diode Forward Voltage Variation vs. Source Current and Temperature

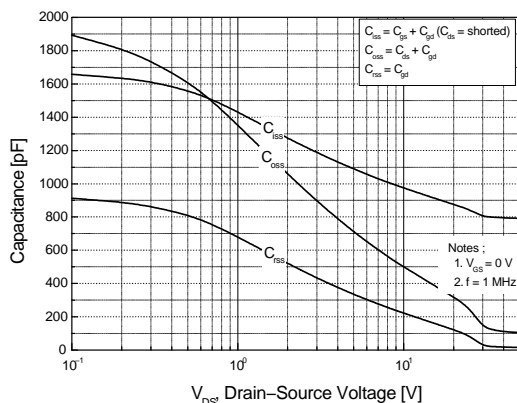

Figure 5. Capacitance Characteristics

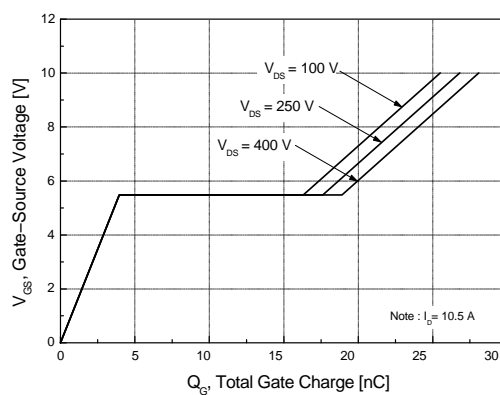

Figure 6. Gate Charge Characteristics

FQP11N40C, FQPF11N40C

TYPICAL PERFORMANCE CHARACTERISTICS

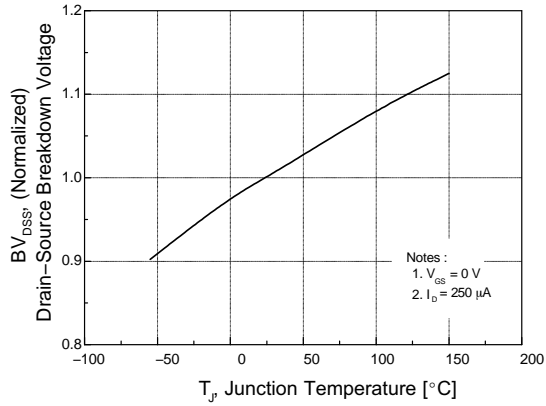

Figure 7. Breakdown Voltage Variation vs. Temperature

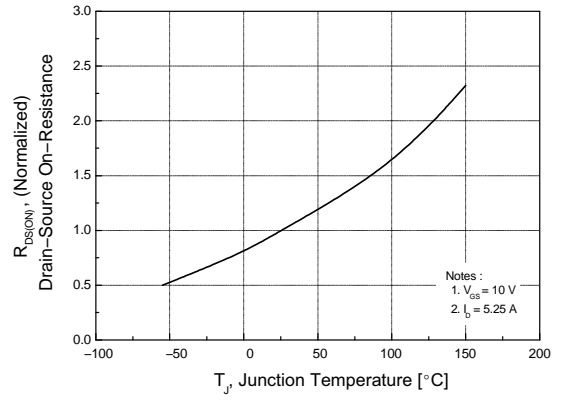

Figure 8. On-Resistance Variation vs. Temperature

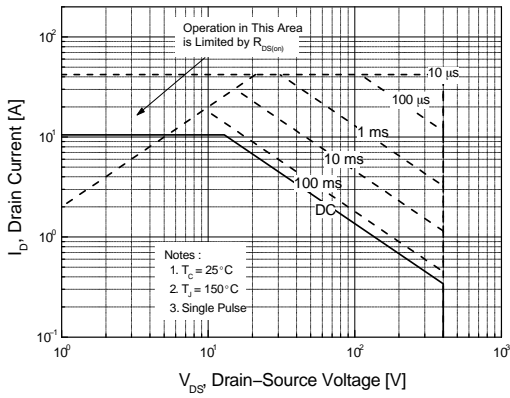

Figure 9. Maximum Safe Operating Area of FQP11N40C

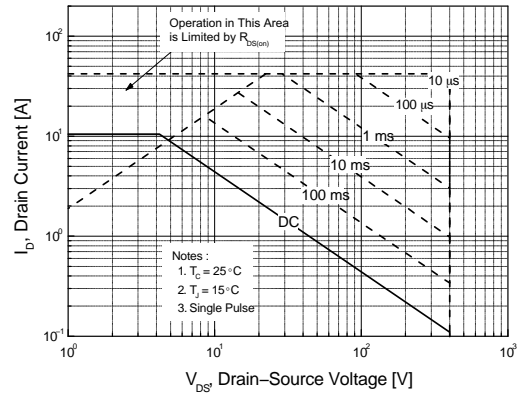

Figure 10. Maximum Safe Operating Area of FQPF11N40C

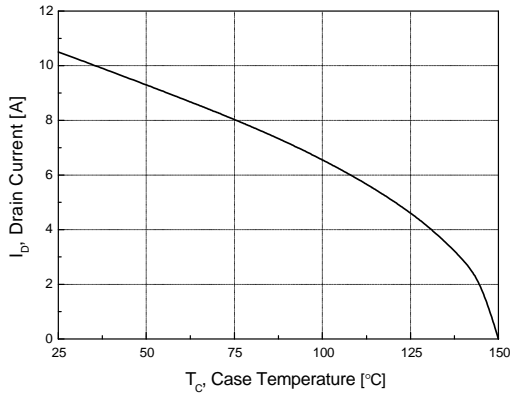

Figure 11. Maximum Drain Current

FQP11N40C, FQPF11N40C

TYPICAL PERFORMANCE CHARACTERISTICS

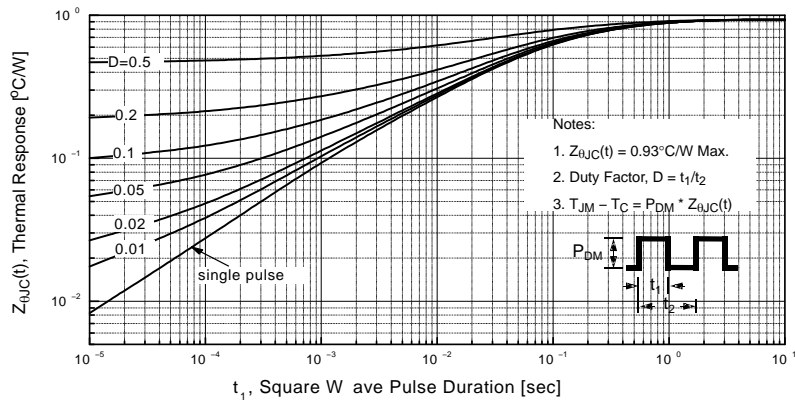

Figure 12. Transient Thermal Response Curve of FQP11N40C

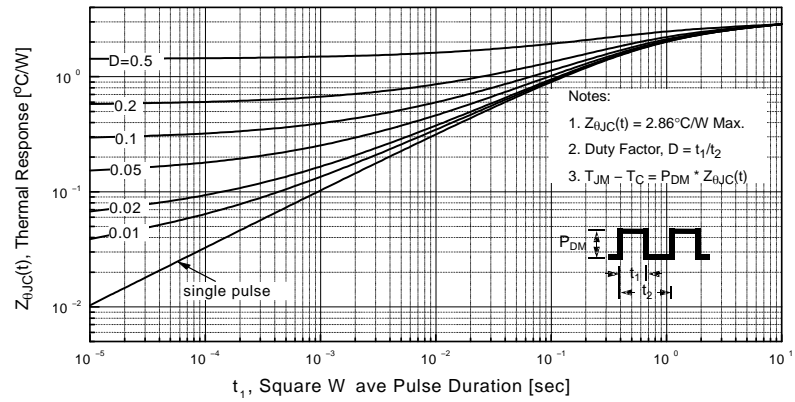

Figure 13. Transient Thermal Response Curve of FQPF11N40C

FQP11N40C, FQPF11N40C

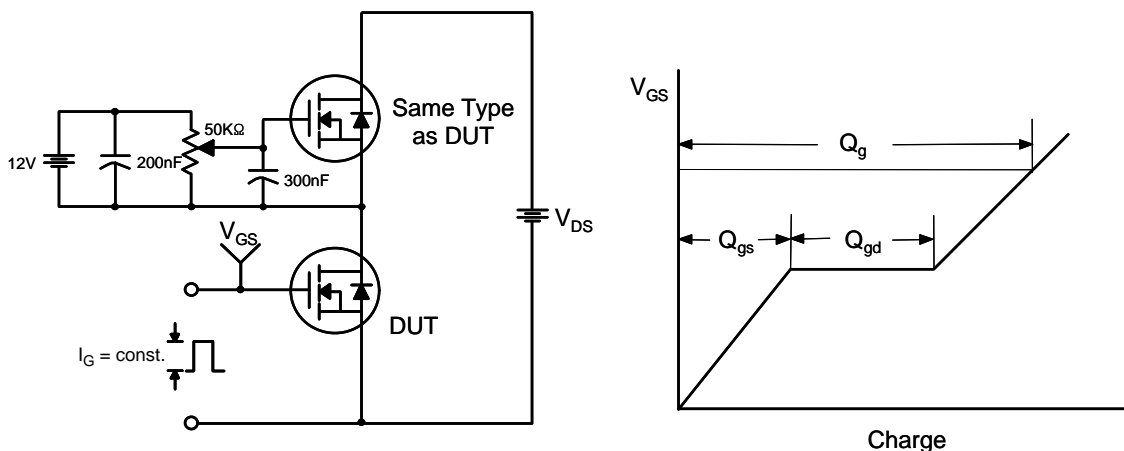

Figure 14. Gate Charge Test Circuit & Waveform

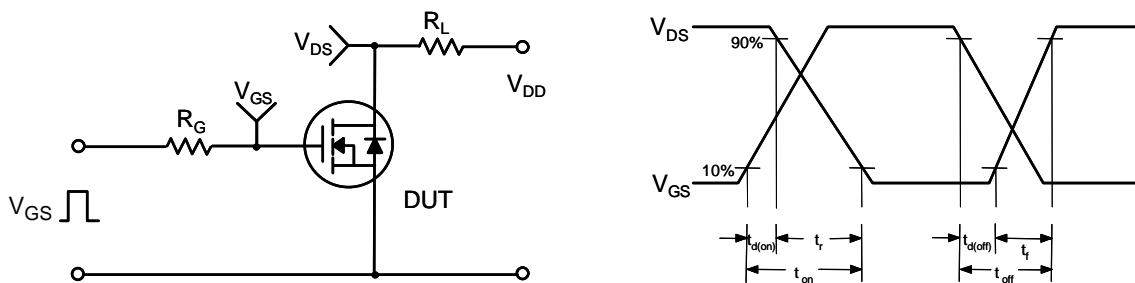

Figure 15. Resistive Switching Test Circuit & Waveforms

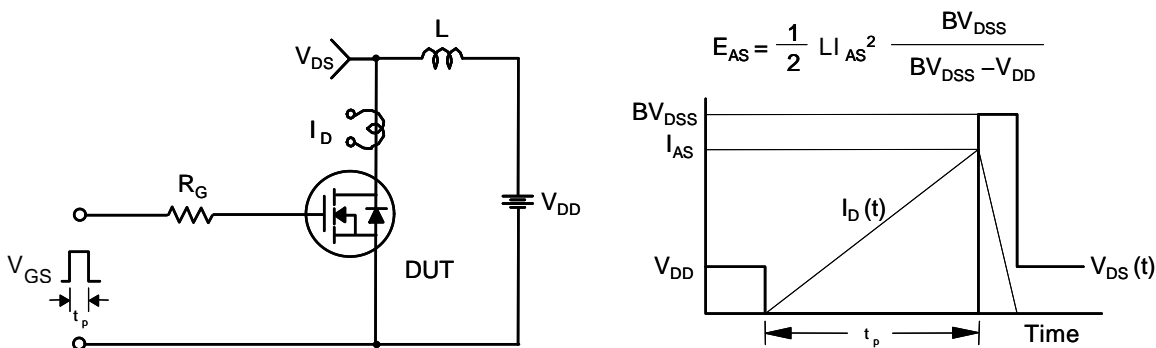

Figure 16. Unclamped Inductive Switching Test Circuit & Waveforms

FQP11N40C, FQPF11N40C

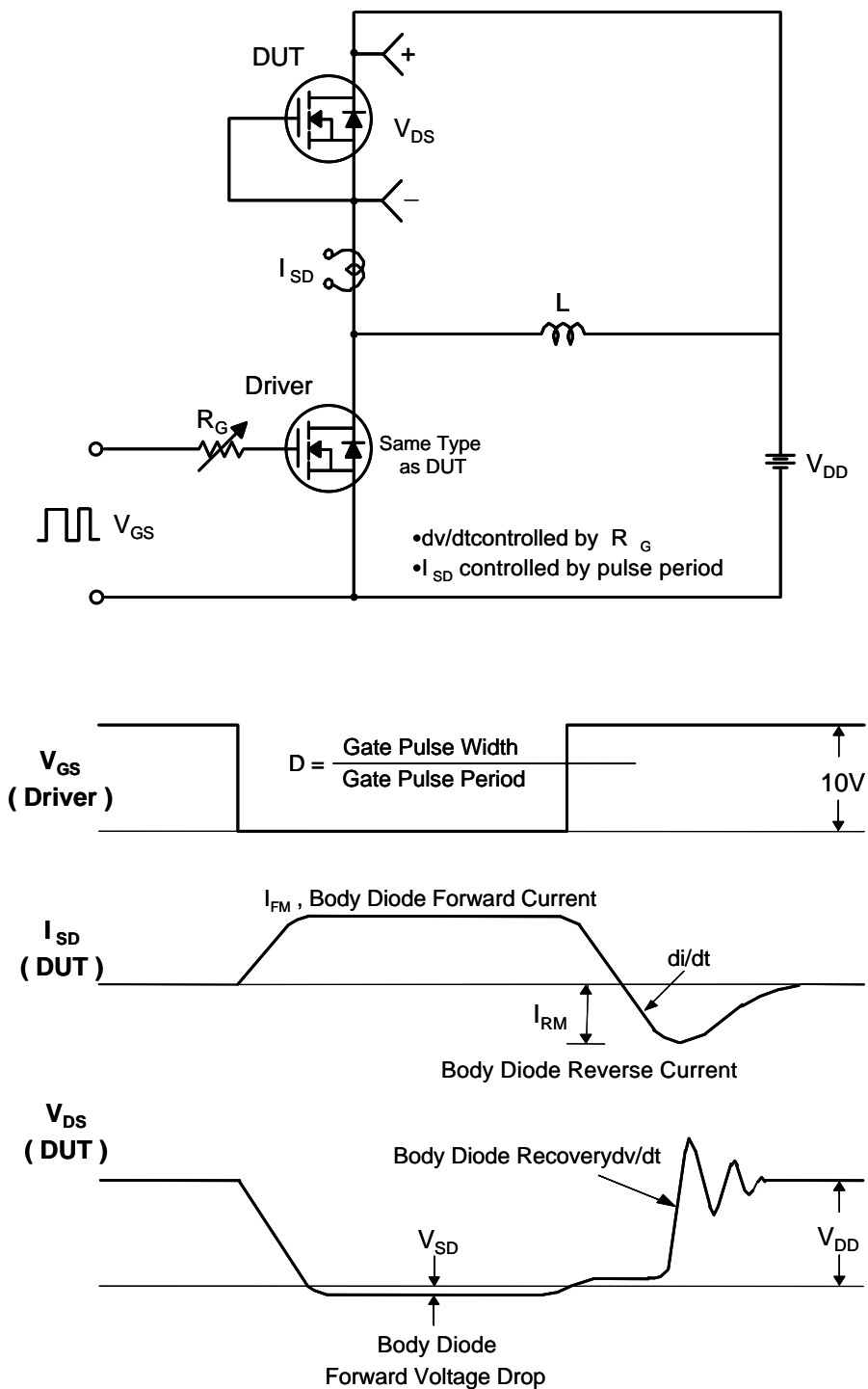

Figure 17. Peak Diode Recovery dv/dt Test Circuit & Waveforms

All other brand names and product names appearing in this document are registered trademarks or trademarks of their respective holders.

MECHANICAL CASE OUTLINE
PACKAGE DIMENSIONS

ON Semiconductor®



TO-220 Fullpack, 3-Lead / TO-220F-3SG
CASE 221AT
ISSUE A

DATE 12 NOV 2013

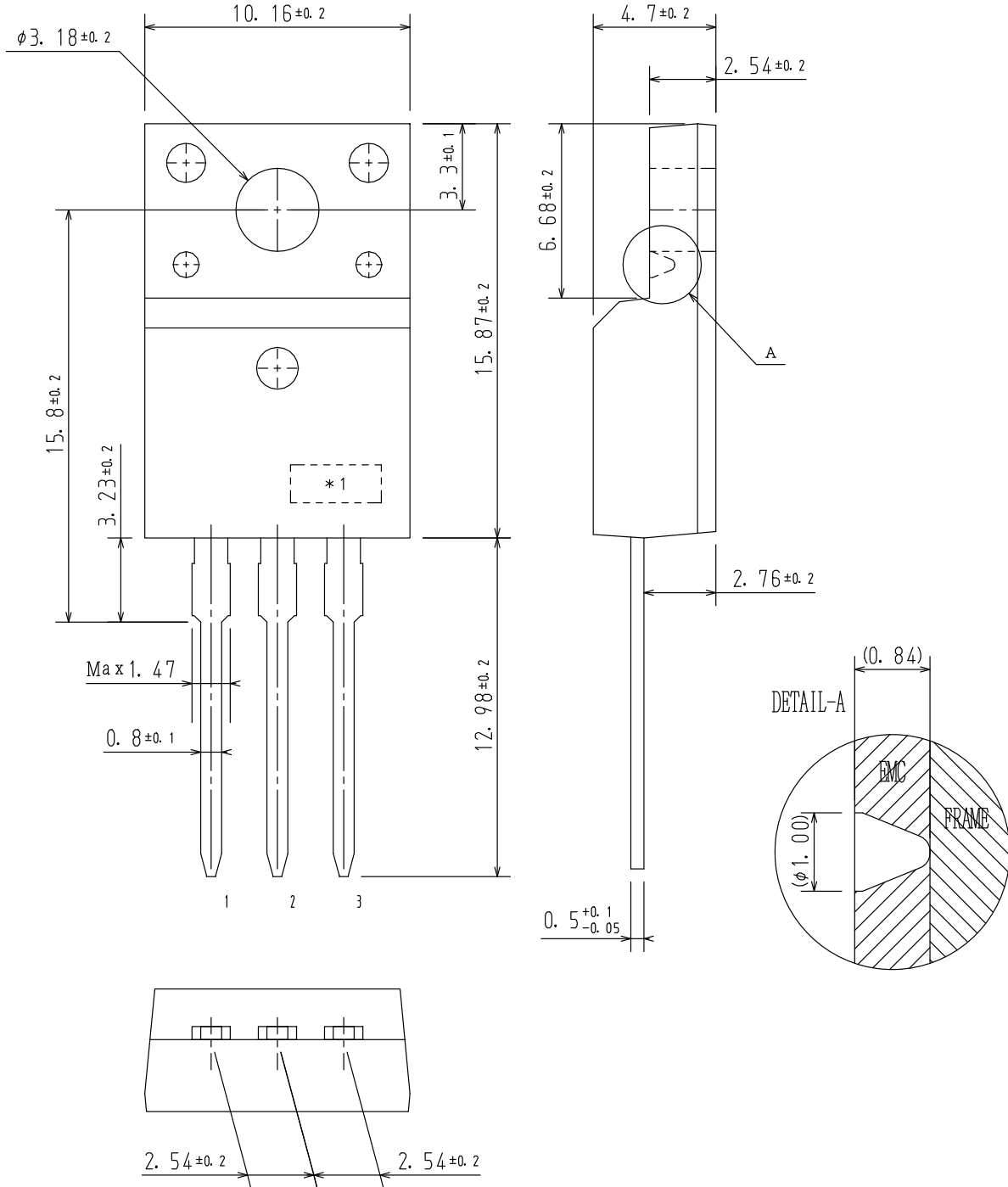

| | | |
|-------------------------|--|--|
| DOCUMENT NUMBER: | 98AON67439E | Electronic versions are uncontrolled except when accessed directly from the Document Repository. Printed versions are uncontrolled except when stamped "CONTROLLED COPY" in red. |
| STATUS: | ON SEMICONDUCTOR STANDARD | |
| NEW STANDARD: | | |
| DESCRIPTION: | TO-220 FULLPACK, 3-LEAD / TO-220F-3SG | PAGE 1 OF 2 |

MECHANICAL CASE OUTLINE

PACKAGE DIMENSIONS

ON Semiconductor®



TO-220-3LD CASE 340AT ISSUE A

DATE 03 OCT 2017

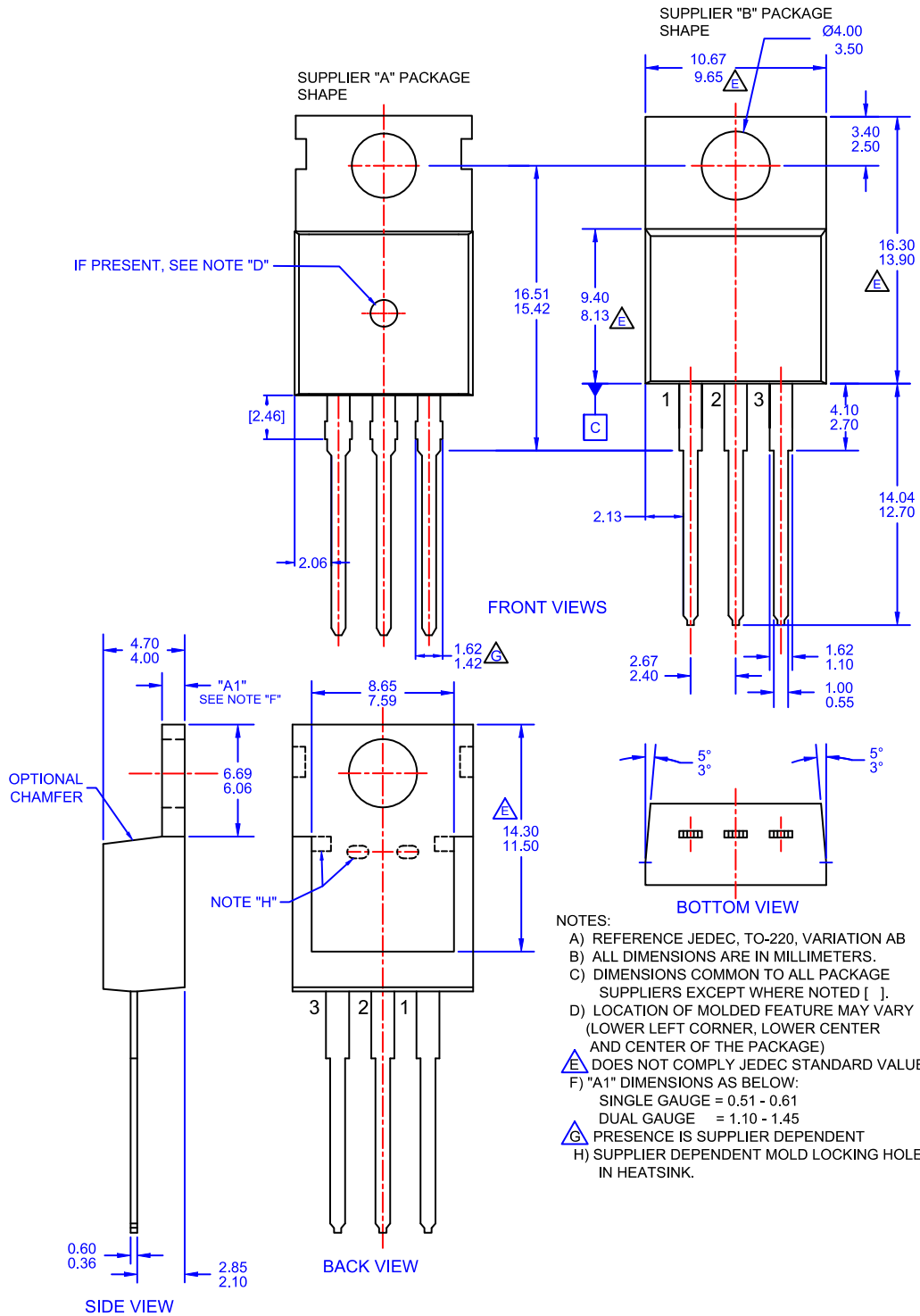

| | | |
|-------------------------|----------------------------------|--|
| DOCUMENT NUMBER: | 98AON13818G | Electronic versions are uncontrolled except when accessed directly from the Document Repository. Printed versions are uncontrolled except when stamped "CONTROLLED COPY" in red. |
| STATUS: | ON SEMICONDUCTOR STANDARD | |
| NEW STANDARD: | | |
| DESCRIPTION: | TO-220-3LD | PAGE 1 OF 2 |

ON Semiconductor and  are trademarks of Semiconductor Components Industries, LLC dba ON Semiconductor or its subsidiaries in the United States and/or other countries. ON Semiconductor owns the rights to a number of patents, trademarks, copyrights, trade secrets, and other intellectual property. A listing of ON Semiconductor's product/patent coverage may be accessed at www.onsemi.com/site/pdf/Patent-Marking.pdf. ON Semiconductor reserves the right to make changes without further notice to any products herein. ON Semiconductor makes no warranty, representation or guarantee regarding the suitability of its products for any particular purpose, nor does ON Semiconductor assume any liability arising out of the application or use of any product or circuit, and specifically disclaims any and all liability, including without limitation special, consequential or incidental damages. Buyer is responsible for its products and applications using ON Semiconductor products, including compliance with all laws, regulations and safety requirements or standards, regardless of any support or applications information provided by ON Semiconductor. "Typical" parameters which may be provided in ON Semiconductor data sheets and/or specifications can and do vary in different applications and actual performance may vary over time. All operating parameters, including "Typicals" must be validated for each customer application by customer's technical experts. ON Semiconductor does not convey any license under its patent rights nor the rights of others. ON Semiconductor products are not designed, intended, or authorized for use as a critical component in life support systems or any FDA Class 3 medical devices or medical devices with a same or similar classification in a foreign jurisdiction or any devices intended for implantation in the human body. Should Buyer purchase or use ON Semiconductor products for any such unintended or unauthorized application, Buyer shall indemnify and hold ON Semiconductor and its officers, employees, subsidiaries, affiliates, and distributors harmless against all claims, costs, damages, and expenses, and reasonable attorney fees arising out of, directly or indirectly, any claim of personal injury or death associated with such unintended or unauthorized use, even if such claim alleges that ON Semiconductor was negligent regarding the design or manufacture of the part. ON Semiconductor is an Equal Opportunity/Affirmative Action Employer. This literature is subject to all applicable copyright laws and is not for resale in any manner.

PUBLICATION ORDERING INFORMATION

LITERATURE FULFILLMENT:

Literature Distribution Center for ON Semiconductor
19521 E. 32nd Pkwy, Aurora, Colorado 80011 USA
Phone: 303-675-2175 or 800-344-3860 Toll Free USA/Canada
Fax: 303-675-2176 or 800-344-3867 Toll Free USA/Canada
Email: orderlit@onsemi.com

N. American Technical Support: 800-282-9855 Toll Free
USA/Canada
Europe, Middle East and Africa Technical Support:
Phone: 421 33 790 2910

ON Semiconductor Website: www.onsemi.com

Order Literature: <http://www.onsemi.com/orderlit>

For additional information, please contact your local
Sales Representative