

Automotive-grade N-channel 80 V, 1.7 mΩ typ., 180 A, STripFET™ F7 Power MOSFETs in H<sup>2</sup>PAK-2 and H<sup>2</sup>PAK-6

Datasheet - production data

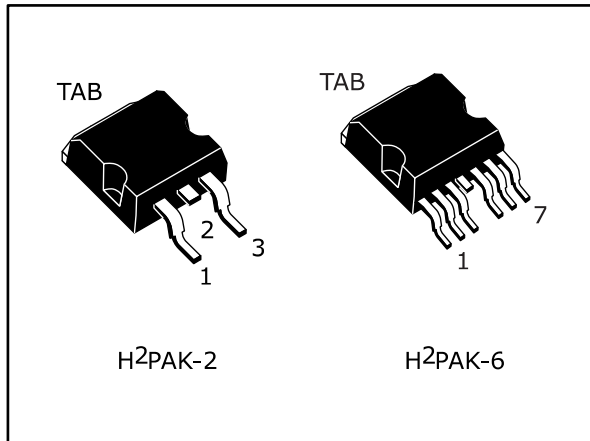
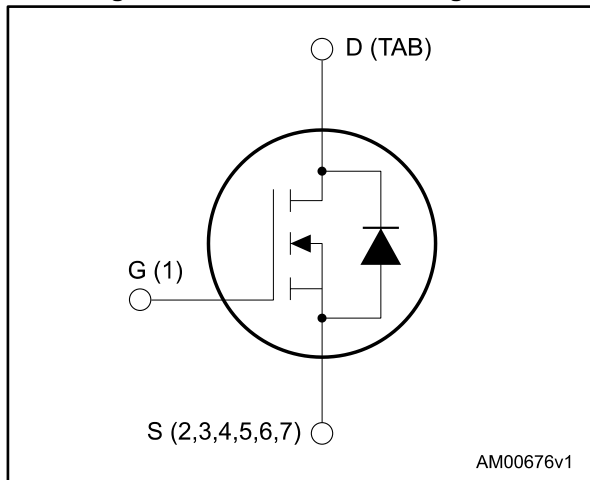

Figure 1: Internal schematic diagram



## Features

Order code	V <sub>DS</sub>	R <sub>DS(on)</sub> max.	I <sub>D</sub>
STH275N8F7-2AG	80 V	2.1 mΩ	180 A
STH275N8F7-6AG			

- AEC-Q101 qualified
- Among the lowest R<sub>DS(on)</sub> on the market
- Excellent FoM (figure of merit)
- Low C<sub>rss</sub>/C<sub>iss</sub> ratio for EMI immunity
- High avalanche ruggedness



## Applications

- Switching applications

## Description

These N-channel Power MOSFETs utilize STripFET™ F7 technology with an enhanced trench gate structure that results in very low on-state resistance, while also reducing internal capacitance and gate charge for faster and more efficient switching.

Table 1: Device summary

Order code	Marking	Package	Packing
STH275N8F7-2AG	275N8F7	H <sup>2</sup> PAK-2	Tape and reel
STH275N8F7-6AG		H <sup>2</sup> PAK-6	

---

# Contents

<b>1</b>	<b>Electrical ratings .....</b>	<b>3</b>
<b>2</b>	<b>Electrical characteristics .....</b>	<b>4</b>
	2.1 Electrical characteristics (curves) .....	6
<b>3</b>	<b>Test circuits .....</b>	<b>8</b>
<b>4</b>	<b>Package information .....</b>	<b>9</b>
	4.1 H <sup>2</sup> PAK-2 package information.....	10
	4.2 H <sup>2</sup> PAK-6 package information.....	12
	4.3 H <sup>2</sup> PAK packing information .....	15
<b>5</b>	<b>Revision history .....</b>	<b>17</b>



# 1 Electrical ratings

**Table 2: Absolute maximum ratings**

Symbol	Parameter	Value	Unit
$V_{DS}$	Drain-source voltage	80	V
$V_{GS}$	Gate-source voltage	$\pm 20$	V
$I_D^{(1)}$	Drain current (continuous) at $T_C = 25\text{ }^\circ\text{C}$	180	A
	Drain current (continuous) at $T_C = 100\text{ }^\circ\text{C}$	180	
$I_{DM}^{(2)}$	Drain current (pulsed)	720	A
$P_{TOT}$	Total dissipation at $T_C = 25\text{ }^\circ\text{C}$	315	W
$E_{AS}^{(3)}$	Single pulse avalanche energy	0.775	J
$T_{stg}$	Storage temperature range	-55 to 175	$^\circ\text{C}$
$T_j$	Operating junction temperature range		

**Notes:**

- (1) Limited by package.
- (2) Pulse width is limited by safe operating area.
- (3) Starting  $T_j = 25\text{ }^\circ\text{C}$ ,  $I_d = 65\text{ A}$ ,  $V_{dd} = 50\text{ V}$ ,  $T_j < T_{j-max}$ .

**Table 3: Thermal data**

Symbol	Parameter	Value	Unit
$R_{thj-case}$	Thermal resistance junction-case	0.48	$^\circ\text{C/W}$
$R_{thj-pcb}^{(1)}$	Thermal resistance junction-pcb	35	

**Notes:**

- (1) When mounted on FR-4 board of 1 inch<sup>2</sup>, 2oz Cu.

## 2 Electrical characteristics

(T<sub>CASE</sub> = 25 °C unless otherwise specified)

**Table 4: On/off states**

Symbol	Parameter	Test conditions	Min.	Typ.	Max.	Unit
V <sub>(BR)DSS</sub>	Drain-source breakdown voltage	V <sub>GS</sub> = 0 V, I <sub>D</sub> = 1 mA	80			V
I <sub>DSS</sub>	Zero gate voltage drain current	V <sub>GS</sub> = 0 V, V <sub>DS</sub> = 80 V			1	μA
		V <sub>GS</sub> = 0 V, V <sub>DS</sub> = 80 V, T <sub>C</sub> = 125 °C <sup>(1)</sup>			100	
I <sub>GSS</sub>	Gate-body leakage current	V <sub>DS</sub> = 0 V, V <sub>GS</sub> = +20 V			100	nA
V <sub>GS(th)</sub>	Gate threshold voltage	V <sub>DS</sub> = V <sub>GS</sub> , I <sub>D</sub> = 250 μA	2.5		4.5	V
R <sub>DS(on)</sub>	Static drain-source on-resistance	V <sub>GS</sub> = 10 V, I <sub>D</sub> = 90 A		1.7	2.1	mΩ

**Notes:**

<sup>(1)</sup> Defined by design, not subject to production test.

**Table 5: Dynamic**

Symbol	Parameter	Test conditions	Min.	Typ.	Max.	Unit
C <sub>iss</sub>	Input capacitance	V <sub>DS</sub> = 50 V, f = 1 MHz, V <sub>GS</sub> = 0 V	-	13600	-	pF
C <sub>oss</sub>	Output capacitance		-	2050	-	
C <sub>rss</sub>	Reverse transfer capacitance		-	236	-	
Q <sub>g</sub>	Total gate charge	V <sub>DD</sub> = 40 V, I <sub>D</sub> = 180 A, V <sub>GS</sub> = 10 V (see <a href="#">Figure 14: "Test circuit for gate charge behavior"</a> )	-	193	-	nC
Q <sub>gs</sub>	Gate-source charge		-	96	-	
Q <sub>gd</sub>	Gate-drain charge		-	46	-	

**Table 6: Switching times**

Symbol	Parameter	Test conditions	Min.	Typ.	Max.	Unit
t <sub>d(on)</sub>	Turn-on delay time	V <sub>DD</sub> = 40 V, I <sub>D</sub> = 90 A R <sub>G</sub> = 4.7 Ω, V <sub>GS</sub> = 10 V (see <a href="#">Figure 18: "Switching time waveform"</a> )	-	56	-	ns
t <sub>r</sub>	Rise time		-	180	-	
t <sub>d(off)</sub>	Turn-off delay time		-	98	-	
t <sub>f</sub>	Fall time		-	42	-	

Table 7: Source-drain diode

Symbol	Parameter	Test conditions	Min.	Typ.	Max.	Unit
$I_{SD}$	Source-drain current		-		180	A
$I_{SDM}^{(1)}$	Source-drain current (pulsed)		-		720	A
$V_{SD}^{(2)}$	Forward on voltage	$V_{GS} = 0\text{ V}, I_{SD} = 90\text{ A}$	-		1.2	V
$t_{rr}$	Reverse recovery time	$I_{SD} = 180\text{ A}, di/dt = 100\text{ A}/\mu\text{s}, V_{DD} = 64\text{ V}, T_j = 150\text{ }^\circ\text{C}$	-	78		ns
$Q_{rr}$	Reverse recovery charge		-	182		nC
$I_{RRM}$	Reverse recovery current		-	4.7		A

**Notes:**

- (1) Pulse width limited by safe operating area.
- (2) Pulsed: pulse duration = 300  $\mu\text{s}$ , duty cycle 1.5 %.

## 2.1 Electrical characteristics (curves)

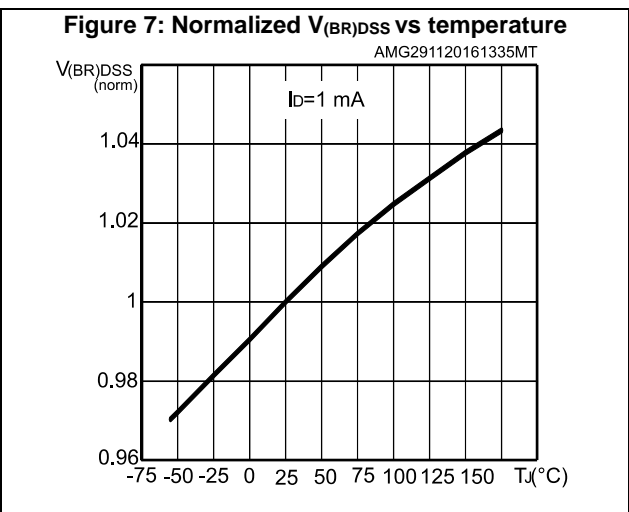
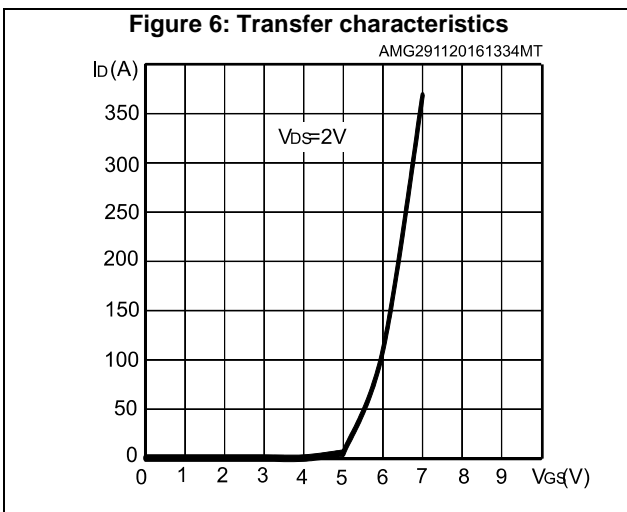
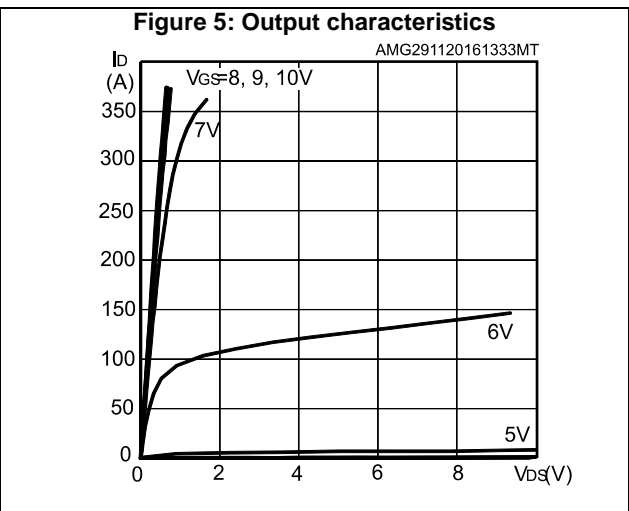
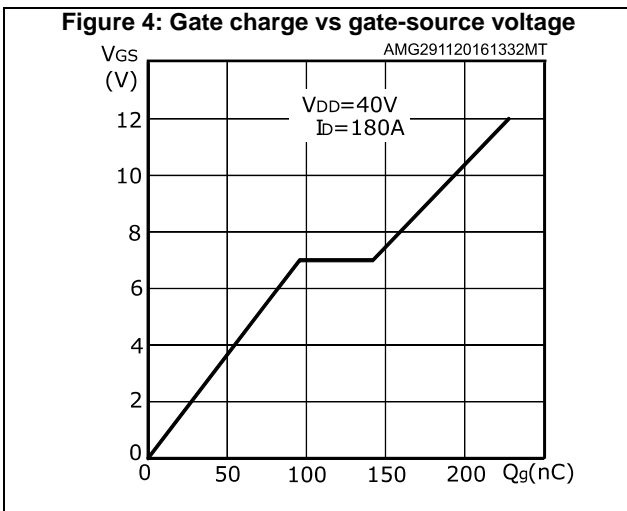
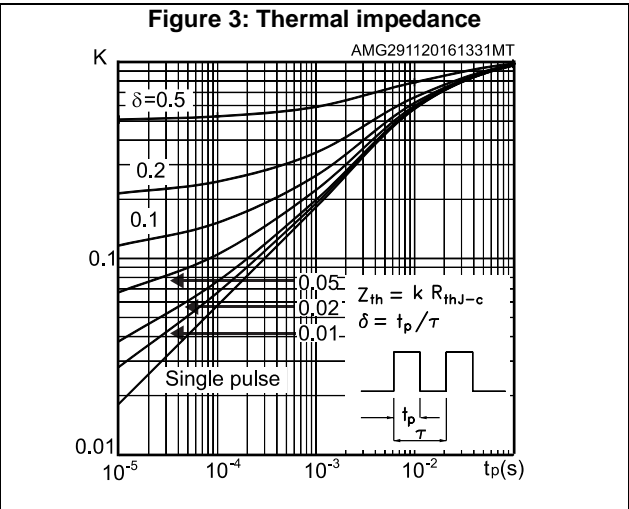
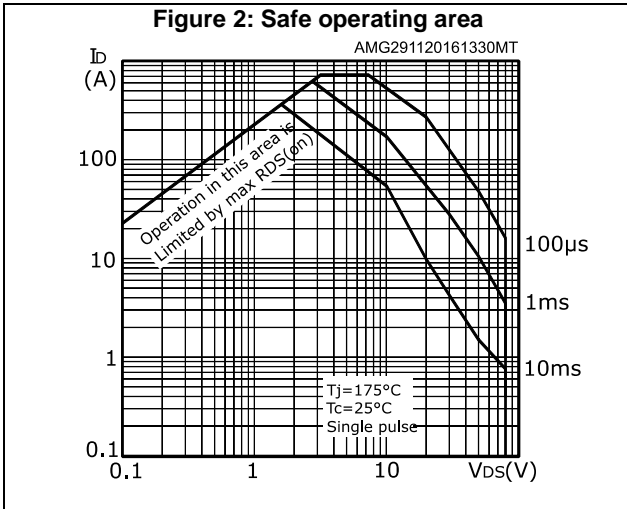

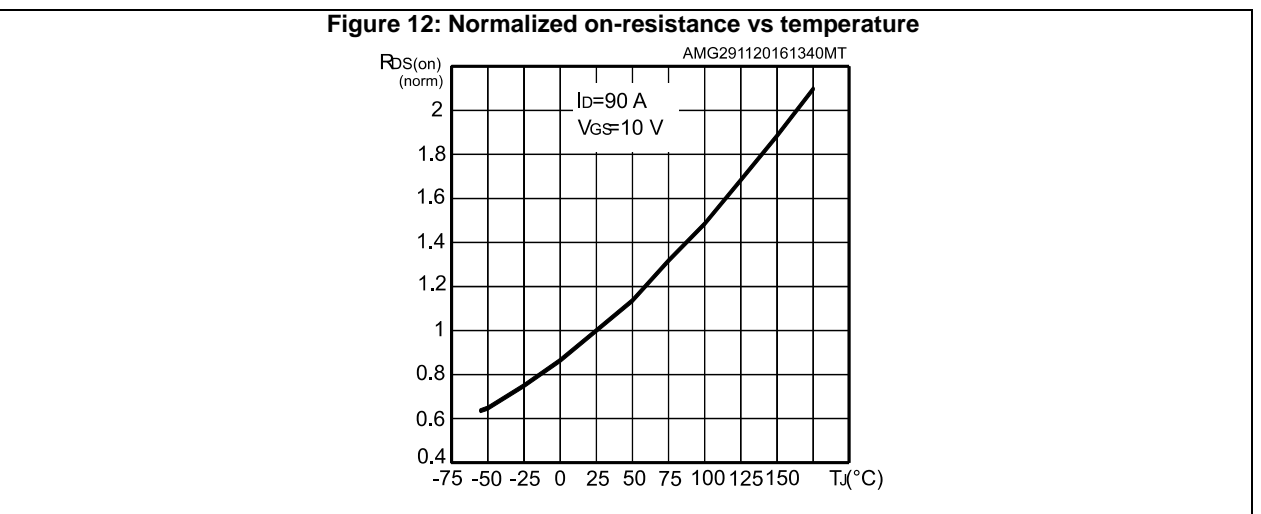
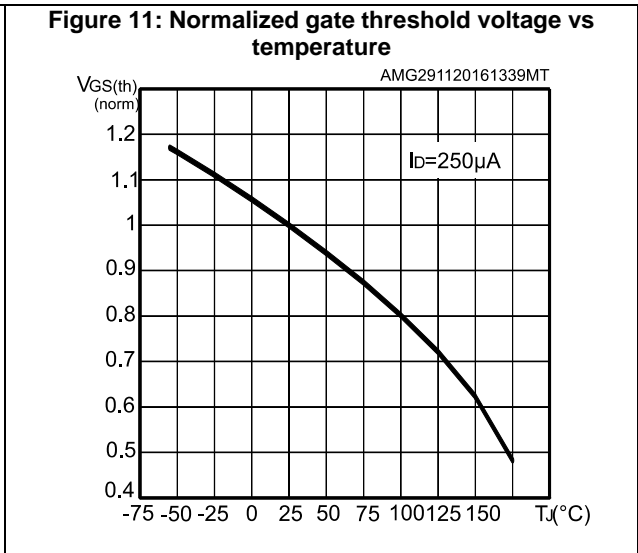
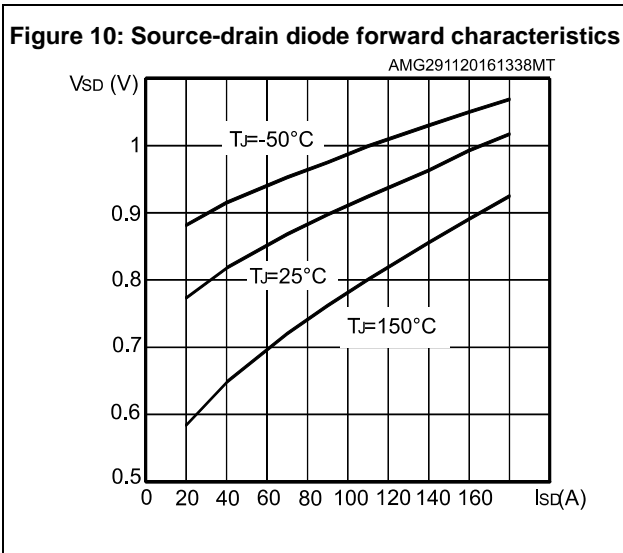
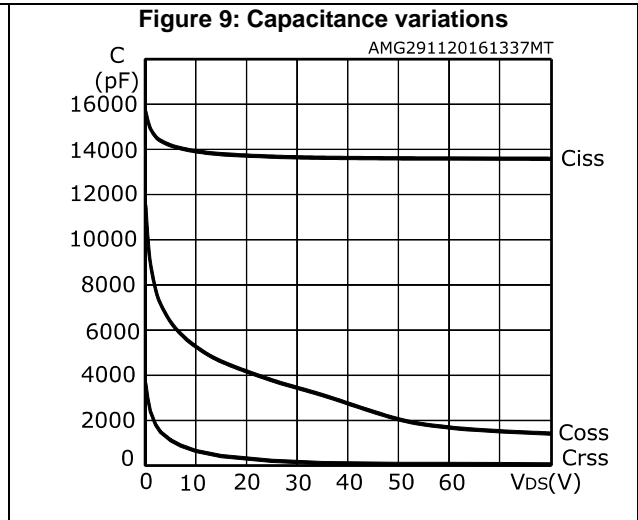
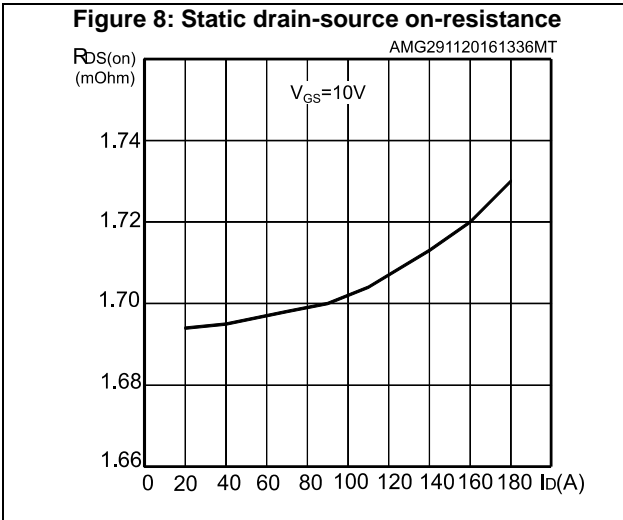

### 3 Test circuits

**Figure 13: Test circuit for resistive load switching times**

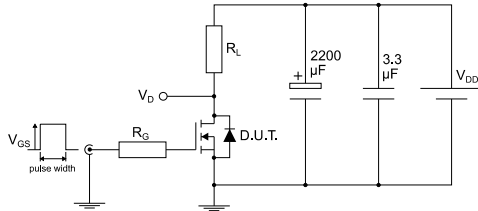

AM01468v1

**Figure 14: Test circuit for gate charge behavior**

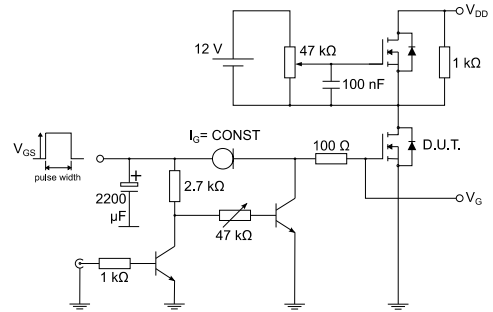

AM01469v1

**Figure 15: Test circuit for inductive load switching and diode recovery times**

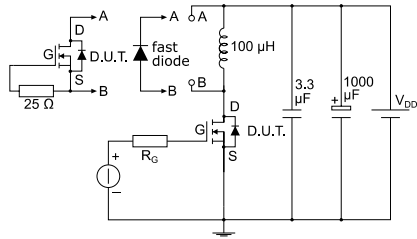

AM01470v1

**Figure 16: Unclamped inductive load test circuit**

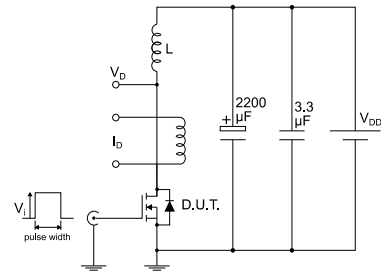

AM01471v1

**Figure 17: Unclamped inductive waveform**

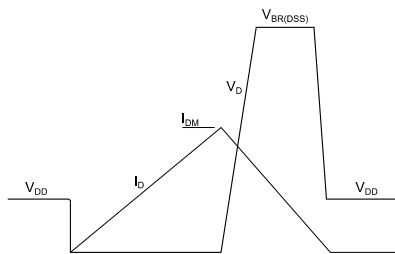

AM01472v1

**Figure 18: Switching time waveform**

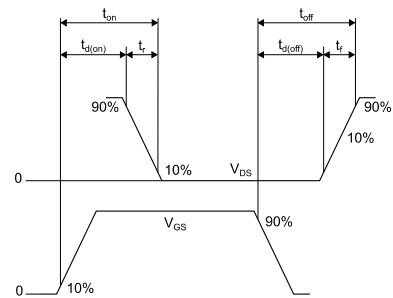

AM01473v1



## 4 Package information

In order to meet environmental requirements, ST offers these devices in different grades of ECOPACK® packages, depending on their level of environmental compliance. ECOPACK® specifications, grade definitions and product status are available at: [www.st.com](http://www.st.com). ECOPACK® is an ST trademark.

### 4.1 H<sup>2</sup>PAK-2 package information

Figure 19: H<sup>2</sup>PAK-2 package outline

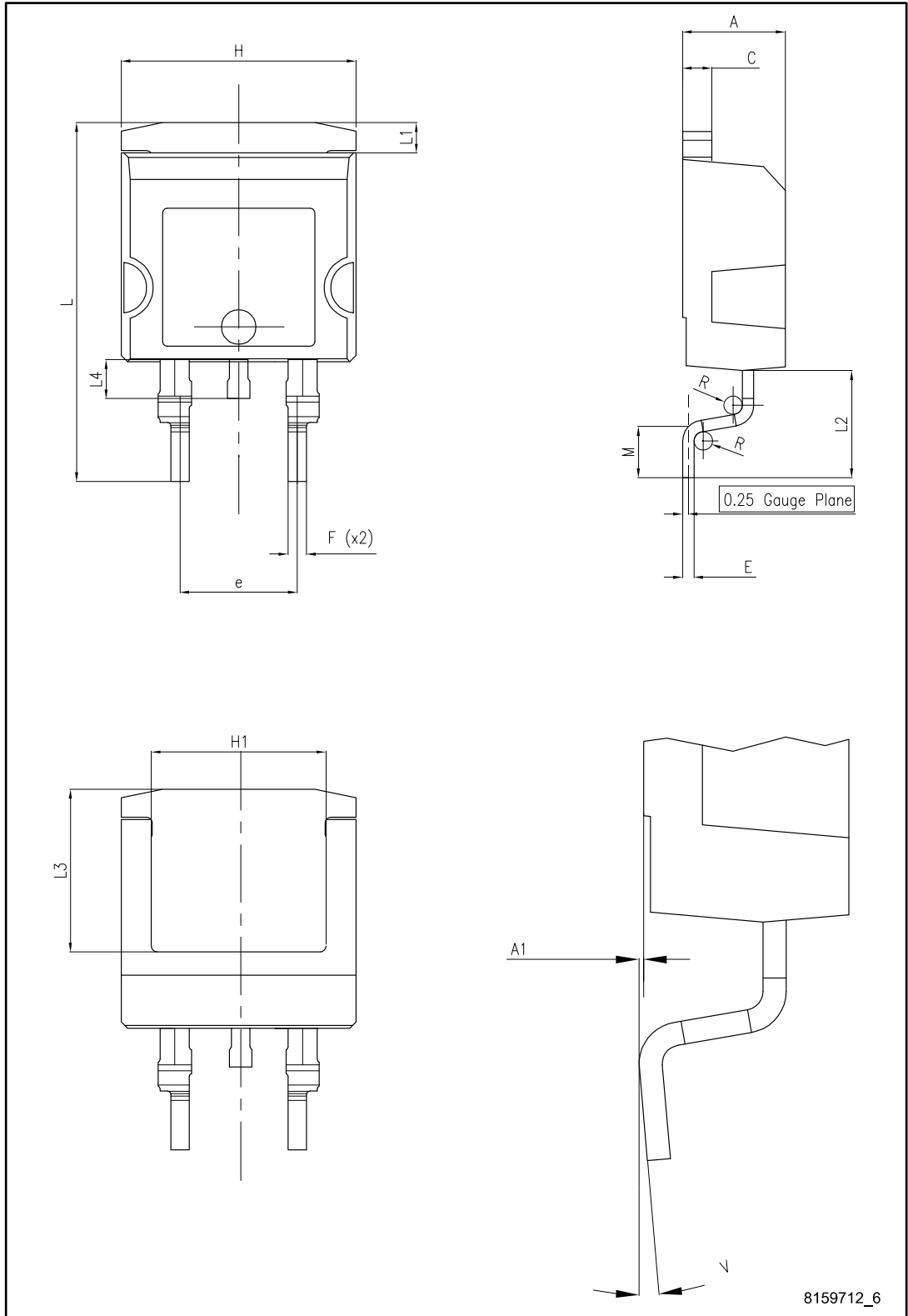
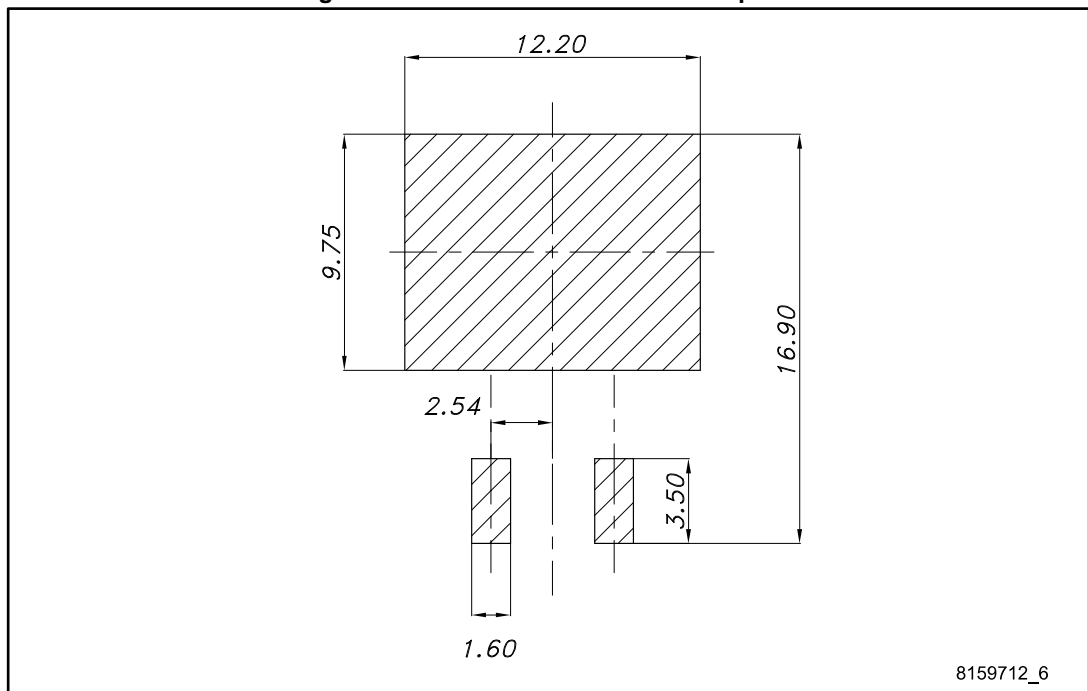

Table 8: H<sup>2</sup>PAK-2 package mechanical data

Dim.	mm		
	Min.	Typ.	Max.
A	4.30		4.70
A1	0.03		0.20
C	1.17		1.37
e	4.98		5.18
E	0.50		0.90
F	0.78		0.85
H	10.00		10.40
H1	7.40		7.80
L	15.30		15.80
L1	1.27		1.40
L2	4.93		5.23
L3	6.85		7.25
L4	1.5		1.7
M	2.6		2.9
R	0.20		0.60
V	0°		8°

Figure 20: H<sup>2</sup>PAK-2 recommended footprint



### 4.2 H<sup>2</sup>PAK-6 package information

Figure 21: H<sup>2</sup>PAK-6 package outline

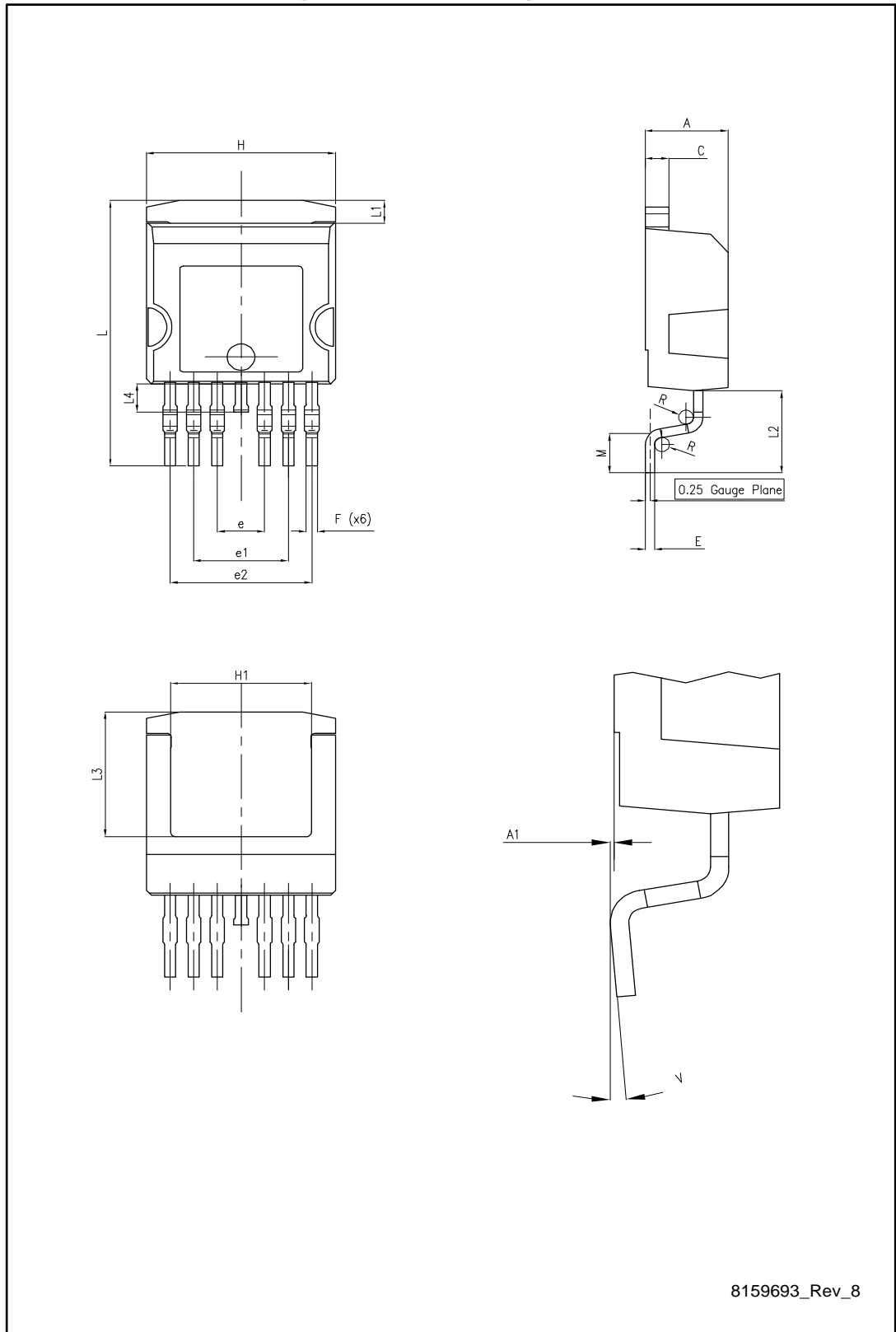

8159693\_Rev\_8

Table 9: H<sup>2</sup>PAK-6 package mechanical data

Dim.	mm		
	Min.	Typ.	Max.
A	4.30		4.70
A1	0.03		0.20
C	1.17		1.37
e	2.34	2.54	2.74
e1	4.88		5.28
e2	7.42		7.82
E	0.45		0.60
F	0.50		0.70
H	10.00		10.40
H1	7.40		7.80
L	14.75		15.25
L1	1.27		1.40
L2	4.35		4.95
L3	6.85		7.25
L4	1.50		1.75
M	1.90		2.50
R	0.20		0.60
V	0°		8°

Figure 22: H<sup>2</sup>PAK-6 recommended footprint

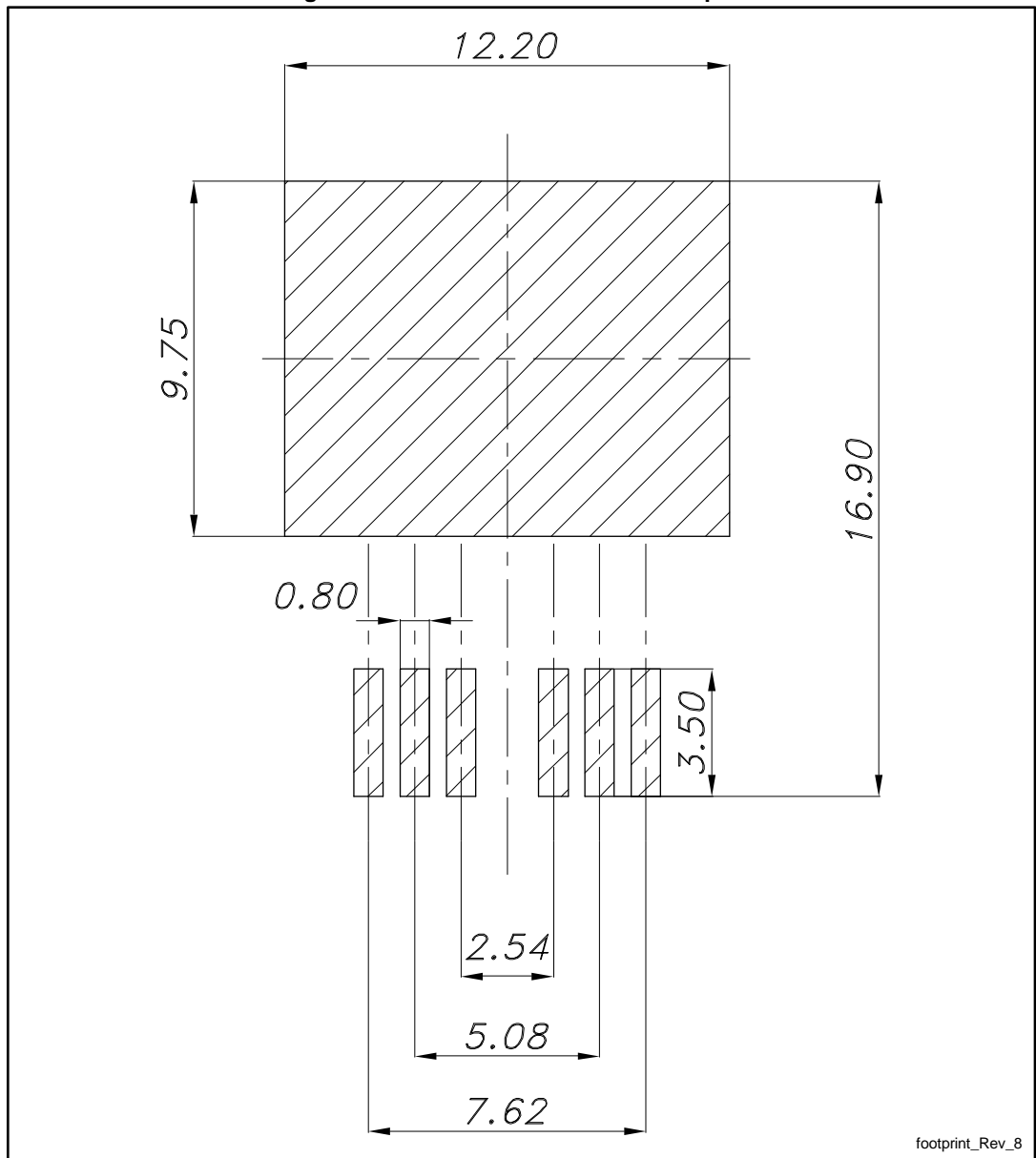

footprint\_Rev\_8



Dimensions are in mm.

### 4.3 H<sup>2</sup>PAK packing information

Figure 23: Tape outline

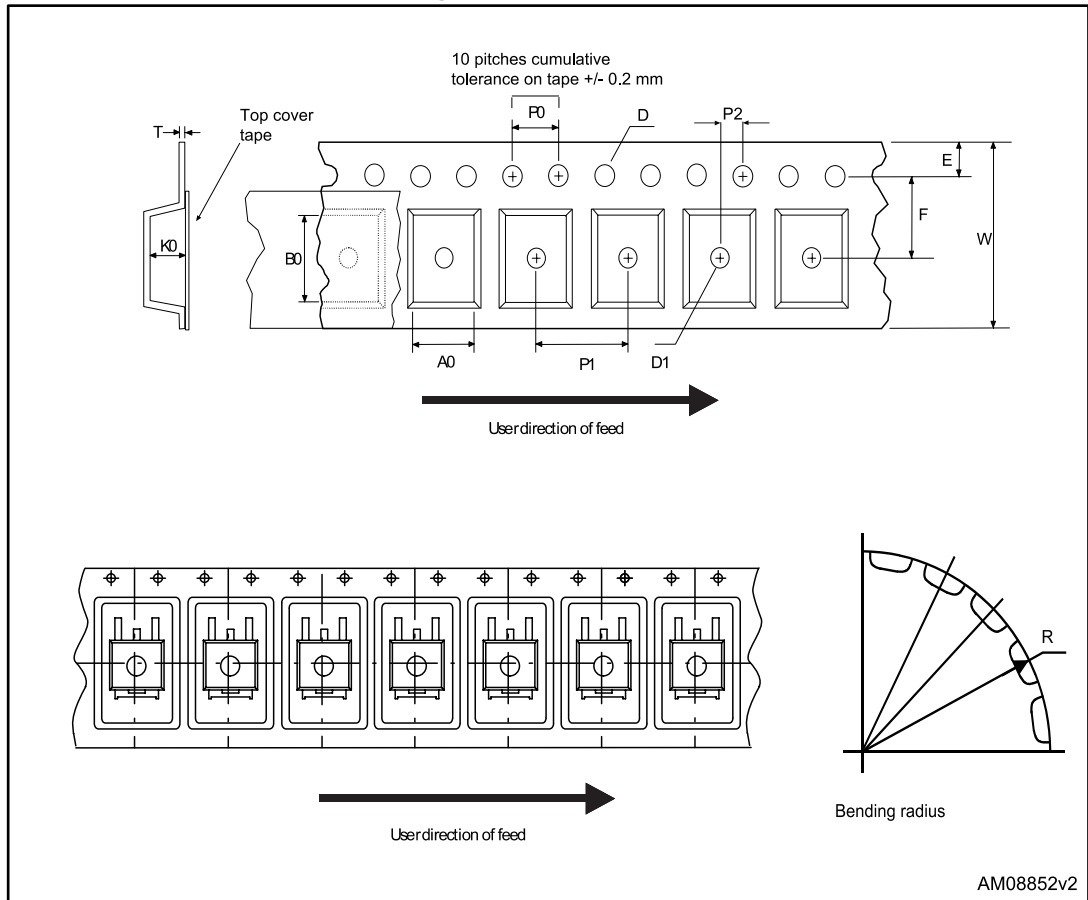

Figure 24: Reel outline

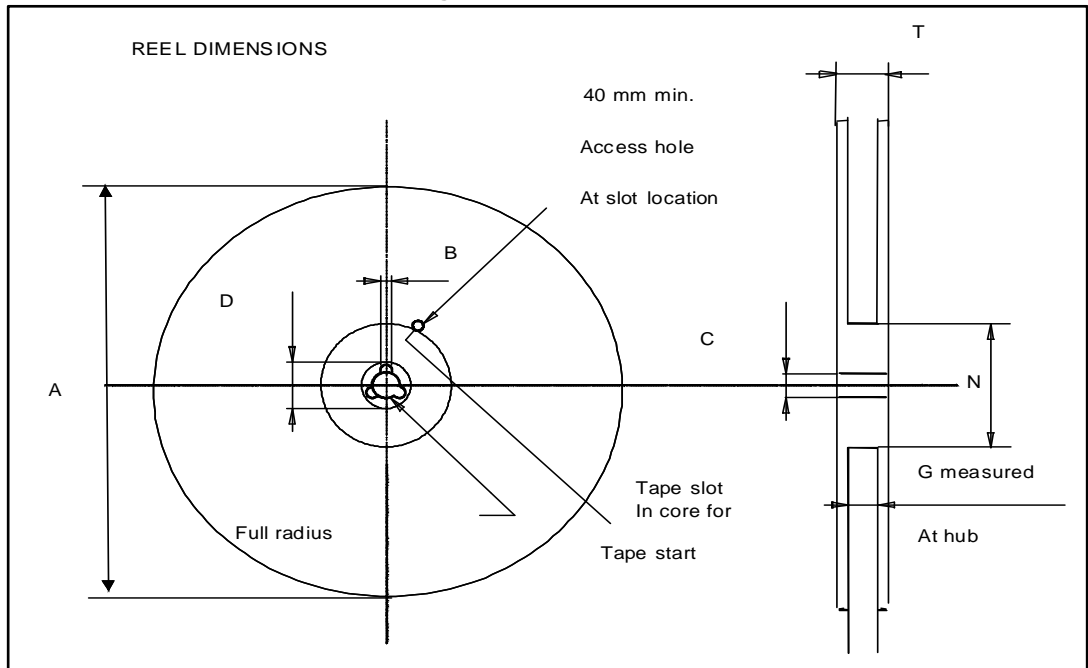

Table 10: Tape and reel mechanical data

Tape			Reel		
Dim.	mm		Dim.	mm	
	Min.	Max.		Min.	Max.
A0	10.5	10.7	A		330
B0	15.7	15.9	B	1.5	
D	1.5	1.6	C	12.8	13.2
D1	1.59	1.61	D	20.2	
E	1.65	1.85	G	24.4	26.4
F	11.4	11.6	N	100	
K0	4.8	5.0	T		30.4
P0	3.9	4.1			
P1	11.9	12.1	Base quantity		1000
P2	1.9	2.1	Bulk quantity		1000
R	50				
T	0.25	0.35			
W	23.7	24.3			



## 5 Revision history

**Table 11: Document revision history**

Date	Revision	Changes
27-Nov-2014	1	First release.
05-Mar-2015	2	Document status promoted from preliminary to production data. Updated title and feature in cover page.
10-Mar-2016	3	Updated Table 4. Minor text changes.
10-Jan-2017	4	Updated title and features in cover page. Updated <a href="#">Table 2: "Absolute maximum ratings"</a> , <a href="#">Table 4: "On/off states"</a> and <a href="#">Table 6: "Switching times"</a> . Minor text changes.

**IMPORTANT NOTICE – PLEASE READ CAREFULLY**

STMicroelectronics NV and its subsidiaries ("ST") reserve the right to make changes, corrections, enhancements, modifications, and improvements to ST products and/or to this document at any time without notice. Purchasers should obtain the latest relevant information on ST products before placing orders. ST products are sold pursuant to ST's terms and conditions of sale in place at the time of order acknowledgement.

Purchasers are solely responsible for the choice, selection, and use of ST products and ST assumes no liability for application assistance or the design of Purchasers' products.

No license, express or implied, to any intellectual property right is granted by ST herein.

Resale of ST products with provisions different from the information set forth herein shall void any warranty granted by ST for such product.

ST and the ST logo are trademarks of ST. All other product or service names are the property of their respective owners.

Information in this document supersedes and replaces information previously supplied in any prior versions of this document.

© 2017 STMicroelectronics – All rights reserved