

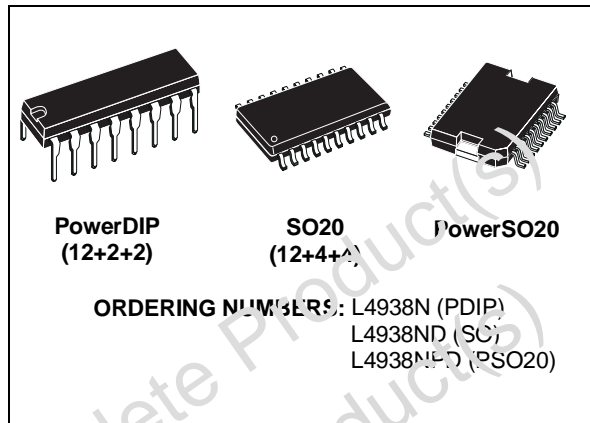

L4938N/ND L4938NPD

DUAL MULTIFUNCTION VOLTAGE REGULATOR

- STANDBY OUTPUT VOLTAGE PRECISION 5V ± 2%
- OUTPUT 2 TRACKED TO THE STANDBY OUTPUT
- OUTPUT 2 DISABLE FUNCTION FOR STANDBY MODE
- VERY LOW QUIESCENT CURRENT, LESS THAN 250μA, IN STANDBY MODE
- OUTPUT 2 VOLTAGE SETTABLE FROM 5 TO 20V
- OUTPUT CURRENTS : I_{o1} = 50mA, I_{o2} = 500mA
- VERY LOW DROPOUT (max 0.4V/0.6V)
- OPERATING TRANSIENT SUPPLY VOLTAGE UP TO 40V
- POWER-ON RESET CIRCUIT SENSING THE STANDBY OUTPUT VOLTAGE
- POWER-ON RESET DELAY PULSE DEFINED BY THE EXTERNAL CAPACITOR
- EARLY WARNING OUTPUT FOR SUPPLY UNDERVOLTAGE
- THERMAL SHUTDOWN AND SHORT CIRCUIT PROTECTIONS



DESCRIPTION

The L4938N is a monolithic integrated dual voltage regulators with two very low dropout outputs and additional functions such as power-on reset and input voltage sense. They are designed for supplying microcomputer controlled systems specially in automotive applications.

PIN CONNECTION (top view)

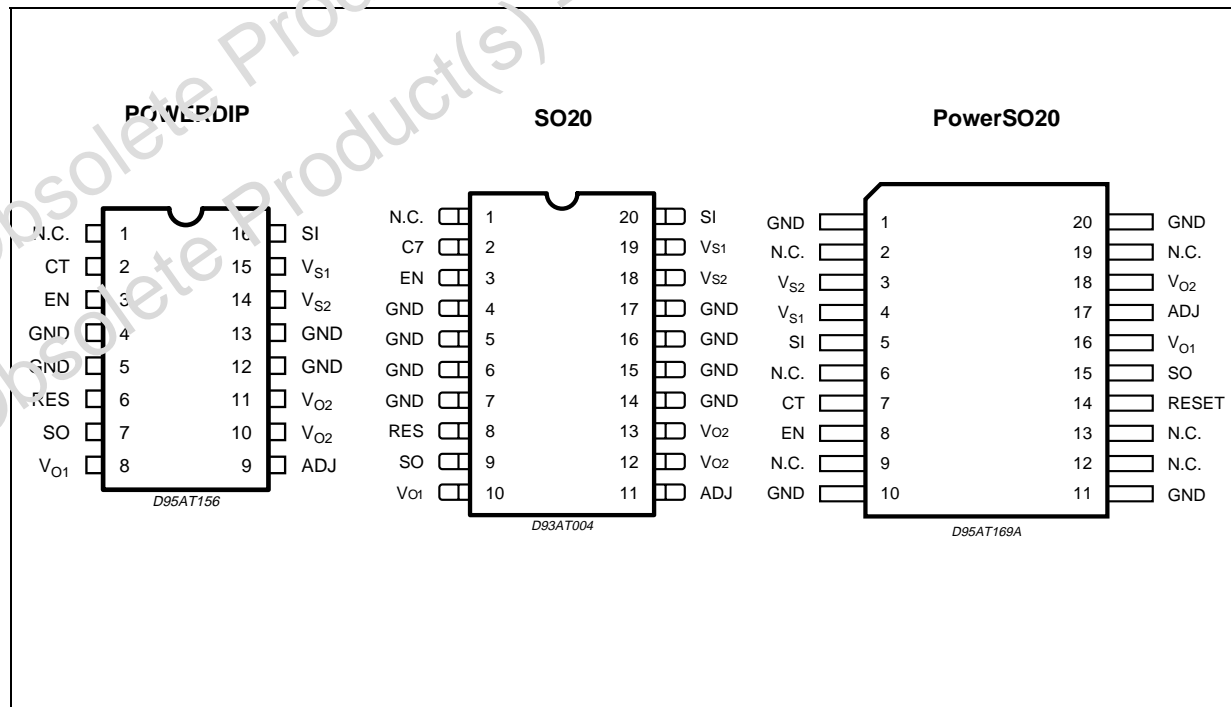

BLOCK DIAGRAM

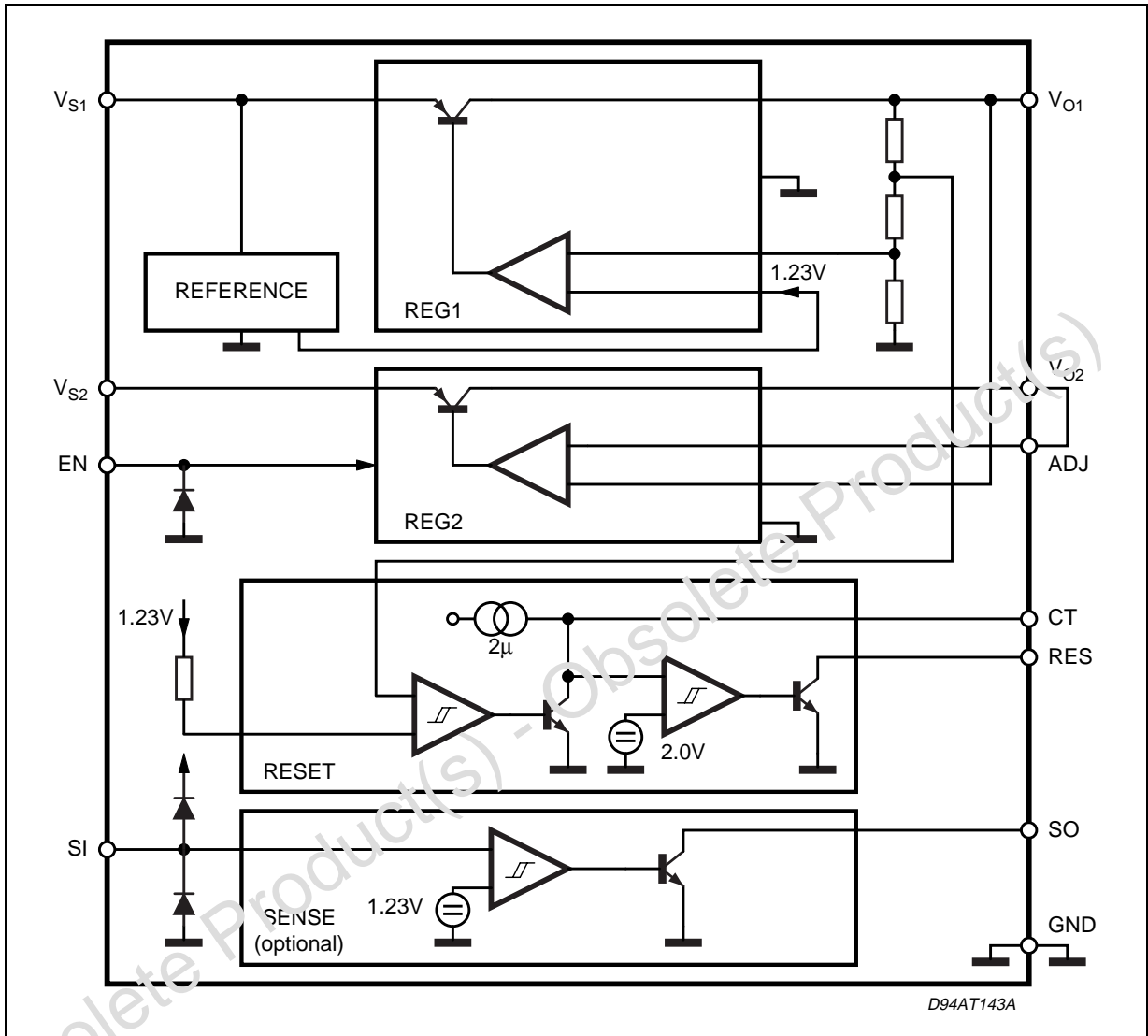

TEMPERAL DATA

Symbol	Parameter		Powerdip	PowerSO20	SO20	Unit
R _{thj-case}	Thermal Resistance Junction-Case	Max.	14	< 2	-	°C/W
R _{thj-amb}	Thermal Resistance Junction-Ambient	Max.	90	-	20	°C/W

ABSOLUTE MAXIMUM RATINGS

Symbol	Parameter	Value	Unit
V_S	DC Supply Voltage	28	V
	Transient Supply Voltage ($T < 1s$)	40	V
T_j, T_{stg}	Junction and Storage Temperature Range	-55 to 150	°C
I_{SI}	Sense Input Current ($V_{SI} \leq 0.3V$ or $V_{SI} > V_S$)	± 1	mA
I_{EN}	Enable Input Current ($V_{EN} \leq 0.3V$)	± 1	mA
V_{EN}	Enable Input Voltage	V_S	
V_{RES}, V_{SO}	Reset and Sense Output Voltage	20	V
I_{RES}, I_{SO}	Reset and Sense Output Current	5	mA
P_D	Power Dissipation	875	mW

Note : The circuit is ESD protected according to MIL-STD-883C.

APPLICATION CIRCUIT

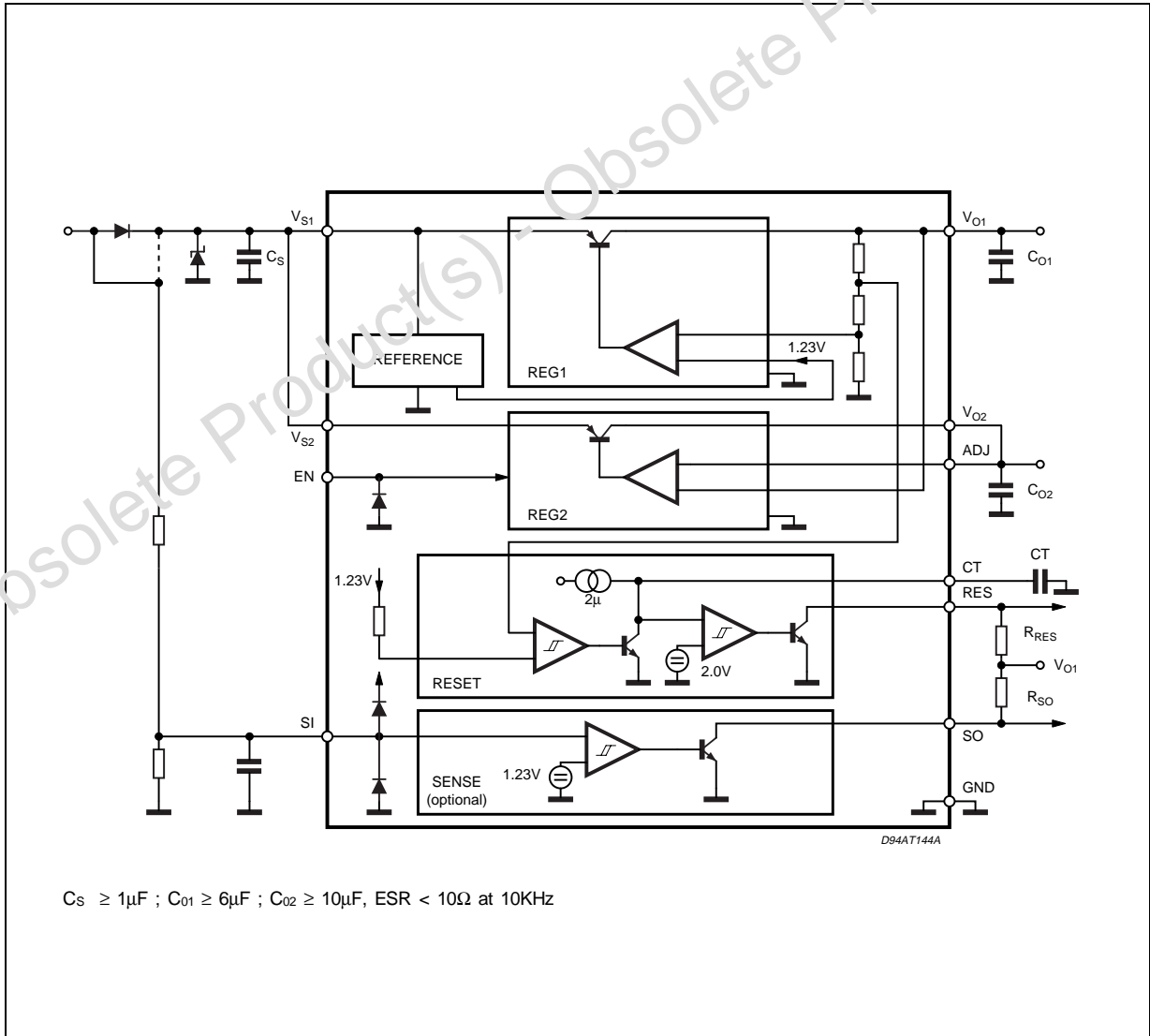

L4938N - L4938ND - L4938NPD

ELECTRICAL CHARACTERISTICS ($V_S = 14V$; $-40^\circ C \leq T_J \leq 125^\circ C$ unless otherwise specified)

Symbol	Parameter	Test Conditions	Min.	Typ.	Max.	Unit
V_S	Operating Supply Voltage				25	V
V_{O1}	Standby Output Voltage	$6V \leq V_S \leq 25V$ $1mA \leq I_{O1} \leq 50mA$	4.90	5.00	5.10	V
$V_{O2} - V_{O1}$	Output Voltage 2 Tracking Error (note 1)	$6V \leq V_S \leq 25V$ $5mA \leq I_{O2} \leq 500mA$ Enable = LOW	-25		+25	mV
I_{ADJ}	ADJ Input Current	$I_{O1} = 1mA$; $I_{O2} = 5mA$	-1	0.1	1	μA
V_{DP1}	Dropout Voltage 1	$I_{O1} = 10mA$ $I_{O1} = 50mA$		0.1 0.2	0.25 0.4	V V
V_{IO1}	Input to Output Voltage Difference in Undervoltage Condition	$V_S = 4V$, $I_{O1} = 35mA$			0.4	V
V_{DP2}	Dropout Voltage 2	$I_{O1} = 100mA$ $I_{O1} = 500mA$		0.2 0.3	0.3 0.6	V V
V_{IO2}	Input to Output Voltage Difference in Undervoltage Condition	$V_S = 4.6V$, $I_{O1} = 350mA$			0.6	V
$V_{OL1,2}$	Line Regulation	$6V \leq V_S \leq 25V$ $I_{O1} = 1mA$; $I_{O2} = 5mA$			20	mV
V_{OLO1}	Load Regulation 1	$1mA \leq I_{O1} \leq 50mA$			25	mV
V_{OLO2}	Load Regulation 2	$5mA \leq I_{O2} \leq 500mA$			50	mV
I_{LIM1}	Current Limit 1	$V_{O1} = 4.5V$ $V_{O1} = 0V$ (note 2)	55 25	100 50	200 100	mA mA
I_{LIM2}	Current Limit 2	$V_{O2} = 0V$	550	1000	1700	mA
I_{QSB}	Quiescent Current Standby Mode (output 2 disabled)	$I_{O1} = 0.3mA$; $T_J < 100^\circ C$ $V_{EN} \geq 2.4V$ $V_S = 14V$ $V_S = 3.5V$		210 340	290 850	μA μA
I_Q	Quiescent Current	$I_{O1} = 50mA$ $I_{O1} = 500mA$			30	mA

ENABLE

V_{INL}	Enable Input LOW Voltage (output 2 active)		-0.3		1.5	V
V_{ENH}	Enable Input HIGH Voltage		2.4		7	V
V_{ENhyst}	Enable Hysteresis		30	75	200	mV
I_{EN}	Enable Input Current	$0V < V_{EN} < 1.2V$ $2.5V < V_{EN} < 7V$	-10 -1	-1.5 0	-0.5 +1	μA μA

ELECTRICAL CHARACTERISTICS (continued)**RESET**

Symbol	Parameter	Test Conditions	Min.	Typ.	Max.	Unit
V_{Rt}	Reset Low Threshold Voltage		$V_{O1} - 0.4$	4.7	$V_{O1} - 0.1$	V
V_{Rth}	Reset Threshold Hysteresis		50	100	200	mV
t_{RD}	Reset Pulse Delay	$C_T = 100\text{nF}$; $t_R > 100\mu\text{s}$	55	100	180	mV
t_{RR}	Reset Reaction Time	$C_T = 100\text{nF}$	1	10	50	μs
V_{RL}	Reset Output LOW Voltage	$R_{RES} = 10\text{K}\Omega$ to V_{O1} $V_S = 1.5\text{V}$			0.4	V
I_{LRES}	Reset Output HIGH Leakage	$V_{RES} = 5\text{V}$			1	μA
V_{CTh}	Delay Comparator Threshold			2.0		V
$V_{CTh, hyst}$	Delay Comparator Threshold Hysteresis			100		mV

SENSE

V_{Sth}	Sense Threshold Voltage		1.16	1.23	1.35	V
$V_{Sth, hyst}$	Sense Threshold Hysteresis		40	100	200	mV
V_{SOL}	Sense Output LOW Voltage	$V_{SI} = 1,16\text{V}$; $V_S \geq 3\text{V}$ $R_{SO} = 10\text{K}\Omega$ to V_{O1}			0.4	V
I_{LSO}	Sense Output Leakage	$V_{SO} = 5\text{V}$; $V_{SI} \geq 1.5\text{V}$			1	μA

Note : 1 : V_{O2} connected to ADJ. V_{O2} can be set to higher values by inserting an external resistor divider.
2 : Foldback characteristic

FUNCTIONAL DESCRIPTION

The L4938N is based on the ST Microelectronics modular voltage regulator approach. Several outstanding features and auxiliary functions are provided to meet the requirements of supplying the microprocessor systems used in automotive applications.

Furthermore the device is suitable also in other applications requiring two stabilized voltages.

The modular approach allows other features and functions to be realized easily when required.

STANDBY REGULATOR

The standby regulator uses an Isolated Collector Vertical PNP transistor as the regulating element. This structure allows a very low dropout voltage at currents up to 50mA. The dropout operation of the standby regulator is maintained down to 2V input supply voltage. The output voltage is regulated up to the transient input supply voltage of 40V. This feature avoids functional interruptions which could be generated by overvoltage pulses.

The typical curve of the standby output voltage as a function of the input supply voltage is shown in fig. 1.

The current consumption of the device (quiescent current) is less than 250 μA when output 2 is disabled (standby mode). The dropout voltage is controlled to reduce the quiescent current peak in the undervoltage region and to improve the transient response in this region.

The quiescent current is shown in fig. 2 as a function of the supply input voltage 2.

OUTPUT 2 VOLTAGE

The output 2 regulator uses the same output structure as the standby regulator, but rated for an output current of 500mA.

The output 2 regulator works in tracking mode with the standby output voltage as a reference voltage when the output 2 programming pin ADJ is connected to V_{O2} . By connecting a resistor divider R_1 , R_2 to the pin ADJ as shown in fig. 3, the output voltage 2 can be programmed to the value :

$$V_{O2} = V_{O1} (1 + R_1/R_2)$$

The output 2 regulator can be switched off via the Enable input.

If a fixed 5 regulation is required ADJ Pin has to be connected to V_{O2} Pin.



Figure 1 : Output Voltage vs. Input Voltage.

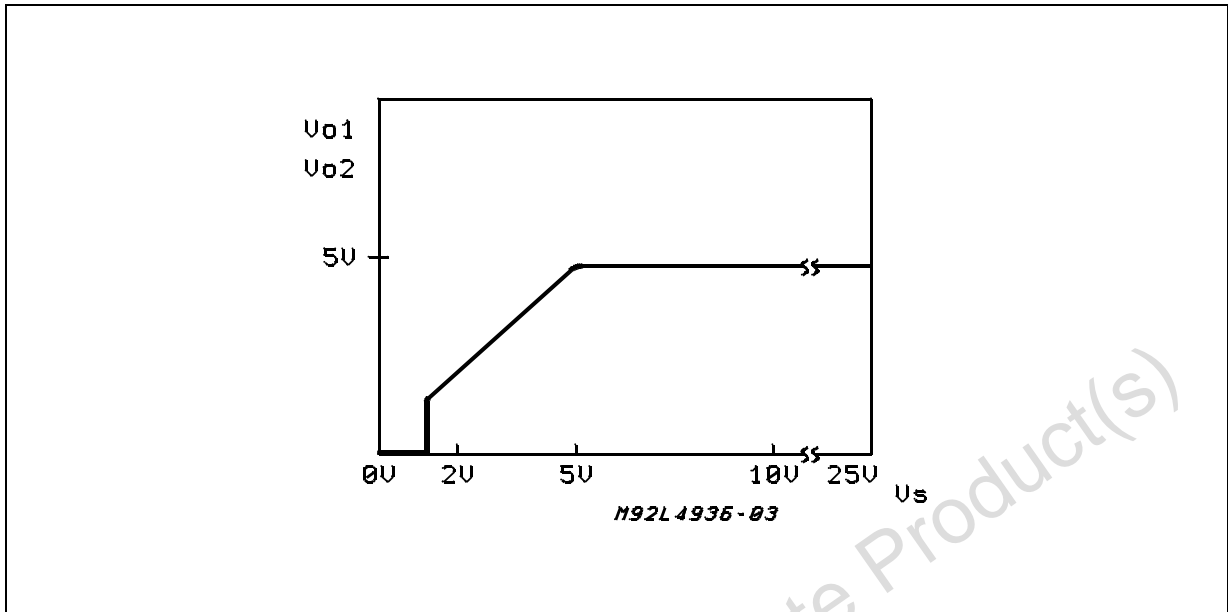

Figure 2 : Quiescent Current vs. Supply Voltage.

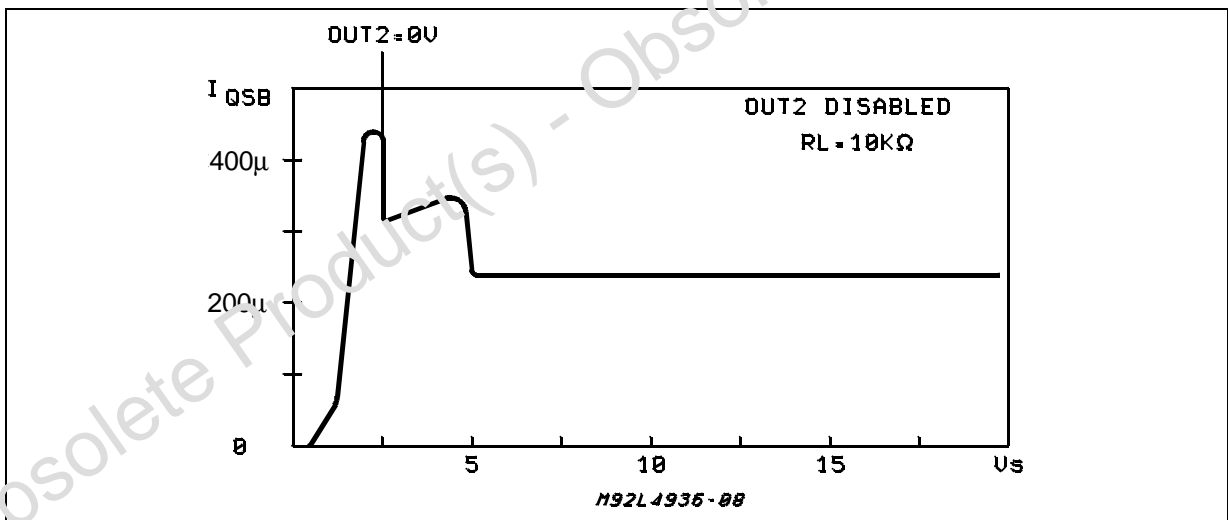
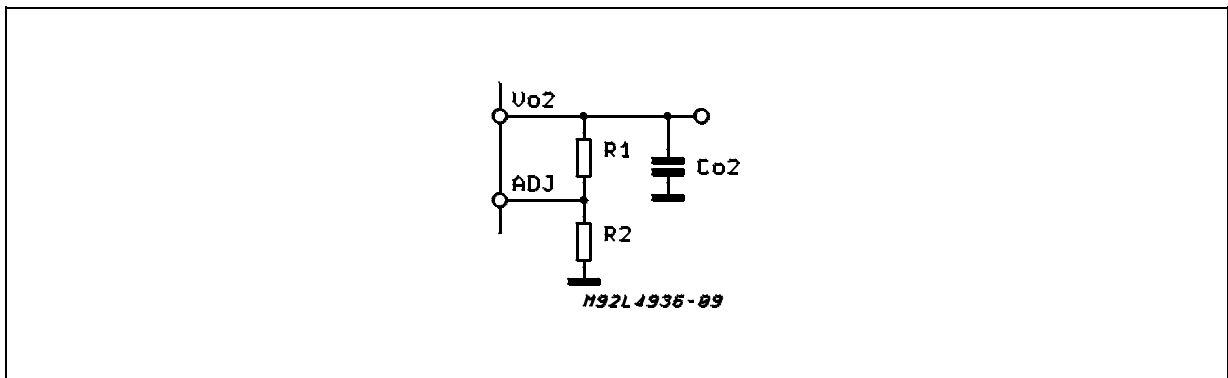

Figure 3 : Programmable Output 2 Voltage with External Resistors.



RESET CIRCUIT

The block circuit diagram of the reset circuit is shown in fig. 4. The reset circuit supervises the standby output voltage. The reset threshold of 4.7V is defined by the internal reference voltage and the standby output divider.

The reset pulse delay time t_{RD} , is defined by the charge time of an external capacitor C_T :

$$t_{RD} = \frac{C_T \times 2V}{2\mu A}$$

The reaction time of the reset circuit depends on the discharge time limitation of the reset capacitor C_T and is proportional to the value of C_T .

The reaction time of the reset circuit increases the noise immunity. In fact, if the standby output voltage drops below the reset threshold for a time shorter than the reaction time t_{RR} , no reset output variation

occurs. The nominal reset delay is generated for standby output voltage drops longer than the time necessary for the complete discharging of the capacitor C_T . This time is typically equal to 50 μ s if $C_T = 100$ nF. The typical reset output waveforms are shown in fig. 5.

SENSE COMPARATOR

This circuit compares an input signal with an internal voltage reference of typically 1.23V. The use of an external voltage divider makes the comparator very flexible in the application. This function can be used to supervise the input voltage - either before or after the protection diode - and to give additional information to the microprocessor such as low voltage warnings.

If this feature is not used SI and SO have to be connected to GND. In this case the standby quiescent current (14V) increases from 290 μ A to 300 μ A.

Figure 4: Block Diagram of the Reset Circuit.

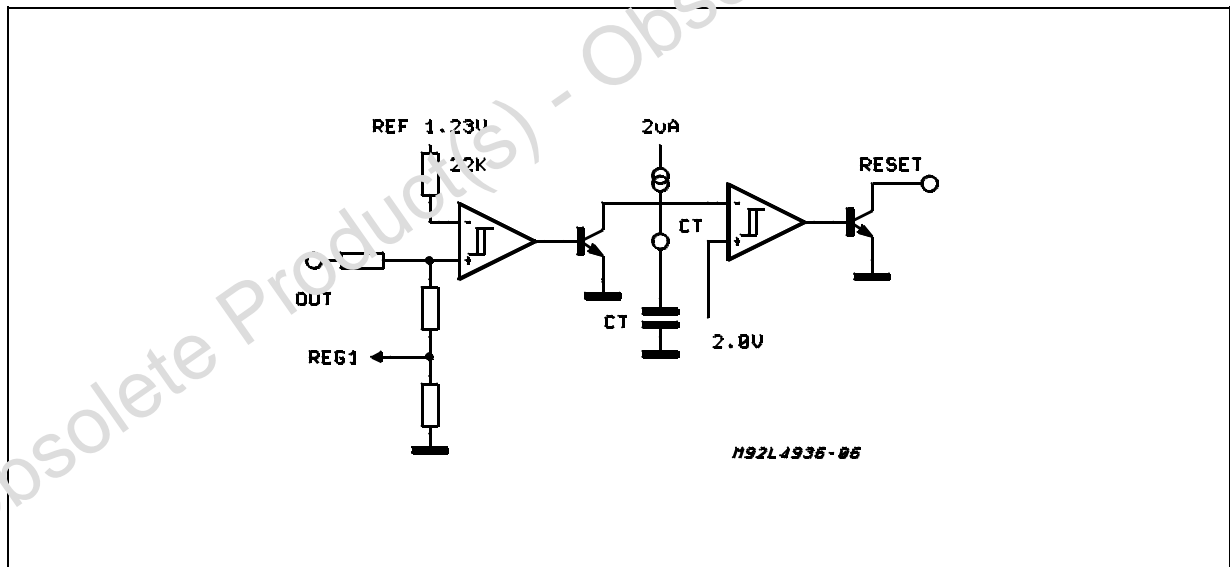
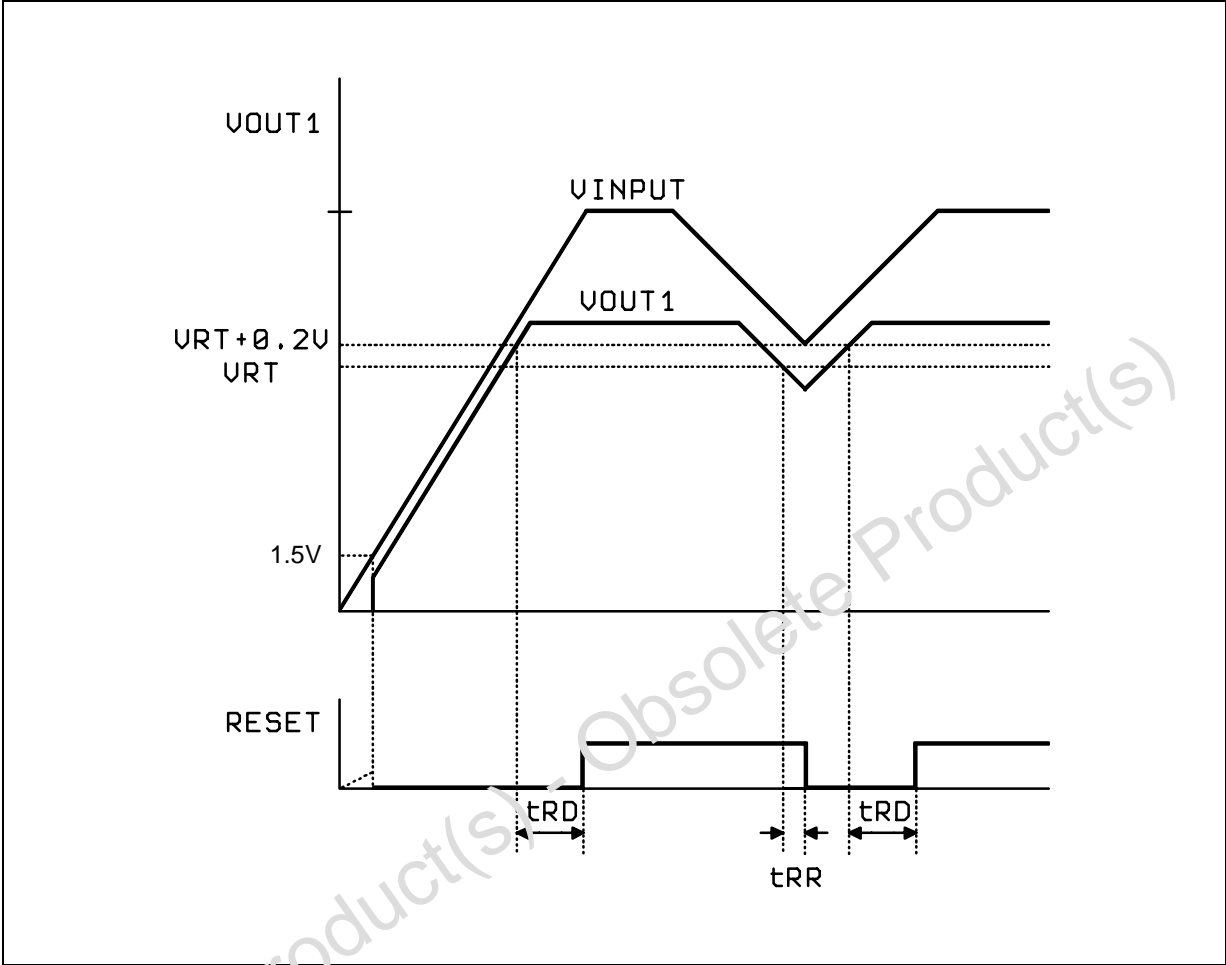
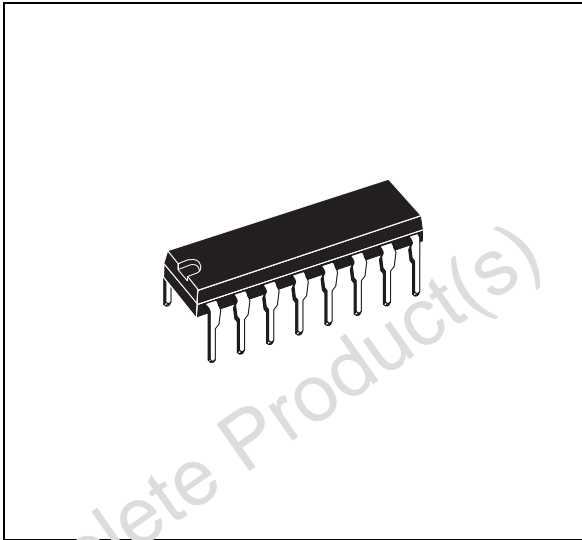

Figure 5 : Typical Reset Output Waveforms.



DIM.	mm			inch		
	MIN.	TYP.	MAX.	MIN.	TYP.	MAX.
a1	0.51			0.020		
B	0.85		1.40	0.033		0.055
b		0.50			0.020	
b1	0.38		0.50	0.015		0.020
D			20.0			0.787
E		8.80			0.346	
e		2.54			0.100	
e3		17.78			0.700	
F			7.10			0.280
I			5.10			0.201
L		3.30			0.130	
Z			1.27			0.050

OUTLINE AND MECHANICAL DATA



Powerdip 16

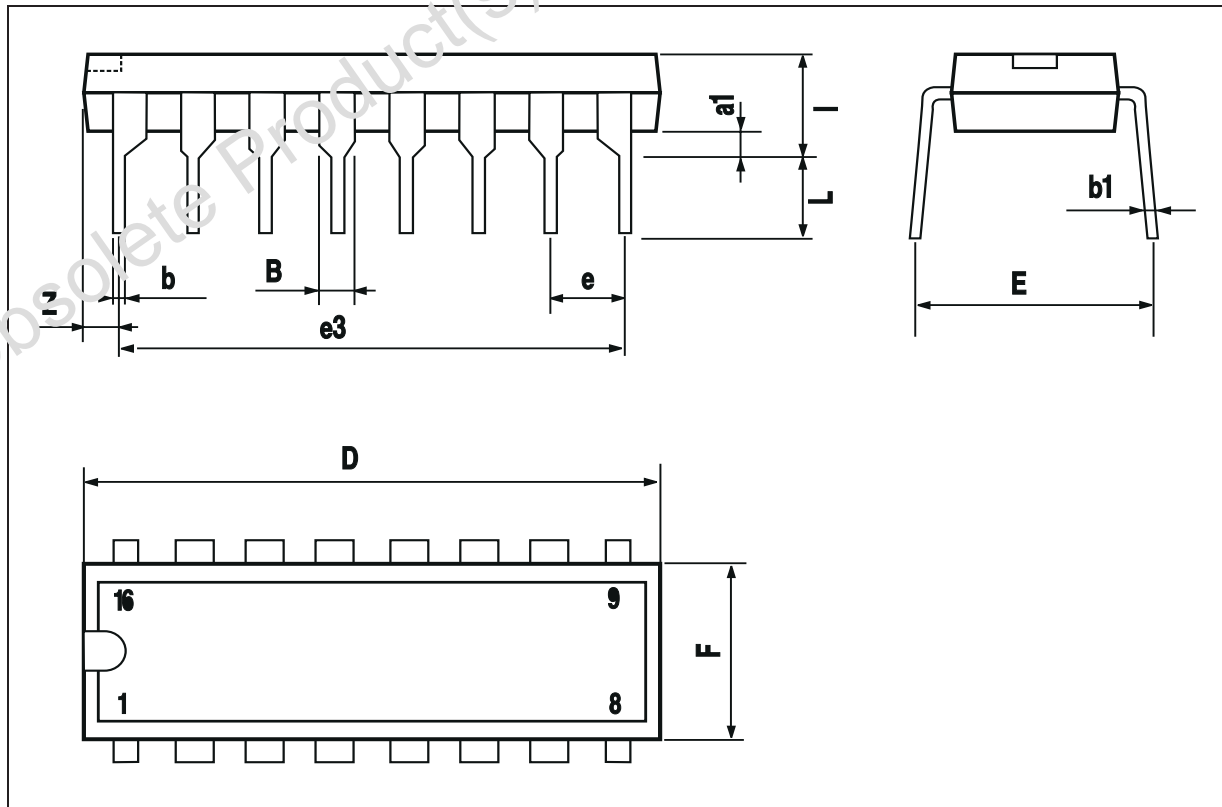

L4938N - L4938ND - L4938NPD

DIM.	mm			inch		
	MIN.	TYP.	MAX.	MIN.	TYP.	MAX.
A			3.6			0.142
a1	0.1		0.3	0.004		0.012
a2			3.3			0.130
a3	0		0.1	0.000		0.004
b	0.4		0.53	0.016		0.021
c	0.23		0.32	0.009		0.013
D (1)	15.8		16	0.622		0.630
D1	9.4		9.8	0.370		0.386
E	13.9		14.5	0.547		0.570
e		1.27			0.050	
e3		11.43			0.450	
E1 (1)	10.9		11.1	0.429		0.437
E2			2.9			0.114
E3	5.8		6.2	0.228		0.244
G	0		0.1	0.000		0.004
H	15.5		15.9	0.610		0.626
h			1.1			0.043
L	0.8		1.1	0.031		0.043
N	10° (max.)					
S	8° (max.)					
T		10			0.394	

(1) "D and F" do not include mold flash or protrusions.
 - Mold flash or protrusions shall not exceed 0.15 mm (0.006").
 - Critical dimensions: "E", "G" and "a3"

OUTLINE AND MECHANICAL DATA

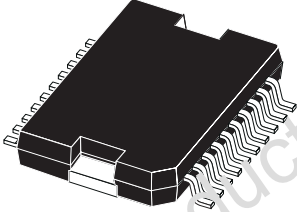

JEDEC MO-166

PowerSO20

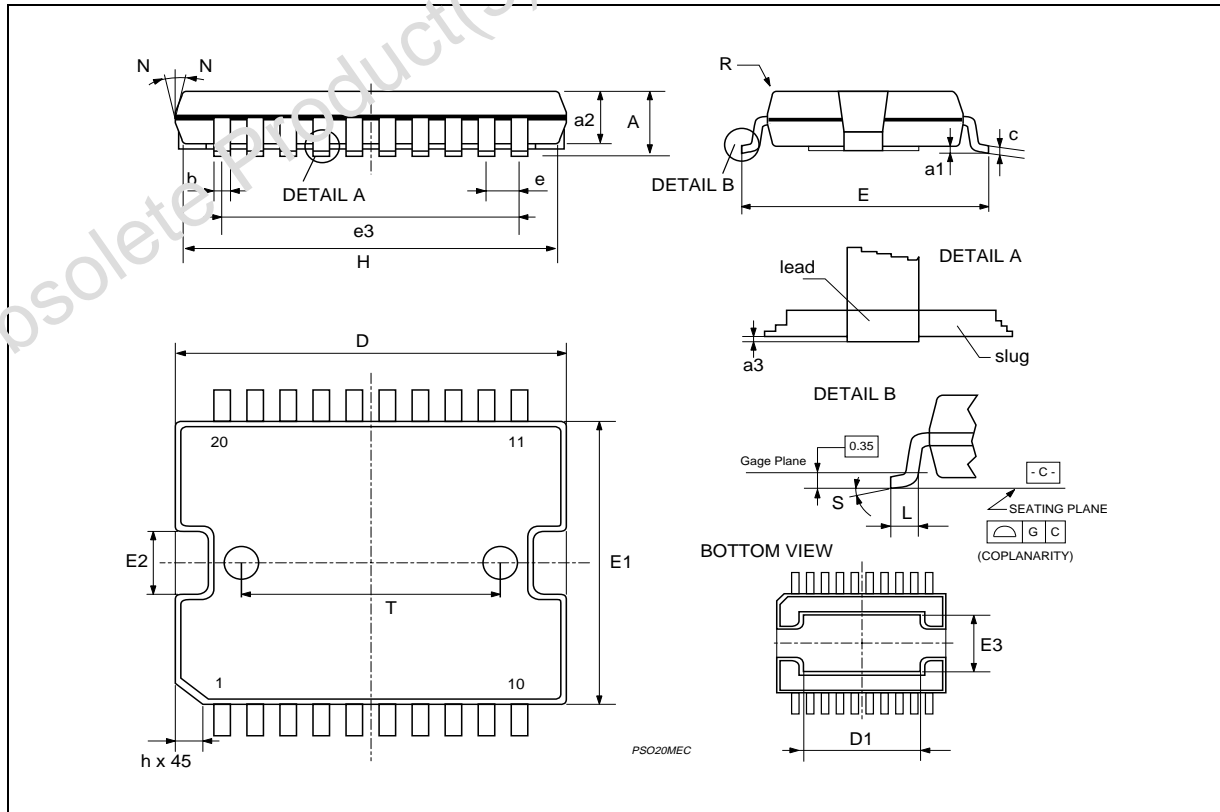

DIM.	mm			inch		
	MIN.	TYP.	MAX.	MIN.	TYP.	MAX.
A	2.35		2.65	0.093		0.104
A1	0.1		0.3	0.004		0.012
B	0.33		0.51	0.013		0.020
C	0.23		0.32	0.009		0.013
D	12.6		13	0.496		0.512
E	7.4		7.6	0.291		0.299
e		1.27			0.050	
H	10		10.65	0.394		0.419
h	0.25		0.75	0.010		0.030
L	0.4		1.27	0.016		0.050
K	0° (min.)8° (max.)					

OUTLINE AND MECHANICAL DATA

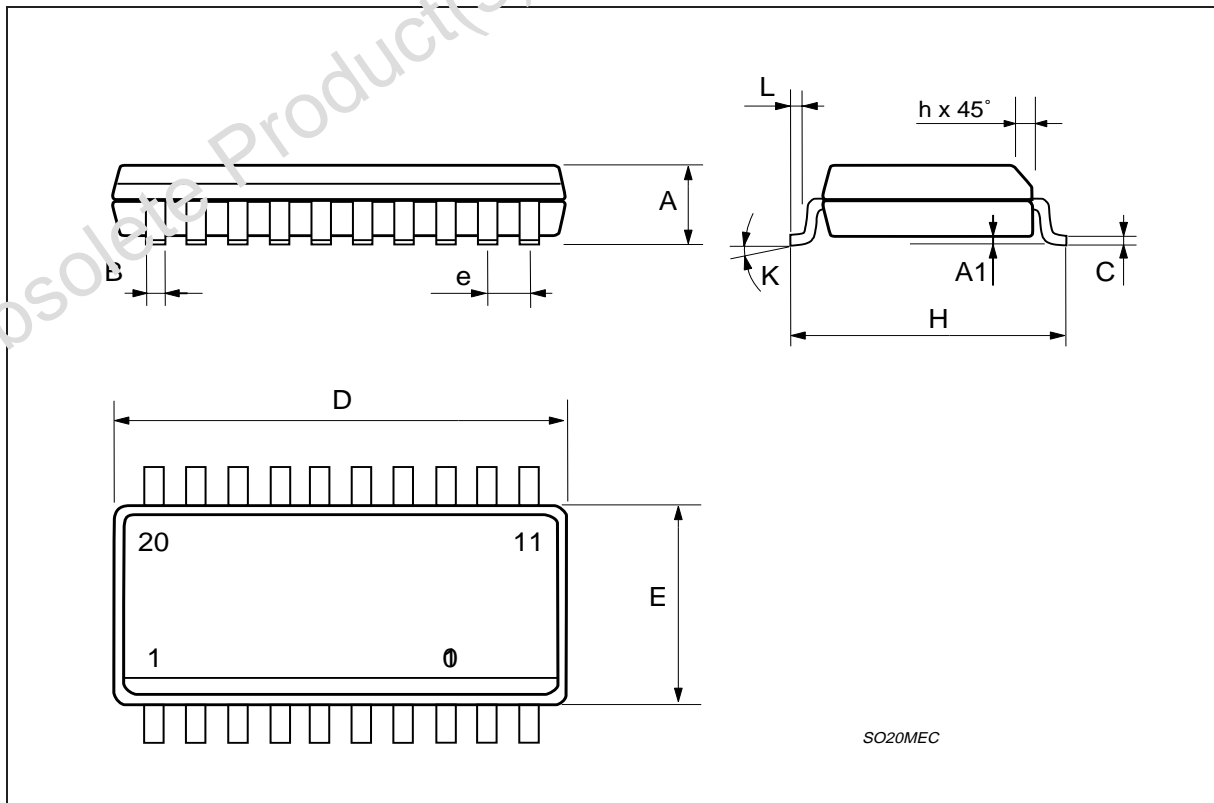
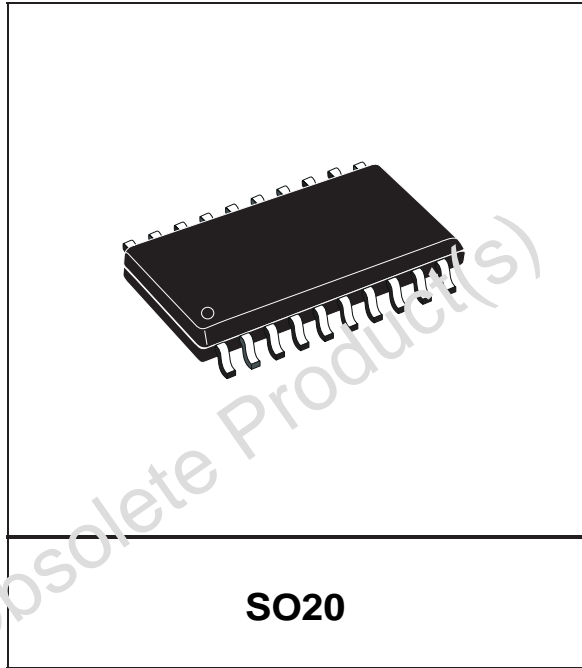

Obsolete Product(s) - Obsolete Product(s)

Information furnished is believed to be accurate and reliable. However, STMicroelectronics assumes no responsibility for the consequences of use of such information nor for any infringement of patents or other rights of third parties which may result from its use. No license is granted by implication or otherwise under any patent or patent rights of STMicroelectronics. Specification mentioned in this publication are subject to change without notice. This publication supersedes and replaces all information previously supplied. STMicroelectronics products are not authorized for use as critical components in life support devices or systems without express written approval of STMicroelectronics.

The ST logo is a registered trademark of STMicroelectronics
© 1999 STMicroelectronics – Printed in Italy – All Rights Reserved
STMicroelectronics GROUP OF COMPANIES

Australia - Brazil - Canada - China - France - Germany - Italy - Japan - Korea - Malaysia - Malta - Mexico - Morocco - The Netherlands - Singapore - Spain - Sweden - Switzerland - Taiwan - Thailand - United Kingdom - U.S.A.

<http://www.st.com>