

**F861 Series Metallized Polypropylene Film, Class X2, 310 VAC****KEMET**  
CHARGED®**Overview**

The F861 Series is constructed of metallized polypropylene film encapsulated with self-extinguishing resin in a box of material meeting the requirements of UL 94 V-0.

**Applications**

For worldwide use as electromagnetic interference (EMI) suppression filter in across-the-line applications requiring X2 safety classification. Not for use in "series with mains" type applications.

**Benefits**

- Approvals: ENEC, UL, cUL, CQC
- Rated voltage: 310 VAC 50/60 Hz
- Capacitance range: 0.001 – 45  $\mu$ F
- Lead spacing: 7.5 – 52.5 mm
- Capacitance tolerance:  $\pm 20\%$ ,  $\pm 10\%$
- Climatic category: 40/110/56, IEC 60068-1
- Tape and reel in accordance with IEC 60286-2
- RoHS Compliant and lead-free terminations
- Operating temperature range of  $-40^{\circ}\text{C}$  to  $+110^{\circ}\text{C}$
- 100% screening factory test at 1,900 VDC

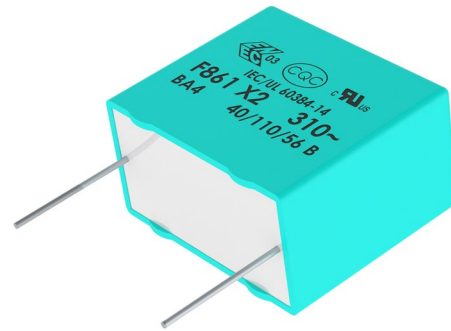
**Part Number System**

F	861	B	C	104	M	310	C
Capacitor Class	Series	Lead Spacing (mm)	Size Code	Capacitance Code (pF)	Capacitance Tolerance	Voltage (VAC)	Lead and Packaging Code
F = Film	X2, Metallized Polypropylene	K = 7.5 A = 10 B = 15 D = 22.5 F = 27.5 R = 37.5 G = 52.5	See Dimension Table	First two digits represent significant figures. Third digit specifies number of zeros.	K = $\pm 10\%$ M = $\pm 20\%$	310	See Ordering Options Table

**Ordering Options Table**

Lead Spacing Nominal (mm)	Type of Leads and Packaging	Lead Length (mm)	Lead and Packaging Code
7.5	<b>Standard Lead and Packaging Options</b>		
	Bulk (Bag) – Short Leads	4 +2/-0	C
	Bulk (Bag) – Long Leads	17 +0/-1	A
	Tape & Reel (Standard Reel)	$H_0 = 18.5 \pm 0.5$	L
	<b>Other Lead and Packaging Options</b>		
	Bulk (Bag) – Max Length Leads	20 +5/-0	ALL0L
	Ammo Pack	$H_0 = 18.5 \pm 0.5$	R

## Ordering Options Table cont'd

Lead Spacing Nominal (mm)	Type of Leads and Packaging	Lead Length (mm)	Lead and Packaging Code
10	<b>Standard Lead and Packaging Options</b>		
	Bulk (Bag) – Short Leads	4 +2/-0	C
	Bulk (Bag) – Long Leads	17 +0/-1	A
	Tape & Reel (Standard Reel)	$H_0 = 18.5 \pm 0.5$	L
	<b>Other Lead and Packaging Options</b>		
	Bulk (Bag) – Max Length Leads	20 +5/-0	ALLOL
	Ammo Pack	$H_0 = 18.5 \pm 0.5$	R
	Tape & Reel (Large Reel)	$H_0 = 18.5 \pm 0.5$	P
15	<b>Standard Lead and Packaging Options</b>		
	Bulk (Bag) – Short Leads	4 +2/-0	C
	Bulk (Bag) – Long Leads	17 +0/-1	A
	Tape & Reel (Standard Reel)	$H_0 = 18.5 \pm 0.5$	L
	Pizza Pack	4 +2/-0	Z
	<b>Other Lead and Packaging Options</b>		
	Bulk (Bag) – Max Length Leads	25 +5/-0	ALROL
	Ammo Pack	$H_0 = 18.5 \pm 0.5$	R
	Tape & Reel (Large Reel)	$H_0 = 18.5 \pm 0.5$	P
22.5	<b>Standard Lead and Packaging Options</b>		
	Pizza – Long Leads	17 +0/-1	ZLH0J
	Pizza Pack	4 +2/-0	Z
	<b>Other Lead and Packaging Options</b>		
	Tape & Reel (Standard Reel)	$H_0 = 18.5 \pm 0.5$	L
	Tape & Reel (Large Reel)	$H_0 = 18.5 \pm 0.5$	P
	Ammo Pack	$H_0 = 18.5 \pm 0.5$	R
27.5	<b>Standard Lead and Packaging Options</b>		
	Pizza – Long Leads	17 +0/-1	ZLH0J
	Pizza Pack	4 +2/-0	Z
37.5	<b>Standard Lead and Packaging Options</b>		
	Pizza – Long Leads	17 +0/-1	ZLH0J
	Pizza Pack	4 +2/-0	Z
52.5	<b>Standard Lead and Packaging Options</b>		
	Bulk (Tray) – 4 Lead	4 +2/-0	H
	Pizza Pack – 4 Lead	4 +2/-0	Z

## Dimensions – Millimeters

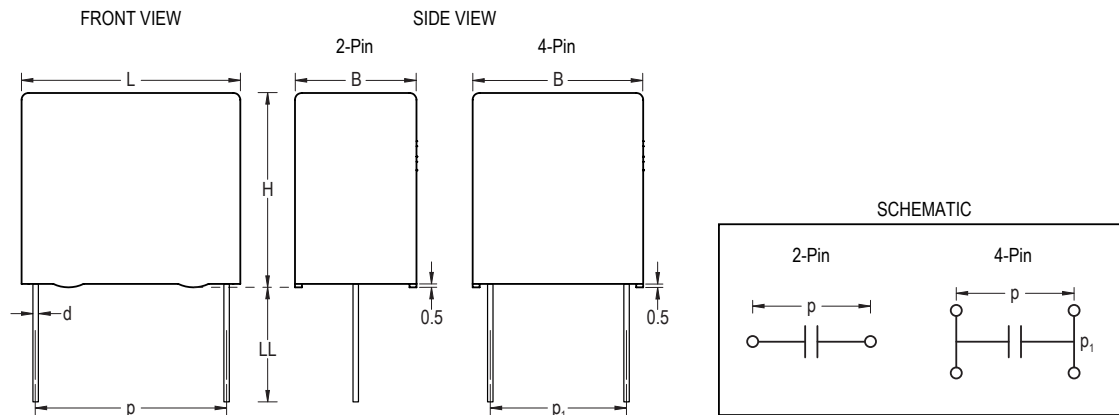

Size Code	Version	p		p <sup>1</sup>		B		H		L		d	
		Nominal	Tolerance	Nominal	Tolerance	Nominal	Tolerance	Nominal	Tolerance	Nominal	Tolerance	Nominal	Tolerance
KF		7.5	+/-0.4			3	Maximum	8	Maximum	10	Maximum	0.6	+/-0.05
KG		7.5	+/-0.4			4	Maximum	8	Maximum	10	Maximum	0.6	+/-0.05
KH		7.5	+/-0.4			4	Maximum	9	Maximum	10	Maximum	0.6	+/-0.05
KJ		7.5	+/-0.4			5	Maximum	10.5	Maximum	10	Maximum	0.6	+/-0.05
KM		7.5	+/-0.4			6	Maximum	12	Maximum	10.5	Maximum	0.6	+/-0.05
AG		10.0	+/-0.4			4.0	Maximum	9.0	Maximum	13.0	Maximum	0.6	+/-0.05
AK		10.0	+/-0.4			5.0	Maximum	11.0	Maximum	13.0	Maximum	0.6	+/-0.05
AP		10.0	+/-0.4			6.0	Maximum	12.0	Maximum	13.0	Maximum	0.6	+/-0.05
AO		10.0	+/-0.4			7.0	Maximum	17.0	Maximum	13.0	Maximum	0.6	+/-0.05
AL	Low Profile	10.0	+/-0.4			9.5	Maximum	7.5	Maximum	13.0	Maximum	0.6	+/-0.05
AE	Special Version	10.0	+/-0.4			4.0	Maximum	8.0	Maximum	13.0	Maximum	0.6	+/-0.05
BB		15.0	+/-0.4			4.0	Maximum	10.0	Maximum	18.0	Maximum	0.8	+/-0.05
BC		15.0	+/-0.4			5.0	Maximum	11.0	Maximum	18.0	Maximum	0.8	+/-0.05
BE		15.0	+/-0.4			5.5	Maximum	12.5	Maximum	18.0	Maximum	0.8	+/-0.05
BG		15.0	+/-0.4			6.0	Maximum	12.0	Maximum	18.0	Maximum	0.8	+/-0.05
BI	High Profile	15.0	+/-0.4			6.0	Maximum	17.5	Maximum	18.0	Maximum	0.8	+/-0.05
BK		15.0	+/-0.4			7.5	Maximum	13.5	Maximum	18.0	Maximum	0.8	+/-0.05
BO	High Profile	15.0	+/-0.4			7.5	Maximum	18.5	Maximum	18.0	Maximum	0.8	+/-0.05
BP		15.0	+/-0.4			8.5	Maximum	14.5	Maximum	18.0	Maximum	0.8	+/-0.05
BT		15.0	+/-0.4			9.0	Maximum	12.5	Maximum	18.0	Maximum	0.8	+/-0.05
BS		15.0	+/-0.4			10.0	Maximum	16.0	Maximum	18.0	Maximum	0.8	+/-0.05
BY		15.0	+/-0.4			11.0	Maximum	19.0	Maximum	18.0	Maximum	0.8	+/-0.05
BZ	Special Version	15.0	+/-0.4			12.0	Maximum	20.0	Maximum	18.0	Maximum	0.8	+/-0.05
BR	Low Profile	15.0	+/-0.4			13.0	Maximum	12.0	Maximum	18.0	Maximum	0.8	+/-0.05
DB		22.5	+/-0.4			6.0	Maximum	14.5	Maximum	26.0	Maximum	0.8	+/-0.05
DI		22.5	+/-0.4			7.0	Maximum	16.0	Maximum	26.0	Maximum	0.8	+/-0.05
DH		22.5	+/-0.4			8.0	Maximum	16.0	Maximum	26.0	Maximum	0.8	+/-0.05
DJ		22.5	+/-0.4			8.5	Maximum	17.0	Maximum	26.0	Maximum	0.8	+/-0.05
DM		22.5	+/-0.4			9.0	Maximum	18.5	Maximum	26.0	Maximum	0.8	+/-0.05
DO		22.5	+/-0.4			10.0	Maximum	18.5	Maximum	26.0	Maximum	0.8	+/-0.05

Note: See Ordering Options Table for lead length (LL) options.

## Dimensions – Millimeters cont'd

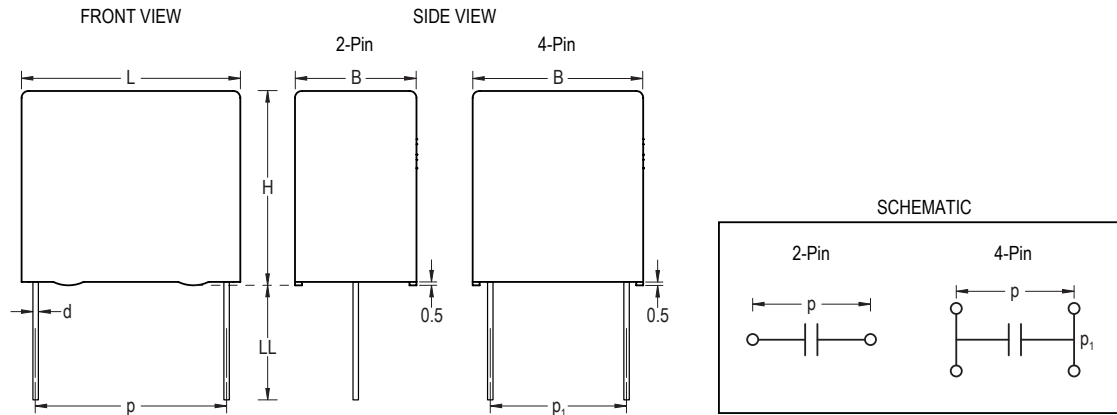

Size Code	Version	p		p <sup>1</sup>		B		H		L		d	
		Nominal	Tolerance	Nominal	Tolerance	Nominal	Tolerance	Nominal	Tolerance	Nominal	Tolerance	Nominal	Tolerance
DP		22.5	+/-0.4			11.0	Maximum	20.0	Maximum	26.0	Maximum	0.8	+/-0.05
DU		22.5	+/-0.4			13.0	Maximum	22.0	Maximum	26.0	Maximum	0.8	+/-0.05
DY		22.5	+/-0.4			15.5	Maximum	24.5	Maximum	26.0	Maximum	0.8	+/-0.05
FB		27.5	+/-0.4			9.0	Maximum	17.0	Maximum	31.5	Maximum	0.8	+/-0.05
FC		27.5	+/-0.4			11.0	Maximum	20.0	Maximum	31.5	Maximum	0.8	+/-0.05
FI		27.5	+/-0.4			13.0	Maximum	25.0	Maximum	31.5	Maximum	0.8	+/-0.05
FN		27.5	+/-0.4			14.0	Maximum	28.0	Maximum	31.5	Maximum	0.8	+/-0.05
FO	High Profile	27.5	+/-0.4			17.0	Maximum	40.0	Maximum	31.5	Maximum	0.8	+/-0.05
FR		27.5	+/-0.4			17.5	Maximum	28.0	Maximum	31.5	Maximum	0.8	+/-0.05
FS		27.5	+/-0.4			19.0	Maximum	29.0	Maximum	31.5	Maximum	0.8	+/-0.05
FY		27.5	+/-0.4			22.0	Maximum	37.0	Maximum	31.5	Maximum	0.8	+/-0.05
FH	Low Profile	27.5	+/-0.4			21.0	Maximum	12.5	Maximum	31.5	Maximum	0.8	+/-0.05
FQ	Low Profile	27.5	+/-0.4			27.5	Maximum	16.0	Maximum	31.5	Maximum	0.8	+/-0.05
FT	Low Profile	27.5	+/-0.4			31.0	Maximum	19.0	Maximum	31.5	Maximum	0.8	+/-0.05
RB		37.5	+/-0.4			11.0	Maximum	22.0	Maximum	41.0	Maximum	1	+/-0.05
RF		37.5	+/-0.4			13.0	Maximum	24.0	Maximum	41.0	Maximum	1	+/-0.05
RH		37.5	+/-0.4			15.0	Maximum	26.0	Maximum	41.0	Maximum	1	+/-0.05
RC		37.5	+/-0.4			16.0	Maximum	28.5	Maximum	41.0	Maximum	1	+/-0.05
RD		37.5	+/-0.4			19.0	Maximum	32.0	Maximum	41.0	Maximum	1	+/-0.05
RP		37.5	+/-0.4			21.0	Maximum	38.0	Maximum	41.0	Maximum	1	+/-0.05
RO		37.5	+/-0.4			24.0	Maximum	44.0	Maximum	41.0	Maximum	1	+/-0.05
RU		37.5	+/-0.4			30.0	Maximum	45.0	Maximum	41.0	Maximum	1	+/-0.05
RV	Low Profile	37.5	+/-0.4			24.0	Maximum	15.0	Maximum	41.0	Maximum	1	+/-0.05
RW	Low Profile	37.5	+/-0.4			24.0	Maximum	19.0	Maximum	41.0	Maximum	1	+/-0.05
GD		52.5	+/-0.4	20.3	+/-0.4	30.0	Maximum	45.0	Maximum	57.5	Maximum	1	+/-0.05
GE		52.5	+/-0.4	20.3	+/-0.4	35.0	Maximum	50.0	Maximum	57.5	Maximum	1	+/-0.05

**Note: See Ordering Options Table for lead length (LL) options.**

## Performance Characteristics

Rated Voltage	310 VAC 50/60 Hz		
Capacitance Range	0.001 – 45 $\mu$ F		
Capacitance Tolerance	$\pm$ 20%, $\pm$ 10%		
Temperature Range	-40°C to +110°C		
Climatic Category	40/110/56		
Approvals	ENEC, UL, cUL, CQC		
Dissipation Factor	Maximum Values at +23°C		
		$C \leq 0.1 \mu$ F	$C > 0.1 \mu$ F
	1 kHz	0.3%	0.2%
Test Voltage Between Terminals	The 100% screening factory test is carried out at 1,900 VDC. The voltage level is selected to meet the requirements in applicable equipment standards. All electrical characteristics are checked after the test. It is not permitted to repeat this test as there is a risk to damage the capacitor. KEMET is not liable in such case for any failures.		
Insulation Resistance	Minimum Values Between Terminals		
	$C \leq 0.33 \mu$ F	$\geq 30,000 \text{ M}\Omega$	
	$C > 0.33 \mu$ F	$\geq 10,000 \text{ M}\Omega \cdot \mu$ F	
In DC Applications	Recommended voltage $\leq 630$ VDC		

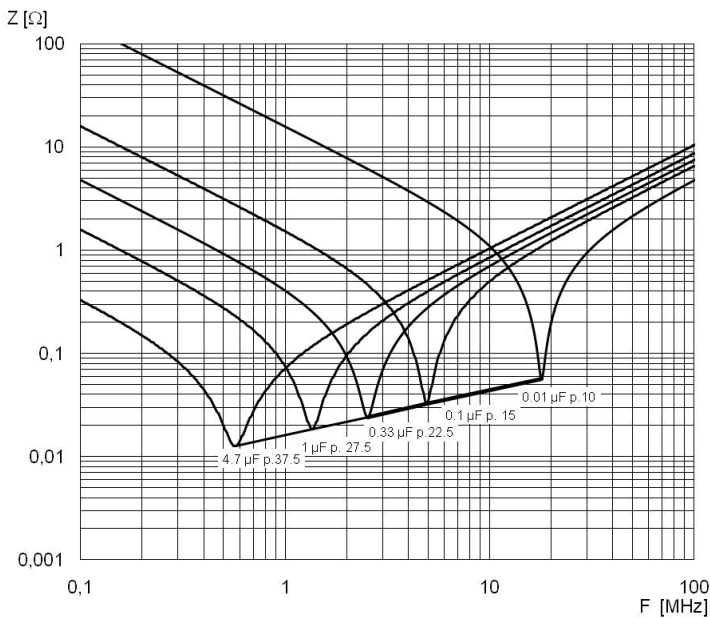

## Impedance Graph



## Environmental Test Data

Test	IEC Publication	Procedure
Endurance	IEC 60384-14	1.25 x V <sub>R</sub> VAC 50 Hz, once every hour increase to 1,000 VAC for 0.1 second, 1,000 hours at upper rated temperature
Vibration	IEC 60068-2-6 Test Fc	3 directions at 2 hours each 10 – 55 Hz at 0.75 mm or 98 m/s <sup>2</sup>
Bump	IEC 60068-2-29 Test Eb	1,000 bumps at 390 m/s <sup>2</sup>
Change of Temperature	IEC 60068-2-14 Test Na	Upper and lower rated temperature 5 cycles
Active Flammability	IEC 60384-14	V <sub>R</sub> + 20 surge pulses at 2.5 kV (pulse every 5 seconds)
Passive Flammability	IEC 60384-14	IEC 60384-1, IEC 60695-11-5 Needle-flame test
Damp Heat Steady State	IEC 60068-2-78 Test Cab	+40°C and 93% RH, 56 days

## Approvals

Mark	Specification	File Number
	EN/IEC 60384-14	CA08.00189
	UL 60384-14 and CAN/CSA-E60384-14	E97797
	IEC 60384-14	CQC12001084206 CQC12001084386 CQC12001084203 CQC12001084205 CQC12001084204 CQC12001084195 CQC12001084207

## Environmental Compliance

All new KEMET EMI capacitors are RoHS Compliant and Halogen Free.



RoHS Compliant



**Table 1 – Ratings & Part Number Reference**

Capacitance Value (µF)	Size Code	Maximum Dimensions in mm			Lead Spacing (p)	dV/dt (V/µs)	Part Number
		B	H	L			
0.001	KF	3	8	10	7.5	500	F861KF102(1)310(2)
0.0012	KF	3	8	10	7.5	500	F861KF122(1)310(2)
0.0015	KF	3	8	10	7.5	500	F861KF152(1)310(2)
0.0018	KF	3	8	10	7.5	500	F861KF182(1)310(2)
0.0022	KF	3	8	10	7.5	500	F861KF222(1)310(2)
0.0025	KF	3	8	10	7.5	500	F861KF252(1)310(2)
0.0027	KF	3	8	10	7.5	500	F861KF272(1)310(2)
0.0033	KF	3	8	10	7.5	500	F861KF332(1)310(2)
0.0039	KF	3	8	10	7.5	500	F861KF392(1)310(2)
0.0047	KF	3	8	10	7.5	500	F861KF472(1)310(2)
0.0056	KF	3	8	10	7.5	500	F861KF562(1)310(2)
0.0068	KF	3	8	10	7.5	500	F861KF682(1)310(2)
0.0082	KF	3	8	10	7.5	500	F861KF822(1)310(2)
0.01	KG	4	8	10	7.5	500	F861KG103(1)310(2)
0.012	KG	4	8	10	7.5	500	F861KG123(1)310(2)
0.015	KH	4	9	10	7.5	500	F861KH153(3)310(2)
0.018	KJ	5	10.5	10	7.5	500	F861KJ183(1)310(2)
0.022	KJ	5	10.5	10	7.5	500	F861KJ223(1)310(2)
0.025	KJ	5	10.5	10	7.5	500	F861KJ253(1)310(2)
0.027	KJ	5	10.5	10	7.5	500	F861KJ273(1)310(2)
0.033	KJ	5	10.5	10	7.5	500	F861KJ333(3)310(2)
0.033	KM	6	12	10.5	7.5	500	F861KM333(1)310(2)
0.039	KM	6	12	10.5	7.5	500	F861KM393(1)310(2)
0.047	KM	6	12	10.5	7.5	500	F861KM473(3)310(2)
0.001	AE	4	8	13	10	500	F861AE102(1)310(2)
0.0012	AE	4	8	13	10	500	F861AE122(1)310(2)
0.0015	AE	4	8	13	10	500	F861AE152(1)310(2)
0.0018	AE	4	8	13	10	500	F861AE182(1)310(2)
0.0018	AL	9.5	7.5	13	10	500	F861AL182(1)310(2)
0.0022	AE	4	8	13	10	500	F861AE222(1)310(2)
0.0022	AL	9.5	7.5	13	10	500	F861AL222(1)310(2)
0.0025	AE	4	8	13	10	500	F861AE252(1)310(2)
0.0025	AL	9.5	7.5	13	10	500	F861AL252(1)310(2)
0.0027	AE	4	8	13	10	500	F861AE272(1)310(2)
0.0027	AL	9.5	7.5	13	10	500	F861AL272(1)310(2)
0.0033	AE	4	8	13	10	500	F861AE332(1)310(2)
0.0033	AL	9.5	7.5	13	10	500	F861AL332(1)310(2)
0.0039	AE	4	8	13	10	500	F861AE392(1)310(2)
0.0039	AL	9.5	7.5	13	10	500	F861AL392(1)310(2)
0.0047	AE	4	8	13	10	500	F861AE472(1)310(2)
0.0047	AL	9.5	7.5	13	10	500	F861AL472(1)310(2)
0.0056	AE	4	8	13	10	500	F861AE562(1)310(2)
0.0056	AL	9.5	7.5	13	10	500	F861AL562(1)310(2)
0.0068	AE	4	8	13	10	500	F861AE682(1)310(2)
0.0068	AL	9.5	7.5	13	10	500	F861AL682(1)310(2)
0.0082	AE	4	8	13	10	500	F861AE822(1)310(2)
0.0082	AL	9.5	7.5	13	10	500	F861AL822(1)310(2)
0.01	AE	4	8	13	10	500	F861AE103(1)310(2)
0.01	AL	9.5	7.5	13	10	500	F861AL103(1)310(2)
0.012	AE	4	8	13	10	500	F861AE123(1)310(2)
0.015	AE	4	8	13	10	500	F861AE153(1)310(2)
0.015	AL	9.5	7.5	13	10	500	F861AL153(1)310(2)
0.018	AE	4	8	13	10	500	F861AE183(1)310(2)
0.018	AL	9.5	7.5	13	10	500	F861AL183(1)310(2)
0.022	AE	4	8	13	10	500	F861AE223(1)310(2)
0.022	AL	9.5	7.5	13	10	500	F861AL223(1)310(2)
0.025	AE	4	8	13	10	500	F861AE253(1)310(2)
0.025	AL	9.5	7.5	13	10	500	F861AL253(1)310(2)
0.027	AE	4	8	13	10	500	F861AE273(1)310(2)
Capacitance Value (µF)	Size Code	B (mm)	H (mm)	L (mm)	Lead Spacing (p)	dV/dt (V/µs)	Part Number

(1) M = ±20%, K = ±10%.

(2) Insert lead and packaging code. See Ordering Options Table for available options.

(3) M = ±20% (only available tolerance).

**Table 1 – Ratings & Part Number Reference cont'd**

Capacitance Value (µF)	Size Code	Maximum Dimensions in mm			Lead Spacing (p)	dV/dt (V/µs)	Part Number
		B	H	L			
0.027	AL	9.5	7.5	13	10	500	F861AL273(1)310(2)
0.033	AE	4	8	13	10	500	F861AE333(1)310(2)
0.033	AL	9.5	7.5	13	10	500	F861AL333(1)310(2)
0.039	AE	4	8	13	10	500	F861AE393(1)310(2)
0.039	AL	9.5	7.5	13	10	500	F861AL393(1)310(2)
0.047	AE	4	8	13	10	500	F861AE473(3)310(2)
0.047	AL	9.5	7.5	13	10	500	F861AL473(1)310(2)
0.056	AG	4	9	13	10	500	F861AG563(1)310(2)
0.056	AL	9.5	7.5	13	10	500	F861AL563(1)310(2)
0.068	AK	5	11	13	10	500	F861AK683(1)310(2)
0.068	AL	9.5	7.5	13	10	500	F861AL683(1)310(2)
0.082	AK	5	11	13	10	500	F861AK823(1)310(2)
0.082	AL	9.5	7.5	13	10	500	F861AL823(1)310(2)
0.1	AK	5	11	13	10	500	F861AK104(3)310(2)
0.1	AL	9.5	7.5	13	10	500	F861AL104(1)310(2)
0.1	AP	6	12	13	10	500	F861AP104(1)310(2)
0.12	AL	9.5	7.5	13	10	500	F861AL124(1)310(2)
0.12	AP	6	12	13	10	500	F861AP124(1)310(2)
0.15	AO	7	17	13	10	500	F861AO154(1)310(2)
0.15	AP	6	12	13	10	500	F861AP154(3)310(2)
0.18	AO	7	17	13	10	500	F861AO184(1)310(2)
0.22	AO	7	17	13	10	500	F861AO224(1)310(2)
0.25	AO	7	17	13	10	500	F861AO254(1)310(2)
0.27	AO	7	17	13	10	500	F861AO274(1)310(2)
0.0027	BB	4	10	18	15	400	F861BB272(1)310(2)
0.0033	BB	4	10	18	15	400	F861BB332(1)310(2)
0.0039	BB	4	10	18	15	400	F861BB392(1)310(2)
0.0047	BB	4	10	18	15	400	F861BB472(1)310(2)
0.0056	BB	4	10	18	15	400	F861BB562(1)310(2)
0.0068	BB	4	10	18	15	400	F861BB682(1)310(2)
0.0082	BB	4	10	18	15	400	F861BB822(1)310(2)
0.01	BB	4	10	18	15	400	F861BB103(1)310(2)
0.012	BB	4	10	18	15	400	F861BB123(1)310(2)
0.015	BB	4	10	18	15	400	F861BB153(1)310(2)
0.018	BB	4	10	18	15	400	F861BB183(1)310(2)
0.022	BB	4	10	18	15	400	F861BB223(1)310(2)
0.025	BB	4	10	18	15	400	F861BB253(1)310(2)
0.027	BB	4	10	18	15	400	F861BB273(1)310(2)
0.033	BB	4	10	18	15	400	F861BB333(1)310(2)
0.039	BB	4	10	18	15	400	F861BB393(1)310(2)
0.047	BB	4	10	18	15	400	F861BB473(1)310(2)
0.056	BB	4	10	18	15	400	F861BB563(1)310(2)
0.068	BB	4	10	18	15	400	F861BB683(1)310(2)
0.082	BB	4	10	18	15	400	F861BB823(1)310(2)
0.1	BB	4	10	18	15	400	F861BB104(1)310(2)
0.12	BB	4	10	18	15	400	F861BB124(3)310(2)
0.12	BC	5	11	18	15	400	F861BC124(1)310(2)
0.15	BC	5	11	18	15	400	F861BC154(1)310(2)
0.15	BT	9	12.5	18	15	400	F861BT154(1)310(2)
0.18	BC	5	11	18	15	400	F861BC184(3)310(2)
0.18	BE	5.5	12.5	18	15	400	F861BE184(1)310(2)
0.18	BT	9	12.5	18	15	400	F861BT184(1)310(2)
0.22	BE	5.5	12.5	18	15	400	F861BE224(1)310(2)
0.22	BG	6	12	18	15	400	F861BG224(1)310(2)
0.22	BT	9	12.5	18	15	400	F861BT224(1)310(2)
0.25	BG	6	12	18	15	400	F861BG254(1)310(2)
0.25	BT	9	12.5	18	15	400	F861BT254(1)310(2)
0.27	BG	6	12	18	15	400	F861BG274(3)310(2)
0.27	BI	6	17.5	18	15	400	F861BI274(1)310(2)
Capacitance Value (µF)	Size Code	B (mm)	H (mm)	L (mm)	Lead Spacing (p)	dV/dt (V/µs)	Part Number

(1) M = ±20%, K = ±10%.

(2) Insert lead and packaging code. See Ordering Options Table for available options.

(3) M = ±20% (only available tolerance).



Table 1 – Ratings &amp; Part Number Reference cont'd

Capacitance Value ( $\mu\text{F}$ )	Size Code	Maximum Dimensions in mm			Lead Spacing (p)	dV/dt (V/ $\mu\text{s}$ )	Part Number
		B	H	L			
0.27	BK	7.5	13.5	18	15	400	F861BK274(1)310(2)
0.27	BR	13	12	18	15	400	F861BR274(1)310(2)
0.27	BT	9	12.5	18	15	400	F861BT274(1)310(2)
0.33	BI	6	17.5	18	15	400	F861BI334(1)310(2)
0.33	BK	7.5	13.5	18	15	400	F861BK334(1)310(2)
0.33	BR	13	12	18	15	400	F861BR334(1)310(2)
0.33	BT	9	12.5	18	15	400	F861BT334(1)310(2)
0.39	BI	6	17.5	18	15	400	F861BI394(1)310(2)
0.39	BK	7.5	13.5	18	15	400	F861BK394(3)310(2)
0.39	BP	8.5	14.5	18	15	400	F861BP394(1)310(2)
0.39	BR	13	12	18	15	400	F861BR394(1)310(2)
0.39	BT	9	12.5	18	15	400	F861BT394(1)310(2)
0.47	BO	7.5	18.5	18	15	400	F861BO474(1)310(2)
0.47	BP	8.5	14.5	18	15	400	F861BP474(1)310(2)
0.47	BR	13	12	18	15	400	F861BR474(1)310(2)
0.56	BO	7.5	18.5	18	15	400	F861BO564(1)310(2)
0.56	BR	13	12	18	15	400	F861BR564(1)310(2)
0.56	BS	10	16	18	15	400	F861BS564(1)310(2)
0.68	BR	13	12	18	15	400	F861BR684(3)310(2)
0.68	BS	10	16	18	15	400	F861BS684(1)310(2)
0.82	BY	11	19	18	15	400	F861BY824(1)310(2)
1	BZ	12	20	18	15	400	F861BZ105(3)310(2)
0.039	DB	6	14.5	26	22.5	200	F861DB393(1)310(2)
0.047	DB	6	14.5	26	22.5	200	F861DB473(1)310(2)
0.056	DB	6	14.5	26	22.5	200	F861DB563(1)310(2)
0.068	DB	6	14.5	26	22.5	200	F861DB683(1)310(2)
0.082	DB	6	14.5	26	22.5	200	F861DB823(1)310(2)
0.1	DB	6	14.5	26	22.5	200	F861DB104(1)310(2)
0.12	DB	6	14.5	26	22.5	200	F861DB124(1)310(2)
0.15	DB	6	14.5	26	22.5	200	F861DB154(1)310(2)
0.18	DB	6	14.5	26	22.5	200	F861DB184(1)310(2)
0.22	DB	6	14.5	26	22.5	200	F861DB224(1)310(2)
0.25	DB	6	14.5	26	22.5	200	F861DB254(1)310(2)
0.27	DB	6	14.5	26	22.5	200	F861DB274(1)310(2)
0.33	DB	6	14.5	26	22.5	200	F861DB334(1)310(2)
0.39	DB	6	14.5	26	22.5	200	F861DB394(1)310(2)
0.47	DB	6	14.5	26	22.5	200	F861DB474(3)310(2)
0.47	DI	7	16	26	22.5	200	F861DI474(1)310(2)
0.56	DI	7	16	26	22.5	200	F861DI564(1)310(2)
0.68	DI	7	16	26	22.5	200	F861DI684(1)310(2)
0.82	DH	8	16	26	22.5	200	F861DH824(1)310(2)
1	DJ	8.5	17	26	22.5	200	F861DJ105(3)310(2)
1.2	DM	9	18.5	26	22.5	200	F861DM125(3)310(2)
1.2	DO	10	18.5	26	22.5	200	F861DO125(1)310(2)
1.5	DP	11	20	26	22.5	200	F861DP155(1)310(2)
1.8	DP	11	20	26	22.5	200	F861DP185(3)310(2)
1.8	DU	13	22	26	22.5	200	F861DU185(1)310(2)
2.2	DU	13	22	26	22.5	200	F861DU225(1)310(2)
2.5	DU	13	22	26	22.5	200	F861DU255(3)310(2)
2.5	DY	15.5	24.5	26	22.5	200	F861DY255(1)310(2)
2.7	DY	15.5	24.5	26	22.5	200	F861DY275(1)310(2)
3.3	DY	15.5	24.5	26	22.5	200	F861DY335(3)310(2)
0.15	FB	9	17	31.5	27.5	150	F861FB154(1)310(2)
0.18	FB	9	17	31.5	27.5	150	F861FB184(1)310(2)
0.22	FB	9	17	31.5	27.5	150	F861FB224(1)310(2)
0.25	FB	9	17	31.5	27.5	150	F861FB254(1)310(2)
0.25	FH	21	12.5	31.5	27.5	150	F861FH254(1)310(2)
0.27	FB	9	17	31.5	27.5	150	F861FB274(1)310(2)
0.27	FH	21	12.5	31.5	27.5	150	F861FH274(1)310(2)
Capacitance Value ( $\mu\text{F}$ )	Size Code	B (mm)	H (mm)	L (mm)	Lead Spacing (p)	dV/dt (V/ $\mu\text{s}$ )	Part Number

(1)  $M = \pm 20\%$ ,  $K = \pm 10\%$ .

(2) Insert lead and packaging code. See Ordering Options Table for available options.

(3)  $M = \pm 20\%$  (only available tolerance).

Table 1 – Ratings &amp; Part Number Reference cont'd

Capacitance Value ( $\mu\text{F}$ )	Size Code	Maximum Dimensions in mm			Lead Spacing (p)	dV/dt (V/ $\mu\text{s}$ )	Part Number
		B	H	L			
0.33	FB	9	17	31.5	27.5	150	F861FB334(1)310(2)
0.33	FH	21	12.5	31.5	27.5	150	F861FH334(1)310(2)
0.39	FB	9	17	31.5	27.5	150	F861FB394(1)310(2)
0.39	FH	21	12.5	31.5	27.5	150	F861FH394(1)310(2)
0.47	FB	9	17	31.5	27.5	150	F861FB474(1)310(2)
0.47	FH	21	12.5	31.5	27.5	150	F861FH474(1)310(2)
0.56	FB	9	17	31.5	27.5	150	F861FB564(1)310(2)
0.56	FH	21	12.5	31.5	27.5	150	F861FH564(1)310(2)
0.68	FB	9	17	31.5	27.5	150	F861FB684(1)310(2)
0.68	FH	21	12.5	31.5	27.5	150	F861FH684(1)310(2)
0.82	FB	9	17	31.5	27.5	150	F861FB824(1)310(2)
0.82	FH	21	12.5	31.5	27.5	150	F861FH824(1)310(2)
1	FB	9	17	31.5	27.5	150	F861FB105(1)310(2)
1	FH	21	12.5	31.5	27.5	150	F861FH105(1)310(2)
1.2	FB	9	17	31.5	27.5	150	F861FB125(3)310(2)
1.2	FC	11	20	31.5	27.5	150	F861FC125(1)310(2)
1.2	FH	21	12.5	31.5	27.5	150	F861FH125(1)310(2)
1.5	FC	11	20	31.5	27.5	150	F861FC155(1)310(2)
1.5	FH	21	12.5	31.5	27.5	150	F861FH155(1)310(2)
1.8	FC	11	20	31.5	27.5	150	F861FC185(3)310(2)
1.8	FH	21	12.5	31.5	27.5	150	F861FH185(1)310(2)
2.2	FH	21	12.5	31.5	27.5	150	F861FH225(3)310(2)
2.2	FI	13	25	31.5	27.5	150	F861FI225(1)310(2)
2.5	FI	13	25	31.5	27.5	150	F861FI255(1)310(2)
2.5	FQ	27.5	16	31.5	27.5	150	F861FQ255(1)310(2)
2.7	FI	13	25	31.5	27.5	150	F861FI275(1)310(2)
2.7	FQ	27.5	16	31.5	27.5	150	F861FQ275(1)310(2)
3.3	FI	13	25	31.5	27.5	150	F861FI335(3)310(2)
3.3	FN	14	28	31.5	27.5	150	F861FN335(1)310(2)
3.3	FO	17	40	31.5	27.5	150	F861FO335(1)310(2)
3.3	FQ	27.5	16	31.5	27.5	150	F861FQ335(1)310(2)
3.9	FO	17	40	31.5	27.5	150	F861FO395(1)310(2)
3.9	FQ	27.5	16	31.5	27.5	150	F861FQ395(3)310(2)
3.9	FR	17.5	28	31.5	27.5	150	F861FR395(1)310(2)
3.9	FT	31	19	31.5	27.5	150	F861FT395(1)310(2)
4.7	FO	17	40	31.5	27.5	150	F861FO475(1)310(2)
4.7	FR	17.5	28	31.5	27.5	150	F861FR475(1)310(2)
4.7	FT	31	19	31.5	27.5	150	F861FT475(1)310(2)
5.6	FO	17	40	31.5	27.5	150	F861FO565(1)310(2)
5.6	FS	19	29	31.5	27.5	150	F861FS565(3)310(2)
5.6	FT	31	19	31.5	27.5	150	F861FT565(3)310(2)
6.8	FO	17	40	31.5	27.5	150	F861FO685(3)310(2)
6.8	FY	22	37	31.5	27.5	150	F861FY685(1)310(2)
8.2	FY	22	37	31.5	27.5	150	F861FY825(1)310(2)
0.33	RB	11	22	41	37.5	100	F861RB334(1)310(2)
0.39	RB	11	22	41	37.5	100	F861RB394(1)310(2)
0.47	RB	11	22	41	37.5	100	F861RB474(1)310(2)
0.56	RB	11	22	41	37.5	100	F861RB564(1)310(2)
0.56	RV	24	15	41	37.5	100	F861RV564(1)310(2)
0.68	RB	11	22	41	37.5	100	F861RB684(1)310(2)
0.68	RV	24	15	41	37.5	100	F861RV684(1)310(2)
0.82	RB	11	22	41	37.5	100	F861RB824(1)310(2)
0.82	RV	24	15	41	37.5	100	F861RV824(1)310(2)
1	RB	11	22	41	37.5	100	F861RB105(1)310(2)
1	RV	24	15	41	37.5	100	F861RV105(1)310(2)
1.2	RB	11	22	41	37.5	100	F861RB125(1)310(2)
1.2	RV	24	15	41	37.5	100	F861RV125(1)310(2)
1.5	RB	11	22	41	37.5	100	F861RB155(1)310(2)
1.5	RV	24	15	41	37.5	100	F861RV155(1)310(2)
Capacitance Value ( $\mu\text{F}$ )	Size Code	B (mm)	H (mm)	L (mm)	Lead Spacing (p)	dV/dt (V/ $\mu\text{s}$ )	Part Number

(1)  $M = \pm 20\%$ ,  $K = \pm 10\%$ .

(2) Insert lead and packaging code. See Ordering Options Table for available options.

(3)  $M = \pm 20\%$  (only available tolerance).

Table 1 – Ratings &amp; Part Number Reference cont'd

Capacitance Value ( $\mu\text{F}$ )	Size Code	Maximum Dimensions in mm			Lead Spacing (p)	dV/dt (V/ $\mu\text{s}$ )	Part Number
		B	H	L			
1.8	RB	11	22	41	37.5	100	F861RB185(1)310(2)
1.8	RV	24	15	41	37.5	100	F861RV185(1)310(2)
2.2	RB	11	22	41	37.5	100	F861RB225(1)310(2)
2.2	RV	24	15	41	37.5	100	F861RV225(1)310(2)
2.5	RB	11	22	41	37.5	100	F861RB255(1)310(2)
2.5	RV	24	15	41	37.5	100	F861RV255(1)310(2)
2.7	RB	11	22	41	37.5	100	F861RB275(1)310(2)
2.7	RV	24	15	41	37.5	100	F861RV275(1)310(2)
3.3	RB	11	22	41	37.5	100	F861RB335(3)310(2)
3.3	RF	13	24	41	37.5	100	F861RF335(1)310(2)
3.3	RV	24	15	41	37.5	100	F861RV335(1)310(2)
3.9	RF	13	24	41	37.5	100	F861RF395(1)310(2)
3.9	RV	24	15	41	37.5	100	F861RV395(1)310(2)
4.7	RF	13	24	41	37.5	100	F861RF475(3)310(2)
4.7	RH	15	26	41	37.5	100	F861RH475(1)310(2)
4.7	RV	24	15	41	37.5	100	F861RV475(3)310(2)
4.7	RW	24	19	41	37.5	100	F861RW475(1)310(2)
5.6	RH	15	26	41	37.5	100	F861RH565(1)310(2)
5.6	RW	24	19	41	37.5	100	F861RW565(1)310(2)
6.8	RC	16	28.5	41	37.5	100	F861RC685(3)310(2)
6.8	RD	19	32	41	37.5	100	F861RD685(1)310(2)
6.8	RW	24	19	41	37.5	100	F861RW685(3)310(2)
8.2	RD	19	32	41	37.5	100	F861RD825(1)310(2)
10	RP	21	38	41	37.5	100	F861RP106(1)310(2)
12	RO	24	44	41	37.5	100	F861RO126(1)310(2)
12	RP	21	38	41	37.5	100	F861RP126(3)310(2)
15	RO	24	44	41	37.5	100	F861RO156(1)310(2)
18	RU	30	45	41	37.5	100	F861RU186(1)310(2)
22	RU	30	45	41	37.5	100	F861RU226(1)310(2)
3.9	GD	30	45	57.5	52.5	100	F861GD395(1)310(2)
4.7	GD	30	45	57.5	52.5	100	F861GD475(1)310(2)
5.6	GD	30	45	57.5	52.5	100	F861GD565(1)310(2)
6.8	GD	30	45	57.5	52.5	100	F861GD685(1)310(2)
8.2	GD	30	45	57.5	52.5	100	F861GD825(1)310(2)
10	GD	30	45	57.5	52.5	100	F861GD106(1)310(2)
12	GD	30	45	57.5	52.5	100	F861GD126(1)310(2)
15	GD	30	45	57.5	52.5	100	F861GD156(1)310(2)
18	GD	30	45	57.5	52.5	100	F861GD186(1)310(2)
22	GD	30	45	57.5	52.5	100	F861GD226(1)310(2)
25	GD	30	45	57.5	52.5	100	F861GD256(1)310(2)
27	GD	30	45	57.5	52.5	100	F861GD276(1)310(2)
33	GD	30	45	57.5	52.5	100	F861GD336(3)310(2)
39	GE	35	50	57.5	52.5	100	F861GE396(1)310(2)
45	GE	35	50	57.5	52.5	100	F861GE456(3)310(2)
Capacitance Value ( $\mu\text{F}$ )	Size Code	B (mm)	H (mm)	L (mm)	Lead Spacing (p)	dV/dt (V/ $\mu\text{s}$ )	Part Number

(1)  $M = \pm 20\%$ ,  $K = \pm 10\%$ .

(2) Insert lead and packaging code. See Ordering Options Table for available options.

(3)  $M = \pm 20\%$  (only available tolerance).

## Soldering Process

The implementation of the RoHS directive has resulted in the selection of SnAgCu (SAC) alloys or SnCu alloys as primary solder. This has increased the liquidus temperature from that of 183°C for SnPb eutectic alloy to 217 – 221°C for the new alloys. As a result, the heat stress to the components, even in wave soldering, has increased considerably due to higher pre-heat and wave temperatures. Polypropylene capacitors are especially sensitive to heat (the melting point of polypropylene is 160 – 170°C). Wave soldering can be destructive, especially for mechanically small polypropylene capacitors (with lead spacing of 5 mm to 15 mm), and great care has to be taken during soldering. The recommended solder profiles from KEMET should be used. Please consult KEMET with any questions. In general, the wave soldering curve from IEC Publication 61760-1 Edition 2 serves as a solid guideline for successful soldering. Please see Figure 1.

Reflow soldering is not recommended for through-hole film capacitors. Exposing capacitors to a soldering profile in excess of the above the recommended limits may result to degradation or permanent damage to the capacitors.

Do not place the polypropylene capacitor through an adhesive curing oven to cure resin for surface mount components. Insert through-hole parts after the curing of surface mount parts. Consult KEMET to discuss the actual temperature profile in the oven, if through-hole components must pass through the adhesive curing process. A maximum two soldering cycles is recommended. Please allow time for the capacitor surface temperature to return to a normal temperature before the second soldering cycle.

Figure 1

Dielectric Film Material	Maximum Preheat Temperature			Maximum Peak Soldering Temperature	
	Capacitor Lead Spacing <10 mm	Capacitor Lead Spacing = 15 mm	Capacitor Lead Spacing >15 mm	Capacitor Lead Spacing <15 mm	Capacitor Lead Spacing >15 mm
Polyester	130°C	130°C	130°C	270°C	270°C
Polypropylene	100°C	110°C	130°C	260°C	270°C
Polyphenylene Sulphide	150°C	150°C	160°C	270°C	270°C

## Wave Soldering Recommendations

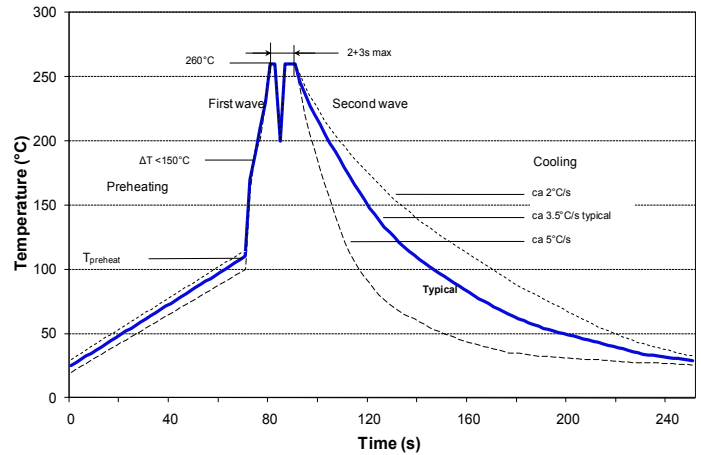

## Manual Soldering Recommendations

Following is the recommendation for manual soldering with a soldering iron.

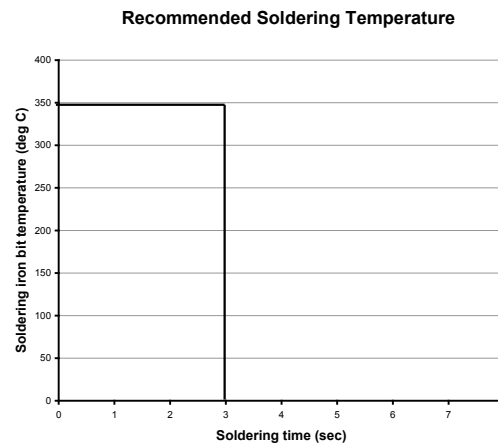

The soldering iron tip temperature should be set at 350°C (+10°C maximum) with the soldering duration not to exceed more than 3 seconds.

## Soldering Process cont'd

### Selective Soldering Recommendations

Selective dip soldering is a variation of reflow soldering. In this method, the printed circuit board with through-hole components to be soldered is preheated and transported over the solder bath as in normal flow soldering without touching the solder. When the board is over the bath, it is stopped and pre-designed solder pots are lifted from the bath with molten solder only at the places of the selected components, and pressed against the lower surface of the board to solder the components.

The temperature profile for selective soldering is similar to the double wave flow soldering outlined in this document, **however, instead of two baths, there is only one bath with a time from 3 to 10 seconds.** In selective soldering, the risk of overheating is greater than in double wave flow soldering, and great care must be taken so that the parts are not overheated.

## Construction

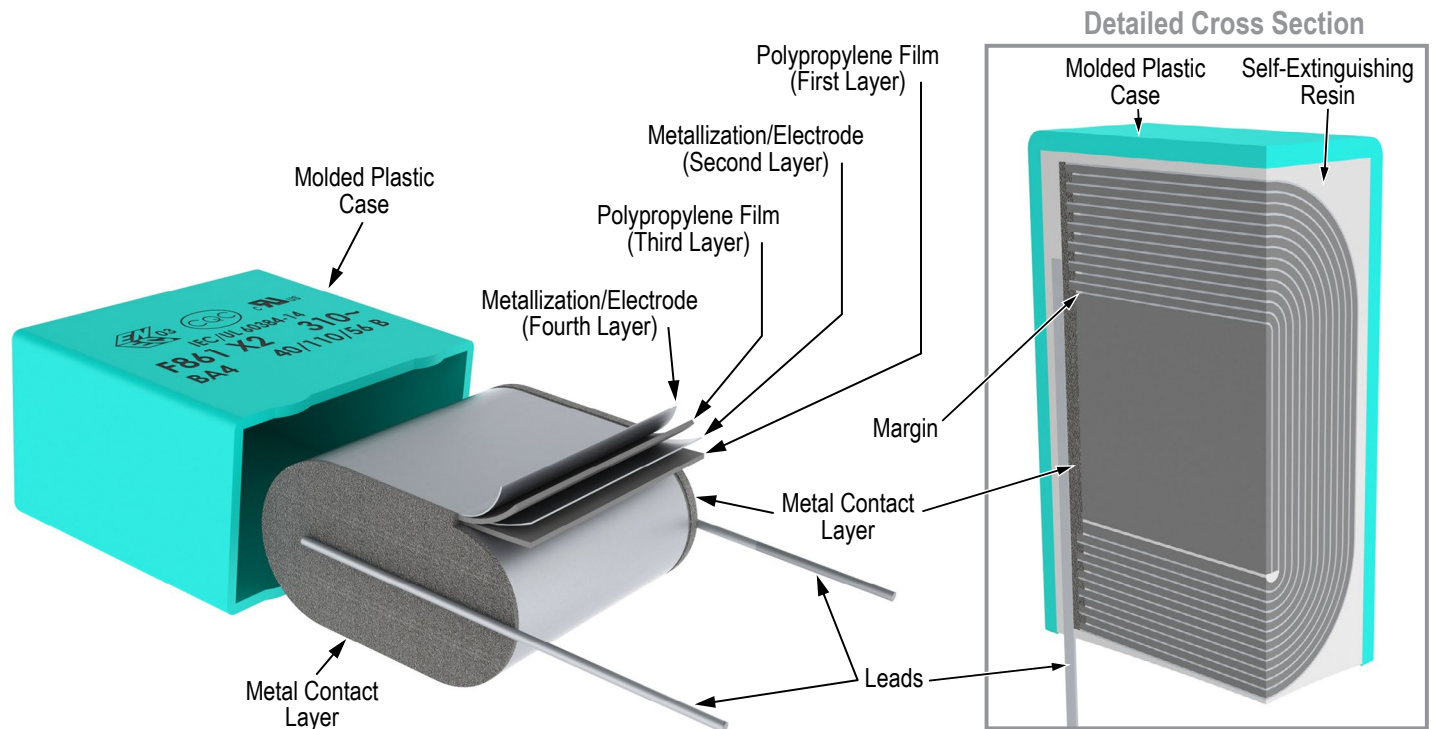

## Marking

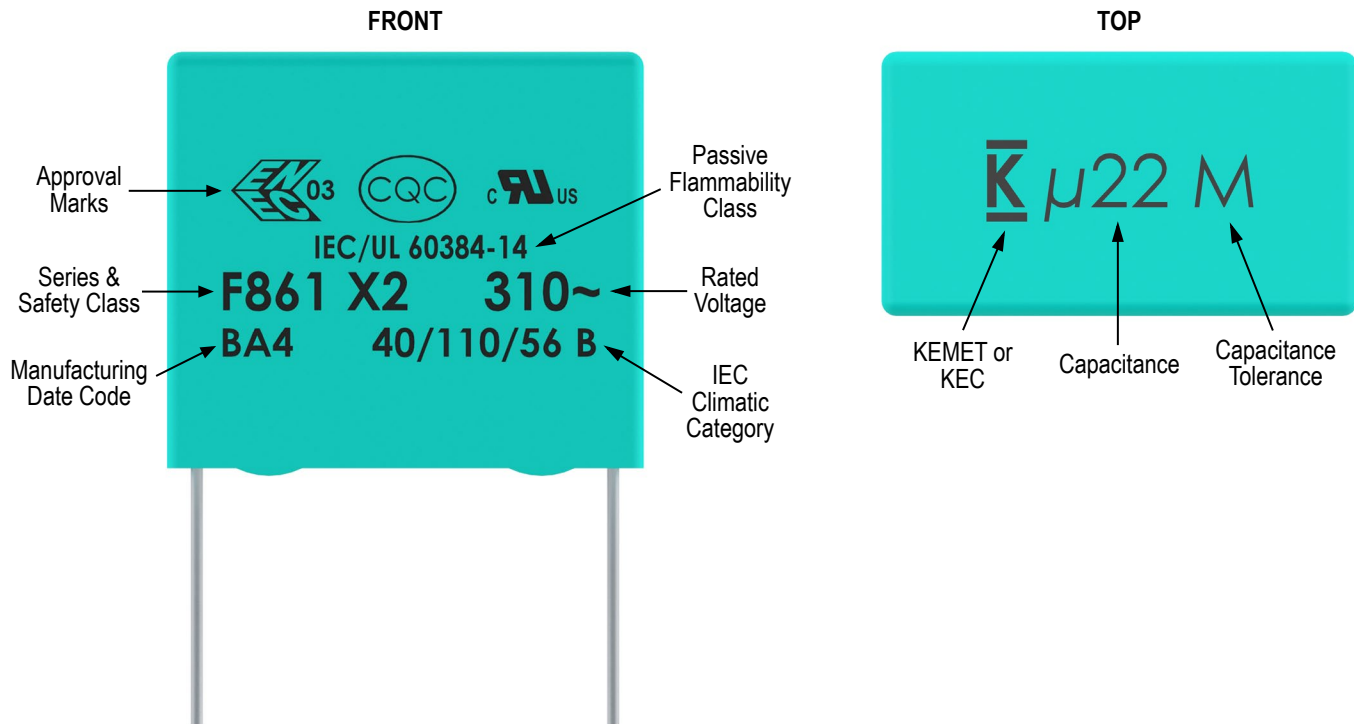

## Packaging Quantities

Size Code	Lead Spacing	Thickness (mm)	Height (mm)	Length (mm)	Bulk Short Leads	Bulk Long Leads	Standard Reel ø 355 mm	Large Reel ø 500 mm	Ammo	Pizza
KE	7.5	2.5	6	10	2000	2500	2500		3500	
KF		3	8	10	1500	1750	2100		2800	
KG		4	8	10	2000	1500	1500		2100	
KJ		5	10.5	10	1500	1000	1200		1600	
KM		6	12	10.5	1000	800	1000		1350	
KH		4	9	10	2000	1500	1500		2100	
AN	10	3.5	9	13	2000	2200	850	1700	1150	
AG		4	9	13	2000	2200	750	1500	1000	
AK		5	11	13	1300	2000	600	1250	800	
AP		6	12	13	1000	1800	500	1000	680	
AO		7	17	13	600	700	450	900	580	
AL		9.5	7.5	13	1000	1500	300	600	430	
AE		4	8	13	2000	2200	750	1500	1000	
BB	15	4	10	18	2500	1500	750	1500	1000	1411
BC		5	11	18	1000	1250	600	1250	800	1139
BE		5.5	12.5	18	800	1000	550	1100	750	1020
BG		6	12	18	1750	1000	500	1000	680	935
BK		7.5	13.5	18	1000	800	350	800	500	748
BI		6	17.5	18	1000	800	500	1000	680	935
BP		8.5	14.5	18	1000	650	300	700	440	663
BT		9	12.5	18	1000	700	270	650	410	629
BO		7.5	18.5	18	900	500	350	800	500	748
BS		10	16	18	750	550	300	600	380	561
BR		13	12	18	750	520	200	480	280	425
BY		11	19	18	450	400	250	500	340	510
BA		8.5	12.5	18	1000	650	300	700	440	663
BZ		12	20	18	350	300	220	450	330	459
DB	22.5	6	14.5	26	805	450	300	700	464	660
DI		7	16	26	700	450	250	550	380	564
DH		8.0	16.0	26	520	300	240	500	330	492
DJ		8.5	17	26	450	350	250	450	280	468
DM		9	18.5	26	400	225	200	400	300	444
DO		10	18.5	26	360	350	160	350	235	396
DP		11	20	26	300	200	190	350	217	360
DU		13	22	26	230	150	150	300	200	300
DY		15.5	24.5	26	150	100	120	250	170	252

### Packaging Quantities cont'd

Size Code	Lead Spacing	Thickness (mm)	Height (mm)	Length (mm)	Bulk Short Leads	Bulk Long Leads	Standard Reel ø 355 mm	Large Reel ø 500 mm	Ammo	Pizza
FB	27.5	9.0	17.0	31.5						370
FC		11.0	20.0	31.5						300
FI		13.0	25.0	31.5						250
FN		14.0	28.0	31.5						230
FO		17.0	40.0	31.5						190
FR		17.5	28.0	31.5						190
FS		19.0	29.0	31.5						170
FY		22.0	37.0	31.5						150
FH		21.0	12.5	31.5						150
FQ		27.5	16.0	31.5						120
FT		31.0	19.0	31.5						100
RB	37.5	11.0	22.0	41.0						210
RF		13.0	24.0	41.0						175
RH		15.0	26.0	41.0						154
RC		16.0	28.5	41.0						140
RD		19.0	32.0	41.0						119
RP		21.0	38.0	41.0						105
RO		24.0	44.0	41.0						91
RU		30.0	45.0	41.0						77
RV		24.0	15.0	41.0						91
RW		24.0	19.0	41.0						91
GD	52.5	30	45	57.5						55
GE		35	50	57.5						45



## Lead Taping & Packaging (IEC 60286–2)

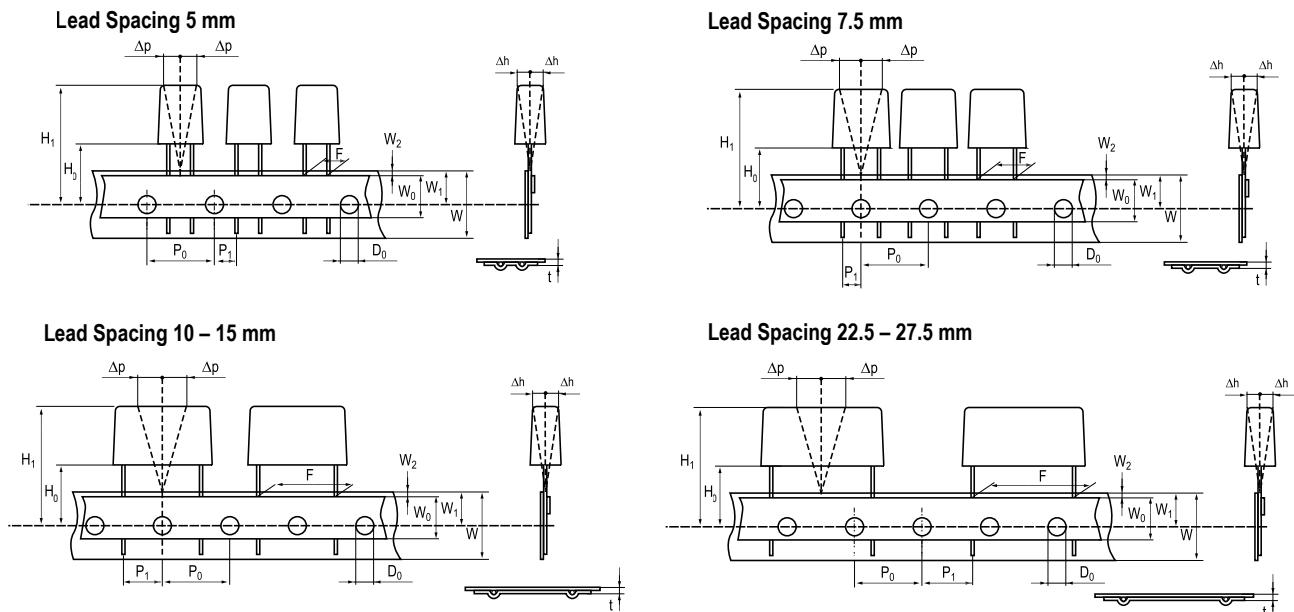

## Taping Specification

Dimensions in mm									Standard IEC 60286–2
Lead spacing	+6/-0.1	F	5	7.5	10	15	22.5	27.5	F
Carrier tape width	+1/-0.5	W	18	18	18	18	18	18	18 <sup>+1/-0.5</sup>
Hold-down tape width	Minimum	W <sub>0</sub>	6	6	9	10	10	10	
Position of sprocket hole	+/-0.5	W <sub>1</sub>	9	9	9	9	9	9	9 <sup>+0.75/-0.5</sup>
Distance between tapes	Maximum	W <sub>2</sub>	3	3	3	3	3	3	3
Sprocket hole diameter	+/-0.2	D <sub>0</sub>	4	4	4	4	4	4	4
Feed hole lead spacing	+/-0.2 <sup>(1)</sup>	P <sub>0</sub> <sup>(3)</sup>	12.7	12.7	12.7	12.7	12.7	12.7	12.7
Distance lead – feed hole	+/-0.7	P <sub>1</sub>	3.85	3.75	7.7	5.2	7.8	5.3	P <sup>1</sup>
Deviation tape – plane	Maximum	Δp	1.3	1.3	1.3	1.3	1.3	1.3	1.3
Lateral deviation	+/-2	Δh	2	2	2	2	2	2	2
Total thickness	+/-0.2	t	0.7	0.7	0.7	0.7	0.9 <sup>MAX</sup>	0.9 <sup>MAX</sup>	0.9 <sup>MAX</sup>
Sprocket hole/cap body	+/-0.5	H <sub>0</sub> <sup>(2)</sup>	18.5 <sup>+/-0.5</sup>	18.5 <sup>+/-0.5</sup>	18.5 <sup>+/-0.5</sup>	18.5 <sup>+/-0.5</sup>	18.5 <sup>+/-0.5</sup>	18.5 <sup>+/-0.5</sup>	18 <sup>+2/-0</sup>

(1) Maximum cumulative feed hole error, 1 mm per 20 parts.

(2) 16.5 mm available on request.

(3) 15 mm available on request (F ≥ 10 mm).

## Lead Taping & Packaging (IEC 60286–2) cont'd

### Ammo Specifications

Series	Dimensions (mm)		
	H	W	T
R4x, R4x+R, R7x, RSB	360	340	59
F5A, F5B, F5D			
F6xx, F8xx			
PHExxx, PMExxx, PMRxxx	330	330	50

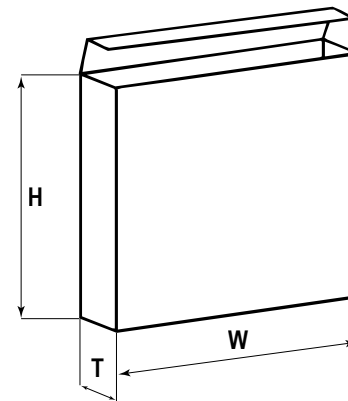

### Reel Specifications

Series	Dimensions (mm)		
	D	H	W
R4x, R4x+R, R7x, RSB	355 500	30	55 (Max)
F5A, F5B, F5D		25	
F6xx, F8xx			
PHExxx, PMExxx, PMRxxx	360 500	30	46 (Max)

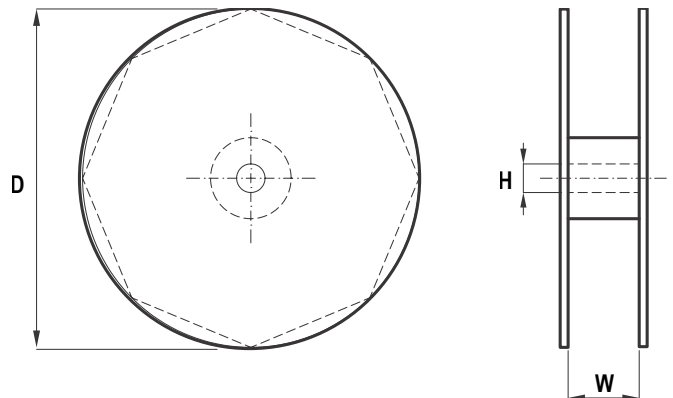

### Manufacturing Date Code (IEC–60062)

Y = Year, Z = Month			
Year	Code	Month	Code
2000	M	January	1
2001	N	February	2
2002	P	March	3
2003	R	April	4
2004	S	May	5
2005	T	June	6
2006	U	July	7
2007	V	August	8
2008	W	September	9
2009	X	October	O
2010	A	November	N
2011	B	December	D
2012	C		
2013	D		
2014	E		
2015	F		
2016	H		
2017	J		
2018	K		
2019	L		
2020	M		

## KEMET Corporation World Headquarters

2835 KEMET Way  
Simpsonville, SC 29681

Mailing Address:  
P.O. Box 5928  
Greenville, SC 29606

www.kemet.com  
Tel: 864-963-6300  
Fax: 864-963-6521

**Corporate Offices**  
Fort Lauderdale, FL  
Tel: 954-766-2800

## North America

**Southeast**  
Lake Mary, FL  
Tel: 407-855-8886

**Northeast**  
Wilmington, MA  
Tel: 978-658-1663

**Central**  
Novi, MI  
Tel: 248-306-9353

**West**  
Milpitas, CA  
Tel: 408-433-9950

**Mexico**  
Guadalajara, Jalisco  
Tel: 52-33-3123-2141

## Europe

**Southern Europe**  
Paris, France  
Tel: 33-1-4646-1006

Sasso Marconi, Italy  
Tel: 39-051-939111

**Central Europe**  
Landsberg, Germany  
Tel: 49-8191-3350800

Kamen, Germany  
Tel: 49-2307-438110

**Northern Europe**  
Bishop's Stortford, United Kingdom  
Tel: 44-1279-460122

Espoo, Finland  
Tel: 358-9-5406-5000

## Asia

**Northeast Asia**  
Hong Kong  
Tel: 852-2305-1168

Shenzhen, China  
Tel: 86-755-2518-1306

Beijing, China  
Tel: 86-10-5829-1711

Shanghai, China  
Tel: 86-21-6447-0707

Taipei, Taiwan  
Tel: 886-2-27528585

**Southeast Asia**  
Singapore  
Tel: 65-6586-1900

Penang, Malaysia  
Tel: 60-4-6430200

Bangalore, India  
Tel: 91-806-53-76817

*Note: KEMET reserves the right to modify minor details of internal and external construction at any time in the interest of product improvement. KEMET does not assume any responsibility for infringement that might result from the use of KEMET Capacitors in potential circuit designs. KEMET is a registered trademark of KEMET Electronics Corporation.*

## Disclaimer

All product specifications, statements, information and data (collectively, the "Information") in this datasheet are subject to change. The customer is responsible for checking and verifying the extent to which the Information contained in this publication is applicable to an order at the time the order is placed.

All Information given herein is believed to be accurate and reliable, but it is presented without guarantee, warranty, or responsibility of any kind, expressed or implied.

Statements of suitability for certain applications are based on KEMET Electronics Corporation's ("KEMET") knowledge of typical operating conditions for such applications, but are not intended to constitute – and KEMET specifically disclaims – any warranty concerning suitability for a specific customer application or use. The Information is intended for use only by customers who have the requisite experience and capability to determine the correct products for their application. Any technical advice inferred from this Information or otherwise provided by KEMET with reference to the use of KEMET's products is given gratis, and KEMET assumes no obligation or liability for the advice given or results obtained.

Although KEMET designs and manufactures its products to the most stringent quality and safety standards, given the current state of the art, isolated component failures may still occur. Accordingly, customer applications which require a high degree of reliability or safety should employ suitable designs or other safeguards (such as installation of protective circuitry or redundancies) in order to ensure that the failure of an electrical component does not result in a risk of personal injury or property damage.

Although all product-related warnings, cautions and notes must be observed, the customer should not assume that all safety measures are indicated or that other measures may not be required.