

## Tripolar protection for ISDN interfaces

### Features

- Bidirectional triple crowbar protection
- Peak pulse current:  
 $I_{PP} = 30 \text{ A}$  , 10/1000  $\mu\text{s}$
- Breakdown voltage:
  - TPI80N: 80 V
  - TPI120N: 120 V
- Available in SO-8 package
- Low dynamic breakover voltage:
  - TPI8011N: 120 V
  - TPI12011N: 170 V

### Benefits

- Low capacitance from lines to ground, allowing high speed transmission without signal attenuation
- Good capacitance balance between lines to ensure longitudinal balance
- Fixed breakdown voltage in both common and differential modes
- The same surge current capability in both common and differential modes
- A particular attention has been given to the internal wire bonding. The “4-point” configuration ensures a reliable protection, eliminating overvoltages introduced by the parasitic inductances of the wiring ( $Ld/dt$ ), especially for very fast transient overvoltages

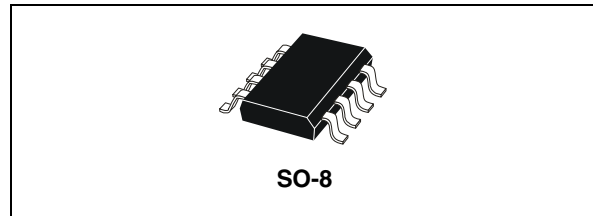

### Complies with following standards

- CCITT K17-K20
  - 10/700  $\mu\text{s}$ , 1.5 kV
  - 5/310  $\mu\text{s}$ , 38 A
- VDE 0433
  - 10/700  $\mu\text{s}$ , 2 kV
  - 5/310  $\mu\text{s}$ , 50 A
- VDE 0878
  - 1.2/50  $\mu\text{s}$ , 1.5 kV
  - 1/20  $\mu\text{s}$ , 40 A
- IEC 61000-4-2 level 4
  - 0.5/700  $\mu\text{s}$ , 1.5 kV
  - 0.2/310  $\mu\text{s}$ , 38 A

### Description

Dedicated devices for **ISDN** interface and high speed data telecom line protection. Equivalent to a triple Trisil™ with low capacitance.

**Figure 1. Functional diagram**

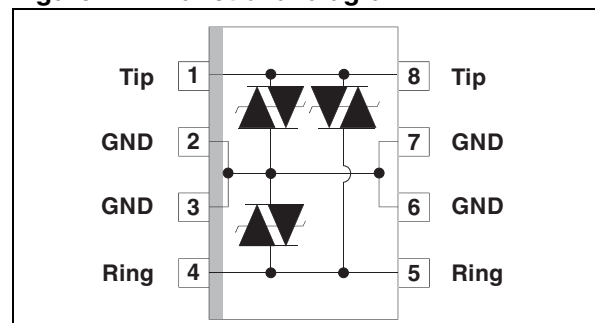

TM: Trisil is a trademark of STMicroelectronics

# 1 Characteristics

**Table 1. Absolute ratings ( $T_{amb} = 25\text{ }^{\circ}\text{C}$ )**

Symbol	Parameter	Value	Unit
$I_{PP}$	Peak pulse current (see note <sup>(1)</sup> )	10/1000 $\mu\text{s}$	30
		5/310 $\mu\text{s}$	40
		2/10 $\mu\text{s}$	90
$I_{TSM}$	Non repetitive surge peak on-state current ( $F = 50\text{ Hz}$ )	$t_p = 10\text{ ms}$	8
		$t = 1\text{ s}$	3.5
$T_{stg}$	Storage temperature range	- 55 to 150	$^{\circ}\text{C}$
$T_j$	Maximum junction temperature	150	$^{\circ}\text{C}$
$T_L$	Maximum lead temperature for soldering during 10 s.	260	$^{\circ}\text{C}$

1. See [Figure 3](#).

**Table 2. Thermal resistances**

Symbol	Parameter	Value	Unit
$R_{th(j-a)}$	Junction to ambient	170	$^{\circ}\text{C/W}$

**Table 3. Electrical characteristics ( $T_{amb} = 25\text{ }^{\circ}\text{C}$ )**

Symbol	Parameter							
$V_{RM}$	Stand-off voltage							
$V_{BR}$	Breakdown voltage							
$V_{BO}$	Breakover voltage							
$I_{RM}$	Leakage current							
$I_{PP}$	Peak pulse current							
$I_{BO}$	Breakover current							
$I_H$	Holding current							
$V_F$	Forward voltage drop							
$C$	Capacitance							
Order code	$I_{RM} @ V_{RM}$							
	max.		min.		max. note <sup>(1)</sup>	typ. note <sup>(2)</sup>	max. note <sup>(1)</sup>	min. note <sup>(3)</sup>
	$\mu\text{A}$	V	V	mA	V	V	mA	mA
TPI8011N	10	70	80	1	110	120	800	150
TPI12011N	10	105	120	1	160	170	800	150

1. See the reference test circuit 1 ([Figure 5](#).)
2. Surge test according to CCITT 1.5 kV, 10/700  $\mu\text{s}$  between Tip or Ring and ground
3. See functional holding current test circuit 2 ([Figure 6](#).)

**Figure 2.**

**Table 4. Capacitance characteristics**

CONFIGURATION	C <sub>A</sub> (pF) max.	C <sub>B</sub> (pF) max.	C <sub>A</sub> - C <sub>B</sub> (pF) max.
V <sub>A</sub> = -1 V V <sub>B</sub> = -56 V	45	15	30
V <sub>A</sub> = -56 V V <sub>B</sub> = -1 V	15	45	30

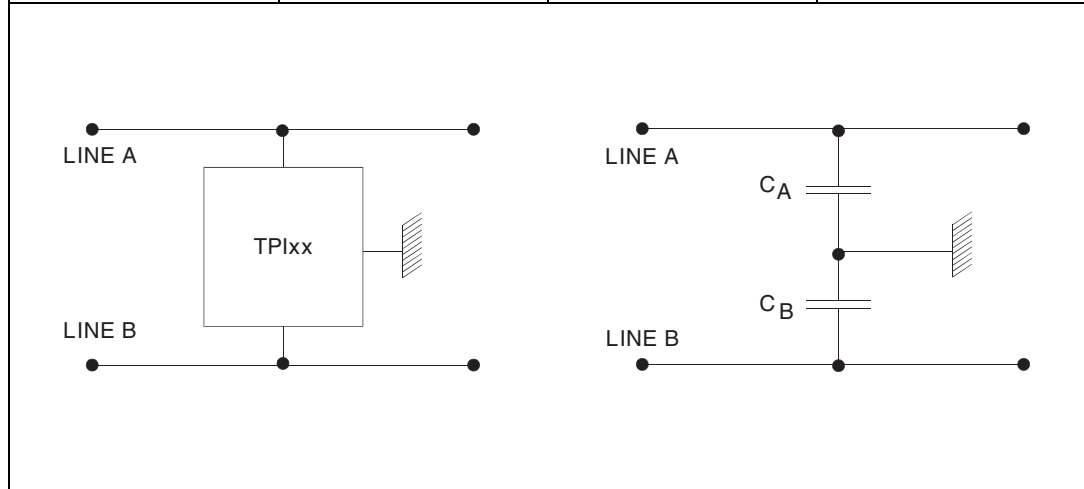

**Figure 3. Pulse waveform (10/1000 μs)**

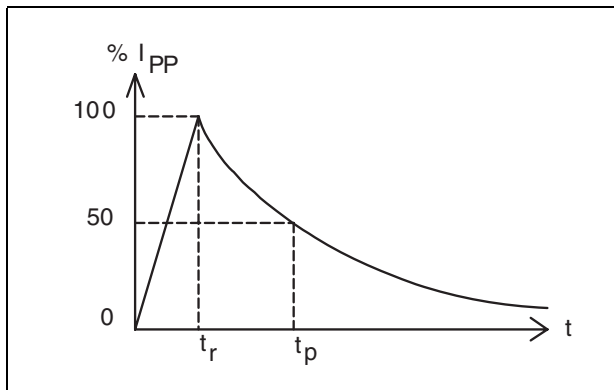

**Figure 4. Surge peak current versus overload duration**

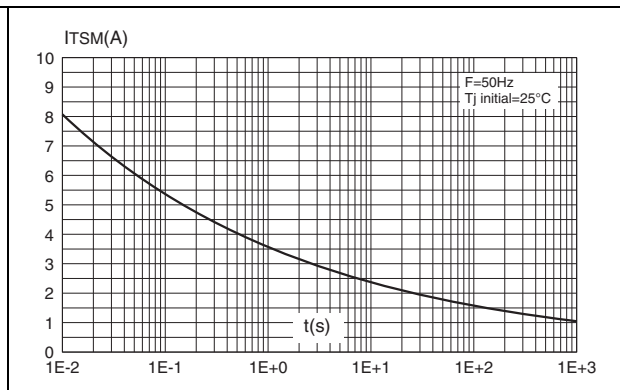

Figure 5. Reference test circuit 1

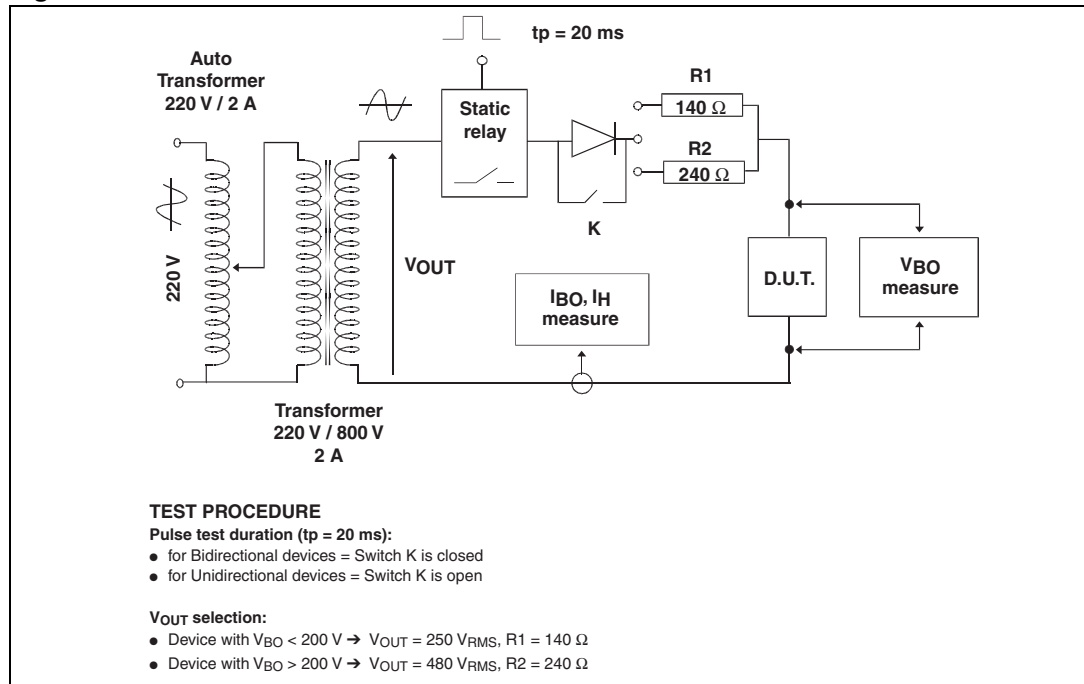
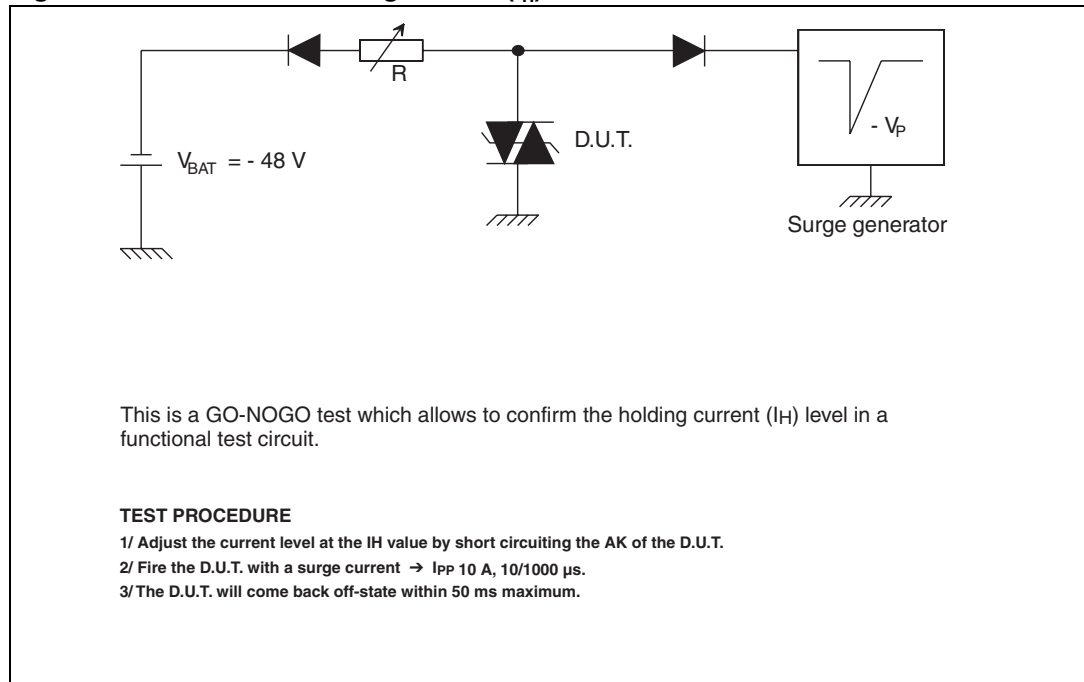

Figure 6. Functional holding current ( $I_H$ ) test circuit 2



## 2 Application information

Figure 7. Application circuit - U interface protection

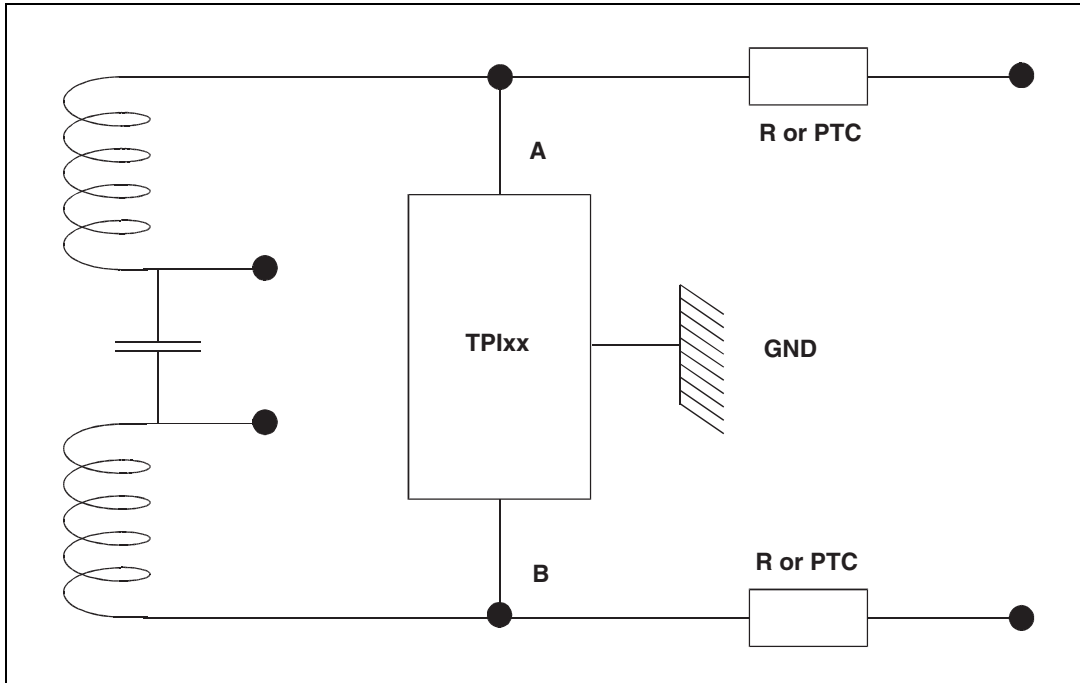
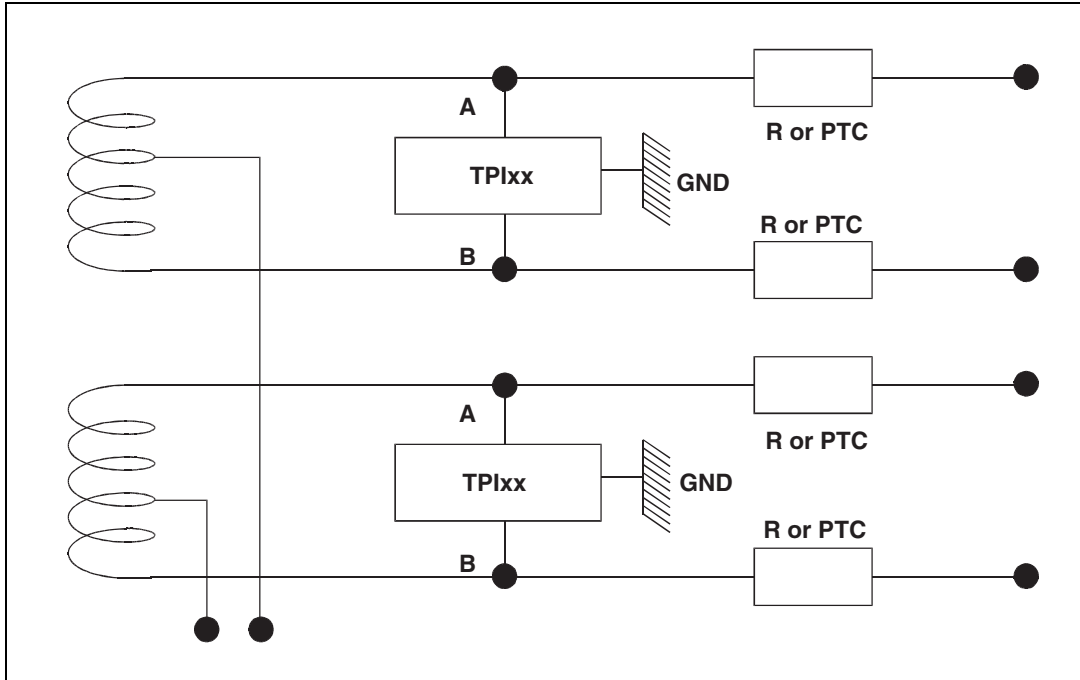
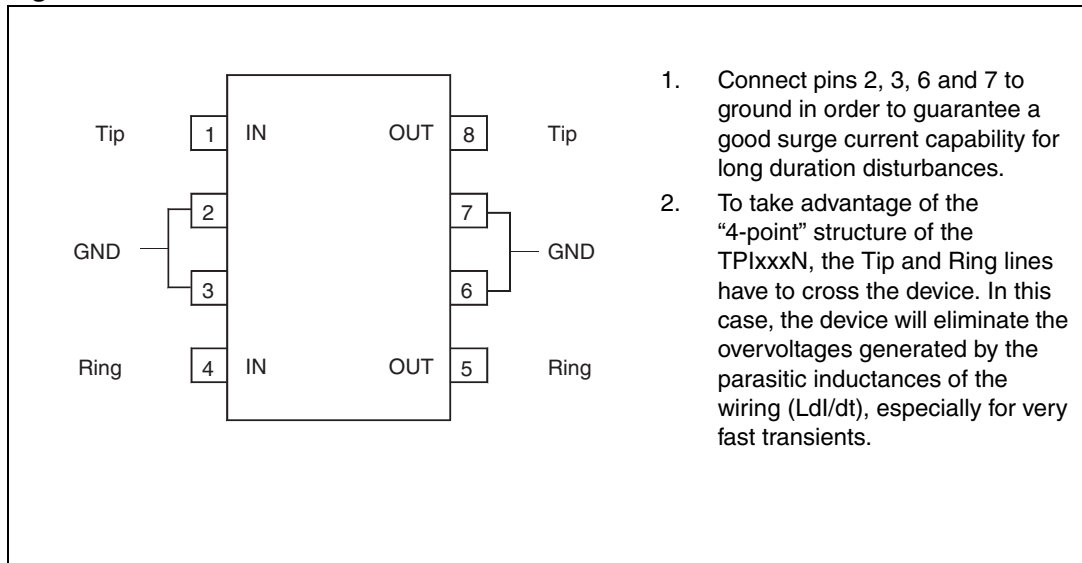

Figure 8. Application circuit - S interface protection



This component uses an internal structure resulting in symmetrical characteristics with a good balanced behaviour. Its topology ensures the same breakdown voltage level for positive and negative surges in differential and common mode.

**Figure 9. Connections**



### 3 Ordering information scheme

**Figure 10. Ordering information scheme**

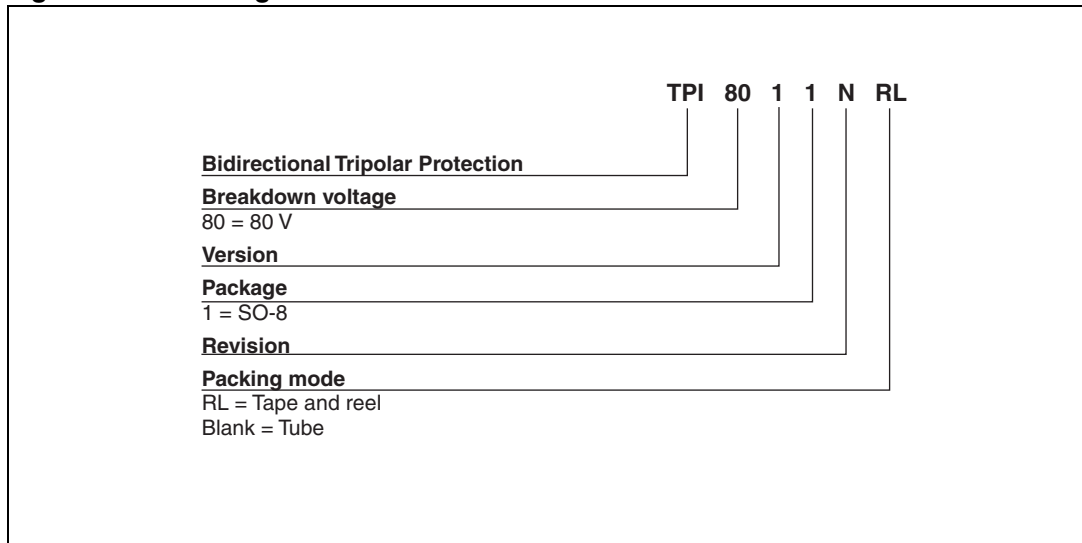

# 4 Package information

- Epoxy meets UL94, V0

In order to meet environmental requirements, ST offers these devices in ECOPACK® packages. These packages have a lead-free second level interconnect. The category of second level interconnect is marked on the package and on the inner box label, in compliance with JEDEC Standard JESD97. The maximum ratings related to soldering conditions are also marked on the inner box label. ECOPACK is an ST trademark. ECOPACK specifications are available at: [www.st.com](http://www.st.com).

**Table 5. SO-8 dimensions**

Ref.	Dimensions					
	Millimeters			Inches		
	Min.	Typ.	Max.	Min.	Typ.	Max.
A			1.75			0.069
A1	0.1		0.25	0.004		0.010
A2	1.25			0.049		
b	0.28		0.48	0.011		0.019
C	0.17		0.23	0.007		0.009
D	4.80	4.90	5.00	0.189	0.193	0.197
E	5.80	6.00	6.20	0.228	0.236	0.244
E1	3.80	3.90	4.00	0.150	0.154	0.157
e		1.27			0.050	
h	0.25		0.50	0.010		0.020
L	0.40		1.27	0.016		0.050
L1		1.04			0.041	
k	0°		8°	0°		8°
ppp			0.10			0.004

**Figure 11. SO-8 footprint, dimensions in mm (inches)**

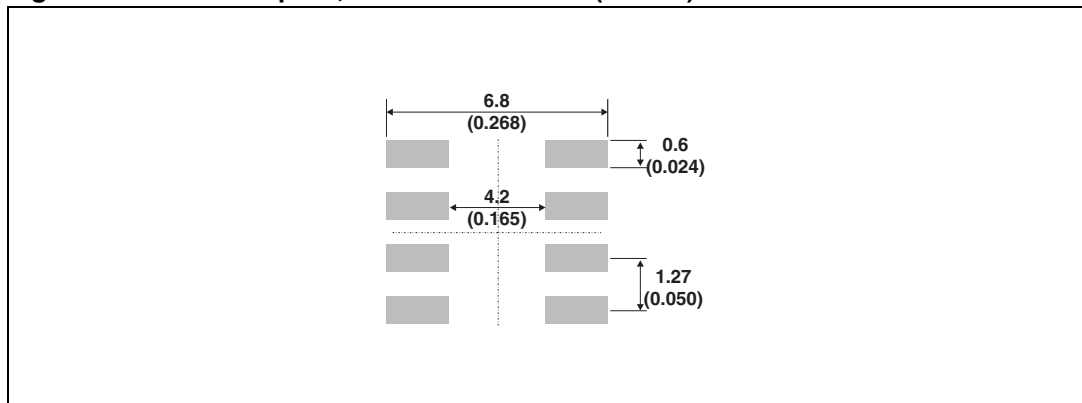

## 5 Ordering Information

**Table 6. Ordering information**

Order code	Marking	Package	Weight	Base qty	Delivery mode
TPI8011N	TP80N	SO-8	0.08 g	100	Tube
TPI8011NRL <sup>(1)</sup>	TP80N			2500	Tape and reel
TPI12011N	TP120N			100	Tube
TPI12011NRL <sup>(1)</sup>	TP120N			2500	Tape and reel

1. Preferred device

## 6 Revision history

**Table 7. Document revision history**

Date	Revision	Changes
August-2001	3A	Last update.
02-Aug-2004	4	$V_{BO}$ dyn. (page 2) and capacitances (page 3) values update.
07-Nov-2007	5	Reformatted to current standards. Updated <a href="#">Package information</a> .



**Please Read Carefully:**

Information in this document is provided solely in connection with ST products. STMicroelectronics NV and its subsidiaries ("ST") reserve the right to make changes, corrections, modifications or improvements, to this document, and the products and services described herein at any time, without notice.

All ST products are sold pursuant to ST's terms and conditions of sale.

Purchasers are solely responsible for the choice, selection and use of the ST products and services described herein, and ST assumes no liability whatsoever relating to the choice, selection or use of the ST products and services described herein.

No license, express or implied, by estoppel or otherwise, to any intellectual property rights is granted under this document. If any part of this document refers to any third party products or services it shall not be deemed a license grant by ST for the use of such third party products or services, or any intellectual property contained therein or considered as a warranty covering the use in any manner whatsoever of such third party products or services or any intellectual property contained therein.

**UNLESS OTHERWISE SET FORTH IN ST'S TERMS AND CONDITIONS OF SALE ST DISCLAIMS ANY EXPRESS OR IMPLIED WARRANTY WITH RESPECT TO THE USE AND/OR SALE OF ST PRODUCTS INCLUDING WITHOUT LIMITATION IMPLIED WARRANTIES OF MERCHANTABILITY, FITNESS FOR A PARTICULAR PURPOSE (AND THEIR EQUIVALENTS UNDER THE LAWS OF ANY JURISDICTION), OR INFRINGEMENT OF ANY PATENT, COPYRIGHT OR OTHER INTELLECTUAL PROPERTY RIGHT.**

**UNLESS EXPRESSLY APPROVED IN WRITING BY AN AUTHORIZED ST REPRESENTATIVE, ST PRODUCTS ARE NOT RECOMMENDED, AUTHORIZED OR WARRANTED FOR USE IN MILITARY, AIR CRAFT, SPACE, LIFE SAVING, OR LIFE SUSTAINING APPLICATIONS, NOR IN PRODUCTS OR SYSTEMS WHERE FAILURE OR MALFUNCTION MAY RESULT IN PERSONAL INJURY, DEATH, OR SEVERE PROPERTY OR ENVIRONMENTAL DAMAGE. ST PRODUCTS WHICH ARE NOT SPECIFIED AS "AUTOMOTIVE GRADE" MAY ONLY BE USED IN AUTOMOTIVE APPLICATIONS AT USER'S OWN RISK.**

Resale of ST products with provisions different from the statements and/or technical features set forth in this document shall immediately void any warranty granted by ST for the ST product or service described herein and shall not create or extend in any manner whatsoever, any liability of ST.

ST and the ST logo are trademarks or registered trademarks of ST in various countries.

Information in this document supersedes and replaces all information previously supplied.

The ST logo is a registered trademark of STMicroelectronics. All other names are the property of their respective owners.

© 2007 STMicroelectronics - All rights reserved

STMicroelectronics group of companies

Australia - Belgium - Brazil - Canada - China - Czech Republic - Finland - France - Germany - Hong Kong - India - Israel - Italy - Japan - Malaysia - Malta - Morocco - Singapore - Spain - Sweden - Switzerland - United Kingdom - United States of America

[www.st.com](http://www.st.com)

