

## Reference design kit for Gimbal controller for drones and handheld applications

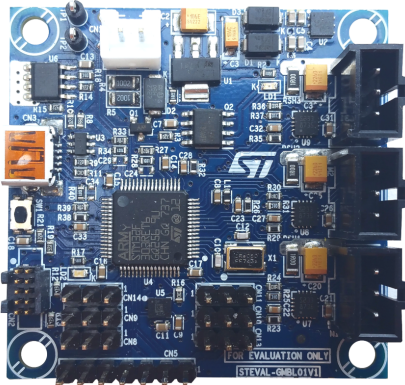

### Features

- Up to three-axis Gimbal controller.
- Compact (50 x 50 mm) design, suitable for mounting on:
  - drones
  - handheld cameras
- Three **STSPIN233** low voltage three phase and three sense motor drivers.
- **STM32F303RE** microcontroller with ARM® Cortex®-M4 core able to simultaneously drive three PMSM motors:
  - MCU runs a high efficiency field oriented control (FOC) algorithm compatible with the most common position sensors on Gimbal motors (PWM or analogic inputs)
  - compatible with open loop sensorless algorithm
- Operating voltage from 6.0 V to 8.4 V (2 LiPo batteries).
  - maximum output current 1.3 A<sub>RMS</sub>.
- Protection mechanisms:
  - triple single shunt current sensing network
  - non-dissipative overcurrent protection
  - short-circuit protection
  - thermal shutdown
  - hardware overvoltage and polarity inversion protection
- Measurement units:
  - on-board inertial measurement unit **LSM6DSL** (frame IMU)
  - compatible with external SPI/I2C inertial measurement units (camera IMU)
- Interfaces:
  - STEVAL-UKI001V1 Serial Wire Debug (SWD) board with cable
  - USB connector for real-time data communication
  - three connectors for Pitch, Roll and Tilt axis target angle inputs (PWM mode)
  - one channel DAC output and one GPIO test point for debugging purpose
- 2 Kbit serial I<sup>2</sup>C bus EEPROM for data storage
- WEEE and RoHS compliant

Product summary	
Reference design kit for Gimbal controller	<b>STEVAL-GMBL02V1</b>
Mixed signal MCU ARM Cortex-M4 core with DSP and FPU	<b>STM32F303RE</b>
Low voltage three phase and three sense motor driver	<b>STSPIN233</b>

### Description

The **STEVAL-GMBL02V1** reference design kit is a complete triple motor field-oriented control (FOC) demonstration and evaluation platform as well as an integrated environment for three axis Gimbal controller applications in the 6.0 V to 8.4 V<sub>DC</sub> bus voltage range (2 LiPo batteries), which you can increase up to 11 V with a maximum output current of 1.3 A for each motor drive.

The design features the **STM32F303RE** microcontroller with ARM® Cortex®-M4 32-bit core and the **STSPIN233** low voltage three phase and three sense motor driver.

The kit is equipped with a USB interface for real-time data exchange and includes an STEVAL-UKI001V1 ST-LINK adapter for serial wire debug (SWD) and corresponding cable. If you mount the STEVAL-UKI001V1 on the ST-LINK/V2-1 debugging section of an **STM32 Nucleo-64** board, you can program and debug the **STM32F303RE** microcontroller with a compatible toolset via USB.

## 1.1 STEVAL-GMBL01V1 controller board schematic diagrams

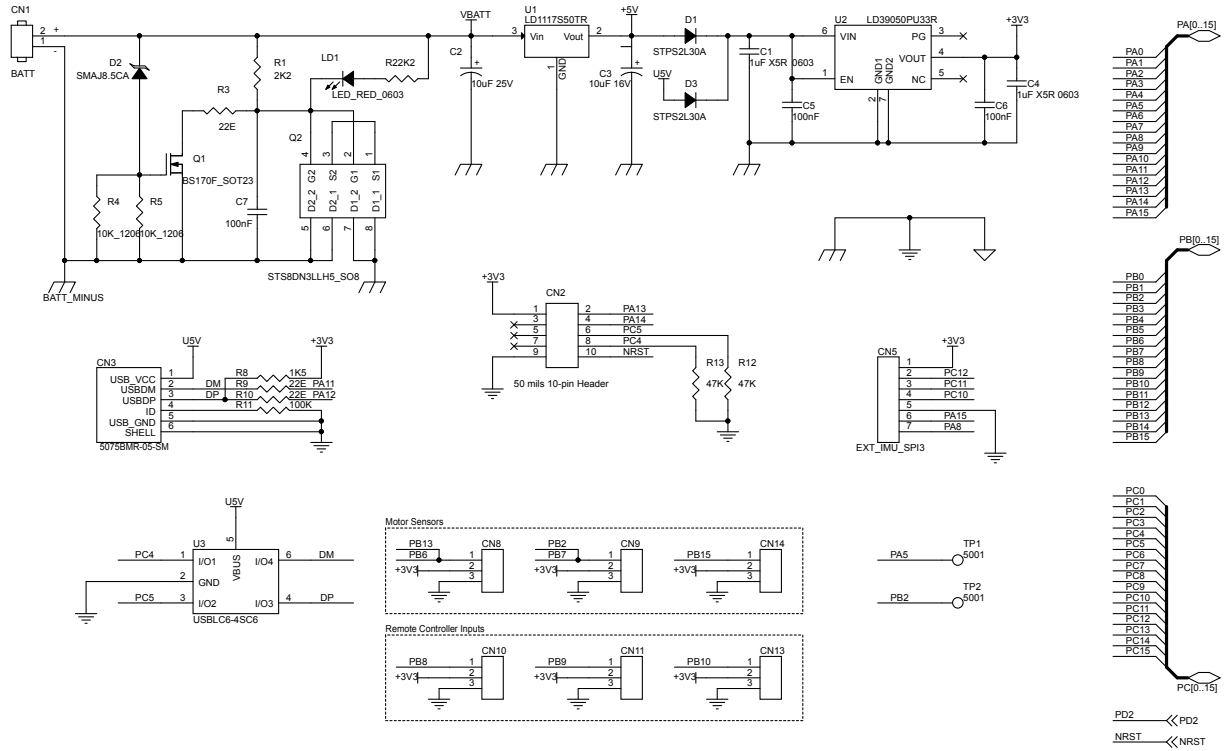
**Figure 1. STEVAL-GMBL01V1 schematic - interfaces**

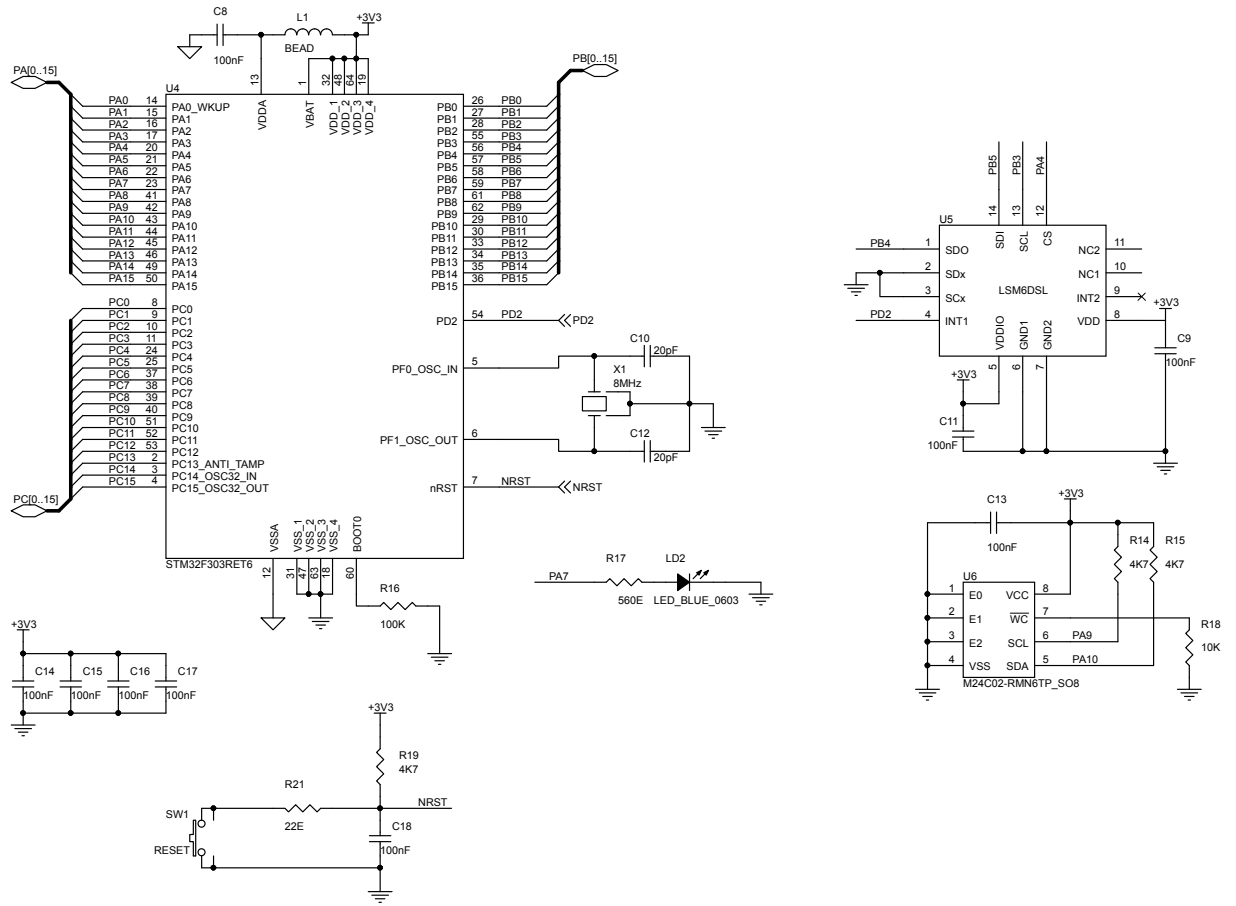
**Figure 2. STEVAL-GMBL01V1 schematic – MCU, IMU sensor, EEPROM**

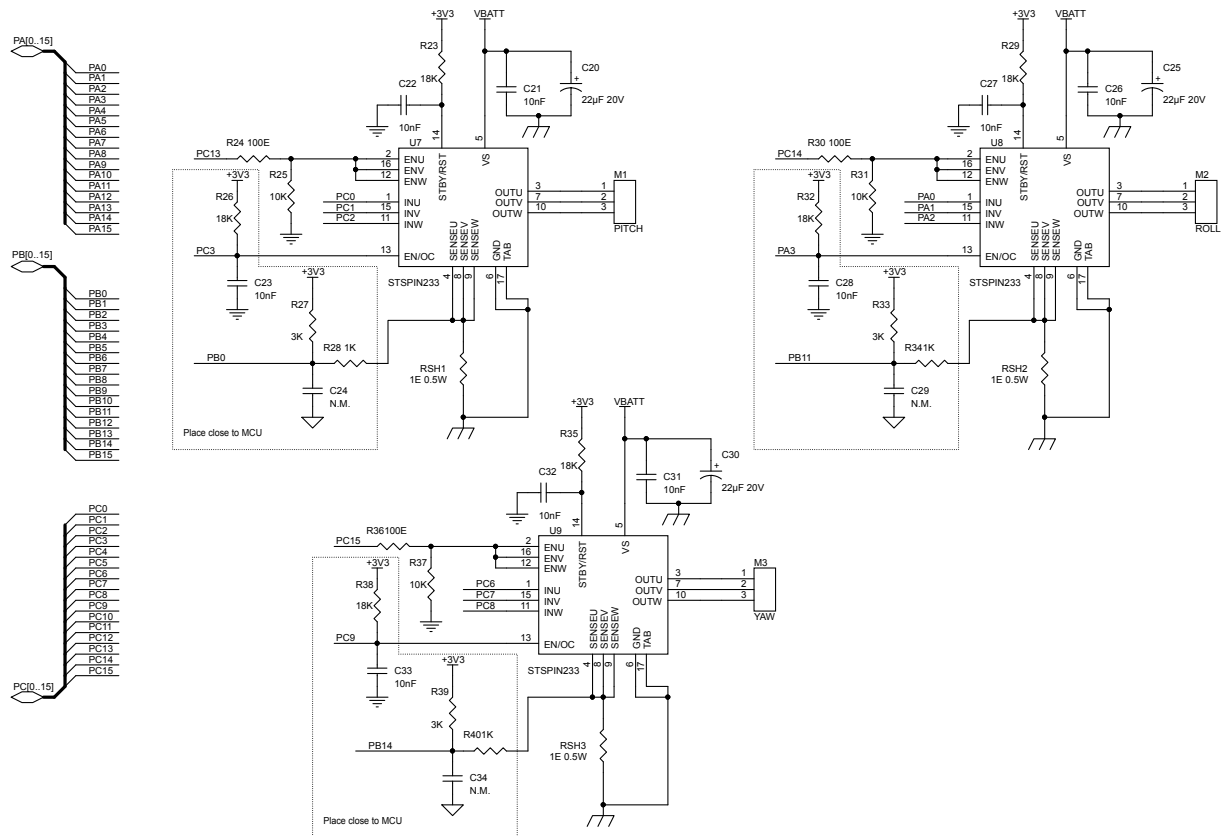
**Figure 3. STEVAL-GMBL01V1 schematic – motor control**

## 1.2 STEVAL-UKI001V1 adapter board schematic diagram

Figure 4. STEVAL-UKI001V1 schematic

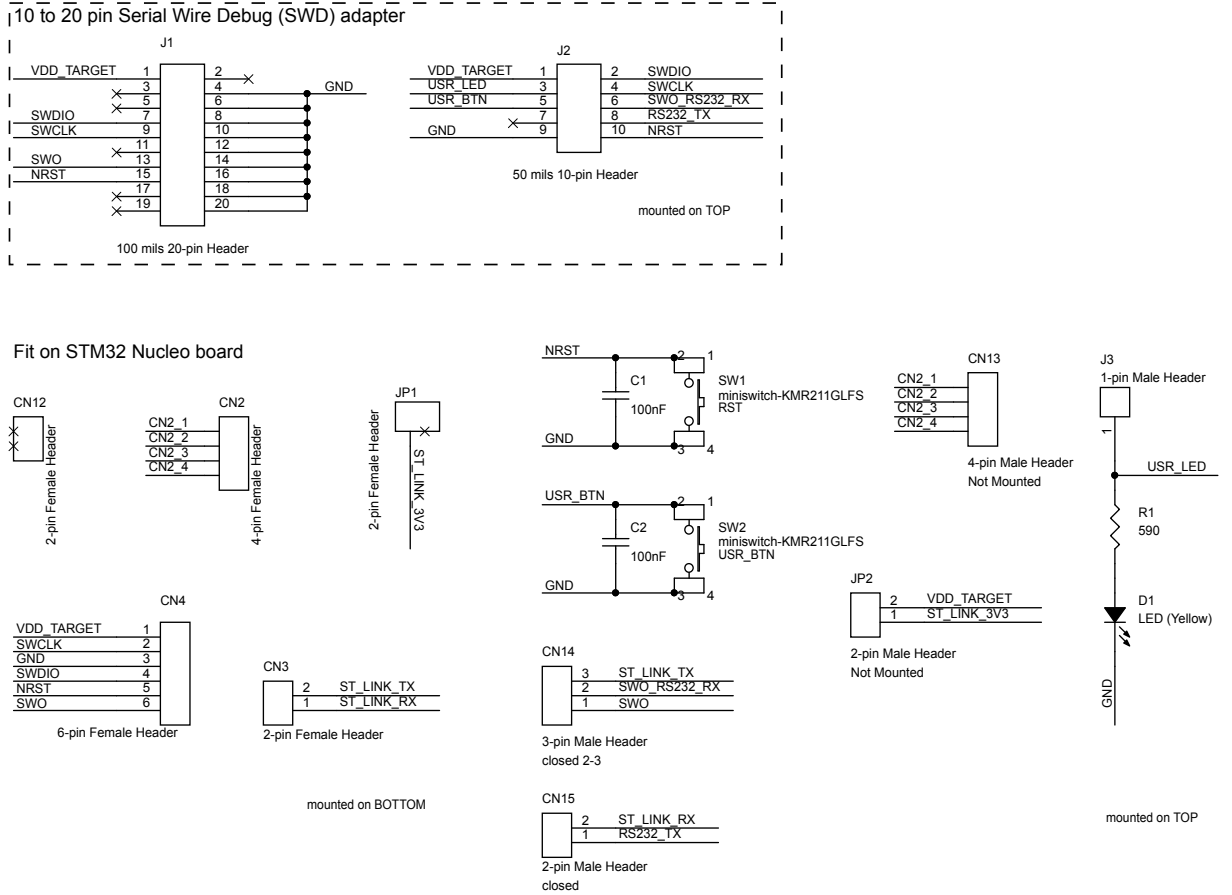

## Revision history

**Table 1. Document revision history**

Date	Version	Changes
20-Aug-2018	1	Initial release.
18-Oct-2018	2	Updated cover image.

**IMPORTANT NOTICE – PLEASE READ CAREFULLY**

STMicroelectronics NV and its subsidiaries (“ST”) reserve the right to make changes, corrections, enhancements, modifications, and improvements to ST products and/or to this document at any time without notice. Purchasers should obtain the latest relevant information on ST products before placing orders. ST products are sold pursuant to ST’s terms and conditions of sale in place at the time of order acknowledgement.

Purchasers are solely responsible for the choice, selection, and use of ST products and ST assumes no liability for application assistance or the design of Purchasers’ products.

No license, express or implied, to any intellectual property right is granted by ST herein.

Resale of ST products with provisions different from the information set forth herein shall void any warranty granted by ST for such product.

ST and the ST logo are trademarks of ST. All other product or service names are the property of their respective owners.

Information in this document supersedes and replaces information previously supplied in any prior versions of this document.

© 2018 STMicroelectronics – All rights reserved