

STEVAL-IPMnM1N motor control power board based on the SLLIMM-nano™ 2nd series

Introduction

The STEVAL-IPMnM1N is a compact motor drive power board based on SLLIMM-nano™ (small low-loss intelligent molded module) 2nd series MOSFET-based (STIPN1M50T-H). It provides an affordable and easy-to-use solution for driving high power motors for a wide range of applications such as power white goods, air conditioning, compressors, power fans and 3-phase inverters for motor drives in general. The IPM itself consists of short-circuit rugged MOSFETs and a wide range of features like undervoltage lockout, smart shutdown, embedded temperature sensor and NTC, and overcurrent protection.

The main characteristics of this evaluation board are small size, minimal BOM and high efficiency. It consists of an interface circuit (BUS and V_{CC} connectors), bootstrap capacitors, snubber capacitor, hardware short-circuit protection, fault event and temperature monitoring. In order to increase the flexibility, it is designed to work in single- or three-shunt configuration and with triple current sensing options: three dedicated onboard op-amps, an internal IPM op-amp and op-amps embedded in the MCU. The Hall/Encoder section completes the circuit.

With these advanced characteristics, the system is designed to achieve fast and accurate current feedback conditioning, satisfying the typical requirements for field-oriented control (FOC).

The STEVAL-IPMnM1N is compatible with ST's STM32-based control board, enabling designers to build a complete platform for motor control.

Figure 1: Motor control board (top view) based on SLLIMM-nano™ 2nd series

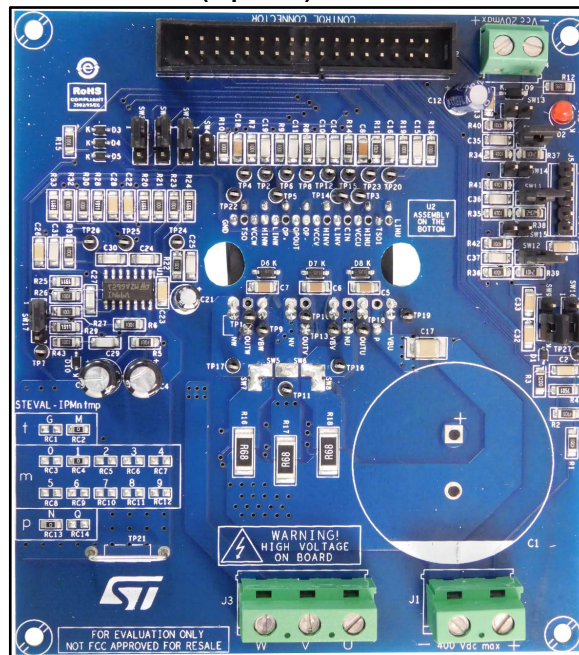

Contents

1	Key features	5
2	Circuit schematics	6
	2.1 Schematic diagrams.....	7
3	Main characteristics	12
4	Filters and key parameters	13
	4.1 Input signals	13
	4.2 Bootstrap capacitor	13
	4.3 Overcurrent protection	14
	4.3.1 SD pin.....	14
	4.3.2 Shunt resistor selection	15
	4.3.3 CIN RC filter	16
	4.3.4 Single- or three-shunt selection.....	16
5	Current sensing amplifying network	17
6	Temperature monitoring	19
	6.1 NTC Thermistor.....	19
7	Firmware configuration for STM32 PMSM FOC SDK	20
8	Connectors, jumpers and test pins	21
9	Bill of materials	24
10	PCB design guide	27
	10.1 Layout of reference board	27
11	Recommendations and suggestions	29
12	General safety instructions	30
13	References	31
14	Revision history	32

List of tables

Table 1: Shunt selection	15
Table 2: Op-amp sensing configuration.....	17
Table 3: Amplifying networks	18
Table 4: ST motor control workbench GUI parameters - STEVAL-IPMnM1N.....	20
Table 5: Connectors.....	21
Table 6: Jumpers	22
Table 7: Test pins	23
Table 8: Bill of materials.....	24
Table 9: Document revision history	32

List of figures

Figure 1: Motor control board (top view) based on SLLIMM-nano™ 2nd series.....	1
Figure 2: Motor control board (bottom view) based on SLLIMM-nano™ 2nd series.....	5
Figure 3: STEVAL-IPMnM1N circuit schematic (1 of 5)	7
Figure 4: STEVAL-IPMnM1N circuit schematic (2 of 5)	8
Figure 5: STEVAL-IPMnM1N circuit schematic (3 of 5)	9
Figure 6: STEVAL-IPMnM1N circuit schematic (4 of 5)	10
Figure 7: STEVAL-IPMnM1N circuit schematic (5 of 5)	11
Figure 8: STEVAL-IPMnM1N architecture.....	12
Figure 9: CBOOT graph selection	14
Figure 10: One-shunt configuration	16
Figure 11: Three-shunt configuration.....	16
Figure 12: NTC voltage vs temperature.....	19
Figure 13: Silk screen and etch - top side	27
Figure 14: Silk screen and etch - bottom side	28

1 Key features

- Input voltage: 125 - 400 V_{DC}
- Nominal power: up to 60 W
- Nominal current: up to 0.6 A_{rms}
- Input auxiliary voltage: up to 20 V_{DC}
- Motor control connector (32 pins) interfacing with ST MCU boards
- Single- or three-shunt resistors for current sensing (with sensing network)
- Three options for current sensing: external dedicated op-amps, internal SLLIMM-nano op-amp (single) or through MCU
- Overcurrent hardware protection
- IPM temperature monitoring and protection
- Hall sensors (3.3 / 5 V)/encoder inputs (3.3 / 5 V)
- IGBT intelligent power module:
 - SLLIMM-nano™ 2nd series SLLIMM-nano IPM MOSFET-based (STIPN1M50T-H - Full molded package package)
- Universal design for further evaluation with bread board and testing pins
- Very compact size

Figure 2: Motor control board (bottom view) based on SLLIMM-nano™ 2nd series

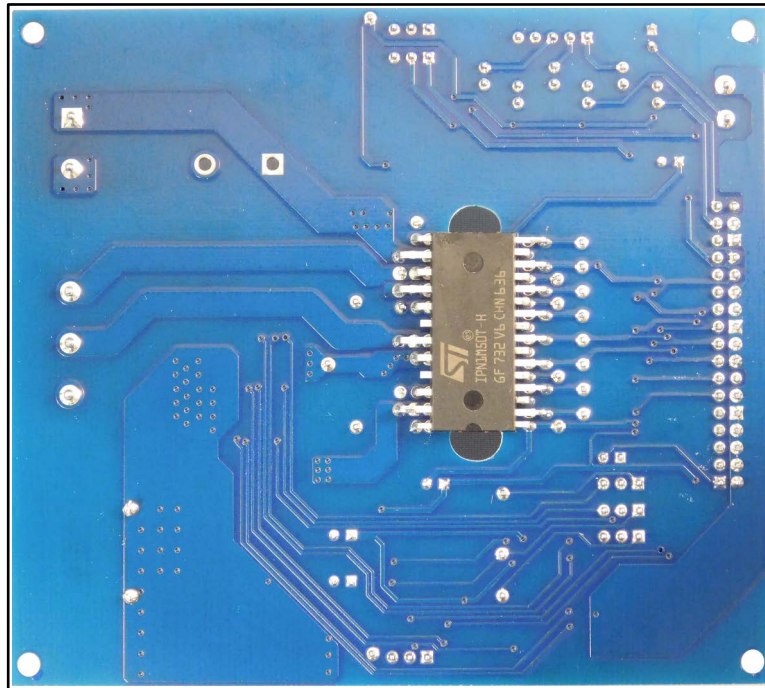

2 Circuit schematics

The full schematics for the SLLIMM-nano™ 2nd series card for STIPN1M50T-H IPM products is shown below. This card consists of an interface circuit (BUS and V_{CC} connectors), bootstrap capacitors, snubber capacitor, short-circuit protection, fault output circuit, temperature monitoring, single-/three-shunt resistors and filters for input signals. It also includes bypass capacitors for V_{CC} and bootstrap capacitors. The capacitors are located very close to the drive IC to avoid malfunction due to noise.

Three current sensing options are provided: three dedicated onboard op-amps, one internal IPM op-amp and the embedded MCU op-amps; selection is performed through three jumpers.

The Hall/Encoder section (powered at 5 V or 3.3 V) completes the circuit.

2.1 Schematic diagrams

Figure 3: STEVAL-IPMnM1N circuit schematic (1 of 5)

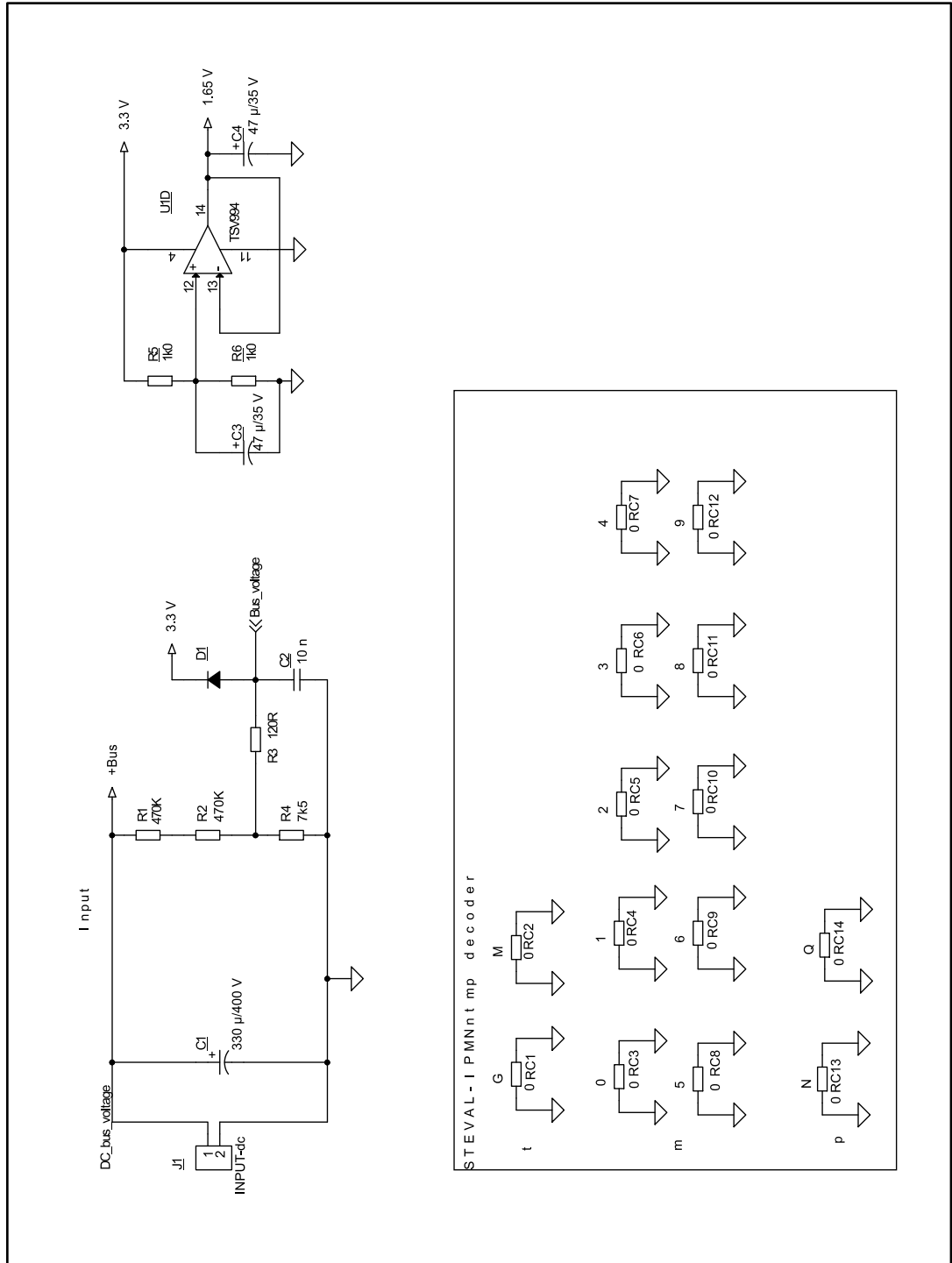

Figure 4: STEVAL-IPMnM1N circuit schematic (2 of 5)

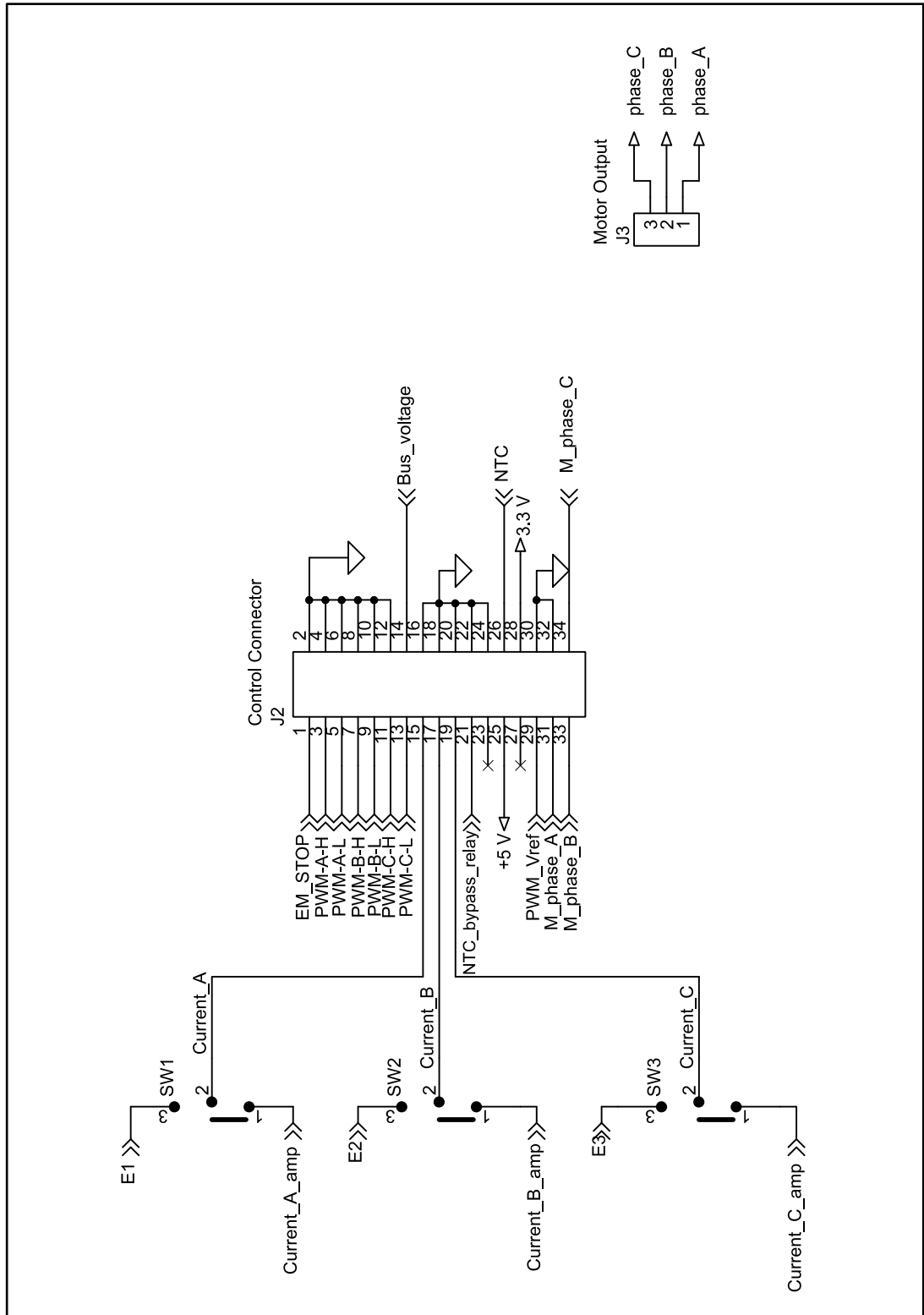

Figure 5: STEVAL-IPMnM1N circuit schematic (3 of 5)

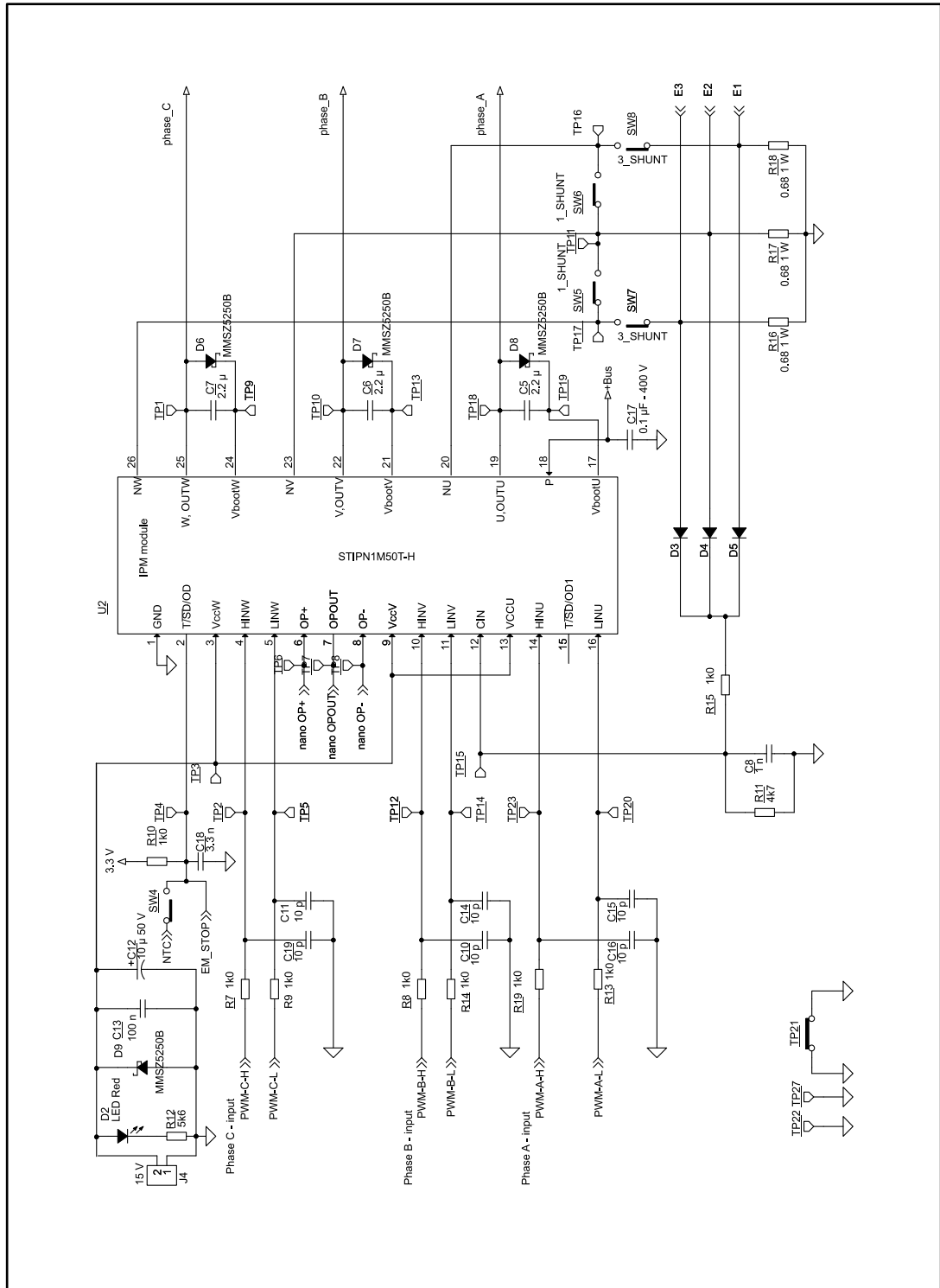
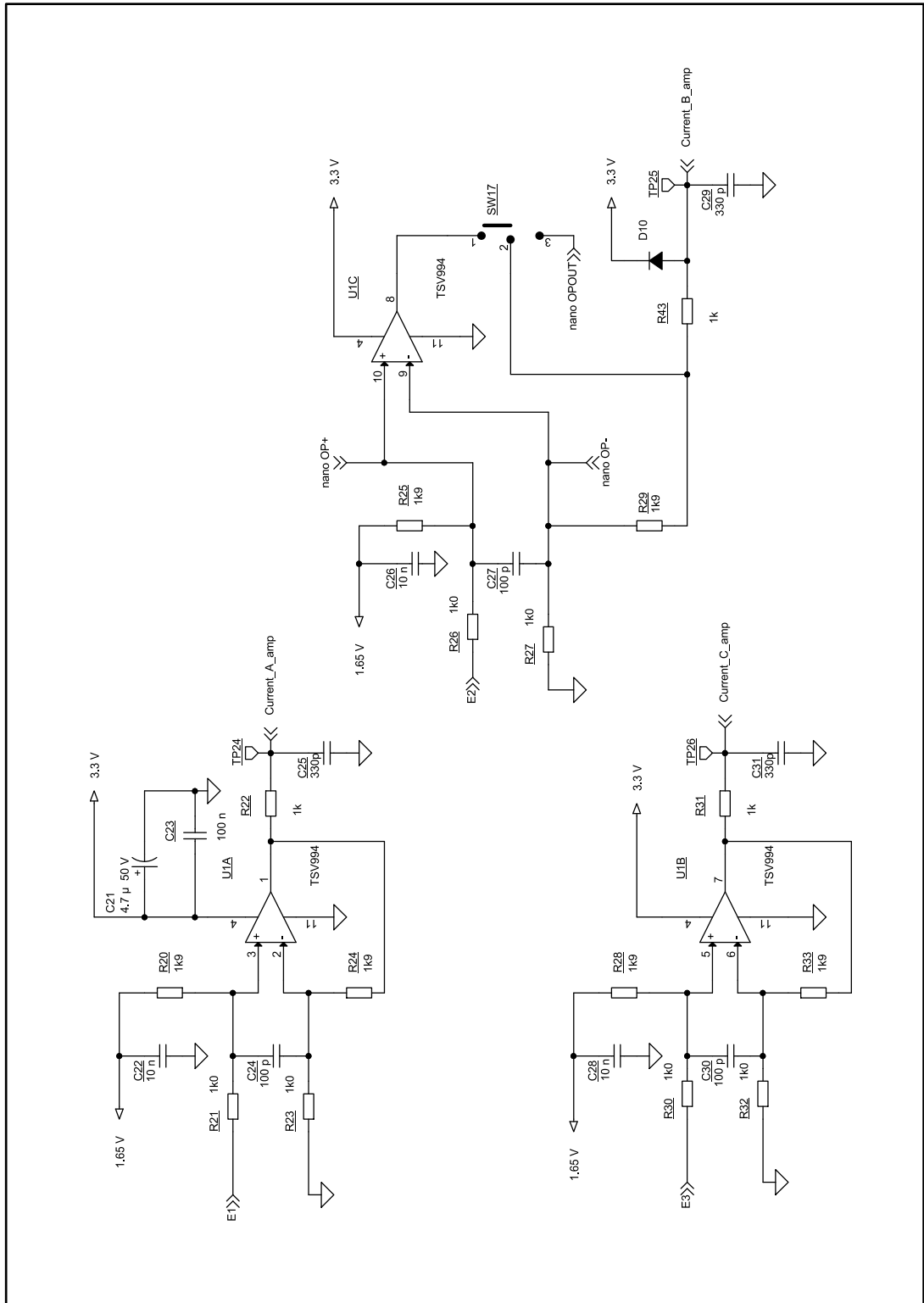

Figure 6: STEVAL-IPMnM1N circuit schematic (4 of 5)



3 Main characteristics

The board is designed for a 125 V_{DC} to 400 V_{DC} supply voltage.

An appropriate bulk capacitor for the power level of the application must be mounted at the dedicated position on the board.

The SLLIMM-nano integrates six IGBT switches with freewheeling diodes and high voltage gate drivers. Thanks to this integrated module, the system offers power inversion in a simple and compact design that requires less PCB area and increases reliability.

The board offers the added flexibility of being able to operate in single- or three-shunt configuration by modifying solder bridge jumper settings (see [Section 4.3.4: "Single- or three-shunt selection"](#)).

Figure 8: STEVAL-IPMnM1N architecture

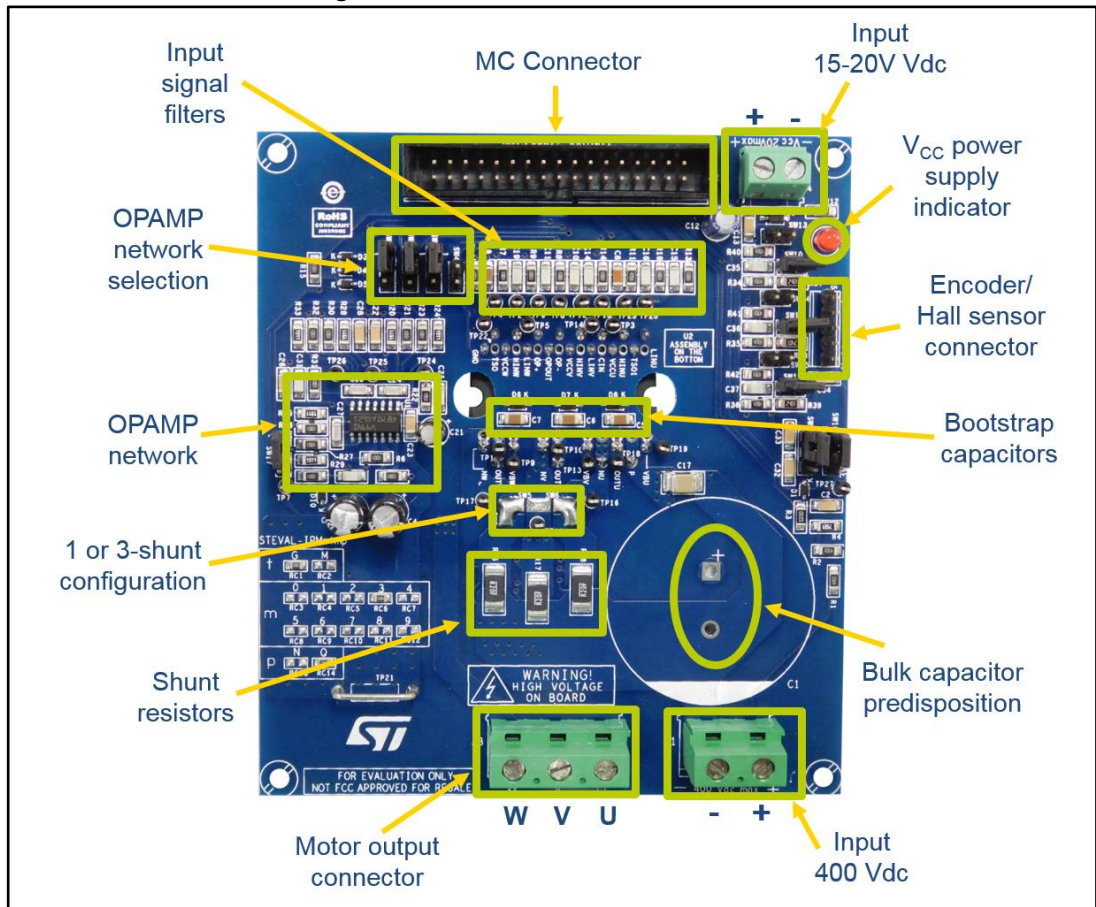

4 Filters and key parameters

4.1 Input signals

The input signals (LINx and HINx) to drive the internal IGBTs are active high. A 375 k Ω (typ.) pull-down resistor is built-in for each input signal. To prevent input signal oscillation, an RC filter is added on each input as close as possible to the IPM. The filter is designed using a time constant of 10 ns (1 k Ω and 10 pF).

4.2 Bootstrap capacitor

In the 3-phase inverter, the emitters of the low side IGBTs are connected to the negative DC bus (V_{DC-}) as common reference ground, which allows all low side gate drivers to share the same power supply, while the emitter of the high side IGBTs is alternately connected to the positive (V_{DC+}) and negative (V_{DC-}) DC bus during running conditions.

A bootstrap method is a simple and cheap solution to supply the high voltage section. This function is normally accomplished by a high voltage fast recovery diode. The SLLIMM-nano 2nd series family includes a patented integrated structure that replaces the external diode with a high voltage DMOS functioning as a diode with series resistor. An internal charge pump provides the DMOS driving voltage.

The value of the C_{BOOT} capacitor should be calculated according to the application requirements.

Figure 9: "CBOOT graph selection" shows the behavior of C_{BOOT} (calculated) versus switching frequency (f_{sw}), with different values of ΔV_{CBOOT} for a continuous sinusoidal modulation and a duty cycle $\delta = 50\%$.



This curve is taken from application note AN4840 (available on www.st.com); calculations are based on the STGIP5C60T-Hyy device, which represents the worst case scenario for this kind of calculation.

The boot capacitor must be two or three times larger than the C_{BOOT} calculated in the graph.

For this design, a value of 2.2 μF was selected.

Figure 9: CBOOT graph selection

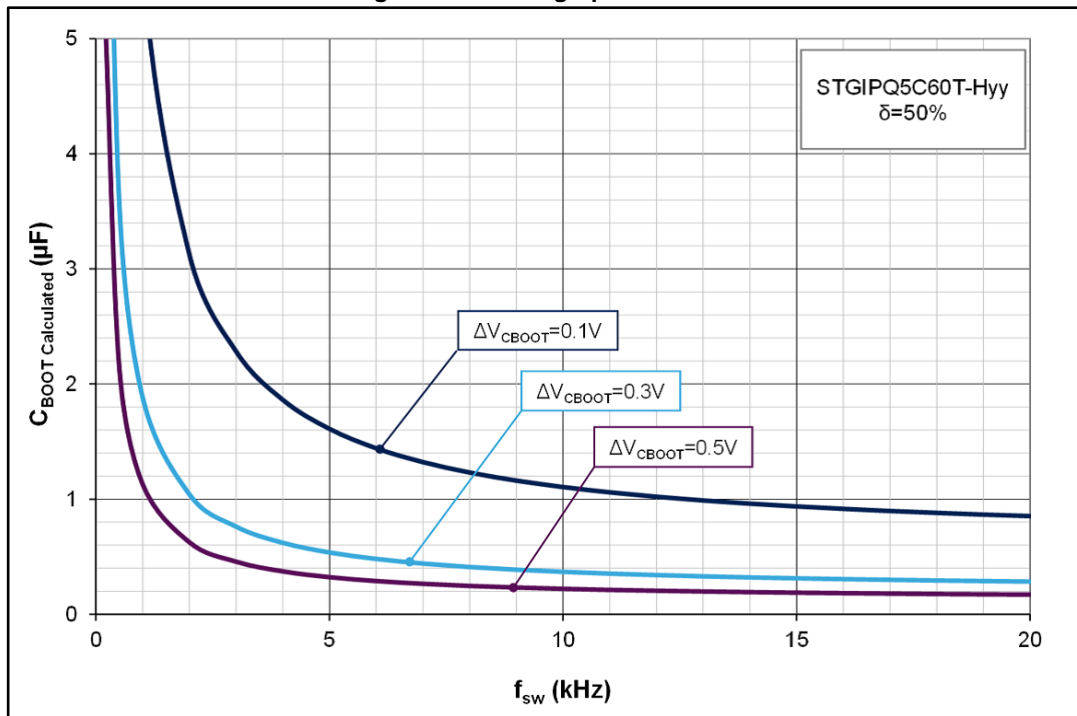

4.3 Overcurrent protection

The SLLIMM-nano 2nd series integrates a comparator for fault sensing purposes. The comparator has an internal voltage reference V_{REF} (540 mV typ.) connected to the inverting input, while the non-inverting input on the CIN pin can be connected to an external shunt resistor to implement the overcurrent protection function. When the comparator triggers, the device enters the shutdown state.

The comparator output is connected to the \overline{SD} pin in order to send the fault message to the MCU.

4.3.1 SD pin

The \overline{SD} is an input/output pin (open drain type if used as output) used for enable and fault; it is shared with NTC thermistor, internally connected to GND.

The pull-up resistor (R10) causes the voltage V_{SD-GND} to decrease as the temperature increases. To maintain the voltage above the high-level logic threshold, the pull-up resistor is sized at 1 kΩ (3.3 V MCU power supply).

The filter on \overline{SD} (R10 and C18) must be sized to obtain the desired re-starting time after a fault event and placed as close as possible to the pin.

A shutdown event can be managed by the MCU; in which case, the SD functions as the input pin.

Conversely, the SD functions as an output pin when an overcurrent or undervoltage condition is detected.

4.3.2 Shunt resistor selection

The value of the shunt resistor is calculated by the following equation:

Equation 1

$$R_{SH} = \frac{V_{ref}}{I_{OC}}$$

Where V_{ref} is the internal comparator (CIN) (0.54 V typ.) and I_{OC} is the overcurrent threshold detection level.

The maximum OC protection level should be set to less than the pulsed collector current in the datasheet. In this design, the overcurrent threshold level is fixed at $I_{OC} = 1.3$ A in order to select a commercial shunt resistor value.

Equation 2

$$R_{SH} = \frac{V_{ref} \cdot \left(\frac{R15 + R11}{R11} \right) + V_F}{I_{OC}} = \frac{0.54 \cdot \left(\frac{1000 + 4700}{4700} \right) + 0.18}{1.3} = 0.642 \Omega$$

Where V_F is the voltage drop across diodes D3, D4 and D5.

For the power rating of the shunt resistor, the following parameters must be considered:

- Maximum load current of inverter (85% of $I_{nom [Arms]}$): $I_{load(max)}$.
- Shunt resistor value at $T_C = 25$ °C.
- Power derating ratio of shunt resistor at $T_{SH} = 100$ °C
- Safety margin.

The power rating is calculated by the following equation:

Equation 3

$$P_{SH} = \frac{1}{2} \cdot \frac{I_{load(max)}^2 \cdot R_{SH} \cdot margin}{Deratin\ ratio}$$

The commercial value chosen was 0.66 Ω to which corresponds an overcurrent level of 1.3 A.

The power rating is:

- $I_{nom} = 1$ A $\rightarrow I_{nom[rms]} = \frac{I_{nom}}{\sqrt{2}} \rightarrow I_{load(max)} = 85\% (I_{nom[rms]}) = 0.6$ A_{rms}
- Power derating ratio of shunt resistor at $T_{SH} = 100$ °C: 80% (from datasheet manufacturer)
- Safety margin: 30%

Equation 4

$$P_{SH} = \frac{1}{2} \cdot \frac{0.6^2 \cdot 0.66 \cdot 1.3}{0.8} = 0.19$$
 W

Considering the commercial value, a 1 W shunt resistor was selected.

Based on the previous equations and conditions, the minimum shunt resistance and power rating is summarized below.

Table 1: Shunt selection

Device	$I_{nom (peak)}$ [A]	OCP _(peak) [A]	$I_{load(max)}$ [Arms]	R _{SHUNT} [Ω]	Minimum shunt power rating P _{SH} [W]
STIPN1M50T-H	1	1.3	0.6	0.68	0.19

4.3.3 CIN RC filter

An RC filter network on the CIN pin is required to prevent short-circuits due to the noise on the shunt resistor. In this design, the R15-C8 RC filter has a constant time of about 1 μ s.

4.3.4 Single- or three-shunt selection

Single- or three-shunt resistor circuits can be adopted by setting the solder bridges SW5, SW6, SW7 and SW8.

The figures below illustrate how to set up the two configurations.

Figure 10: One-shunt configuration



Figure 11: Three-shunt configuration

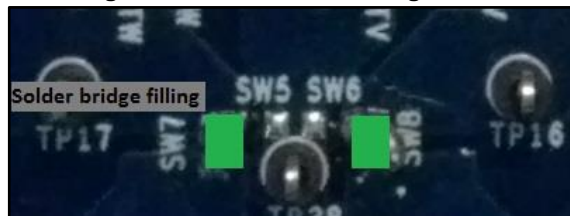

Further details regarding sensing configuration are provided in the next section.

5 Current sensing amplifying network

The STEVAL-IPMnM1N motor control evaluation board can be configured to run in three-shunt or single-shunt configurations for field oriented control (FOC).

The current can be sensed thanks to the shunt resistor and amplified by using the on-board operational amplifiers or by the MCU (if equipped with op-amp).

Once the shunt configuration is chosen by setting solder bridge on SW5, SW6, SW7 and SW8 (as described in [Section 4.3.4: "Single- or three-shunt selection"](#)), the user can choose whether to send the voltage shunt to the MCU amplified or not amplified.

Single-shunt configuration requires a single op amp so the only voltage sent to the MCU to control the sensing is connected to phase V through SW2.

Switch SW17 is used to send amplified signal coming from the internal IPM op-amp or from an external one.

SW1, SW2, SW3 and SW17 can be configured to select which signals are sent to the microcontroller, as per the following table.

Table 2: Op-amp sensing configuration

Configuration	Sensing	Bridge (SW1)	Bridge (SW2)	Bridge (SW3)	Bridge (SW17)
Single Shunt	IPM op-amp	open	1-2	open	2-3
	On board op-amp	open	1-2	open	1-2
	MCU op-amp	open	2-3	open	1-2
Three Shunt	On board op-amp	1-2	1-2	1-2	1-2
	MCU op-amp	2-3	2-3	2-3	1-2

The operational amplifier TSV994 used on the amplifying networks has a 20 MHz gain bandwidth from a single positive supply of 3.3 V.

The amplification network must allow bidirectional current sensing, so an output offset $V_o = +1.65$ V represents zero current.

For the STIPN1M50T-H ($I_{OCP} = 1.3$ A; $R_{SHUNT} = 0.68$ Ω), the maximum measurable phase current, considering that the output swings from +1.65 V to +3.3 V (MCU supply voltage) for positive currents and from +1.65 V to 0 for negative currents is:

Equation 5

$$MaxMeasCurrent = \frac{\Delta V}{r_m} = 1.3 \text{ A}$$

$$r_m = \frac{\Delta V}{MaxMeasCurrent} = \frac{1.65}{1.3} = 1.27 \Omega$$

The overall trans-resistance of the two-port network is:

$$r_m = R_{SHUNT} \cdot AMP = 0.66 \cdot AMP = 1.27 \Omega$$

$$AMP = \frac{r_m}{R_{SHUNT}} = \frac{1.27}{0.66} = 1.9$$

Finally choosing $R_a=R_b$ and $R_c=R_d$, the differential gain of the circuit is:

$$AMP = \frac{R_c}{R_a} = 1.9$$

An amplification gain of 1.9 was chosen. The same amplification is obtained for all the other devices, taking into account the OCP current and the shunt resistance, as described in [Table 1: "Shunt selection"](#).

The RC filter for output amplification is designed to have a time constant that matches noise parameters in the range of 1.5 μs :

$$4 \cdot \tau = 4 \cdot R_e \cdot C_c = 1.5 \mu s$$

$$C_c = \frac{1.5 \mu s}{4 \cdot 1000} = 375 \text{ pF} (330 \text{ pF selected})$$

Table 3: Amplifying networks

Phase	Amplifying network				RC filter	
	Ra	Rb	Rc	Rd	Re	Cc
Phase U	R21	R23	R20	R24	R22	C25
Phase V	R26	R27	R25	R29	R43	C29
Phase W	R30	R32	R28	R33	R31	C31

6 Temperature monitoring

The SLLIMM-nano 2nd series family integrates an NTC thermistor placed close to the power stage. The board is designed to use it in sharing with the \overline{SD} pin. Monitoring can be enabled and disabled via the SW4 switch.

6.1 NTC Thermistor

The built-in thermistor (85 k Ω at 25 °C) is inside the IPM and connected on \overline{SD} /OD pin2 (shared with the SD function).

Given the NTC characteristic and the sharing with the \overline{SD} function, the network is designed to keep the voltage on this pin higher than the minimum voltage required for the pull up voltage on this pin over the whole temperature range.

Considering $V_{bias} = 3.3 V$, a pull up resistor of 1 k Ω (R10) was used.

The figure below shows the typical voltage on this pin as a function of device temperature.

Figure 12: NTC voltage vs temperature

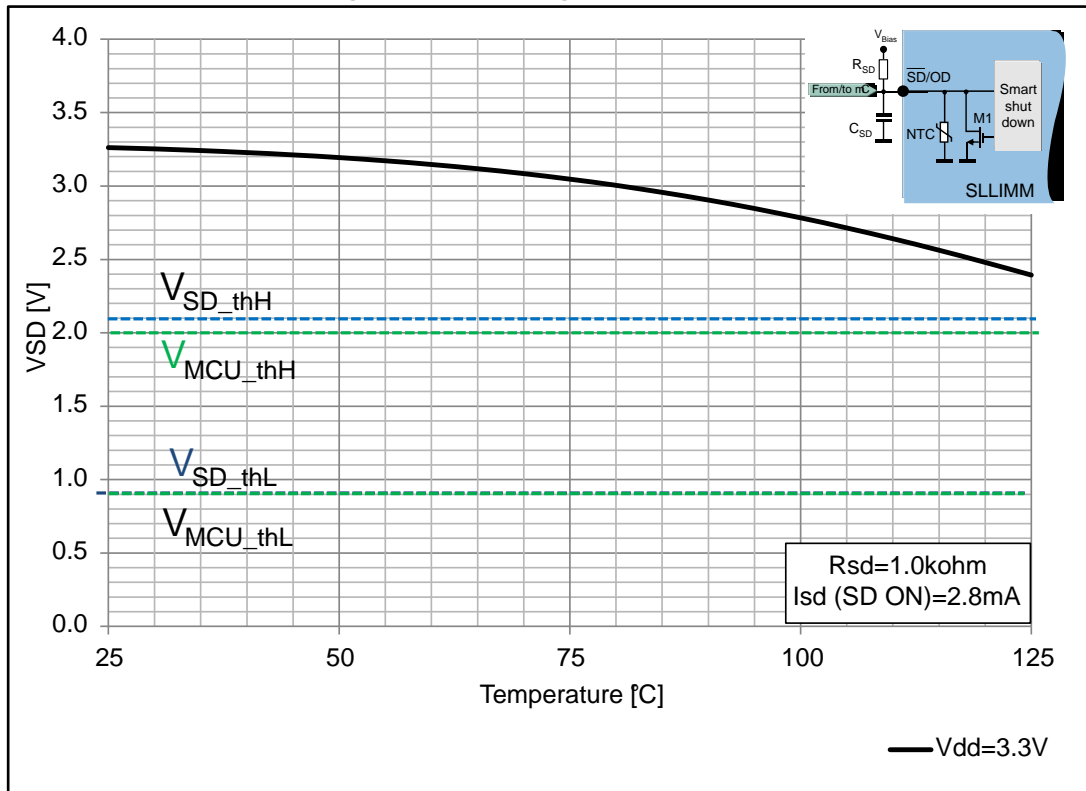

7 Firmware configuration for STM32 PMSM FOC SDK

The following table summarizes the parameters which customize the latest version of the ST FW motor control library for permanent magnet synchronous motors (PMSM): STM32 PMSM FOC SDK for this STEVAL-IPMnM1N.

Table 4: ST motor control workbench GUI parameters - STEVAL-IPMnM1N

Block	Parameter	Value
Over current protection	Comparator threshold	$V_{ref} \cdot \left(\frac{R15 + R11}{R11} \right) + V_F = 0.83 V$
	Overcurrent network offset	0
	Overcurrent network gain	0.1 V/A
Bus voltage sensing	Bus voltage divider	1/125
Rated bus voltage info	Min rated voltage	125 V
	Max rated voltage	400 V
	Nominal voltage	325 V
Current sensing	Current reading typology	Single- or three-shunt
	Shunt resistor value	0.68 Ω
	Amplifying network gain	1.9
Command stage	Phase U Driver	HS and LS: Active high
	Phase V Driver	HS and LS: Active high
	Phase W Driver	HS and LS: Active high

8 Connectors, jumpers and test pins

Table 5: Connectors

Connector	Description / pinout	
J1	Supply connector (DC – 125 V to 400 V) <ul style="list-style-type: none"> 1-L - phase 2 N - neutral 	
J2	Motor control connector	
	1 - emergency stop 3 - PWM-1H 5 - PWM-1L 7 - PWM-2H 9 - PWM-2L 11 - PWM-3H 13 - PWM-3L 15 - current phase A 17 - current phase B 19 - current phase C 21 - NTC bypass relay 23 - dissipative brake PWM 25 - +V power 27- PFC sync. 29 - PWM VREF 31 - measure phase A 33 - measure phase B	2 - GND 4 - GND 6 - GND 8 - GND 10 - GND 12 - GND 14 - HV bus voltage 16 - GND 18 - GND 20 - GND 22 - GND 24 - GND 26 - heat sink temperature 28 - VDD_m 30 - GND 32 - GND 34 - measure phase C
J3	Motor connector <ul style="list-style-type: none"> phase A phase B phase C 	
J4	V _{CC} supply (20 V _{DC} max) <ul style="list-style-type: none"> positive negative 	
J5	Hall sensors / encoder input connector <ol style="list-style-type: none"> Hall sensors input 1 / encoder A+ Hall sensors input 2 / encoder B+ Hall sensors input 3 / encoder Z+ 3.3 or 5 Vdc GND 	

Table 6: Jumpers

Jumper	Description	
SW1	To choose current U to send to control board:	
	Jumper on 1-2: from amplification	
	Jumper on 2-3: directly from motor output	
SW2	To choose current V to send to control board	
	Jumper on 1-2: from amplification	
	Jumper on 2-3: directly from motor output	
SW3	To choose current W to send to control board:	
	Jumper on 1-2: from amplification	
	Jumper on 2-3: directly from motor output	
SW4	To send or not temperature information, coming from NTC, to micro	
SW5, SW6 SW7, SW8	To choose one shunt or 3 shunt configuration. (Through solder bridge)	
	SW5, SW6 close SW7, SW8 open	one shunt
	SW5, SW6 open SW7, SW8 close	three shunt
SW9, SW16	To choose input power for Hall/Encoder	
	Jumper on 1-2: 5 V	
	Jumper on 2-3: 3.3 V	
SW10, SW13	To modify phase A hall sensor network	
SW11, SW14	To modify phase B hall sensor network	
SW12, SW15	To modify phase C hall sensor network	
SW17	To choose on board or IPM op-amp in one shunt configuration	
	Jumper on 1-2: on board op-amp	
	Jumper on 2-3: IPM op-amp	

Table 7: Test pins

Test Pin	Description
TP1	OUTW
TP2	HINW (high side W control signal input)
TP3	VccW
TP4	\overline{SD} (shutdown pin)/NTC
TP5	LINW (high side W control signal input)
TP6	OP+
TP7	OPOUT
TP8	OP-
TP9	VbootW
TP10	OUTV
TP11	NV
TP12	HINV (high side V control signal input)
TP13	VbootV
TP14	LINV (high side V control signal input)
TP15	CIN
TP16	NU
TP17	NW
TP18	OUTU
TP19	VbootU
TP20	LINU (high side U control signal input)
TP21	Ground
TP22	Ground
TP23	HinU (high side U control signal input)
TP24	Current_A_amp
TP25	Current_B_amp
TP26	Current_C_amp
TP27	Ground

9 Bill of materials

Table 8: Bill of materials

Item	Qty	Reference	Part/Value	Description	Manufacturer	Order code
1	0	C1	330 μ F 400 V \pm 10%	Electrolytic capacitor - DNM	EPCOS	B43501A9337M000
2	4	C2, C22, C26, C28	10 nF 50 V \pm 10%	Ceramic multilayer capacitors	AVX	12065C103KAT2A
3	2	C3, C4	47 μ F 50 V \pm 20%	Electrolytic capacitor	any	any
4	3	C5, C6, C7	2.2 μ F 25 V \pm 10%	Ceramic multilayer capacitors	Murata	GCM31MR71E225KA57L
5	1	C8	1 nF 50 V \pm 10%	Ceramic multilayer capacitors	Kemet	C1206C102K5RACTU
6	1	C12	10 μ F 50 V \pm 20%	Electrolytic capacitor	AVX	12061A100JAT2A
7	9	C10, C11, C14, C15, C16, C19, C35, C36, C37	10 pF 100 V \pm 10%	Ceramic multilayer capacitors	AVX	12061A100JAT2A
8	1	C17	0.1 μ F 630 V \pm 10%	Ceramic multilayer capacitor	Murata	GRM43DR72J104KW01L
9	1	C18	3.3 nF 50 V \pm 10%	Ceramic multilayer capacitor	Kemet	C1206C332K5RACTU
10	1	C21	4.7 μ F 50 V \pm 20%	Electrolytic capacitor	any	any
11	3	C24, C27, C30	100 pF 100 V \pm 10%	Ceramic multilayer capacitors	Kemet	C1206C101J1GACTU
12	3	C25, C29, C31	330 pF 50 V \pm 10%	Ceramic multilayer capacitors	AVX	12065A331JAT2A
13	5	C13, C23, C32, C33, C34	100 nF 50 V \pm 10%	Ceramic multilayer capacitors	AVX	12065C104KAZ2A
14	5	D1, D3, D4, D5, D10	Diode BAT48J	-	ST	BAT48J
15	1	D2	LED	Red LED	Ledtech	L4RR3000G1EP4
16	4	D6, D7, D8, D9	20 V \pm 5%	ZENER diode	Fairchild Semiconductor	MMSZ5250B

Item	Qty	Reference	Part/Value	Description	Manufacturer	Order code
17	1	J1	7.62 mm - 2 P 300 V	Connector	TE Connectivity AMP Connectors	282845-2
18	1	J2	34 P	Connector	RS	625-7347
19	1	J3	7,62 mm - 3 P 400 V	Connector	TE Connectivity AMP Connectors	282845-3
20	1	J4	5 mm - 2 P 50 V	Connector	Phoenix Contact	1729128
21	1	J5	2.54 mm - 5 P 63 V	Connector	RS	W81136T3825RC
22	2	R1, R2	470 k Ω 400 V \pm 1%	Metal film SMD resistor	any	any
23	1	R3	120 Ω 400 V \pm 1%	Metal film SMD resistor	any	any
24	1	R4	7.5 k Ω 400 V \pm 1%	Metal film SMD resistor	Panasonic	ERJP08F7501V
25	1 9	R5, R6, R7, R8, R9, R10, R13, R14, R15, R19, R21, R22, R23, R26, R27, R30, R31, R32, R43	1 k Ω 25 V \pm 1%	Metal film SMD resistor	any	any
26	1	R12	5.6 k Ω 25 V \pm 1%	Metal film SMD resistor	any	any
27	3	R16, R17, R18	0.68 Ω \pm 1%	Metal film SMD resistor	Panasonic	ERJ1TRQFR68U
28	6	R20, R24, R25, R28, R29, R33	1.9 k Ω , 25 V \pm 1%	Metal film SMD resistor	any	any
29	3	R37, R38, R39	2.4 k Ω 25 V \pm 1%	Metal film SMD resistor	any	any
30	7	R11, R34, R35, R36, R40, R41, R42	4.7 k Ω 25 V \pm 1%	Metal film SMD resistor	any	any
31	3	RC1, RC8, RC14	0 Ω	Metal film SMD resistor	any	any

Item	Qty	Reference	Part/Value	Description	Manufacturer	Order code
32	0	RC2, RC3, RC4, RC5, RC6, RC7, RC9, RC10, RC11, RC12, RC13	DNM			
33	2	SW7, SW8	Solder Bridge	-	-	-
34	2	SW5, SW6	open	-	-	-
35	6	SW1, SW2, SW3, SW9, SW16, SW17	Jumper 2.54	PTH 3 pin	RS	W81136T3825RC
36	7	SW4, SW10, SW11, SW12, SW13, SW14, SW15	Jumper 2.54	PTH 2 pin	RS	W81136T3825RC
37	26	TP1, TP2, TP3, TP4, TP5, TP6, TP7, TP8, TP9, TP10, TP11, TP12, TP13, TP14, TP15, TP16, TP17, TP18, TP19, TP20, TP22, TP23, TP24, TP25, TP26, TP27	PCB terminal 1 mm	PTH 1 pin	KEYSTONE	5001
38	1	TP21	PCB terminal 12.7 mm		HARWIN	D3083B-46
39	10	to close SWxy	Jumper TE Connectivity female straight, Black, 2-way, 2.54 mm	-	RS	881545-2
40	1	U1	TSV994IDT	-	ST	TSV994IDT
41	1	U2	STIPN1M50T- H	PTH 26 pin	ST	STIPN1M50T-H

Figure 14: Silk screen and etch - bottom side

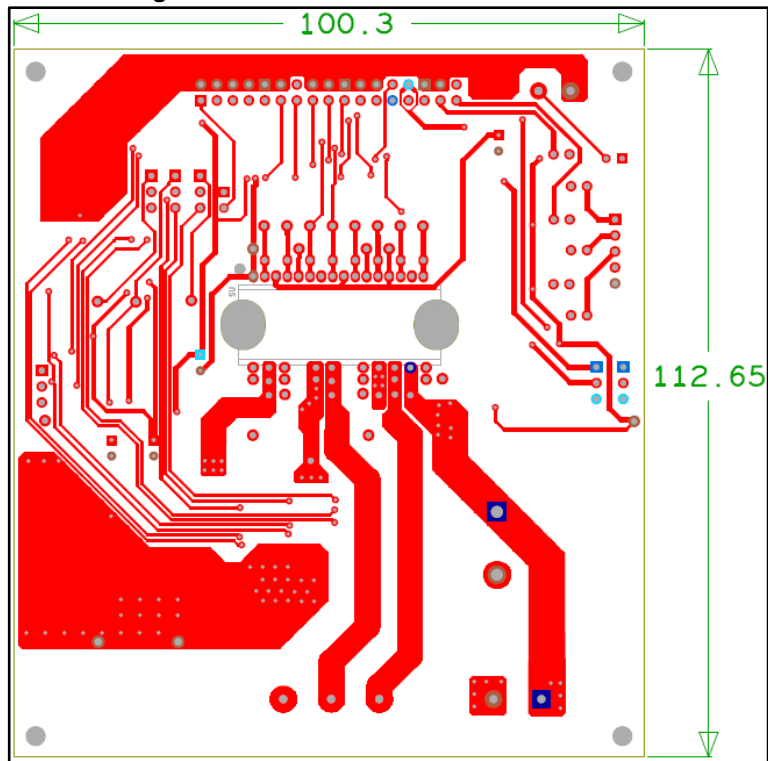

11 Recommendations and suggestions

- The BOM list is not provided with a bulk capacitor already inserted in the PCB. However, the necessary space has been included (C1). In order to obtain a stable bus supply voltage, it is advisable to use an adequate bulk capacity. For general motor control applications, an electrolytic capacitor of at least 100 μF is suggested.
- Similarly, the PCB does not come with a heat sink. You can place one above the IPM on the back side of the PCB with thermal conductive foil and screws. R_{TH} is an important factor for good thermal performance and depends on certain factors such as current phase, switching frequency, power factor and ambient temperature.
- The board requires +5 V and +3.3 V to be supplied externally through the 34-pin motor control connector J2. Please refer to the relevant board manuals for information on key connections and supplies.

12 General safety instructions



The evaluation board works with high voltage which could be deadly for the users. Furthermore all circuits on the board are not isolated from the line input. Due to the high power density, the components on the board as well as the heat sink can be heated to a very high temperature, which can cause a burning risk when touched directly. This board is intended for use by experienced power electronics professionals who understand the precautions that must be taken to ensure that no danger or risk may occur while operating this board.



After the operation of the evaluation board, the bulk capacitor C1 (if used) may still store a high energy for several minutes. So it must be first discharged before any direct touching of the board.



To protect the bulk capacitor C1, we strongly recommended using an external brake chopper after C1 (to discharge the high brake current back from the induction motor).

13 References

Freely available on www.st.com:

1. STIPN1M50T-H datasheet
2. TSV994 datasheet
3. BAT48 datasheet
4. MMSZ5250B datasheet
5. UM1052 *STM32F PMSM single/dual FOC SDK v4.3*
6. AN4840 *SLLIMM™-nano 2nd series small low-loss intelligent molded module*

14 Revision history

Table 9: Document revision history

Date	Version	Changes
12-Sep-2017	1	Initial release.

IMPORTANT NOTICE – PLEASE READ CAREFULLY

STMicroelectronics NV and its subsidiaries ("ST") reserve the right to make changes, corrections, enhancements, modifications, and improvements to ST products and/or to this document at any time without notice. Purchasers should obtain the latest relevant information on ST products before placing orders. ST products are sold pursuant to ST's terms and conditions of sale in place at the time of order acknowledgement.

Purchasers are solely responsible for the choice, selection, and use of ST products and ST assumes no liability for application assistance or the design of Purchasers' products.

No license, express or implied, to any intellectual property right is granted by ST herein.

Resale of ST products with provisions different from the information set forth herein shall void any warranty granted by ST for such product.

ST and the ST logo are trademarks of ST. All other product or service names are the property of their respective owners.

Information in this document supersedes and replaces information previously supplied in any prior versions of this document.

© 2017 STMicroelectronics – All rights reserved