



ON Semiconductor®

<http://onsemi.com>

LA6595T

Monolithic Linear IC

BTL Drive Single-Phase Full-Wave Fan Motor Driver

Overview

The LA6595T is a single-phase bipolar fan motor driver that achieves quiet operation, power savings, silent operation and high efficiency that suppresses reactive current through BTL output linear drive. It provides lock protection and rotation detection circuits on chip, and is optimal for applications that require high reliability and low noise, such as notebook personal computers, power supplies in consumer electronic equipment, car audio, and CPU cooling systems.

Features

- BTL output single-phase full-wave linear drive (gain resistor : 1 to 360kΩ, 51dB)
- Supports low-voltage drive and features a wide usable voltage range (2.2 to 14.0V)
- Low saturation output (high side + low side saturation voltage : V_{Osat} (total) = 1.2V (typical), I_O = 200mA)
- Built-in lock protection and automatic return circuits
- Built-in RD (Rotation Detection) output
- Thermal protection circuit
- Small-sized, high thermal capacity package

Specifications

Maximum Ratings at $T_a = 25^\circ\text{C}$

Parameter	Symbol	Conditions	Ratings	Unit
Supply voltage	V_{CC} max		15	V
Output current	I_{OUT} max		0.5	A
Output voltage	V_{OUT} max		15	V
RD output pin output withstand voltage	V_{RD} max		15	V
RD output current	I_{RD} max		10	mA
Allowable power dissipation	P_d max	Mounted on a specified board*	400	mW
Operating temperature	T_{opr}		-30 to +90	°C
Storage temperature	T_{stg}		-55 to +150	°C

* Specified board : 114.3mm × 76.1mm × 1.6mm, glass epoxy board.

Stresses exceeding Maximum Ratings may damage the device. Maximum Ratings are stress ratings only. Functional operation above the Recommended Operating Conditions is not implied. Extended exposure to stresses above the Recommended Operating Conditions may affect device reliability.

LA6595T

Recommended Operating Conditions at $T_a = 25^\circ\text{C}$

Parameter	Symbol	Conditions	Ratings	Unit
Supply voltage	V_{CC}		2.2 to 14.0	V
Common-phase input voltage range of hall input	V_{ICM}		0 to $V_{CC} - 1.5$	V

Electrical Characteristics at $T_a = 25^\circ\text{C}$, $V_{CC} = 12\text{V}$, Unless otherwise specified.

Parameter	Symbol	Conditions	Ratings			Unit
			min	typ	max	
Circuit current	I_{CC1}	Drive mode (CT = low)	3	6	9	mA
	I_{CC2}	Lock protection mode (CT = high)	2.5	5	7.5	mA
Lock detection capacitor charge current	I_{CT1}		0.9	1.2	1.5	μA
Capacitor discharge current	I_{CT2}		0.10	0.18	0.25	μA
Capacitor charge/discharge current ratio	R_{CT}	$R_{CD} = I_{CT1}/I_{CT2}$	5	6.5	8	
CT charge voltage	V_{CT1}		1.3	1.5	1.7	V
CT discharge voltage	V_{CT2}		0.3	0.5	0.7	V
OUT output low saturation voltage	V_{OL}	$I_O = 200\text{mA}$		0.25	0.45	V
OUT output high saturation voltage	V_{OH}	$I_O = 200\text{mA}$		0.95	1.2	V
Hall input sensitivity	V_{HN}	Zero peak value (including offset and hysteresis)		7	15	mV
RD output pin low-level voltage	V_{RD}	$I_{RD} = 5\text{mA}$		0.15	0.3	V
RD output pin leakage current	$I_{RD L}$	$V_{RD} = 15\text{V}$		1	30	μA

Package Dimensions

unit : mm (typ)

3245B

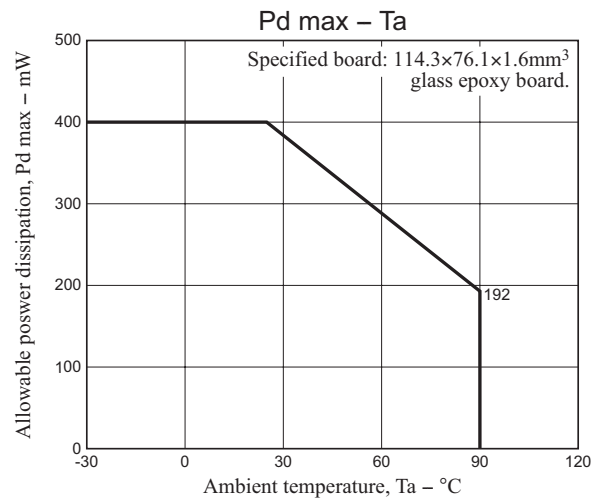
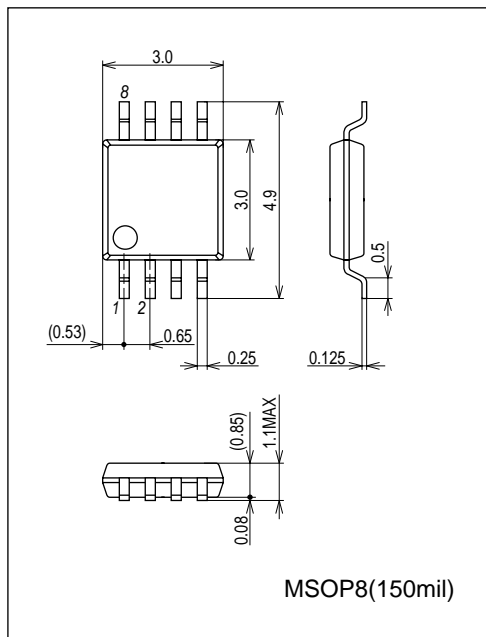

LA6595T

Pin Assignment

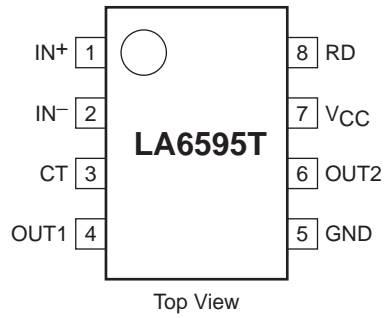

Block Diagram

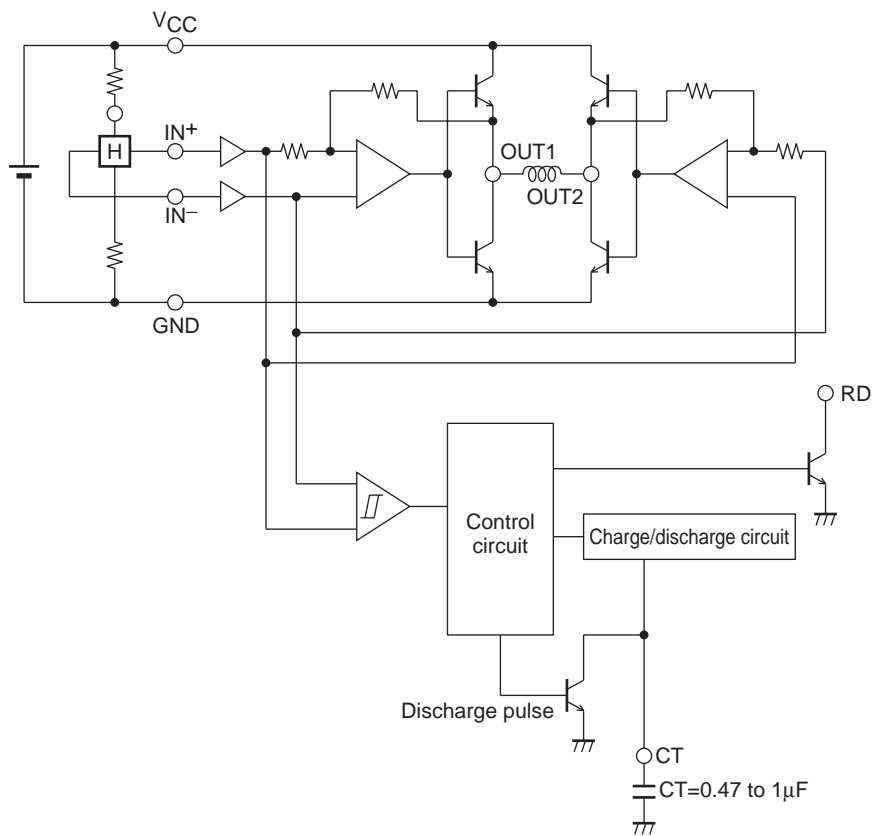

Truth Table

IN ⁻	IN ⁺	CT	OUT1	OUT2	RD	Mode
High	Low	Low	High	Low	Low	During rotation
Low	High		Low	High	Low	
-	-	High	Off	Off	Off	Lock protection

Application Circuit Example

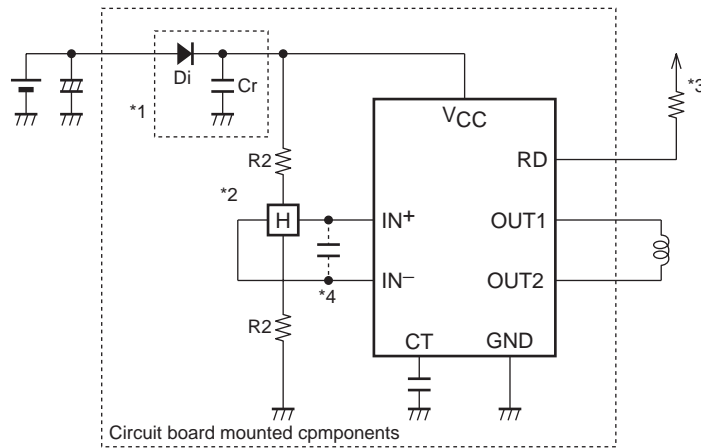

- *1. If the diode Di (which protects the IC destruction by reverse connection) is used, it is necessary to insert the capacitor Cr and provide a regenerative current route. Similarly, if there is no nearby capacitor on the fan power supply line, Cr will also be necessary to improve reliability.
- *2. If the Hall sensor bias is taken from VCC, a 1/2 VCC bias, as shown in the figure, must be used. Linear drive is implemented by amplifying the Hall sensor output and applying voltage control to the coil. If the Hall effect sensor provides a strong output, the startup characteristics and efficiency will be good, then even quieter operation will be achieved by adjusting the Hall effect sensor.
- *3. This pin must be left open if unused.
- *4. If the line from the Hall sensor output to the Hall sensor input of IC are long, noise may enter the system from that line. If that becomes a problem, insert a capacitor as shown in the figure.

ON Semiconductor and the ON logo are registered trademarks of Semiconductor Components Industries, LLC (SCILLC). SCILLC owns the rights to a number of patents, trademarks, copyrights, trade secrets, and other intellectual property. A listing of SCILLC's product/patent coverage may be accessed at www.onsemi.com/site/pdf/Patent-Marking.pdf. SCILLC reserves the right to make changes without further notice to any products herein. SCILLC makes no warranty, representation or guarantee regarding the suitability of its products for any particular purpose, nor does SCILLC assume any liability arising out of the application or use of any product or circuit, and specifically disclaims any and all liability, including without limitation special, consequential or incidental damages. "Typical" parameters which may be provided in SCILLC data sheets and/or specifications can and do vary in different applications and actual performance may vary over time. All operating parameters, including "Typicals" must be validated for each customer application by customer's technical experts. SCILLC does not convey any license under its patent rights nor the rights of others. SCILLC products are not designed, intended, or authorized for use as components in systems intended for surgical implant into the body, or other applications intended to support or sustain life, or for any other application in which the failure of the SCILLC product could create a situation where personal injury or death may occur. Should Buyer purchase or use SCILLC products for any such unintended or unauthorized application, Buyer shall indemnify and hold SCILLC and its officers, employees, subsidiaries, affiliates, and distributors harmless against all claims, costs, damages, and expenses, and reasonable attorney fees arising out of, directly or indirectly, any claim of personal injury or death associated with such unintended or unauthorized use, even if such claim alleges that SCILLC was negligent regarding the design or manufacture of the part. SCILLC is an Equal Opportunity/Affirmative Action Employer. This literature is subject to all applicable copyright laws and is not for resale in any manner.